

SPECIFICATION



OF

LIQUID CRYSTAL DISPLAY MODULE

CUSTOMER : STD

Model No. : UMSH-8253MD-3T

Model version : 0

Document Revision : 3

CUSTOMER APPROVED SIGNATURE			

This specification need to be signed by purchaser or customer as a specification of products production and delivery from MTT. Without signature of this specification , any purchase order for this model no. will be treated and considered that this specification is automatically acknowledged and accepted by purchaser or customer.

Allen Wang
APPROVED

George Tseng
CHECKED

Angus Chiu
CHECKED

Sharon Tsai
PREPARED

Aug-17-2010
Date

COMPANY : No. 2,Fu-hsing Road,Taichung Economic Processing Zone,Tantzu,Taichung,Taiwan,R.O.C.

TEL: 886-4-25314277

FAX: 886-4-25313067



UNITED RADIANT TECHNOLOGY CORP .

Headquarter office: NO.2 FU-SHING ROAD, T.E.P.Z. TANTZU, TAICHUNG, TAIWAN, R.O.C.
TEL: +886-4-25314277 FAX: +886-4-25313067
Factory: NO.12 CHIEN KUO ROAD, T.E.P.Z., TANTZU, TAICHUNG, TAIWAN, R.O.C.

To Whom It May Concern:

In continuing to develop and promote the strategic partnership between United Radiant Technology (URT) and Microtips USA (MTUSA), URT is please to announce that we have entered into an agreement with MTUSA to support some key projects only through MTUSA and as such the attached spec with URT Part no. will be manufactured by URT but support and logistic of the sales will be handled by MTUSA.

URT is confident that this arrangement between our two companies will ultimately benefit the end customer.

Thank You.

Raymond Chen

A handwritten signature in cursive script that reads "Raymond Chen". The signature is written in black ink and is positioned above a horizontal line.

Sales Manager: URT

Revision record

Document Revision	Model No. Version No.	Description	Revision by
0	UMSH-8253MD-T (UFSH-K093EY-FT) Version No. 0	4.3" TFT.	Ring Hsu Zi Xin Ou 23-Jan-2009
1	UMSH-8253MD-1T (UFSH-K093EY-FT) Version No. 0	Remove the touch panel.	Ring Hsu Zi Xin Ou 22-Jan-2009
2	UMSH-8253MD-2T (UFSH-K093EY-1FT) Version No. 0	1. Add Micro Reflective film on LCD. 2. Modify the module number from UMSH-8253MD-1T to UMSH-8253MD-2T.	Ring Hsu Zi Xin Ou 30-Apr-2009
3	UMSH-8253MD-3T (UFSH-K093EY-FT) Version No. 0	1. Add the capacitive touch panel. 2. Modify the module number from UMSH-8253MD-1T to UMSH-8253MD-3T.	Ring Hsu Zi Xin Ou 17-Aug-2010
Revision 3 ; UMSH-8253MD-3T Ver. 0 ; August-17-2010			Page: 2

CONTENTS:

No.	Item	Page
1	BASIC SPECIFICATION 1.1 Mechanical Specification 1.2 Display Specification 1.3 Outline Dimension 1.4 Block Diagram 1.5 Interface Pin	4 4 5 6 7
2	ELECTRICAL CHARACTERISTICS 2.1 Absolute Maximum Ratings 2.2 DC Characteristics 2.2.1 Back-light Characteristics 2.3 AC Characteristics 2.4 Capacitive touch panel controller Timing Specifications 2.5 Capacitive touch panel controller I2C host interface protocol 2.6 Capacitive touch panel controller Report page registers 2.7 Touch Panel Specifications	8 9 9 10~12 12~13 14~15 16~22 23
3	OPTICAL CHARACTERISTICS 3.1 Condition 3.2 Definition of Optical Characteristics	24 25~26
4	RELIABILITY	27
5	PRODUCT HANDING AND APPLICATION	28
6	DATECODE	29
7	PACKING & LOTNO	30~31
8	INSPECTION STANDARD	32~35

1. BASIC SPECIFICATION

1.1 Mechanical specifications

Items	Nominal Dimension	Unit
Active screen size	4.3" diagonal	-
Dot Matrix	480 x RGB x 272	Pixel
Module Size (W x H x T)	105.5 x 67.2 x 5.45	mm.
Active Area (W x H)	95.04 x 53.856	mm.
Pixel Size (W×H)	0.198 x 0.198	mm.
Color depth	16.7M	color
Interface	Parallel 24-bit RGB	-
Driving IC Package	COG	-
Module weight	55	g

1.2 Display specification

Display	Descriptions	Note
LCD Type	a-Si TFT	-
LCD Mode	TN / Normal white	-
Polarizer Mode	Transmissive	-
Polarizer Surface	Normal	-
Pixel arrangement	RGB-stripe	-
Backlight Type	LED	-
Viewing Direction(Gray inversion)	6 O'clock Direction	-

* Color tone is slightly changed by temperature and driving voltage.

1.3 Outline dimension

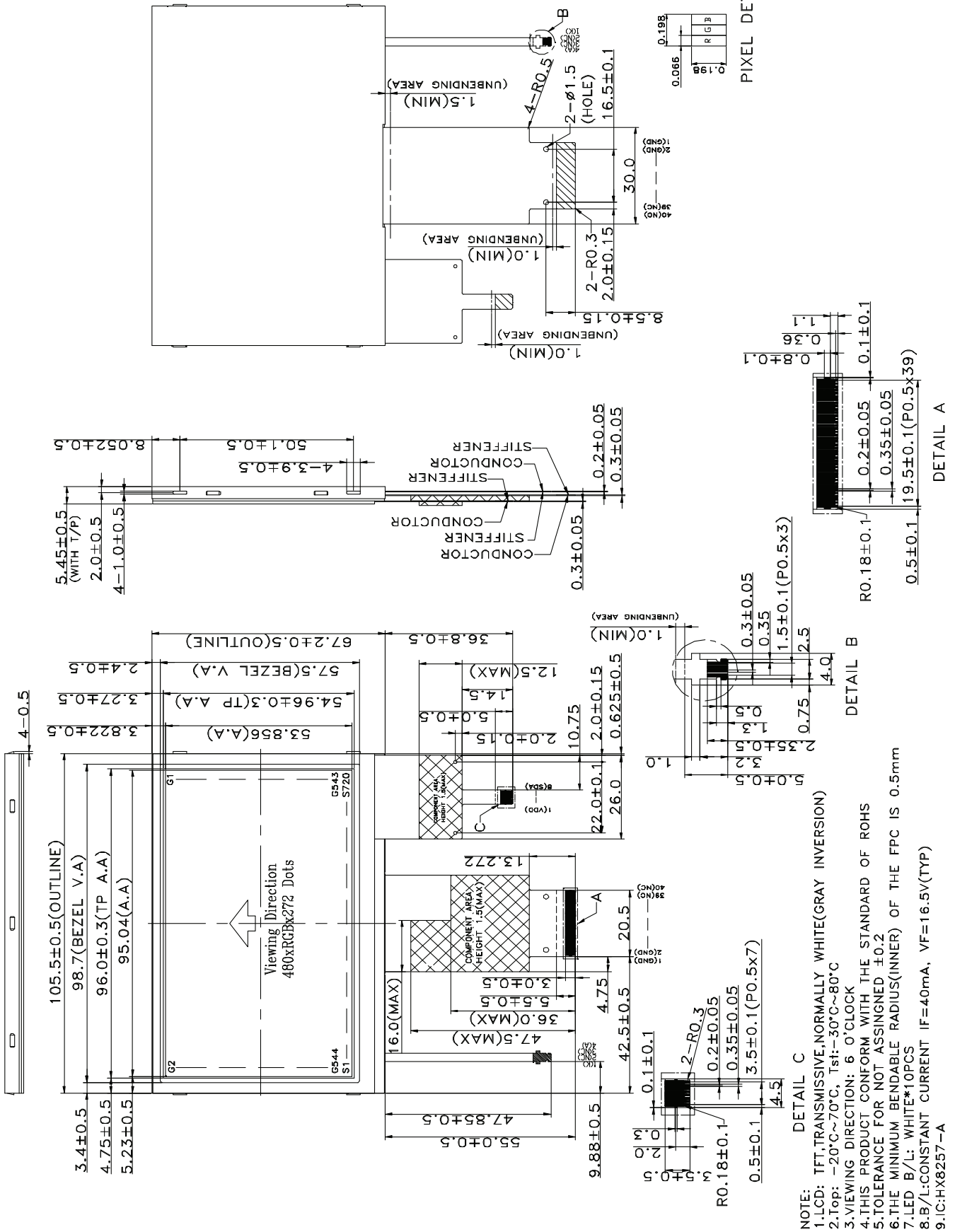

NOTE: TFT, TRANSMISSIVE, NORMALLY WHITE (GRAY INVERSION)

1. LCD: -20°C~70°C, Tst: -30°C~80°C

2. Top: -20°C~70°C, Tst: -30°C~80°C

3. VIEWING DIRECTION: 6 O'CLOCK

4. THIS PRODUCT CONFORM WITH THE STANDARD OF ROHS

5. TOLERANCE FOR NOT ASSIGNED ±0.2

6. THE MINIMUM BENDABLE RADIUS (INNER) OF THE FPC IS 0.5mm

7. LED B/L: WHITE*10PCS

8. B/L: CONSTANT CURRENT IF=40mA, VF=16.5V (TYP)

9. IC: HX8257-A

1.4 Block diagram:

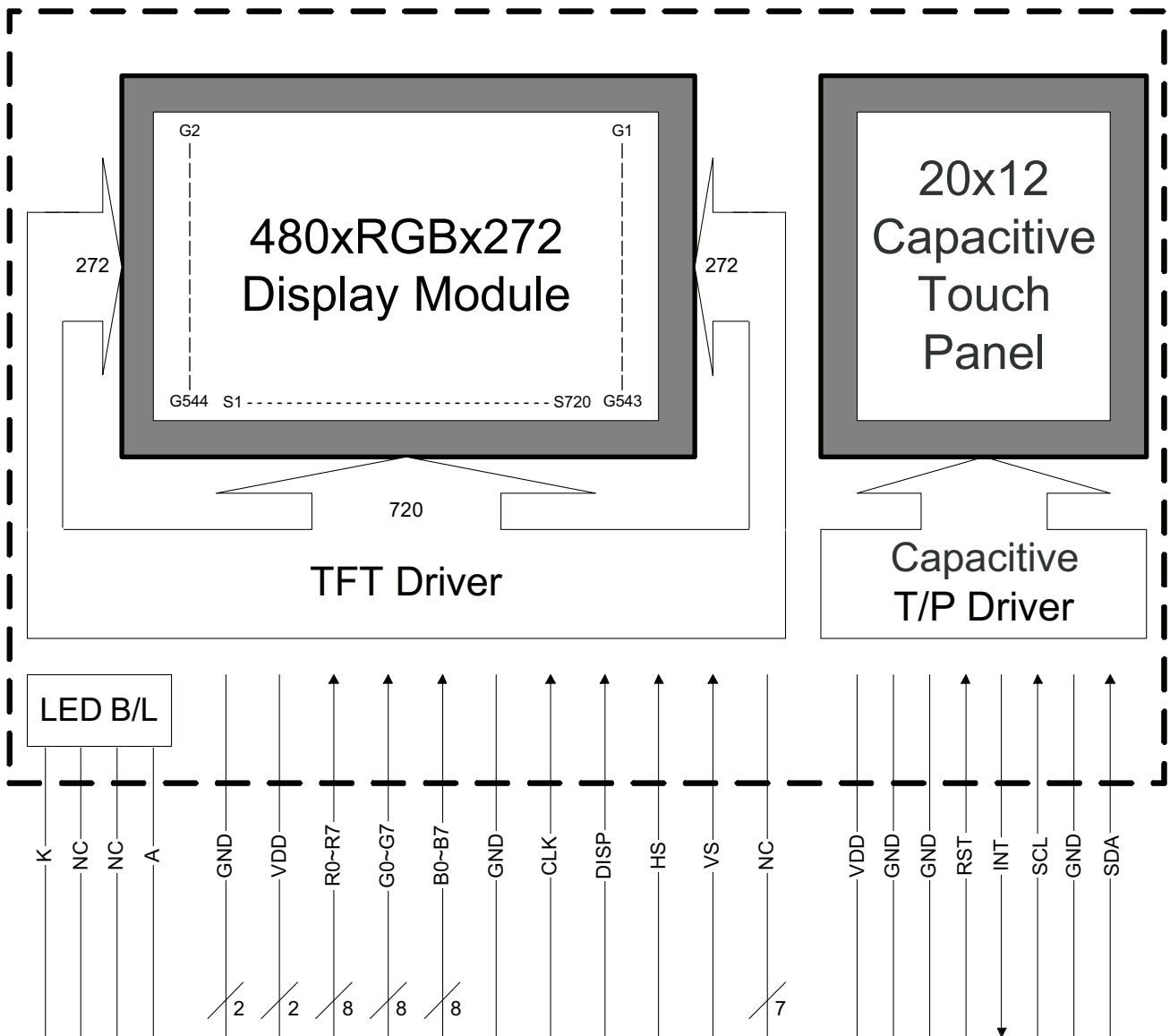

1.5 Interface pin :

Pin No.	Pin Symbol	I/O	Description
1 ~ 2	GND	P	Ground for logic. (0V)
3 ~ 4	VDD	P	Power supply. (+3.3V)
5 ~ 12	R0 ~ R7	I	Red data signal.
13 ~ 20	G0 ~ G7	I	Green data signal.
21 ~ 28	B0 ~ B7	I	Blue data signal.
29	GND	P	Ground for logic. (0V)
30	CLK	I	Clock signal for data latching and internal counter of the timing controller.
31	DISP	I	Display on/off mode control. Internally pulled high. (a) DISP=L, standby mode. (b) DISP=H, normal display mode.
32	HS	I	Horizontal sync input with negative polarity. Internally pull high.
33	VS	I	Vertical sync input with negative polarity. Internally pull high.
34 ~ 40	NC	-	No connect.

B/L interface pin :

Pin No.	Pin Symbol	I/O	Description
1	K	P	Ground pin for backlight.
2 ~ 3	NC	-	No connect.
4	A	P	Power supply input pin for backlight.

Capacitive touch panel pin:

Pin No.	Pin Symbol	I/O	Description
1	VDD	P	Power supply. (+3.3V)
2	GND	P	Ground for logic. (0V)
3	GND	P	Ground for logic. (0V)
4	RST	I	System reset signal input, active low.
5	INT	O	Active low when data output from touch panel.
6	SCL	I	Serial clock.
7	GND	P	Ground for logic. (0V)
8	SDA	I/O	Serial data access.

2. ELECTRICAL CHARACTERISTICS

2.1 Absolute Maximum Ratings

Items	Symbol	Min.	Max.	Unit
Power supply voltage	VDD	-0.3	4.0	V
Operate temperature range	T _{OP}	TBD	TBD	°C
Storage temperature range	T _{ST}	-30	80	°C

2.2 DC Characteristics

$T_a = 25^\circ\text{C}$

Items	Symbol	Min.	Typ.	Max.	Unit	Condition
Supply voltage	VDD	3.0	3.3	3.6	V	-
Input Voltage	V_{IL}	0	-	0.3VDD	V	L level
	V_{IH}	0.7VDD	-	VDD	V	H level
Current consumption	I_{VDD}	-	-	TBD	mA	Note 1

*Note1 :

Measuring Condition:

Standard Value MAX.

$T_a = 25^\circ\text{C}$

VDD -GND = 3.3V

Display Pattern = Check pattern

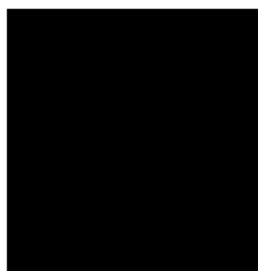

0 gray black pattern

2.2.1 Back-light Characteristics

PARAMETER	SYMBOL	MIN	TYP	MAX	Unit	Test Condition	NOTE
Supply Current	If	-	40	-	mA	$T_a = 25^\circ\text{C}$	-
Supply Voltage	Vf	-	16.5	-	V	$T_a = 25^\circ\text{C}$	-
Half-Life Time	Lf	-	50000	-	hrs	$T_a = 25^\circ\text{C}$	1

Note 1 : The " Half-Life Time" is defined as the LED chip brightness decreases to 50% than original brightness, Based on $T_a 25 \pm 2^\circ\text{C}$, $60 \pm 10\%$ RH condition .

2.3 AC Characteristics

Parallel RGB Input Timing Requirement

Parameter	Symbol	Spec.			Unit
		Min.	Typ.	Max.	
Clock cycle	$f_{CLK}^{(1)}$	-	9	15	MHz
Hsync cycle	1/th	-	17.14	-	KHz
Vsync cycle	1/tv	-	59.94	-	Hz
Horizontal Signal					
Horizontal cycle	th	525	525	605	CLK
Horizontal display period	thd	480	480	480	CLK
Horizontal front porch	thf	2	2	82	CLK
Horizontal pulse width	thp ⁽²⁾	2	41	41	CLK
Horizontal back porch	thb ⁽²⁾	2	2	41	CLK
Vertical Signal					
Vertical cycle	tv	285	286	399	H ⁽¹⁾
Vertical display period	tvd	272	272	272	H ⁽¹⁾
Vertical front porch	tvf	1	2	227	H ⁽¹⁾
Vertical pulse width	tvp ⁽²⁾	1	10	11	H ⁽¹⁾
Vertical back porch	tvb ⁽²⁾	1	2	11	H ⁽¹⁾

Note: (1) Unit: CLK=1/ f_{CLK} , H= th,

(2) It is necessary to keep $tv_p+tv_b=12$ and $th_p+th_b=43$ in sync mode. DE mode is unnecessary to keep it.

Interface Timing Chart

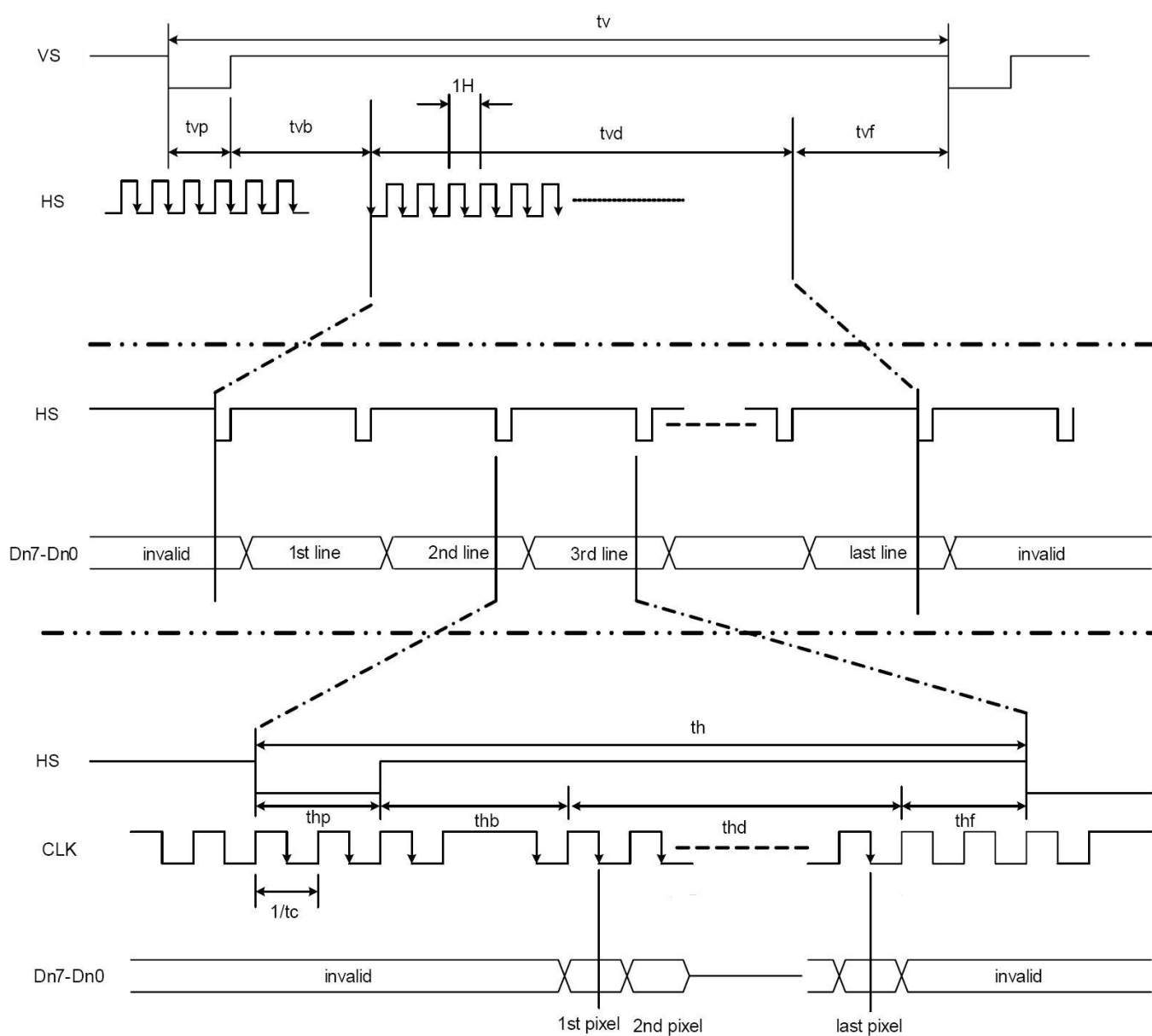

Parallel RGB Input timing

Input Setup Timing Requirement

Parameter	Symbol	Spec.			Unit
		Min.	Typ.	Max.	
DISP setup time	t_{diss}	10	-	-	ns
DISP hold time	t_{dish}	10	-	-	ns
Clock period	$PW_{CLK}^{(2)}$	66.7	-	-	ns
Clock pulse high period	$PWH^{(2)}$	26.7	-	-	ns
Clock pulse low period	$PWL^{(2)}$	26.7	-	-	ns
Hsync setup time	t_{hs}	10	-	-	ns
Hsync hold time	t_{hh}	10	-	-	ns
Data setup time	t_{ds}	10	-	-	ns
Data hold time	t_{dh}	10	-	-	ns
DE setup time	t_{des}	10	-	-	ns
DE hold time	t_{deh}	10	-	-	ns
Vsync setup time	t_{vhs}	10	-	-	ns
Vsync hold time	t_{vhh}	10	-	-	ns

Note: (1) t_r , t_f is defined 10% to 90% of signal amplitude.

(2) For parallel interface, maximum clock frequency is 15MHz.

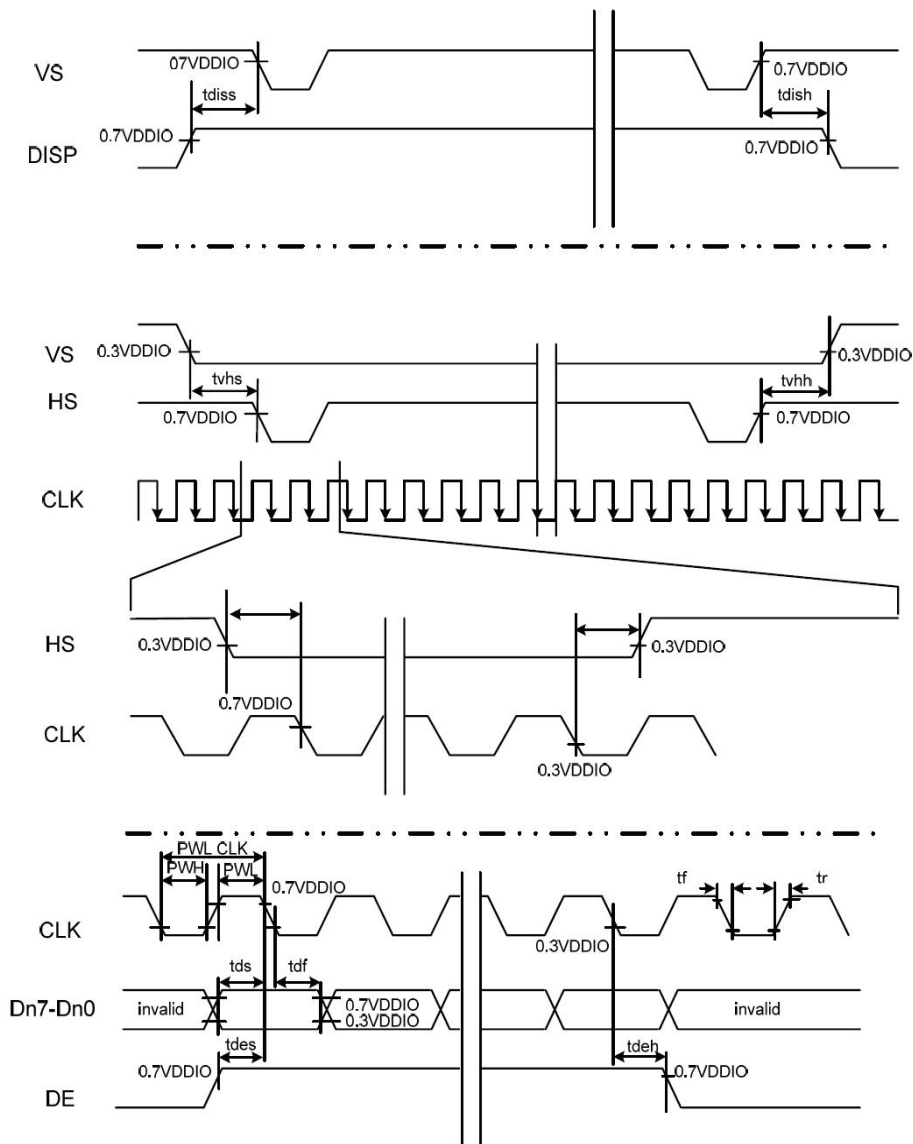

2.4 Capacitive touch panel controller Timing Specifications: (ST1232)

AC Electrical Characteristics

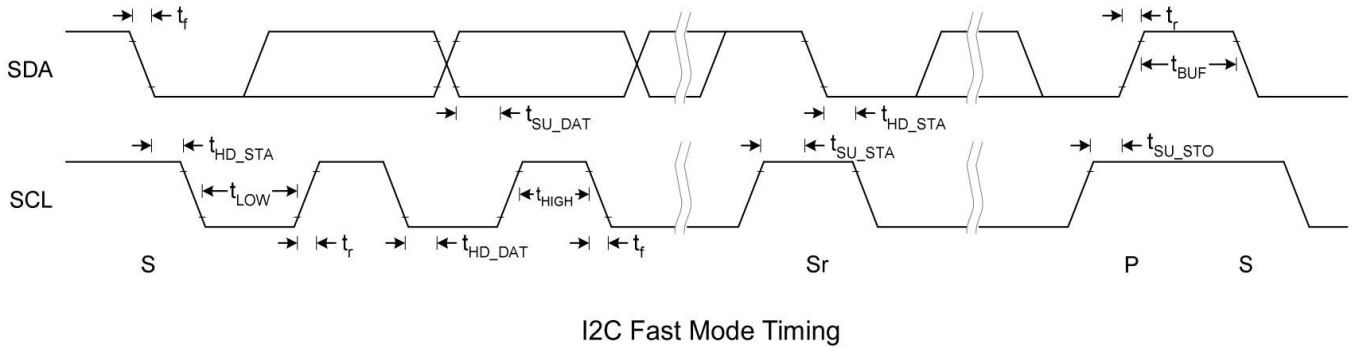

I2C Fast Mode Timing Characteristic

Conditions: VDD = IOVDD = 3.3V, GND = 0V, T_A = 25°C

Symbol	Parameter	Rating			Unit
		Min.	Typ.	Max.	
f _{SCL}	SCL clock frequency	0	-	400	kHz
t _{LOW}	Low period of the SCL clock	1.3	-	-	us
t _{HIGH}	High period of the SCL clock	0.6	-	-	us
t _f	Signal falling time	-	-	300	ns
t _r	Signal rising time	-	-	300	ns
t _{SU_STA}	Set up time for a repeated START condition	0.6	-	-	us
t _{HD_STA}	Hold time (repeated) START condition. After this period, the first clock pulse is generated	0.6	-	-	us
t _{SU_DAT}	Data set up time	100	-	-	ns
t _{HD_DAT}	Data hold time	0	-	0.9	us
t _{SU_STO}	Set up time for STOP condition	0.6	-	-	us
t _{BUF}	Bus free time between a STOP and START condition	1.3	-	-	us
C _b	Capacitive load for each bus line	-	-	400	pF

I2C Slave Interface

ST1232 equipped with I2C provide two wires, serial data (SDA) and serial clock (SCL), to carry information transfers at up to 400 kbit/s(Fast mode). ST1232 plays a slave role in I2C transfer. Both SDA and SCL are bidirectional lines, connected to IOVDD via pull-up resistors. All transactions begin with a START (S) and can be terminated by a STOP (P). 7-Bit address follows START to recognize device. Each byte is 8-bit length and followed by an acknowledge bit. A HIGH to LOW transition on the SDA line while SCL is HIGH defines a START condition. A LOW to HIGH transition on the SDA line while SCL is HIGH defines a STOP condition. The data on the SDA line must be stable during the HIGH period of the clock. The HIGH or LOW state of the data line can only change when the clock signal on the SCL line is LOW.

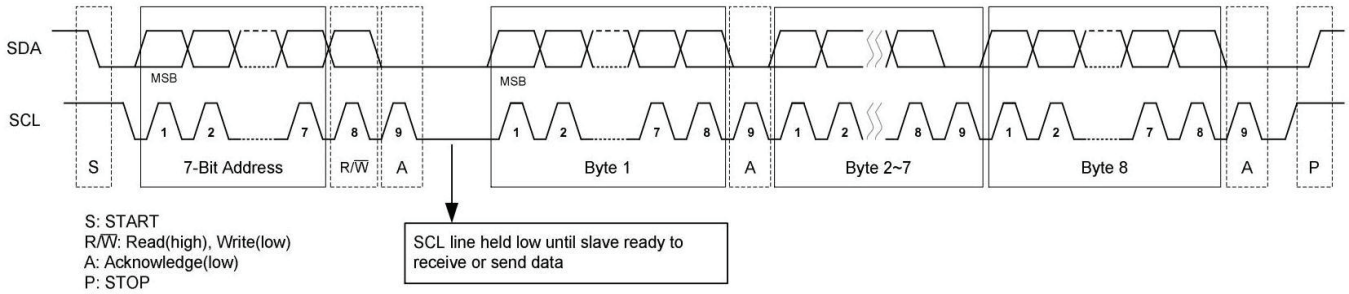

I2C Waveform

2.5 Capacitive touch panel controller I2C host interface protocol

2.5.1 Register Read

For reading register value from I2C device, host has to tell I2C device the *Start Register Address* before reading corresponding register value.

I2C Start	I2C Header (W)	Start Reg. Addr. (a)	I2C Stop	I2C Start	I2C Header (R)	Value of Reg(a)	Value of Reg(a+1)	...	Value of Reg(a+n)	I2C Stop
-----------	----------------	----------------------	----------	-----------	----------------	-----------------	-------------------	-----	-------------------	----------

ST1232/ST1332 I2C host interface protocol supports *Repeated Register Read*. That is, once the *Start Register Address* has been set by host, consequent I2C Read(R) transactions will directly read register values starting from the *Start Register Address* without setting address first, as shown in Figure 2.

I2C Start	I2C Header (R)	Value of Reg(a)	Value of Reg(a+1)	...	Value of Reg(a+n)	I2C Stop	I2C Start	I2C Header (R)	Value of Reg(a)	Value of Reg(a+1)	...	Value of Reg(a+n)	I2C Stop
-----------	----------------	-----------------	-------------------	-----	-------------------	----------	-----------	----------------	-----------------	-------------------	-----	-------------------	----------

2.5.2 Register Write

For writing register to I2C device, host has to tell I2C device the *Start Register Address* in each I2C Register Write transaction. Register values to the I2C device will be written to the address starting from the *Start Register Address* described in Register Write I2C transaction as shown in Figure 3.

I2C Start	I2C Header (W)	Start Reg. Addr. (a)	Value to Reg(a)	Value to Reg(a+1)	...	Value to Reg(a+n)	I2C Stop
-----------	----------------	----------------------	-----------------	-------------------	-----	-------------------	----------

2.6 Capacitive touch panel controller Report page registers

ST1232/ST1332 provides a register set for host to configure device attributes and retrieve information about fingers, proximity, gestures or raw data through device host interface. Host interface registers are listed below.

Host Interface Registers (Report Page)										
Reg. Addr.	Name	Bit 7	Bit 6	Bit 5	Bit 4	Bit 3	Bit 2	Bit 1	Bit 0	
0x00	Firmware Version	Version (RO)								
0x01	Status Reg.	Error Code (RO)				Device Status (RO)				
0x02	Device Control Reg.	Auto Tune (RW)	Reserved	Data Mode (RW)	Gest. Enable (RW)	Idle (RW)	Power Down (RW)	Reset (RW)		
0x03	Timeout to Idle Reg.	Timeout to Idle (sec.) (RW)								
0x04	XY Resolution (High Byte)	X_Res_H (RW)				Y_Res_H (RW)				
0x05	X Resolution (Low Byte)	X_Res_L (RW)								
0x06	Y Resolution (Low Byte)	Y_Res_L (RW)								
0x07	Max Drift Threshold	Max Drift Threshold (RW)								
0x08 ... 0x0F	...	Reserved								
0x10	Fingers / Gesture	Gesture Code (RO)					Fingers (RO)			
0x11	Keys Reg.	Keys (RO)								
0x12	XY0 Coord. (High Byte)	Valid 0 (RO)	X0_H (RO)			Reserved	Y0_H (RO)			
0x13	X0 Coord. (Low Byte)	X0_L (RO)								
0x14	Y0 Coord. (Low Byte)	Y0_L (RO)								
0x15	XY1 Coord. (High Byte)	Valid 1 (RO)	X1_H (RO)			Reserved	Y1_H (RO)			
0x16	X1 Coord. (Low Byte)	X1_L (RO)								
0x17	Y1 Coord. (Low Byte)	Y1_L (RO)								
0x18	Z0 Coord.	Z0 (RO)								
0x19	Z1 Coord.	Z1 (RO)								
0x1A ... 0x3F	...	Reserved								

Host Interface Registers (Report Page)

Reg. Addr.	Name	Bit 7	Bit 6	Bit 5	Bit 4	Bit 3	Bit 2	Bit 1	Bit 0
0x40	Raw Data [0] (High Byte)	Data_H [0]							
0x41	Raw Data [0] (Low Byte)	Data_L [0]							
0x42	Raw Data [1] (High Byte)	Data_H [1]							
0x43	Raw Data [1] (Low Byte)	Data_L [1]							
0x44	Raw Data [2] (High Byte)	Data_H [2]							
0x45	Raw Data [2] (Low Byte)	Data_L [2]							
...							
0x7E	Raw Data[31] (High Byte)	Data_H [31]							
0x7F	Raw Data [31] (Low Byte)	Data_L [31]							
0x80 ... 0xFE	...	<i>Reserved</i>							
0xFF	Page Reg.	Page Number (RW)							

2.6.1 Firmware Version Register

Reg. Addr.	Name	Bit 7	Bit 6	Bit 5	Bit 4	Bit 3	Bit 2	Bit 1	Bit 0
0x00	Firmware Version	Version (RO)							

Firmware Version Register provides version information about current firmware. Host application can support version control in firmware upgrade function by reading *Firmware Version Register* and comparing with the version of new firmware binary.

2.6.2 Firmware Version Register

Reg. Addr.	Name	Bit 7	Bit 6	Bit 5	Bit 4	Bit 3	Bit 2	Bit 1	Bit 0
0x01	Status Reg.	Error Code (RO)				Device Status (RO)			

Status Register shows current status of the device to host, including *Device Status* and *Error Code*. *Init* status represents that the device is in *Init* state and not ready for host access. Host has to wait for the device to change into *Normal* state before accessing registers other than *Status Register*. If *Device Status* shows *Error*, the *Error Code* field in the *Status Register* gives reason of the error.

Device Status	
0x0	Normal
0x1	Init
0x2	Error
0x3	Auto Tuning
0x4	Reserved
...	
0xF	

Error Code	
0x0	No Error
0x1	Invalid Address
0x2	Invalid Value
0x3	Reserved
...	
0xF	

2.6.3 Device Control Register

Reg. Addr.	Name	Bit 7	Bit 6	Bit 5	Bit 4	Bit 3	Bit 2	Bit 1	Bit 0
0x02	Device Control Reg.	Auto Tune (RW)	Reserved	Data Mode (RW)		Gest. Enable (RW)	Idle (RW)	Power Down (RW)	Reset (RW)

Device Control Register provides device control bits for host to reset the device, power down the device, change device state to idle, enable/disable proximity, enable/disable gestures or Data mode. Set Data Mode to 0x1 for Raw Data mode. Set Data Mode to 0x02 for Delta mode. Set Auto Tune to 0x1 will enable Auto Tune.

2.6.4 Timeout to Idle Register

Reg. Addr.	Name	Bit 7	Bit 6	Bit 5	Bit 4	Bit 3	Bit 2	Bit 1	Bit 0
0x03	Timeout to Idle Reg.	Timeout to Idle (sec.) (RW)							

Timeout to Idle Register provides timeout control to entering Idle Mode for host. The touch controller will enter Idle Mode after the number of seconds specified in Timeout to Idle Register if there is no touch detected in this period. The default value of Timeout to Idle Register is set to 0x08 for 8 seconds to Idle Mode.

2.6.5 XY Resolution Registers

Reg. Addr.	Name	Bit 7	Bit 6	Bit 5	Bit 4	Bit 3	Bit 2	Bit 1	Bit 0
0x04	XY Resolution (High Byte)	X_Res_H (RW)				Y_Res_H (RW)			
0x05	X Resolution (Low Byte)	X_Res_L (RW)							
0x06	Y Resolution (Low Byte)	Y_Res_L (RW)							

XY Resolution Registers represents resolution of X and Y coordinates of the touch screen. Host can change XY Resolution at run time by updating new resolution to these registers.

2.6.6 Max Drift Threshold

Reg. Addr.	Name	Bit 7	Bit 6	Bit 5	Bit 4	Bit 3	Bit 2	Bit 1	Bit 0
0x07	Max Drift Threshold	Max Drift Threshold (RW)							

Max Drift Threshold field defines the largest allowable drift in reported coordinates before issuing a new interrupt. Setting this field to 0 will disable Max Drift Threshold function. The default setting is 0.

2.6.7 Fingers and Gesture Register

Reg. Addr.	Name	Bit 7	Bit 6	Bit 5	Bit 4	Bit 3	Bit 2	Bit 1	Bit 0	
0x10	Fingers / Gesture	Gesture Code (RO)					Fingers (RO)			

Fingers field represents number of fingers detected by touch controller. The coordinates of each finger detected are represents in X Coordinate and Y Coordinate fields. *Gesture Register* tells host which gesture is detected by the controller. Gesture Codes for each gesture are listed below.

Gesture Code	
0x00	No Detected
0x01	Single Touch Tap
0x02	Single Touch Double Tap
0x03	Single Touch Slide Up
0x04	Single Touch Slide Down
0x05	Single Touch Slide Left
0x06	Single Touch Slide Right
0x07	Two Finger Slide Up
0x08	Two Finger Slide Down
0x09	Two Finger Slide Left
0x0A	Two Finger Slide Right
0x0B	Pinch In (Zoom In)
0x0C	Pinch Out (Zoom Out)
0x0D	Rotate CW (CCW, for Top Down Mapping)
0x0E	Rotate CCW (CW, for Top Down Mapping)
0x0F	<i>Reserved</i>
...	
0x1F	

2.6.8 Keys Register

Reg. Addr.	Name	Bit 7	Bit 6	Bit 5	Bit 4	Bit 3	Bit 2	Bit 1	Bit 0
0x11	Keys	Keys (RO)							

Key field represents which key is pressed or released. Each bit in the *Key* field represents the pressed or released state of one key. If the bit is set, it means that the corresponding key is pressed. Otherwise, the key is released.

2.6.9 XY Coordinate Registers

Reg. Addr.	Name	Bit 7	Bit 6	Bit 5	Bit 4	Bit 3	Bit 2	Bit 1	Bit 0
0x12	XY0 Coord. (High Byte)	Valid 0 (RO)	X0_H (RO)			Reserved	Y0_H (RO)		
0x13	X0 Coord. (Low Byte)	X0_L (RO)							
0x14	Y0 Coord. (Low Byte)	Y0_L (RO)							

XY Coordinate Registers represent the XY coordinates for each touch point ID. Valid bit field tells that this point ID is valid and the XY information represents a real touch point on touch sensor.

2.6.10 Z Coordinate Register

Reg. Addr.	Name	Bit 7	Bit 6	Bit 5	Bit 4	Bit 3	Bit 2	Bit 1	Bit 0
0x18	Z0 Coord.	Z0 (RO)							
0x19	Z1 Coord.	Z1 (RO)							

Z Coordinate Register indicates the touch strength of corresponding touch point ID. *Z0* represents touch strength of point ID 0 and *Z1* represents touch strength of point ID 1.

2.6.11 Data Registers

Reg. Addr.	Name	Bit 7	Bit 6	Bit 5	Bit 4	Bit 3	Bit 2	Bit 1	Bit 0
0x40	Data [0] (High Byte)	Data_H [0]							
0x41	Data [0] (Low Byte)	Data_L [0]							
0x42	Data [1] (High Byte)	Data_H [1]							
0x43	Data [1] (Low Byte)	Data_L [1]							
0x44	Data [2] (High Byte)	Data_H [2]							
0x45	Data [2] (Low Byte)	Data_L [2]							
...							
0x7E	Data[31] (High Byte)	Data_H [31]							
0x7F	Data [31] (Low Byte)	Data_L [31]							

Data Registers provide raw or delta data detected by touch sensor controller. If Data Mode of Device Control Register (0x02) is set to Raw Mode, Data Registers represent raw data. If Data Mode is set to Delta Mode, Data Registers represent delta data. Data Registers will be updated for each scan frame when in raw or delta mode. Otherwise, Raw Data Registers will not be updated.

2.6.12 Page Register

Reg. Addr.	Name	Bit 7	Bit 6	Bit 5	Bit 4	Bit 3	Bit 2	Bit 1	Bit 0
0xFF	Page Reg.	Page Number (RW)							

Page Register provides changing page of Host Interface Register. Default page is Report Page.

Page Number	Description
0x00	Report Page
0x01	AutoTune Page

2.7 Touch Panel Specifications

Display	Descriptions	Note
Type	Capacitive Touch Panel	-
Structure	ITO Film : T=0.7mm	-
	ITO Glass : T=0.7mm	-
Surface Hardness	$\geq 3H$	3H pencil, pressure 500g/45° (JIS-K5600)
Input mode	Finger	-
Connector Type	FPC	-
Resolution	480*272	1024*1024 (Max)

2.7.1 Electric Characteristics

Items	Descriptions	Note
FPC Strength (Vertical)	Strength $\geq 600g/cm$	-
FPC Bending	Min. 10 times for each side	Normal performance after bending 90° test, no damage on FPC.

3. OPTICAL CHARACTERISTICS

3.1 Characteristics

Electrical and Optical Characteristics

No.	Item	symbol / temp.	Min.	Typ.	Max.	Unit	Note	
1	Response Time	Tr	25 °C	-	5	ms	2	
		Tf	25 °C	-	15			
2	Viewing Angle	Hor.	Θ_{2+}	0°	60	75	degree	3
			Θ_{2-}	180°	60	75		
		Ver.	Θ_{1+}	270°	45	60		
			Θ_{1-}	90°	60	75		
3	Contrast Ratio	Cr	25 °C	300	500	-	4	
4	Red x-code	Rx	25 °C	0.56	0.61	0.66	-	5
	Red y-code	Ry		0.31	0.36	0.41		
	Green x-code	Gx		0.31	0.36	0.41		
	Green y-code	Gy		0.52	0.57	0.62		
	Blue x-code	Bx		0.10	0.15	0.20		
	Blue y-code	By		0.06	0.11	0.16		
	White x-code	Wx		0.27	0.32	0.37		
	White y-code	Wy		0.29	0.34	0.39		
	Brightness	Y		300	450	-	cd/m ²	
5	Brightness Uniformity		25 °C	80	-	-	%	6

3.2 Definition of optical characteristics

Measurement condition :

Transmissive and Transflective type

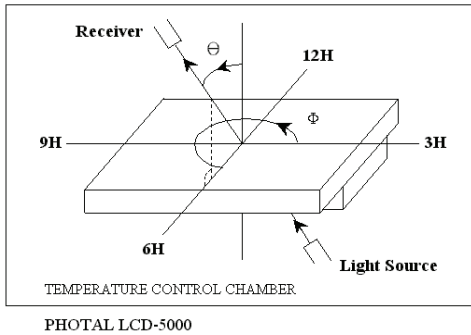

[Note 1] Definition of LCD Driving Vop and Waveform :

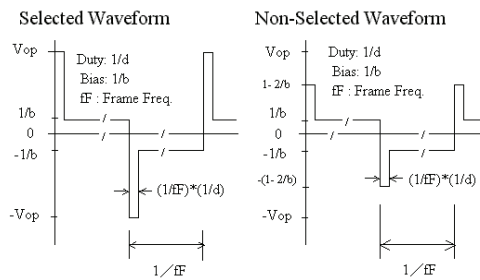
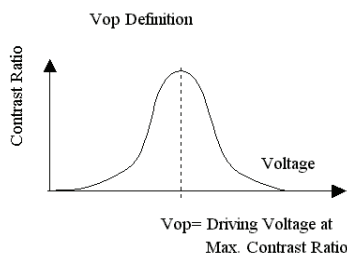

[Note 2] Definition of Response Time

for Positive type :

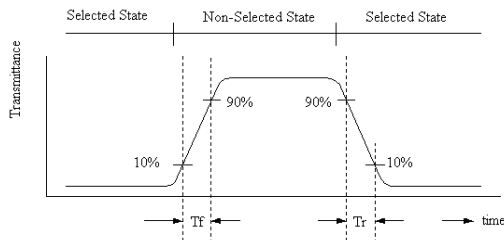

[Note 3] Definition of Viewing Angle :

[Note 4] Definition of Contrast Ratio :

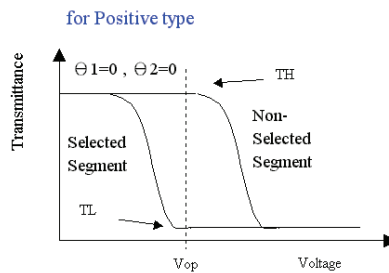
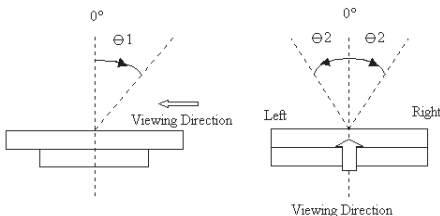

$$\text{Contrast Ratio} = \frac{TH}{TL}$$

[Note 5] Definition of measurement of Color Chromaticity and Brightness

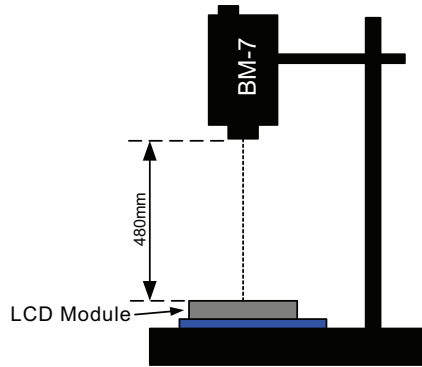

[Note 6] Definition of Brightness Uniformity

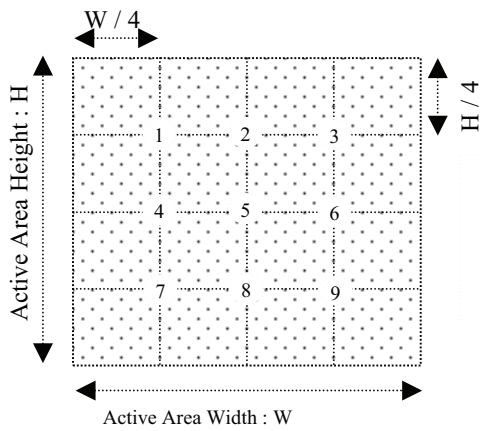

$$\text{Brightness Uniformity} = \frac{\text{Minimum Brightness of Point 1~9}}{\text{Maximum Brightness of Point 1~9}}$$

[Note 7] Definition of Measurement of Reflectance

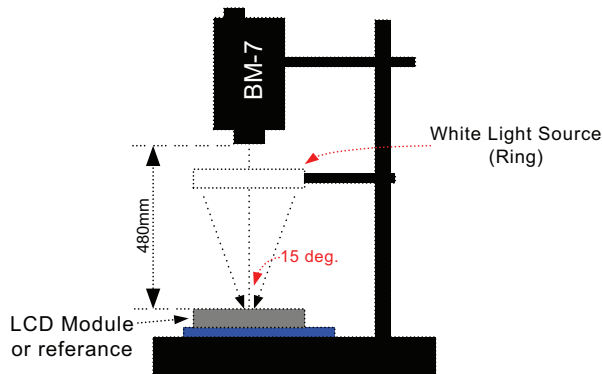

4. RELIABILITY :

Item No	Items	Condition
1	High temperature operating	70 °C , 200 hours
2	Low temperature operating	-20 °C , 200 hours
3	High temperature storage	80 °C , 200 hours
4	Low temperature storage	-30 °C , 200 hours
5	High temperature & humidity storage	60°C, 90%RH, 100 hours
6	Thermal Shock storage	-30°C, 30min.<=> 80°C, 30min. 10 Cycles
7	Vibration test	10 => 55 =>10 => 55 => 10 Hz , within 1 minute Amplitude : 1.5mm. 15 minutes for each Direction (X,Y,Z)
8	Drop test	Packed, 100CM free fall, 6 sides, 1 corner, 3edges
9	Life time	50,000 hours 25°C , 60%RH , specification condition driving

* One single product test for only one item.

* Judgment after test : keep in room temperature for more than 2 hours.

- Current consumption < 2 times of initial value
- Contrast > 1/2 initial value
- Function : work normally

5. PRODUCT HANDLING AND APPLICATION

PRECAUTION FOR HANDLING LCM

- The LCD module contains a C-MOS LSI. People who operate the LCM should wear ESD protection equipment to prevent ESD hurt on products.
- Do not input any signal before power is turned on.
- Do not take LCM from its packaging bag until it is assembled.
- Peel off the LCM protective film slowly since static electricity may be generated.
- Pay attention to the humidity of the work shop, 50~60%RH is satisfactory.
- Use a non-leak iron for soldering LCM.
- Do not touch the display surface or connection terminals area with bare hands. Smudges on the display surface reduce the insulation between terminals.
- Cautions for soldering to LCM:
Condition for soldering I/O terminals:
Temperature at iron tip :350°C±15°C.
Soldering time : 3~4sec./ terminals.
Type of solder : Eutectic solder(rosin flux filled).

PRECAUTION IN USE OF LCD

- Do not contact or scratch the front surface and the contact pads of a LCD panel with hard materials such as metal or glass or with one's nail.
- To clean the surface , wipe it gently with soft cloth dampened by alcohol.
- Do not attempt to wipe off the contact pads.
- Keep LCD panels away from direct sunlight , also avoid them in high-temperature & high humidity environment for a long period.
- Do not drive LCD panels by DC voltage.
- Do not expose LCD panels to organic solvent.
- Liquid in LCD is hazardous substance. In case a contact with liquid crystal material is occurred, be sure to immediately wash such material away by soap and water.
- The polarizer is easily damaged and should be handle with special care. Don't press or rub it with hard objects.

PRECAUTION FOR STORING AND USE OF LCM

- To avoid degradation of the device , do not store the module under the conditions of direct sunlight , high temperature or high humidity . Keep the module in bags designed to prevent static electricity charging under low temperature / normal humidity conditions(avoid high temperature / high humidity and low temperature below 0°C)
- Never use the LCD , LCM under 45 Hz , the liquid crystal will decomposition and cause permanently damage on display !!

USING ON MEDICAL CARE , SAFETY OR HAZARDOUS APPLICATION OR SYSTEM

- For the application in medical care, safety and hazardous products or systems, an authorization from O VV is required. O VV will not responsible for any damage or loss which caused by the products without any authorization given by O VV.
- This product is not allowed to be designed and used for military application and/or purpose.
- The delivery of this product to the countries and/or regions where the embargoes are imposed by U.N. is prohibited.
- The application and delivery of this product must comply with Strategic High-Tech Commodities (SHTC) export control and the sales to the embargoed and/or sanctioned countries or regions are strictly prohibited.

6. DATE CODE OF PRODUCTS

- Date code will be shown on each product :

- YY MM DD - XXXX

| | | |
Year Month Day - Production lots

- Example: 090508 - 0 0 0 3 ==>Year 2009, May.,08rd , Batch no.03

7. PACKING

Instruction of lot number:

LOT NO. : 0 0 0 8 3 5 2 5 (EX)

Date	01-1 st 02-2 nd 31-31 th
Week	1 — 6
Week of Month	1 — 5
Month	01- January 02- February 12- December
Year	00-2000 01-2001

Label of carton:

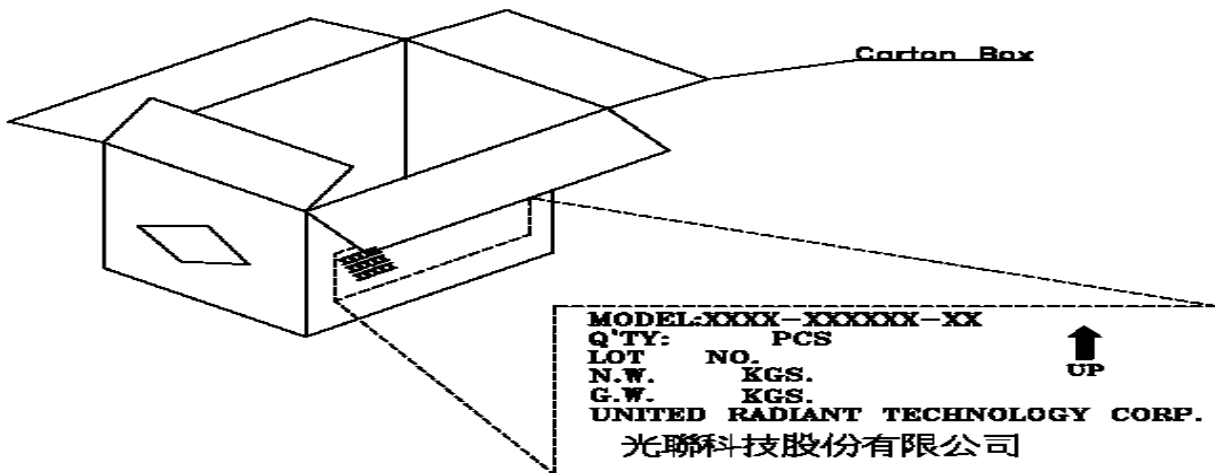

Packing tray must be stacked with alternated direction to each others.
To tacks packing trays in same direction will cause product damaged.

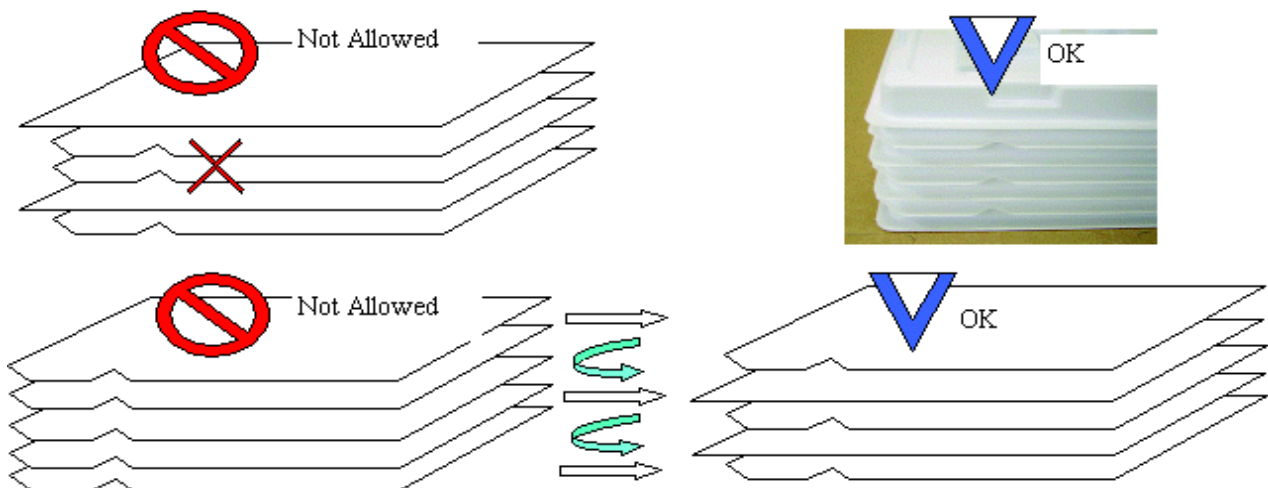

MODEL NO: UM*

T.B.D.pcs / Tray

T.B.D.Tray / Box

T.B.D. Box / Carton

T.B.D.pcs / Carton

NOTE:

(1) Be warned, the direction of the tray has to turn it by 180 degree before stack it up. Otherwise, it will be packager's responsibility!!

(2) Safe Stack : 5 cartons only

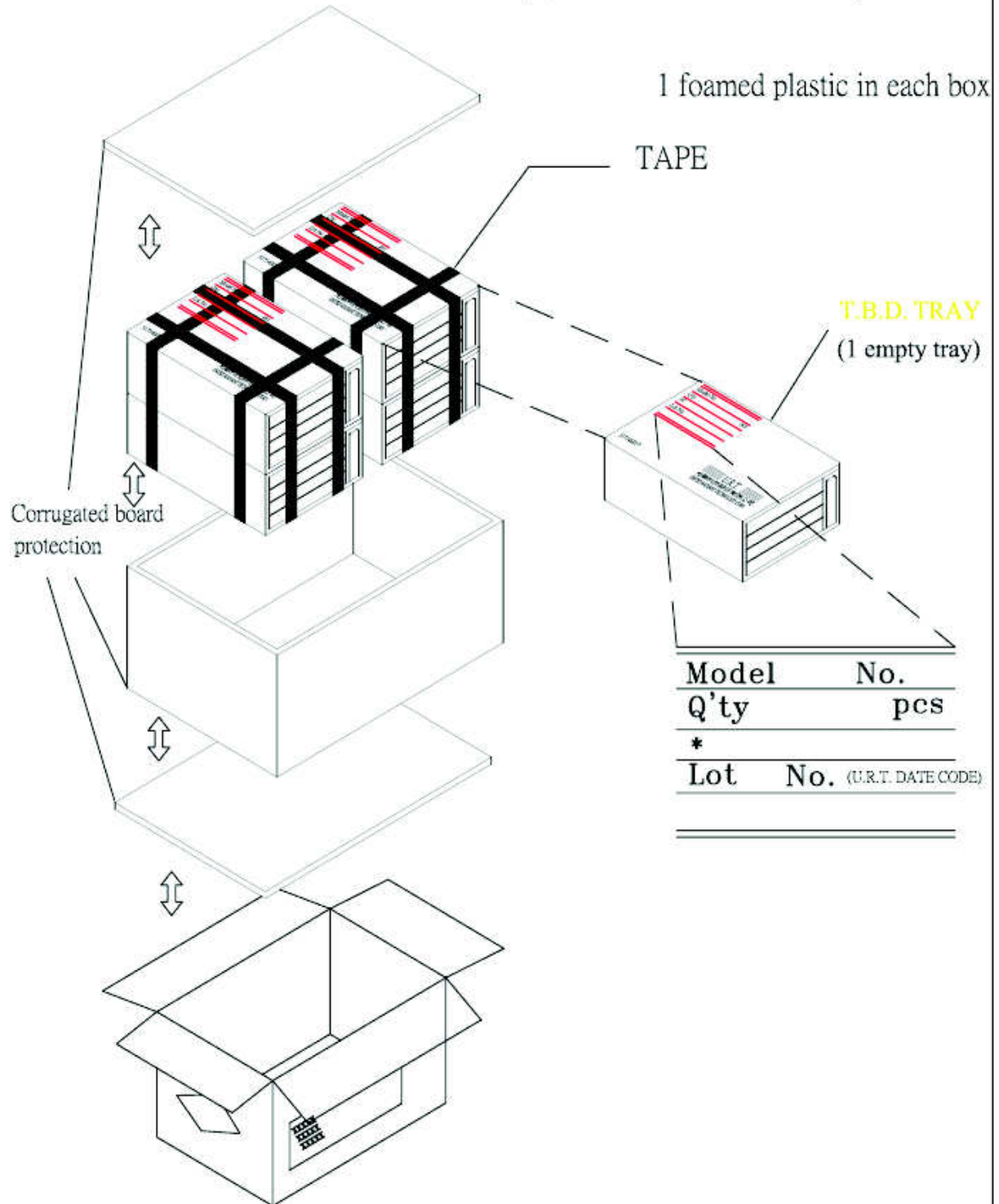

8. INSPECTION STANDARD

8.1. QUALITY :

THE QUALITY OF GOODS SUPPLIED TO PURCHASER SHALL COME UP TO THE FOLLOWING STANDARD.

8.1.1. THE METHOD OF PRESERVING GOODS

AFTER DELIVERY OF GOODS FROM O.V.V. TO PURCHASER. PURCHASER SHALL CONTROL THE LCM AT $-10^{\circ}\text{C} \sim 40^{\circ}\text{C}$, AND IT MIGHT BE DESIRABLE TO KEEP AT THE NORMAL ROOM TEMPERATURE AND HUMIDITY UNTIL INCOMING INSPECTION OR THROWING INTO PROCESS LINE.

8.1.2. INCOMING INSPECTION

(A) THE METHOD OF INSPECTION

IF PURCHASER MAKE AN INCOMING INSPECTION, A SAMPLING PLAN SHALL BE APPLIED ON THE CONDITION THAT QUALITY OF ONE DELIVERY SHALL BE REGARDED AS ONE LOT.

(B) THE STANDARD OF QUALITY

ISO-2859-1 (or MIL-STD-105E), LEVEL II SINGLE PLAN.

CLASS	AQL(%)
CRITICAL	0.4 %
MAJOR	0.65 %
MINOR	1.5 %
TOTAL	1.5 %

EVERY ITEM SHALL BE INSPECTED ACCORDING TO THE CLASS.

(C) MEASURE

IF AS THE RESULT OF ABOVE RECEIVING INSPECTION, A LOT OUT IS DISCOVERED. PURCHASER SHALL BE INFORM SELLER OF IT WITHIN SEVEN DAYS. BUT FIRST SHIPMENT WITHIN FOURTEEN DAYS.

8.1.3. WARRANTY POLICY

MTT WILL PROVIDE ONE-YEAR WARRANTY FOR THE PRODUCTS ONLY IF UNDER SPECIFICATION OPERATING CONDITIONS. MTT WILL REPLACE NEW PRODUCTS FOR THESE DEFECT PRODUCTS WHICH UNDER WARRANTY PERIOD AND BELONG TO THE RESPONSIBILITY OF MTT.

8.2. CHECKING CONDITION

8.2.1. CHECKING DIRECTION SHALL BE IN THE 45 DEGREE AREA TO FACE THE SAMPLE.

8.2.2. CHECKER SHALL SEE OVER 30 cm. WITH BARE EYES FAR FROM SAMPLE AND USING 2 PCS. OF 20W FLUORESCENT LAMP.

8.3. INSPECTION PLAN :

CLASS	ITEM	JUDGEMENT	CLASS
PACKING & INDICATE	1. OUTSIDE AND INSIDE PACKAGE	"MODEL NO." , "LOT NO." AND "QUANTITY" SHOULD INDICATE ON THE PACKAGE.	Minor
	2. MODEL MIXED AND QUANTITY	OTHER MODEL MIXED.....REJECTED QUANTITY SHORT OR OVER.....REJECTED	Critical
	3. PRODUCT INDICATION	"MODEL NO." SHOULD INDICATE ON THE PRODUCT	Major
ASSEMBLY	4. DIMENSION, LCD GLASS SCRATCH AND SCRIBE DEFECT.	ACCORDING TO SPECIFICATION OR DRAWING.	Major
APPEARANCE	5. VIEWING AREA	POLARIZER EDGE OR LCD'S SEALING LINE IS VISABLE IN THE VIEWING AREAREJECTED	Minor
	6. BLEMISH · BLACK SPOT · WHITE SPOT IN THE LCD AND LCD GLASS CRACKS	ACCORDING TO STANDARD OF VISUAL INSPECTION (INSIDE VIEWING AREA)	Minor
	7. BLEMISH · BLACK SPOT WHITE SPOT AND SCRATCH ON THE POLARIZER	ACCORDING TO STANDARD OF VISUAL INSPECTION (INSIDE VIEWING AREA)	Minor
	8. BUBBLE IN POLARIZER	ACCORDING TO STANDARD OF VISUAL INSPECTION (INSIDE VIEWING AREA)	Minor
	9. LCD'S RAINBOW COLOR	STRONG DEVIATION COLOR (OR NEWTON RING) OF LCD.....REJECTED. OR ACCORDING TO LIMITED SAMPLE (IF NEEDED, AND INSIDE VIEWING AREA)	Minor
ELECTRICAL	10. ELECTRICAL AND OPTICAL CHARACTERISTICS (CONTRAST · VOP · CHROMATICITY ... ETC)	ACCORDING TO SPECIFICATION OR DRAWING . (INSIDE VIEWING AREA)	Critical
	11.MISSING LINE	MISSING DOT · LINE · CHARACTERREJECTED	Critical
	12.SHORT CIRCUIT · WRONG PATTERN DISPLAY	NON DISPLAY · WRONG PATTERN DISPLAY · CURRENT CONSUMPTION OUT OF SPECIFICATION..... REJECTED	Critical
	13. PIN HOLE · PATTERN DEFORMITY	ACCORDING TO STANDARD OF VISUAL INSPECTION	Minor

8.4. STANDARD OF VISUAL INSPECTION

NO.	CLASS	ITEM	JUDGEMENT																																	
8.4.1	MINOR	<ul style="list-style-type: none"> · BLEMISH · BLACK SPOT · WHITE SPOT IN THE LCD. · BLEMISH · BLACK SPOT · WHITE SPOT AND SCRATCH ON THE POLARIZER 	<p>(A) ROUND TYPE: unit : mm.</p> <table border="1"> <thead> <tr> <th>DIAMETER (mm.)</th> <th>ACCEPTABLE Q'TY</th> </tr> </thead> <tbody> <tr> <td>$\Phi \leq 0.1$</td> <td>DISREGARD</td> </tr> <tr> <td>$0.1 < \Phi \leq 0.2$</td> <td>2</td> </tr> <tr> <td>$0.2 < \Phi \leq 0.25$</td> <td>1</td> </tr> <tr> <td>$0.25 < \Phi$</td> <td>0</td> </tr> </tbody> </table> <p>NOTE: $\Phi = (\text{LENGTH} + \text{WIDTH}) / 2$</p> <p>(B) LINER TYPE: unit : mm.</p> <table border="1"> <thead> <tr> <th>LENGTH</th> <th>WIDTH</th> <th>ACCEPTABLE Q'TY</th> </tr> </thead> <tbody> <tr> <td>-----</td> <td>$W \leq 0.03$</td> <td>DISREGARD</td> </tr> <tr> <td>$L \leq 5.0$</td> <td>$0.03 < W \leq 0.05$</td> <td>3</td> </tr> <tr> <td>$L \leq 5.0$</td> <td>$0.05 < W \leq 0.07$</td> <td>1</td> </tr> <tr> <td>-----</td> <td>$0.07 < W$</td> <td>FOLLOW ROUND TYPE</td> </tr> </tbody> </table>	DIAMETER (mm.)	ACCEPTABLE Q'TY	$\Phi \leq 0.1$	DISREGARD	$0.1 < \Phi \leq 0.2$	2	$0.2 < \Phi \leq 0.25$	1	$0.25 < \Phi$	0	LENGTH	WIDTH	ACCEPTABLE Q'TY	-----	$W \leq 0.03$	DISREGARD	$L \leq 5.0$	$0.03 < W \leq 0.05$	3	$L \leq 5.0$	$0.05 < W \leq 0.07$	1	-----	$0.07 < W$	FOLLOW ROUND TYPE								
DIAMETER (mm.)	ACCEPTABLE Q'TY																																			
$\Phi \leq 0.1$	DISREGARD																																			
$0.1 < \Phi \leq 0.2$	2																																			
$0.2 < \Phi \leq 0.25$	1																																			
$0.25 < \Phi$	0																																			
LENGTH	WIDTH	ACCEPTABLE Q'TY																																		
-----	$W \leq 0.03$	DISREGARD																																		
$L \leq 5.0$	$0.03 < W \leq 0.05$	3																																		
$L \leq 5.0$	$0.05 < W \leq 0.07$	1																																		
-----	$0.07 < W$	FOLLOW ROUND TYPE																																		
8.4.2	MINOR	BUBBLE IN POLARIZER	<p style="text-align: right;">unit : mm.</p> <table border="1"> <thead> <tr> <th>DIAMETER</th> <th>ACCEPTABLE Q'TY</th> </tr> </thead> <tbody> <tr> <td>$\Phi \leq 0.15$</td> <td>DISREGARD</td> </tr> <tr> <td>$0.15 < \Phi \leq 0.5$</td> <td>2</td> </tr> <tr> <td>$0.5 < \Phi$</td> <td>0</td> </tr> </tbody> </table>	DIAMETER	ACCEPTABLE Q'TY	$\Phi \leq 0.15$	DISREGARD	$0.15 < \Phi \leq 0.5$	2	$0.5 < \Phi$	0																									
DIAMETER	ACCEPTABLE Q'TY																																			
$\Phi \leq 0.15$	DISREGARD																																			
$0.15 < \Phi \leq 0.5$	2																																			
$0.5 < \Phi$	0																																			
8.4.3	MINOR	Dot Defect	<table border="1"> <thead> <tr> <th>Items</th> <th>ACC. Q'TY</th> </tr> </thead> <tbody> <tr> <td>Bright dot</td> <td>$N \leq 4$</td> </tr> <tr> <td>Dark dot</td> <td>$N \leq 4$</td> </tr> </tbody> </table> <p>Pixel Define</p> <table border="1"> <tbody> <tr> <td>R</td><td>G</td><td>B</td><td>R</td><td>G</td><td>B</td><td>R</td><td>G</td><td>B</td> </tr> <tr> <td>R</td><td>G</td><td>B</td><td>R</td><td>G</td><td>B</td><td>R</td><td>G</td><td>B</td> </tr> <tr> <td>R</td><td>G</td><td>B</td><td>R</td><td>G</td><td>B</td><td>R</td><td>G</td><td>B</td> </tr> </tbody> </table> <p>Not 1: The definition of dot: The size of a defective dot over 1/2 of whole dot is regarded as one defective dot. Not 2: Bright dot: Dots appear bright and unchanged in size in which LCD panel is displaying under black pattern. Not 3: Dark dot: Dots appear dark and unchanged in size in which LCD panel is displaying under pure red, green, blue pattern.</p>	Items	ACC. Q'TY	Bright dot	$N \leq 4$	Dark dot	$N \leq 4$	R	G	B	R	G	B	R	G	B	R	G	B	R	G	B	R	G	B	R	G	B	R	G	B	R	G	B
Items	ACC. Q'TY																																			
Bright dot	$N \leq 4$																																			
Dark dot	$N \leq 4$																																			
R	G	B	R	G	B	R	G	B																												
R	G	B	R	G	B	R	G	B																												
R	G	B	R	G	B	R	G	B																												

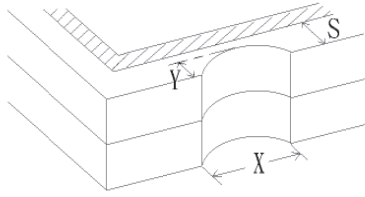
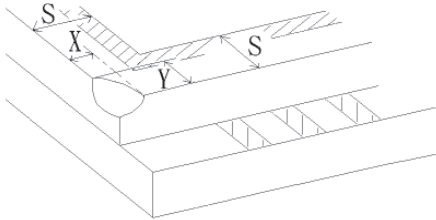
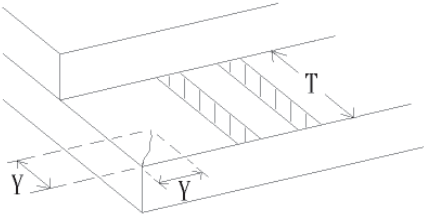
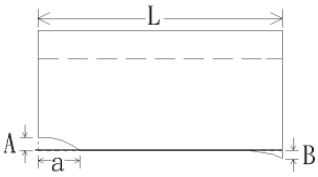
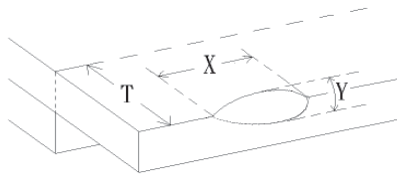
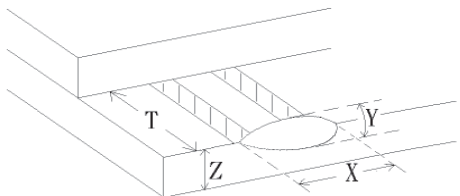
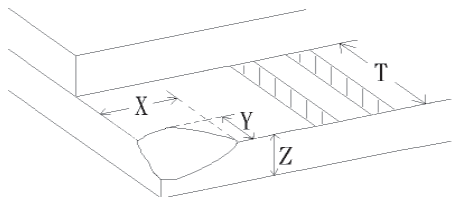
NO.	CLASS	ITEM	JUDGEMENT
8.4.4	MINOR	CHIPPING	 $Y > S$ REJ.
8.4.5	MINOR	CHIPPING	 $X \text{ or } Y > S$ REJ.
8.4.6	MAJOR	GLASS CRACK	 $Y > (1/2) T$ REJ.
8.4.7	MAJOR	SCRIBE DEFECT	 <ol style="list-style-type: none"> $a > L/3$, $A > 1.5\text{mm}$. REJ. B : ACCORDING TO DIMENSION
8.4.8	MINOR	CHIPPING (ON THE TERMINAL AREA)	 $\Phi = (x+y)/2 > 2.5 \text{ mm}$ REJ.
8.4.9	MINOR	CHIPPING (ON THE TERMINAL SURFACE)	 $Y > (1/3) T$ REJ.
8.4.10	MINOR	CHIPPING	 $Y > T$ REJ.



Компания «ЭлектроПласт» предлагает заключение долгосрочных отношений при поставках импортных электронных компонентов на взаимовыгодных условиях!

Наши преимущества:

- Оперативные поставки широкого спектра электронных компонентов отечественного и импортного производства напрямую от производителей и с крупнейших мировых складов;
- Поставка более 17-ти миллионов наименований электронных компонентов;
- Поставка сложных, дефицитных, либо снятых с производства позиций;
- Оперативные сроки поставки под заказ (от 5 рабочих дней);
- Экспресс доставка в любую точку России;
- Техническая поддержка проекта, помощь в подборе аналогов, поставка прототипов;
- Система менеджмента качества сертифицирована по Международному стандарту ISO 9001;
- Лицензия ФСБ на осуществление работ с использованием сведений, составляющих государственную тайну;
- Поставка специализированных компонентов (Xilinx, Altera, Analog Devices, Intersil, Interpoint, Microsemi, Aeroflex, Peregrine, Syfer, Eurofarad, Texas Instrument, Miteq, Cobham, E2V, MA-COM, Hittite, Mini-Circuits, General Dynamics и др.);

Помимо этого, одним из направлений компании «ЭлектроПласт» является направление «Источники питания». Мы предлагаем Вам помощь Конструкторского отдела:

- Подбор оптимального решения, техническое обоснование при выборе компонента;
- Подбор аналогов;
- Консультации по применению компонента;
- Поставка образцов и прототипов;
- Техническая поддержка проекта;
- Защита от снятия компонента с производства.



Как с нами связаться

Телефон: 8 (812) 309 58 32 (многоканальный)

Факс: 8 (812) 320-02-42

Электронная почта: org@eplast1.ru

Адрес: 198099, г. Санкт-Петербург, ул. Калинина, дом 2, корпус 4, литера А.