



PoE Microcontroller Unit

Description

PowerDsine's™ Microcontroller Unit, PD63000, is a member of Motorola's HCS08 Family of 8-bit microcontroller units (MCUs). This MCU uses the enhanced HCS08 core and is pre-programmed with a special proprietary application. It is used in conjunction with PowerDsine's PD64012 PoE Manager in Ethernet switches and Midspans to allow next generation network devices to share power and data over the same cable, according to IEEE 802.3af. When used in conjunction with the PD63000, the PD64012 operates in Enhanced mode.

The MCU features a 1 Mb/s SPI to each of the PoE Managers and a communication interface with the host CPU via UART or I²C protocol. The I/O lines, the SPI bus and the control signals are loaded by 50-ohm serial resistors. The MCU runs at about 10 MHz, providing a 1 MHz clock frequency to the SPI bus. An external resonator is used for clock generation.

The device is a Motorola's MC9S08GB60CFU microprocessor control unit – this is an 8-bit device composed of standard on-chip peripherals including: an 8-bit CPU, a 60-kbyte flash EEPROM, a 4-kbyte RAM, an asynchronous serial communications interface, a serial peripheral interface, a 3-channel timer and a 5-channel timer. In addition this chip includes: an 10-bit analog-to-digital converter.

Pin Configuration

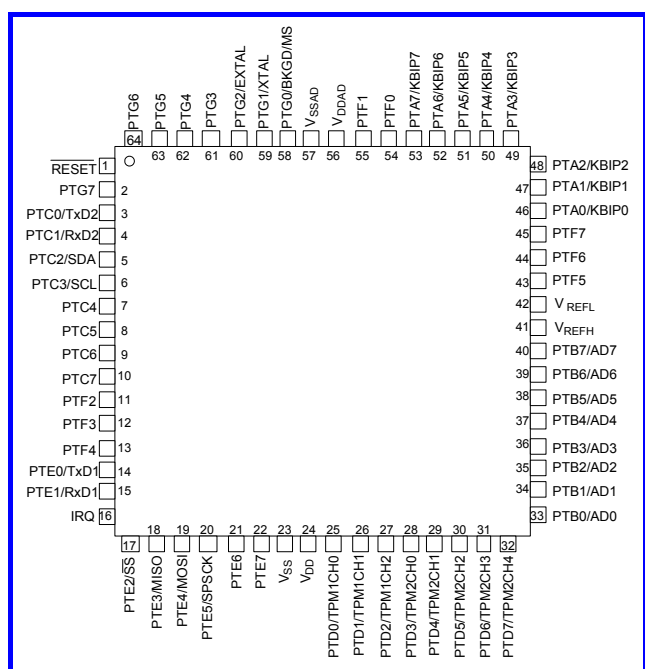

System Connectivity

In order to properly relate to the MCU in this document, a diagram of basic system connectivity is presented, hereafter. The various port groups are depicted along with their respective port lines. This block diagram can be compared with the application schematics from PowerDsine's Application Notes and Data Sheets, so as to understand the circuits used.

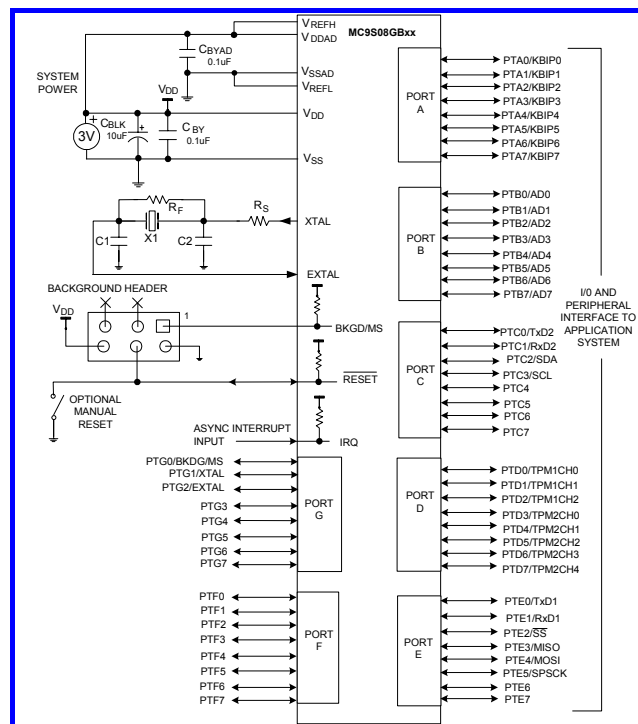

Program Burn-in

Initial burn-in is accomplished via the background header (BDM), by PowerDsine. Thereafter the MCU is downloaded with a special Powersdine program referred to as the PD64012 Enhanced Mode Software. This software can be downloaded via the UART port (pins 14 & 15, PTE0/TxD1 & PTE1/RxD1) or via the I²C port (pins 5 & 6, SDA & SCL.).

Applicable Documents

- IEEE 802.3af-2003 standard, DTE Power via MDI
- PowerDsine PD64012 Data Sheet, Cat. No. 06-0003-058
- Serial Communication Protocol, Cat. No. 06-0032-056
- PowerDsine Application Note 129 for Designing a 48-port Enhanced PoE System
- MC9S08GB/GT Data sheet (V1.5) 8-/16-Bit Products Division, Motorola, Inc.

Obtain from: http://e-www.motorola.com/files/microcontrollers/doc/data_sheet/MC9S08GB60.pdf

Package Information

The PD63000 is housed in a 64-pin LQFP plastic package, 10 x 10 x 1.4 mm, meeting JEDEC's MS-026 package outline and dimensions.

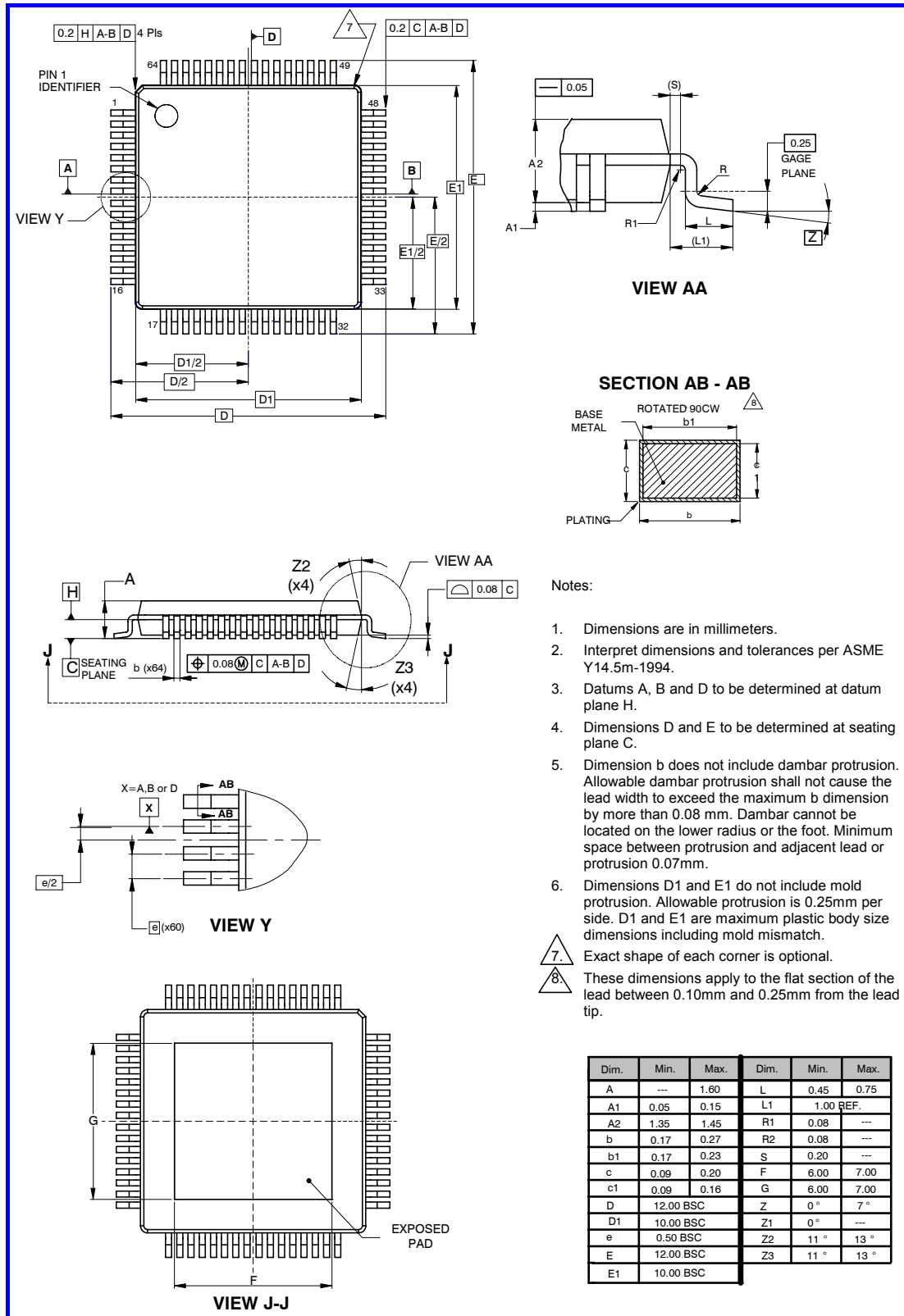



Pin Functionality

PIN	PIN NAME	PIN TYPE	PIN DESCRIPTION
1.	Reset	Digital input	xRESET_IN (1)
2.	PTG7		
3.	PTC0/TxD2	Digital I/O	
4.	PTC1/RxD2	Digital I/O	
5.	PTC2/SDA	Digital I/O	SDA
6.	PTC3/SCL	Digital I/O	SCL
7.	PTC4	Digital I/O	
8.	PTC5	Digital I/O	
9.	PTC6	Digital I/O	
10.	PTC7	Digital I/O	
11.	PTF2		
12.	PTF3		
13.	PTF4		
14.	PTE0/TxD1	Digital I/O	TX_3_3_V
15.	PTE1/RxD1	Digital I/O	RX_3_3_V
16.	IRQ	Digital input	xInt_in
17.	PTE2/SS	Digital I/O	
18.	PTE3/MISO	Digital I/O	MISO
19.	PTE4/MOSI	Digital I/O	MOSI
20.	PTE5/SPSCK	Digital I/O	SCK
21.	PTE6	Digital I/O	xDISABLE_PORTS
22.	PTE7	Digital I/O	
23.	VSS	Digital	D (ground)
24.	VDD	Digital	3_3VCPU
25.	PTD0/TPM1		Shorted to pin 28
26.	PTD1/TPM1		
27.	PTD2/TPM1		
28.	PTD3/TPM2		Shorted to pin 25
29.	PTD4/TPM2	Digital I/O	xSPI_CS0
30.	PTD5/TPM2	Digital I/O	xSPI_CS1
31.	PTD6/TPM2	Digital I/O	xSPI_CS2
32.	PTD7/TPM2	Digital I/O	xSPI_CS3
33.	PTB0/AD0	A/D input	

PIN	PIN NAME	PIN TYPE	PIN DESCRIPTION
34.	PTB1/AD1	A/D input	HW VER
35.	PTB2/AD2	A/D input	
36.	PTB3/AD3	A/D input	I2C_Init_E
37.	PTB4/AD4	A/D input	GND_Analog_CPU
38.	PTB5/AD5	A/D input	
39.	PTB6/AD6	A/D input	
40.	PTB7/AD7	A/D input	
41.	VREFH	A/D ref.	VREFH
42.	VREFL	A/D ref.	GND_Analog_CPU
43.	PTF5		
44.	PTF6		
45.	PTF7		
46.	PTA0/KBIP0	Digital I/O	xASIC_RESET (1)
47.	PTA1/KBIP1	Digital I/O	xDISABLE_PORTS_TO_ASIC (1)
48.	PTA2/KBIP2	A/D input	Power Good PG3 (2)
49.	PTA3/KBIP3	A/D input	Power Good PG2 (2)
50.	PTA4/KBIP4	A/D input	Power Good PG1 (2)
51.	PTA5/KBIP5	A/D input	
52.	PTA6/KBIP6		
53.	PTA7/KBIP7		
54.	PTF0		
55.	PTF1		
56.	VDDAD	Analog	VDDAD
57.	VSSAD	Analog	GND_Analog_CPU
58.	PTG0/BKGD/	Digital I/O	
59.	PTG1/XTAL	Resonator/o	XTAL
60.	PTG2/EXTAL	Resonator/o	EXTAL
61.	PTG3	Digital I/O	
62.	PTG4	Digital I/O	
63.	PTG5	Digital output	xInt_Out (future use)
64.	PTG6	Digital I/O	SELF RESET

- (1). Upon receiving an active low reset level via pin 1 (xRESET_IN) from the switch host, the PD63000 MCU immediately disables all PoE Manager (PD64012) output ports. The MCU does this using the xDISABLE_PORTS_TO_ASIC signal (pin 47). During this process, the PoE Managers are still actively operational, although their ports are disabled. Once the active low is released, the MCU performs a software reboot. After the reboot, the MCU sends a reset to all PoE Managers, via pin 46 (xASIC_RESET).
- (2). Refer to Tech Note TN-113 for information on power management.



Notice

PowerDsine assumes no responsibility or liability arising from the use of this Data Sheet, as described herein, nor does it convey any license under its patent rights or the rights of others.

The information contained herein is believed to be accurate and reliable at the time of printing. However, due to ongoing product improvements and revisions, PowerDsine cannot accept responsibility for inadvertent errors, inaccuracies, subsequent changes or omissions of printed material.

PowerDsine Ltd. reserves the right to make changes to products and to their specifications as described in this document, at any time, without prior notice. No rights to any PowerDsine Ltd. Intellectual property are licensed to any third party, directly, by implication or by any other method.

No Use with Life-Support or Critical Applications

PowerDsine's products are not designed, intended, or authorized for use as components in systems intended for:

- (1) surgical implant into the body, or other applications intended to support or sustain life, or
- (2) any other applications whereby a failure of the PowerDsine's product could create a situation where personal injury, death or damage to persons, systems, data or business may occur.

PowerDsine assumes no liability in connection with use in these situations and the disclaimers provided below in this manual shall apply. Should a buyer purchase or use PowerDsine's products for any such unintended use or unauthorized applications, buyer shall indemnify PowerDsine and its officers and employees against any and all claims arising out of or in connection with any claim of personal injury, death or other damage of the type described above, associated with such use.

DISCLAIMERS

POWERDSINE MAKES NO WARRANTY, REPRESENTATION OR GUARANTEE REGARDING THE SUITABILITY OF THE PRODUCTS CONTAINED HEREIN FOR ANY PARTICULAR PURPOSE, NOR DOES POWERDSINE ASSUME ANY LIABILITY ARISING OUT OF THE APPLICATION OR USE OF ANY PRODUCTS OR CIRCUIT, AND SPECIFICALLY DISCLAIMS ANY AN ALL LIABILITY, INCLUDING, WITHOUT LIMITATION, CONSEQUENTIAL OR INCIDENTAL DAMAGES. BY USING OUR PRODUCTS USER AGREES NOT TO MAKE ANY CLAIM FOR PUNITIVE DAMAGES.

POWERDSINE MAKES NO REPRESENTATION OR WARRANTY, EXPRESSED OR IMPLIED, WITH RESPECT TO THE SUFFICIENCY OR ACCURACY OR UTILITY OF ANY INFORMATION CONTAINED HEREIN. POWERDSINE EXPRESSLY ADVISES THAT ANY USE OF OR RELIANCE UPON SAID INFORMATION IS AT THE RISK OF THE USER AND THAT POWERDSINE SHALL NOT BE LIABLE FOR ANY DAMAGE OR INJURY INCURRED BY ANY PERSON OR ORGANIZATION ARISING OUT OF THE SUFFICIENCY, ACCURACY, OR UTILITY OF ANY INFORMATION CONTAINED HEREIN OR IN CONNECTION WITH THE USE OF ANY OF THE PRODUCTS DESCRIBED HEREIN. POWERDSINE IS NOT RESPONSIBLE FOR ANY CHANGES IN THE SPECIFICATIONS OR ERRATA OF THIS PRODUCT. INFORMATION ON THE BASIC PRODUCT CAN BE FOUND AT MOTOROLA'S HOMEPAGE.

Revision History

Revision Level / Date	Para. Affected	Description
1.2 / 9 Feb. 04	Front & back pages	Added policy statement and replaced Cat. no.
1.3 / 12 Feb. 04	Pin Functionality (page 3)	Added pin descriptions and explanation related to reset.
1.4 / 10 Mar. 04	Pin Functionality (page 3)	Added definitions for power management pins (Power Good)

© 2004 PowerDsine Ltd.
All rights reserved.

PowerDsine is a registered trademark of PowerDsine LTD.
All other products or trademarks are property of their respective owners.
The product described by this manual is a licensed product of PowerDsine.



Компания «ЭлектроПласт» предлагает заключение долгосрочных отношений при поставках импортных электронных компонентов на взаимовыгодных условиях!

Наши преимущества:

- Оперативные поставки широкого спектра электронных компонентов отечественного и импортного производства напрямую от производителей и с крупнейших мировых складов;
- Поставка более 17-ти миллионов наименований электронных компонентов;
- Поставка сложных, дефицитных, либо снятых с производства позиций;
- Оперативные сроки поставки под заказ (от 5 рабочих дней);
- Экспресс доставка в любую точку России;
- Техническая поддержка проекта, помощь в подборе аналогов, поставка прототипов;
- Система менеджмента качества сертифицирована по Международному стандарту ISO 9001;
- Лицензия ФСБ на осуществление работ с использованием сведений, составляющих государственную тайну;
- Поставка специализированных компонентов (Xilinx, Altera, Analog Devices, Intersil, Interpoint, Microsemi, Aeroflex, Peregrine, Syfer, Eurofarad, Texas Instrument, Miteq, Cobham, E2V, MA-COM, Hittite, Mini-Circuits, General Dynamics и др.);

Помимо этого, одним из направлений компании «ЭлектроПласт» является направление «Источники питания». Мы предлагаем Вам помощь Конструкторского отдела:

- Подбор оптимального решения, техническое обоснование при выборе компонента;
- Подбор аналогов;
- Консультации по применению компонента;
- Поставка образцов и прототипов;
- Техническая поддержка проекта;
- Защита от снятия компонента с производства.



Как с нами связаться

Телефон: 8 (812) 309 58 32 (многоканальный)

Факс: 8 (812) 320-02-42

Электронная почта: org@eplast1.ru

Адрес: 198099, г. Санкт-Петербург, ул. Калинина, дом 2, корпус 4, литера А.