



Main

Range of product	Magelis iPC
Product or component type	Multi-touch screen
Processor name	Intel Core i3 4010U 1.7 GHz
Chipset type	Intel QM87
Free slots	1 Internal SATA HDD/SSD 1 CFAST
Display size	18.5 inch
Display colour	16777216 colors
Luminance	27.87 fc (300 cd/m ²)
Pixel resolution	4096 x 4096
Video controller type	Intel HD Graphics 4400
Operating system	Windows 7 multi-language
Software package	EcoStruxure secure connect advisor annual subscription cyber security license not included EcoStruxure operator terminal expert run time HMI license not included EcoStruxure machine SCADA expert run time HMI/SCADA on configured offer only EcoStruxure augmented operator advisor server augmented operator license not included Vijeo Citect DVD SCADA license not included

Complementary

Number of points	5
Terminal type	Touchscreen display
Memory type	RAM DDR3 8 GB internal
Data storage equipment	80 GB SSD back side for 1500000 h
Aspect ratio	16:9
Display type	LED Colour TFT LCD
Display resolution	1366 x 768 pixels WXGA
Backlight lifespan	50000 hours
View angle horizontal x vertical	160 x 170°
Touch panel	Projected capacitive technology (PCT)
Type of cooling	Fanless Passive
Watchdog timer	1...255 ms
Integrated connection type	HDMI with 1 RS232 with 1 male SUB-D 9, transmission rate: <= 115.2 kbits/s RS485/RS422 with 1 male SUB-D 9, transmission rate: <= 115.2 kbits/s Ethernet port with 2 RJ45, transmission rate: 10/100/1000 Mbit/s USB 3.0 type A with 2, transmission rate: 1.5/12/480 Mbit/s, 5 Gbit/s
Number of slots	1 mini PCI Express full-size
[Us] rated supply voltage	24 V DC +/- 20 % 100...240 V AC with additional adaptor HMIYPSMAC1
Power consumption in W	28...60 W
Mechanical robustness	7H hardness anti-scratch
Function available	Operate with water on screen
Width	19.21 in (488 mm)
Height	12.17 in (309 mm)
Depth	2.23 in (56.7 mm)

The information provided in this documentation contains general descriptions and/or technical characteristics of the products contained herein. This documentation is not intended as a substitute for and is not to be used for determining suitability or reliability of these products for specific user applications. It is the duty of any such user or integrator to perform the appropriate and complete risk analysis, evaluation and testing of the products with respect to the relevant specific application or use thereof. Neither Schneider Electric Industries SAS nor any of its affiliates or subsidiaries shall be responsible or liable for misuse of the information contained herein.

Cut-out dimensions	479.3 (+/- 1) x 300.3 (+/- 0.7)
Product weight	15.43 lb(US) (7 kg)
Main type	Performance

Environment

IP degree of protection	IP66 front panel
product certifications	AS/NZS CCC CE C-Tick RCM EAC
standards	CISPR 11 IEC 60950 IEC 61000-6-2 IEC 61000-6-4 UL 60950 FCC part 15 class A CSA C22.2 No 60950
directives	2004/108/EC - electromagnetic compatibility 2006/95/EC - low voltage directive 2011/65/EU - RoHS directive 1907/2006/EC - REACH directive 2012/19/EU - WEEE directive
pollution degree	2
ambient air temperature for operation	0...55 °C SSD 0...55 °C Cfast card 0...45 °C HDD
ambient air temperature for storage	-4...140 °F (-20...60 °C)
relative humidity	10...95 % non-condensing
operating altitude	2000
vibration resistance	1 gn 5...500 Hz HDD

Offer Sustainability

Green Premium product	Green Premium product
Compliant - since 1530 - Schneider Electric declaration of conformity	Compliant - since 1530 - Schneider Electric declaration of conformity
Reference not containing SVHC above the threshold	Reference not containing SVHC above the threshold
Available	Available
Available	Available
WARNING: Cancer and Reproductive Harm - www.P65Warnings.ca.gov	WARNING: Cancer and Reproductive Harm - www.P65Warnings.ca.gov

Dimensions

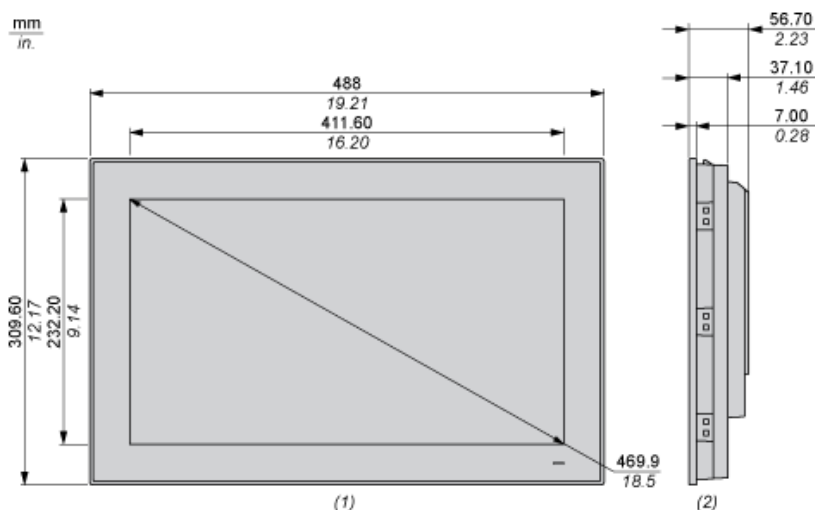

- (1) Front view
- (2) Side view

Spacing Requirements

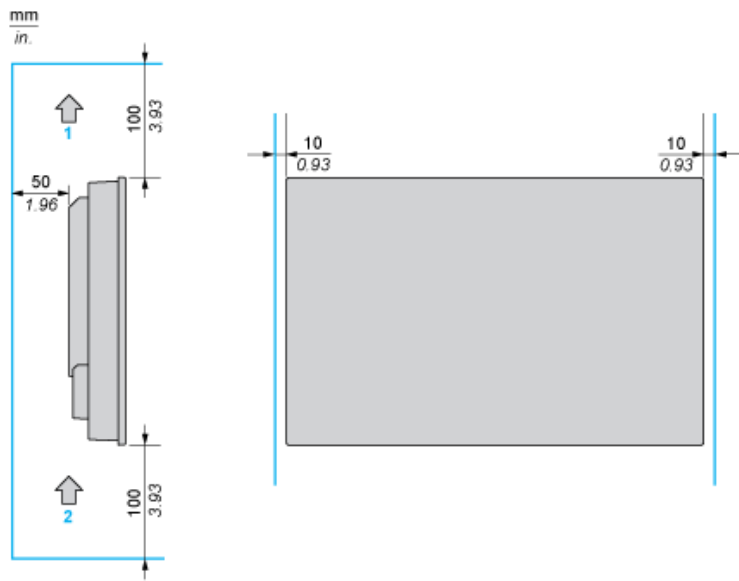

- (1) Air out
- (2) Air in

Mounting Orientation



Panel Cut Dimensions

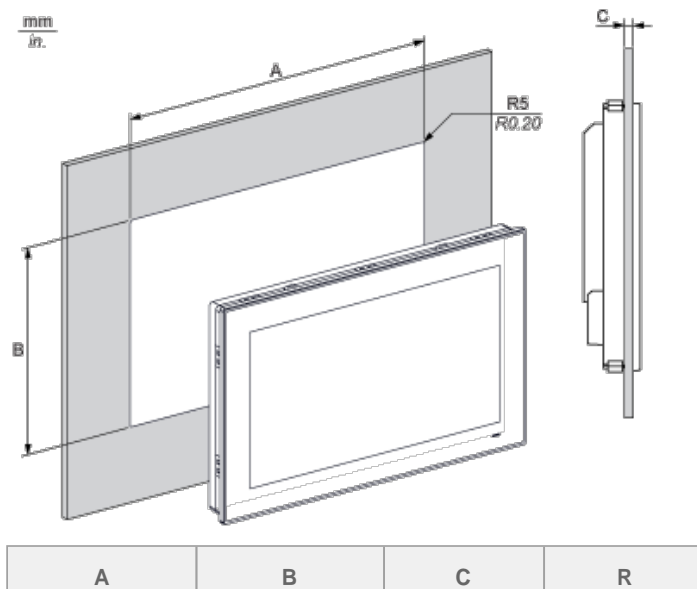

479.3 ±1 mm (18.87 ±0.04 in)	300.3 ±0.7 mm (11.82 ±0.03 in)	2...6 mm (0.08...0.23 in)	5 mm (0.20 in)
---------------------------------	-----------------------------------	------------------------------	-------------------



Компания «ЭлектроПласт» предлагает заключение долгосрочных отношений при поставках импортных электронных компонентов на взаимовыгодных условиях!

Наши преимущества:

- Оперативные поставки широкого спектра электронных компонентов отечественного и импортного производства напрямую от производителей и с крупнейших мировых складов;
- Поставка более 17-ти миллионов наименований электронных компонентов;
- Поставка сложных, дефицитных, либо снятых с производства позиций;
- Оперативные сроки поставки под заказ (от 5 рабочих дней);
- Экспресс доставка в любую точку России;
- Техническая поддержка проекта, помощь в подборе аналогов, поставка прототипов;
- Система менеджмента качества сертифицирована по Международному стандарту ISO 9001;
- Лицензия ФСБ на осуществление работ с использованием сведений, составляющих государственную тайну;
- Поставка специализированных компонентов (Xilinx, Altera, Analog Devices, Intersil, Interpoint, Microsemi, Aeroflex, Peregrine, Syfer, Eurofarad, Texas Instrument, Miteq, Cobham, E2V, MA-COM, Hittite, Mini-Circuits, General Dynamics и др.);

Помимо этого, одним из направлений компании «ЭлектроПласт» является направление «Источники питания». Мы предлагаем Вам помощь Конструкторского отдела:

- Подбор оптимального решения, техническое обоснование при выборе компонента;
- Подбор аналогов;
- Консультации по применению компонента;
- Поставка образцов и прототипов;
- Техническая поддержка проекта;
- Защита от снятия компонента с производства.



Как с нами связаться

Телефон: 8 (812) 309 58 32 (многоканальный)

Факс: 8 (812) 320-02-42

Электронная почта: org@eplast1.ru

Адрес: 198099, г. Санкт-Петербург, ул. Калинина, дом 2, корпус 4, литера А.