

40 MHz to 10GHz RMS Power Detector with 60dB Dynamic Range

DESCRIPTION

Demonstration circuit 1528A is a Mean-Squared Power Detector featuring the LTC[®]5582 IC.

The LTC5582 is a wide dynamic range Mean Squared RF Power Detector, operational from 40MHz to 6GHz. The input dynamic range with ± 1 dB nonlinearity is 60dB depending on frequency (from -58 dBm to $+2$ dBm, single-ended 50Ω input). The detector output voltage slope is normally 30mV/dB, and the typical

output variation over temperature is ± 0.5 dB at 2140MHz.

The DC1528A Demo Circuit is optimized for wide frequency range of 40MHz to 5.5GHz. However, input match can be optimized above 6GHz with simple external matching. Operating above 6GHz is possible with reduced performance. Contact applications for more information.

Design files for this demo board are available. Call the LTC factory.

Typical Performance Summary ($V_{CC} = 3.3V$, $V_{EN} = 3.3V$, $T_A = 25^\circ C$, unless otherwise noted. Test circuit shown in Figure 1.)

PARAMETER	CONDITION	VALUE
Supply Voltage		3.1V to 3.5V
Supply Current		41.6mA
Shutdown Current	EN = Low	0.1 μ A
EN Voltage	Low, Chip Disabled HIGH, Chip Enabled	0.4V max 1V min
EN Input Current	$V_{EN} = 0V$ $V_{EN} = 3.3V$	0 μ A 125 μ A
Output DC Voltage	No Input Signal Present	0.69V
Rise Time	0.8V to 2.4V, C3 = 8nF, $F_{RF} = 100$ MHz	90nS
Fall Time	2.4V to 0.8V, C3 = 8nF, $F_{RF} = 100$ MHz	5 μ S
Input Frequency Range	Operation over wider frequency range with reduced performance	40MHz to 10GHz
f = 2140MHz		
RF Input Power Range	CW; Single-Ended, 50Ω	-56dB to 1dB
Linear Dynamic Range	± 1 dB linearity error	57 dB
Slope		29.5mV/dB
Logarithmic Intercept		-85dBm
Output Variation vs Temperature	Normalized to Output at 25° , $P_{IN} = -47$ to $+0$ dBm	± 0.5 dB
Deviation from CW Response	12 dB peak-to-average ratio (4 carrier WCDMA)	0.1 dB
f = 5800MHz		
RF Input Power Range	CW; Single-Ended, 50Ω	-46dB to 3dB
Linear Dynamic Range	± 1 dB linearity error	49dB
Slope		30.9mV/dB

Logarithmic Intercept		-74.7
Output Variation vs Temperature	Normalized to Output at 25°C, P _{IN} = -46 to +2dBm	±1 dB
Deviation from CW Response	12dB Peak to Average Ratio(WiMAX OFDM)	0.2dB

QUICK START PROCEDURE

Demonstration circuit 1528A is easy to set up to evaluate the performance of the LTC5582. Care should be taken during V_{CC} power up, to ensure the supply voltage transient does not exceed the absolute maximum. Refer to Figure 2 for measurement equipment setup and follow the procedure below:

1. Connect voltmeter’s negative (-) lead to demo board GND test point (TP2).
2. Connect voltmeter’s positive (+) lead to the demo board VOUT test point (TP6).
3. Connect DC power supply’s negative (-) output to demo board GND test point (TP2).
4. Connect DC power supply’s positive (+) output (3.15V to 3.5V) to demo board V_{CC} test point (TP1).
5. Connect signal generator’s output to demo board RFIN port (SMA connector J1) via coaxial cable. An optional 3dB attenuator may be inserted to improve input match, the power range will be shifted higher by 3dB.
6. Using a jumper cable, connect demo board V_{CC} test point (TP1) to EN1 test point (TP3). Now the detector is enabled (on) and is ready for measurement.
7. Apply RF input signal at RFIN and measure the output DC voltage.

APPLICATION NOTES:

Absolute maximum ratings

- Supply voltage.....3.8V
- Enable voltage.....-0.3V to V_{CC} +0.3V
- Input signal Power(Single-ended, 50Ω).....18dBm
- Input signal Power(Differential, 50Ω).....24dBm
- Operating Temperature Range.....-40°C to 85°C

NOTE. For digitally modulated signals, an oscilloscope can be used to observe the AC components of the output.

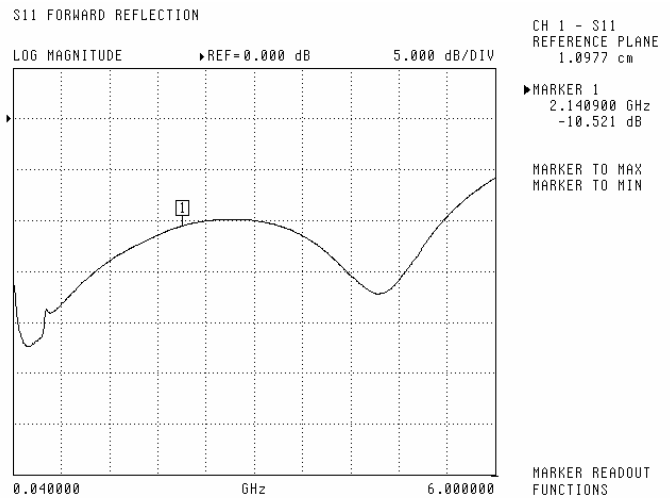

Figure 1. Standard demo board RF input return loss

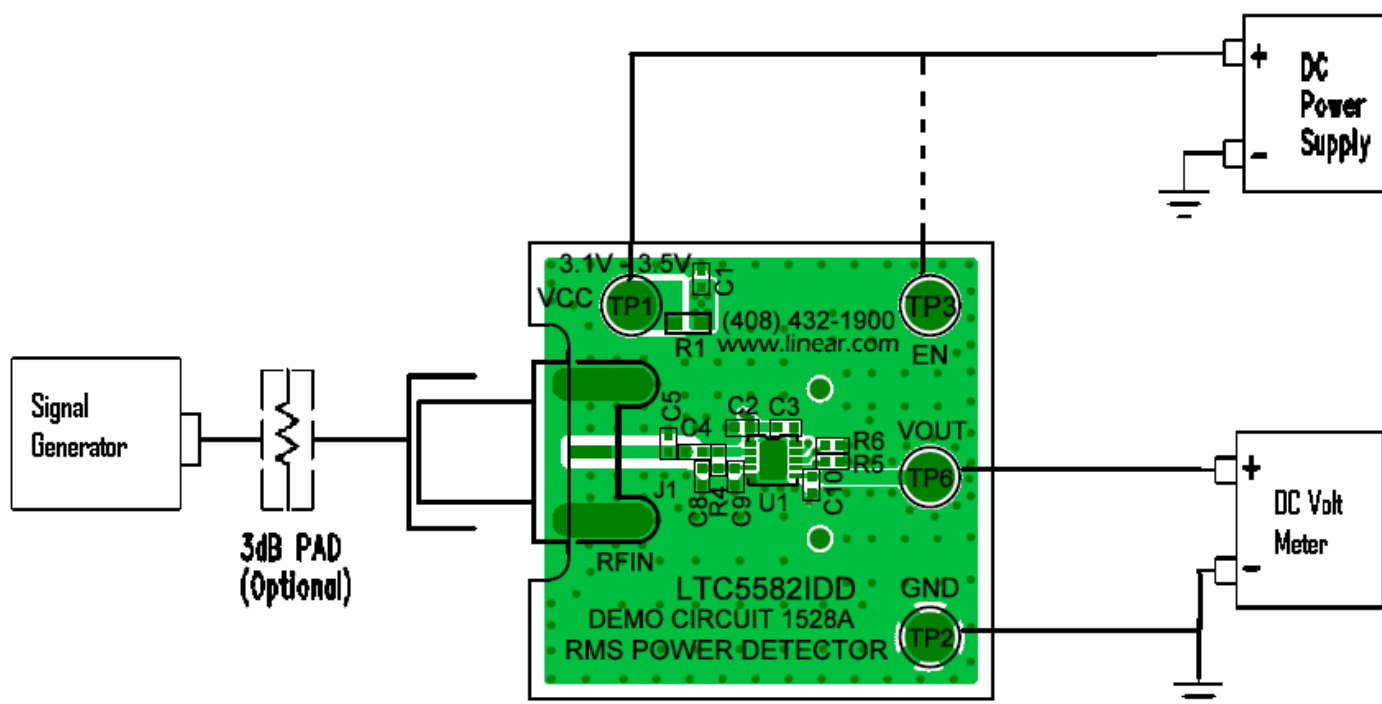

Figure2 Proper Equipment Measurement Set-Up

Temperature compensation

R5 and R6 are optional external resistors used for temperature compensation. Short them to ground will disable the compensation circuitry. R6 controls the 1st order compensation, and R5 controls the 2nd order temperature compensation. Standard demo board is optimized for the best temperature performance at 2140MHz.

Frequency(MHz)	R6,RT1(kΩ)	R5,RT2(kΩ)
450	12	2
800	12.4	1.4
880	12	2
2000	0	2
2140	0	2
2600	0	1.6
2700	0	1.6
3000	0	1.6
3600	0	1.6
5800	0	3
7000	10	1.43
8000	10	1.43

Table 1. Suggested R5, R6 values for optimal temperature performance at various frequencies.

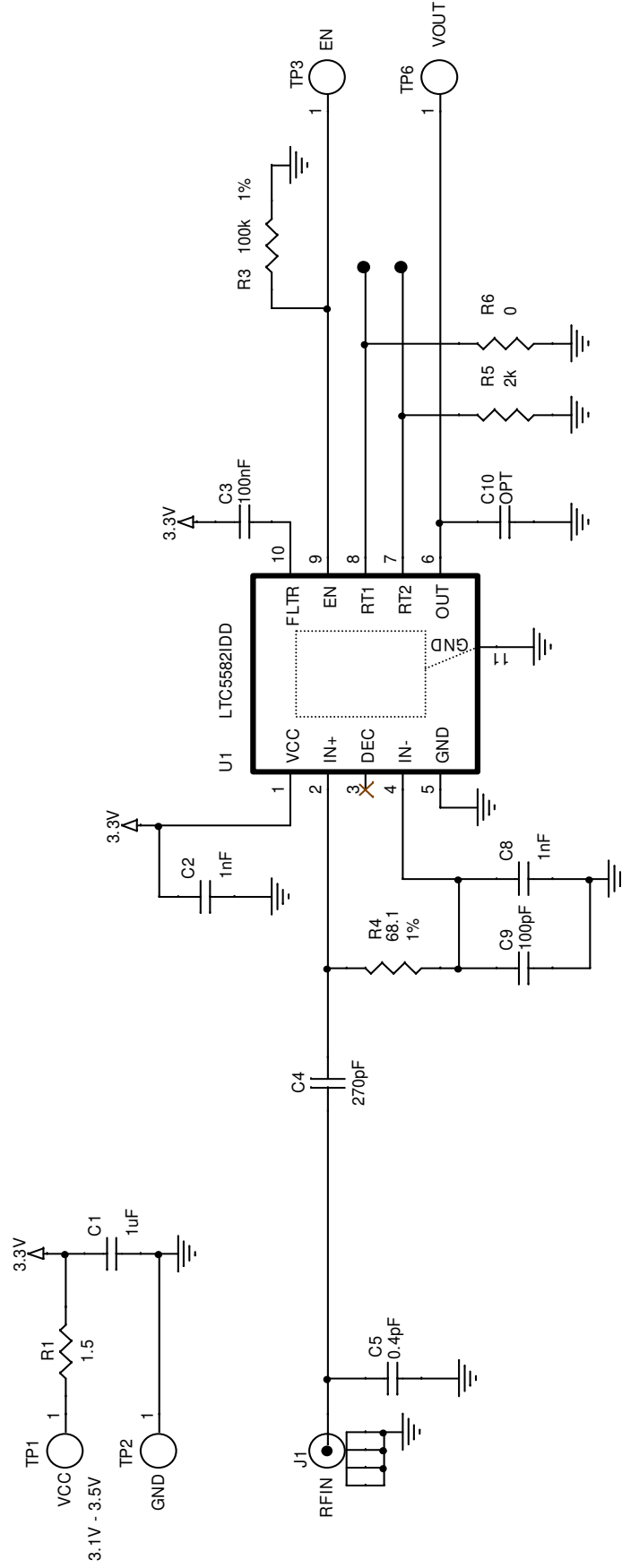



Компания «ЭлектроПласт» предлагает заключение долгосрочных отношений при поставках импортных электронных компонентов на взаимовыгодных условиях!

Наши преимущества:

- Оперативные поставки широкого спектра электронных компонентов отечественного и импортного производства напрямую от производителей и с крупнейших мировых складов;
- Поставка более 17-ти миллионов наименований электронных компонентов;
- Поставка сложных, дефицитных, либо снятых с производства позиций;
- Оперативные сроки поставки под заказ (от 5 рабочих дней);
- Экспресс доставка в любую точку России;
- Техническая поддержка проекта, помощь в подборе аналогов, поставка прототипов;
- Система менеджмента качества сертифицирована по Международному стандарту ISO 9001;
- Лицензия ФСБ на осуществление работ с использованием сведений, составляющих государственную тайну;
- Поставка специализированных компонентов (Xilinx, Altera, Analog Devices, Intersil, Interpoint, Microsemi, Aeroflex, Peregrine, Syfer, Eurofarad, Texas Instrument, Miteq, Cobham, E2V, MA-COM, Hittite, Mini-Circuits, General Dynamics и др.);

Помимо этого, одним из направлений компании «ЭлектроПласт» является направление «Источники питания». Мы предлагаем Вам помощь Конструкторского отдела:

- Подбор оптимального решения, техническое обоснование при выборе компонента;
- Подбор аналогов;
- Консультации по применению компонента;
- Поставка образцов и прототипов;
- Техническая поддержка проекта;
- Защита от снятия компонента с производства.



Как с нами связаться

Телефон: 8 (812) 309 58 32 (многоканальный)

Факс: 8 (812) 320-02-42

Электронная почта: org@eplast1.ru

Адрес: 198099, г. Санкт-Петербург, ул. Калинина, дом 2, корпус 4, литера А.