

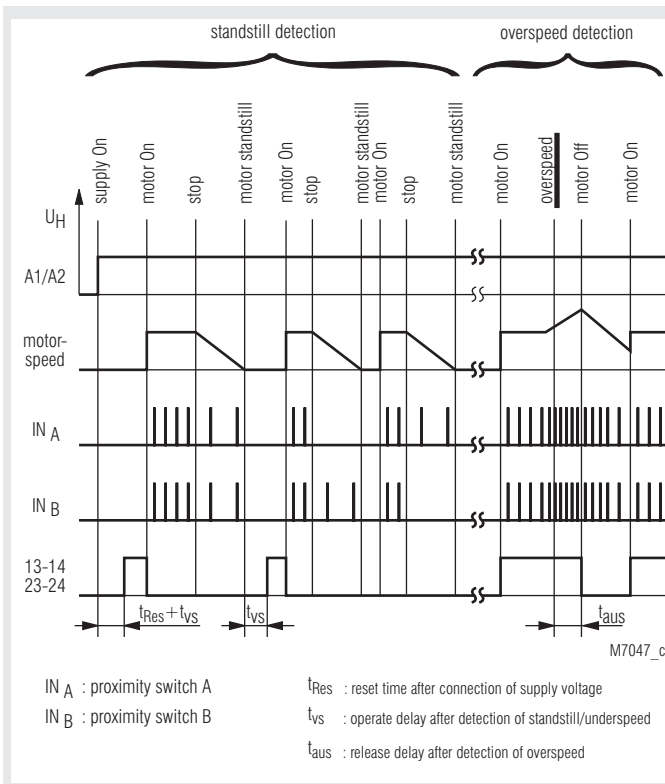

0223010

- According to
  - Performance Level (PL) e and category 3 to EN ISO 13849-1: 2008
  - SIL Claimed Level (SIL CL) 3 to IEC/EN 62061
  - Safety Integrity Level (SIL) 3 to IEC/EN 61508 and IEC/EN 61511
- For stop category 0 according to EN 418
- 2-channel input
- To monitor rotation and linear movement
- PNP proximity sensor inputs
- Optionally inputs for NPN proximity sensors
- Monitoring of connected sensor
- Fixed setting, adjustable as option
- Energized when speed is under setting value
- LED indication
- Feedback circuit X1 - X2 to monitor external contacts
- Forcibly guided contacts
- 2 NO, 1 NC contact
- Wire connection: also 2 x 1.5 mm<sup>2</sup> stranded ferruled (isolated), DIN 46 228-1/-2/-3/-4 or 2 x 2.5 mm<sup>2</sup> stranded ferruled DIN 46 228-1/-2/-3
- Width 45 mm

### Function Diagram



### Approvals and Marking



\* see variants

### Applications

Monitoring of speed or standstill also during setup operation

### Indication

Standstill monitoring:

1. green LED: on, when supply voltage connected
2. green LED: on, when standstill detected on channel 1
3. green LED: on, when standstill detected on channel 2

Overspeed monitoring:

1. green LED: on, when supply voltage connected
2. green LED: on, when no overspeed detected on channel 1
3. green LED: on, when no overspeed detected on channel 2

### Block Diagram

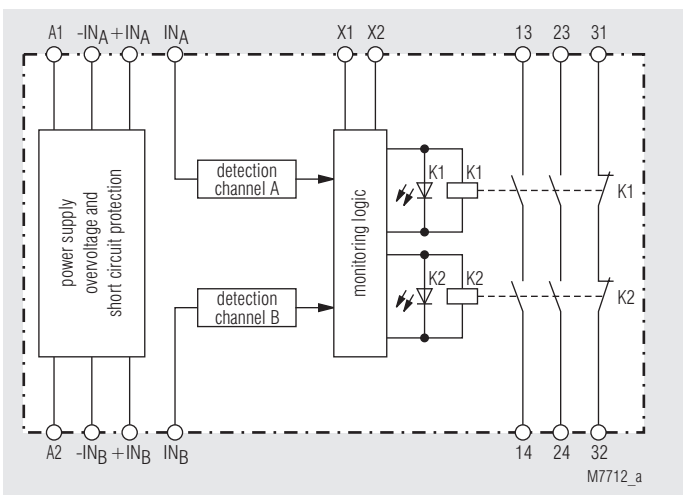

### Circuit Diagram

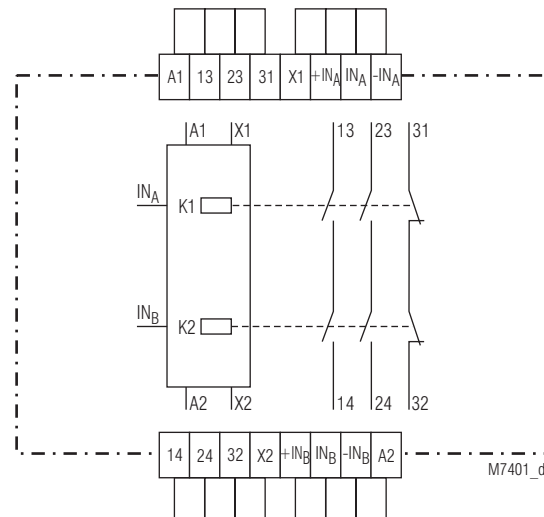

The device can be used for standstill and speed monitoring. All units have 2 sensing channels.

**Variants**

Three main variants are available:  
 BH 5932.22/\_ \_0: Devices with fixed tripping value  
 BH 5932.22/\_ \_2: Devices with separate adjustment for both channels  
 BH 5932.22/\_ \_1: Devices with common adjustment for both channels  
 BH 5932.22/\_ \_3: Devices with common adjustment for both channels and fine tuning to synchronise both channels

**Setting ranges**

On adjustable units the total range is split up in 4 sub ranges that can be selected with 2 DIP-switches per channel. To adjust the setting value in the selected range the potentiometers are used.

**Adjustment of setting range**

The number of pulses [rpm] to be adjusted can be calculated using the following formula:

$$\text{Rpm} \times \text{number of sensing spots} = \text{lpm}$$

e.g. 7.5 Rpm x 2 sensing spots = 15 lpm

**Operation as standstill monitor**

Both channels must be adjusted so that they switch simultaneously. The maximum time after standstill detection until switching of the output relays is depending on the adjusted lpm value. This delay can be calculated as follows:

$$\frac{60 \text{ s}}{\text{adjusted lpm-value}} + 2.5 \text{ s} = t_{vs}$$

$t_{vs}$  = operate delay after standstill detection

e.g. at a setting of 15 lpm

$$\frac{60 \text{ s}}{15} + 2.5 \text{ s} = 6.5 \text{ s}$$

**Operation as overspeed monitor**

Especially on overspeed monitoring it is necessary to adjust both channels precisely on simultaneous switching. If the two channels switch not at the same time the disconnection of the drive is only made with the faster channel. The speed can drop immediately so that the slower channel does not detect overspeed and remains switched on. A new start is then disabled and the relay does not switch on again. A restart is only possible by disconnecting the power supply. To achieve an accurate setting the lpm setting value should be in the middle part of the setting range. The adjustment of simultaneous switching is easier on units with separate setting for each channel as on units with fine tuning potentiometer.

**Proximity sensors**

For safe operation the proximity sensors should be mounted vibration free. The position of the sensors should be chosen in a way that both sensors are operated simultaneously. Care must be taken that the sensors do not influence each other. The connection of the sensors to the supply is monitored. If there is an interruption in the sensor supply the corresponding output relay cannot be switched on, or if it is already on, it will switch off immediately. To achieve a fault free operation, the sensor must have draw at least 3 mA in off state. If sensors with lower consumption are used only devices without sensor detection can be operated. According to EN ISO 13849-1, the sensors must be checked for correct function in reasonable time intervals.

**Feedback circuit, reset, LEDs and timing**

The reset circuit X1 - X2 must be closed before connecting the power supply. The unit is ready for operation after typically 1.5 sec after the supply is connected.

The LEDs channel 1 and channel 2 are on when the corresponding relay is energized. The output contacts of the relays will only be activated if both input channels reach the enabling condition within a time span of approx. 2 sec. If the response value is not reached on both channels within this time, e.g. because of a defective sensor or because the sensors do not simultaneously switch the output contacts are not enabled.

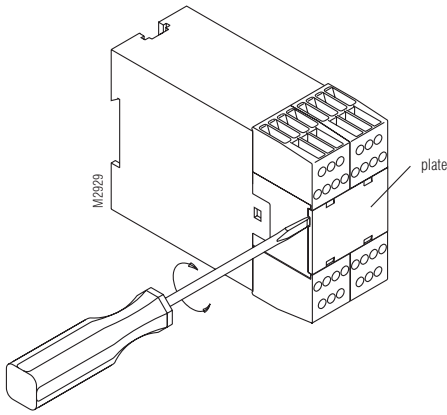

Model with separate adjustable channels

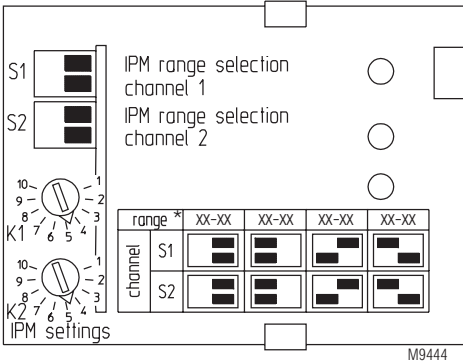

range\* : 8-60 / 60-450 / 450-3600 / 1800-14000 lpm  
 or 20-110 / 120-900 / 950-7000 / 3700-26000 lpm

Only operate switches while unit is disconnected

Model with common setting for both input channels

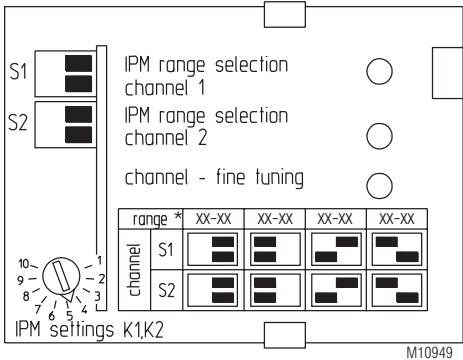

range\* : 8-60 / 60-450 / 450-3600 / 1800-14000 lpm  
 or 7-90 / 60-700 / 470-5500 / 1800-21000 lpm

Only operate switches while unit is disconnected

Model with common setting for both input channels and fine tuning to synchronise both channels

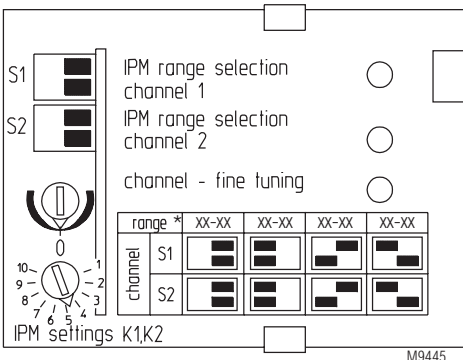

range\* : 5-40 / 35-340 / 300-2700 / 1200-10500 lpm  
 or 10-80 / 80-650 / 600-5300 / 2400-20000 lpm

Only operate switches while unit is disconnected

## Technical Data

### Input

<b>Nominal voltage <math>U_N</math>:</b>	AC/DC 24 V AC 110, 230 V
<b>Voltage range</b>	
AC:	0.85 ... 1.1 $U_N$
DC:	0.9 ... 1.1 $U_N$
<b>Nominal consumption:</b>	approx. 4 VA, 2.5 W
<b>Nominal frequency</b>	50 / 60 Hz
<b>Frequency range:</b>	45 ... 65 Hz
<b>Start up reset time <math>t_{Res}</math>:</b>	1.5 s
<b>Hysteresis:</b>	typ. 6 %

### Inputs for NPN- or optional PNP Proximity Sensors

<b>Input voltage:</b>	DC 24 V
<b>Input current:</b>	max. 25 mA (per channel)
<b>Min. current of sensor</b>	3 mA
<b>Min. pulse time:</b>	1 ms On, 1 ms Off
<b>Max. lpm at inputs</b>	
<b><math>IN_A</math> und <math>IN_B</math>:</b>	30000 lpm

### Speed Ranges [lpm]

#### Devices with fixed tripping value

BH 5932.22/_ _0:	15 / 30 / 60 / 120 lpm, fixed others on request (the output contacts close, when the speed is under the fixed lpm values)
Operate delay at standstill:	see formula
Release delay on overspeed:	$t_{aus}$ = typ. 700 ms

#### Devices with separate adjustment for both channels

BH 5932.22/_ _2	
Range 8 ... 14000 lpm:	adjustable in 4 subranges 8 ... 60, 60 ... 450, 450 ... 3600, 1800 ... 14000 lpm
or	
range 20 ... 26000 lpm:	adjustable in 4 subranges 20 ... 110, 120 ... 900, 950 ... 7000, 3700 ... 26000 lpm
Operate delay at standstill:	see formula
Release delay on overspeed	
Range 8 ... 14000:	$t_{off}$ = typ. 700 ms
Range 20 ... 26000:	$t_{off}$ = typ. 350 ms

#### Devices with common adjustment for both channels

BH 5932.22/_ _1	
Range 8 ... 14000 lpm:	adjustable in 4 subranges 8 ... 60, 60 ... 450, 450 ... 3600, 1800 ... 14000 lpm oder
Range 7 ... 21000 lpm:	adjustable in 4 subranges 7 ... 90, 60 ... 700, 470 ... 5500, 1800 ... 21000 lpm
Operate delay at standstill:	see formula
Release delay on overspeed	
Range 8 ... 14000:	$t_{aus}$ = typ. 700 ms
Range 7 ... 21000:	$t_{aus}$ = typ. 350 ms

#### Devices with common adjustment for both channels and fine tuning to synchronise both channels

BH 5932.22/_ _3	
Range 5 ... 10500 lpm:	adjustable in 4 subranges 5 ... 40, 35 ... 340, 300 ... 2700, 1200 ... 10500 lpm
or	
range 10 ... 20000 lpm:	adjustable in 4 subranges 10 ... 80, 80 ... 650, 600 ... 5300, 2400 ... 20000 lpm
Operate delay at standstill:	see formula
Release delay on overspeed	
Range 5 ... 10500:	$t_{off}$ = typ. 700 ms
Range 10 ... 20000:	$t_{off}$ = typ. 350 ms

## Technical Data

### Output

<b>Contacts:</b>	2 NO, 1 NC
<b>Contact type:</b>	forcibly guided
<b>Thermal current <math>I_{th}</math>:</b>	4 A
<b>Switching current:</b>	AC: 8 A $\cos \varphi$ 1 ... 0.7
<b>Switching capacity</b>	
to AC 15	
NO contact:	3 A / AC 230 V IEC/EN 60 947-5-1
NC contact:	2 A / AC 230 V IEC/EN 60 947-5-1
nach DC 13	
NO contact:	1 A / DC 24 V IEC/EN 60 947-5-1
NC contact:	1 A / DC 24 V IEC/EN 60 947-5-1
according to DC 13	
NO contact:	4 A / DC 24 V at 0.1 Hz
NC contact:	4 A / DC 24 V at 0.1 Hz
<b>Elektrical life</b>	IEC/EN 60 947-5-1
to AC 15 at 2 A, AC 230 V:	$\geq 3 \times 10^5$ switching cycles
<b>Short-circuit strength</b>	
<b>max. fuse rating:</b>	4 A gL IEC/EN 60 947-5-1
<b>Mechanical life:</b>	$\geq 50 \times 10^6$ switching cycles

### General Data

<b>Operating mode:</b>	Continuous operation
<b>Temperature range</b>	
operation:	- 25 ... + 60 °C
storage :	- 25 ... + 85 °C
<b>altitude:</b>	< 2.000 m
<b>Clearance and creepage distances</b>	
rated impuls voltage /	
pollution degree	IEC 60 664-1
Input / output	4 kV / 2
<b>EMC</b>	
Electrostatic discharge:	8 kV (Air) IEC/EN 61 000-4-2
HF irradiation:	10 V/m IEC/EN 61 000-4-3
Fast transients:	2 kV IEC/EN 61 000-4-4
Surge voltages	
between	
wires for power supply:	1 kV IEC/EN 61 000-4-5
between wire and ground:	2 kV IEC/EN 61 000-4-5
HF-wire guided:	10 V IEC/EN 61 000-4-6
Interference suppression:	Limit class B EN 55 011 at AC 24 V limit class A
<b>Degree of protection</b>	
Housing:	IP 40 IEC/EN 60 529
Terminals:	IP 20 IEC/EN 60 529
<b>Housing:</b>	Thermoplastic with V0 behaviour according to UL subject 94
<b>Vibration resistance:</b>	Amplitude 0.35 mm frequency 10 ... 55 Hz IEC/EN 60 068-2-6 20 / 060 / 04 IEC/EN 60 068-1
<b>Climate resistance:</b>	EN 50 005
<b>Terminal designation:</b>	
<b>Wire connection:</b>	1 x 4 mm <sup>2</sup> solid or 1 x 2.5 mm <sup>2</sup> stranded ferruled (isolated) or 2 x 1.5 mm <sup>2</sup> stranded ferruled (isolated) DIN 46 228-1/-2/-3/-4 or 2 x 2.5 mm <sup>2</sup> stranded ferruled DIN 46 228-1/-2/-3
<b>Wire fixing:</b>	Plus-minus terminal screws M3.5 box terminals with wire protection
<b>Mounting:</b>	DIN rail IEC/EN 60 715
<b>Weight:</b>	410 g
<b>Dimensions</b>	
<b>Width x height x depth:</b>	45 x 85 x 121 mm

## Technical Data

### Safety Related Data

#### Values according to EN ISO 13849-1:

Kategorie:	3	
PL:	e	
MTTF <sub>d</sub> :	280.3	a (year)
DC / DC <sub>avg</sub> :	99.0	%
d <sub>op</sub> :	365	d/a (days/year)
h <sub>op</sub> :	24	h/d (hours/day)
t <sub>Zyklus</sub> :	3600	s/Zyklus
	≅ 1	/h (hour)

#### Values according to IEC/EN 62061 / IEC/EN 61508 / IEC/EN 61511:

SIL CL:	3	IEC/EN 62061
SIL:	3	IEC/EN 61508 / IEC/EN 61511
HFT:	1	
DC / DC <sub>avg</sub> :	99.0	%
SFF:	99.7	%
PFH <sub>D</sub> :	1.74E-10	h <sup>-1</sup>
PFD:	1.49E-05	
T <sub>f</sub> :	20	a (year)

<sup>1)</sup> HFT = Hardware-Failure-Tolerance

**Info** The values stated above are valid for the standard type. Safety data for other variants are available on request. The safety relevant data of the complete system has to be determined by the manufacturer of the system.

### UL-Data

The safety functions were not evaluated by UL. Listing is accomplished according to requirements of Standard UL 508, "general use applications"

#### Switching capacity:

Ambient temperature 60°C:	Pilot duty B300
	4A 250Vac G.P.
	4A 24Vdc

#### Wire connection:

60°C / 75°C copper conductors only
AWG 20 - 12 Sol Torque 0.8 Nm
AWG 20 - 14 Str Torque 0.8 Nm

**Info** Technical data that is not stated in the UL-Data, can be found in the technical data section.

### Standard Type

BH 5932.22/112	AC/DC 24 V	20 ... 26000 lpm
Article number:		0059482
BH 5932.22/112	AC/DC 24 V	8 ... 14000 lpm
Article number:		0059478
• Output:		2 NO, 1 NC contacts
• Nominal voltage U <sub>N</sub> :		DC 24 V
• Input:		for pnp-sensors and with sensor detection
• Width:		45 mm

## Variants

BH 5932.22/\_/\_/61: with UL-approval (Canada/USA)

### Ordering example for variants

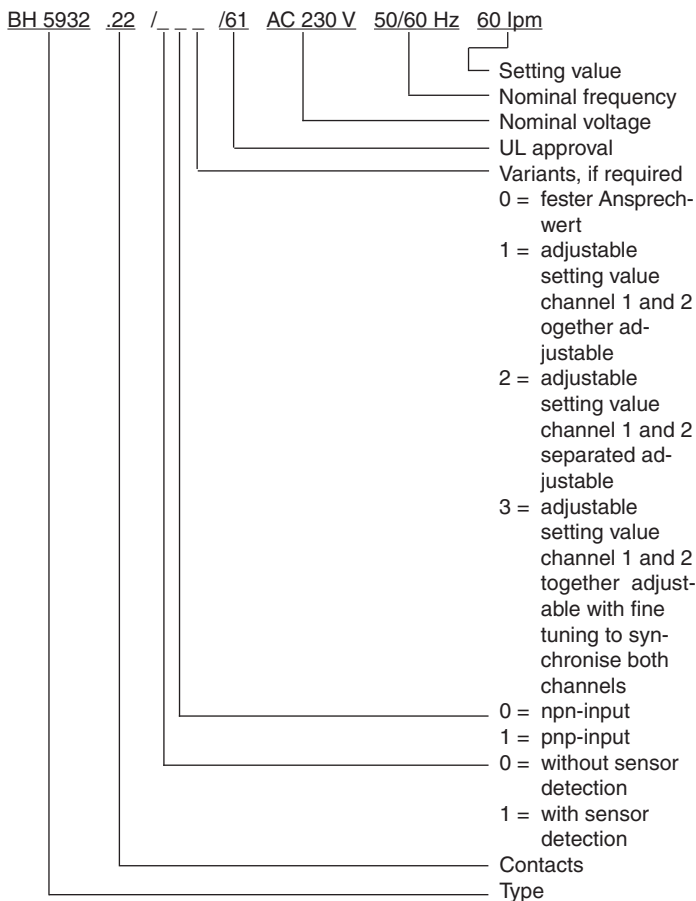

### Connection Examples

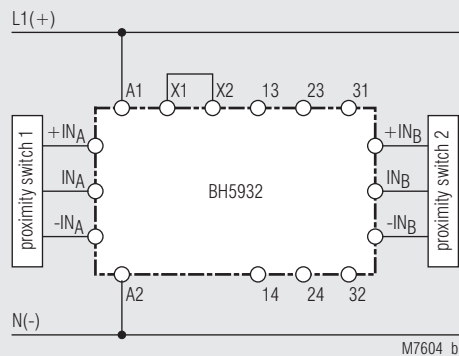

Standard connection  
suited up to SIL3, Performance Level e, Cat. 4

## Connection Examples

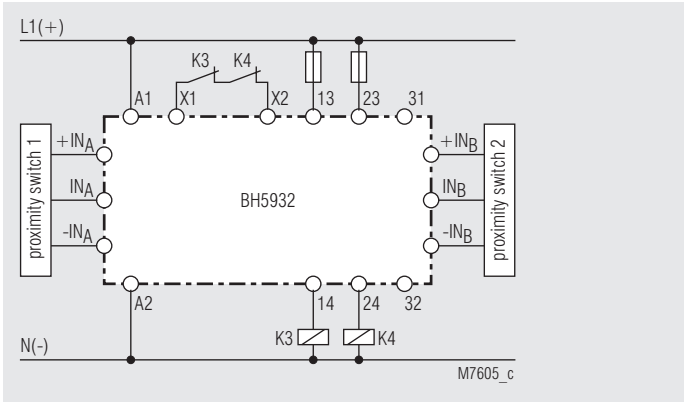

Connection with external contactors, suited up to SIL3, Performance Level e, Cat. 4

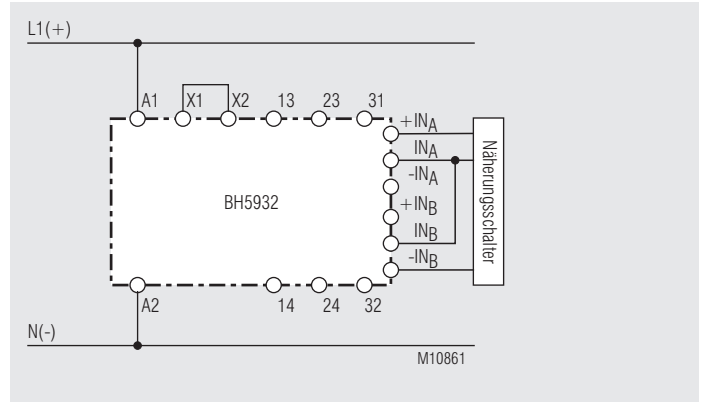

Connection with proximity sensors suited up to SIL3, Performance Level e, Cat. 4 (to achieve Cat. 2 the safety function has to be tested on a regular base.)

## Application Example

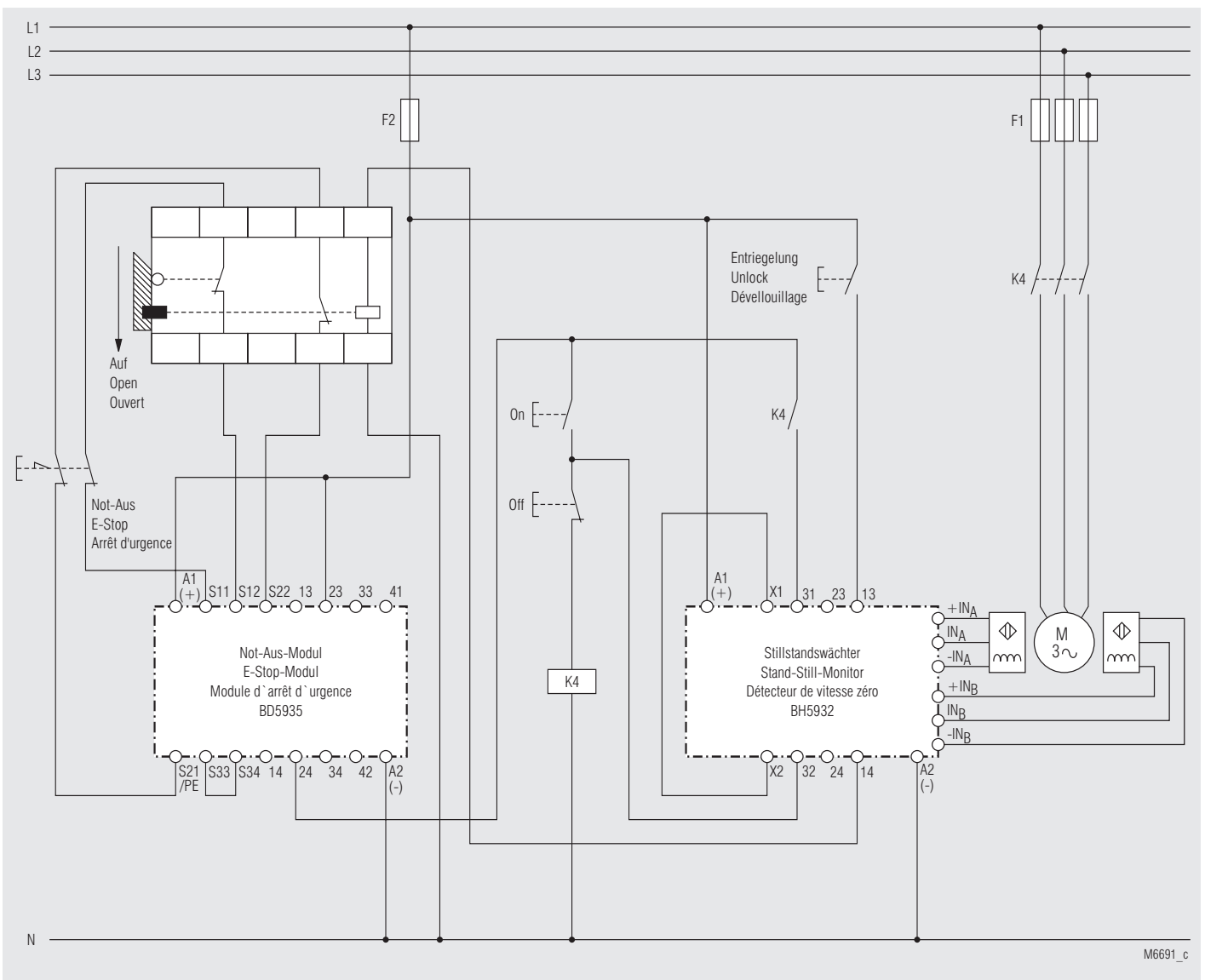

**Initiators (proximity sensors), induktive**

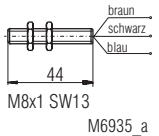
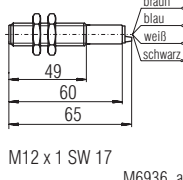
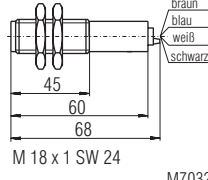
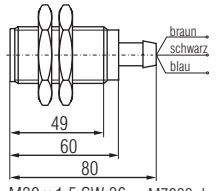
Type	NA 5001.01.10 pnp NA 5001.01.20 npn	NA 5002.01.34 pnp/npn	NA 5005.01.34 pnp/npn	NA 5010.01.10 pnp NA 5010.01.20 npn
Dimensions				
Enclosure	Metal	Metal	Metal	Metal
Switching distance $S_n$	1 mm	2 mm	5 mm	10 mm
Switching frequency	5 000 Hz	1 000 Hz	300 Hz	200 Hz
Hysteresis	2 ... 10 %			
Repeat accuracy	5 %			
Voltage range	10 ... 30 V			
Residual ripple	< 10 %			
Continuous current	≤ 200 mA	≤ 100 mA	≤ 100 mA	≤ 400 mA
Output	.10 pnp NO .20 npn NO	.34 pnp NO + npn NO	.34 pnp NO + npn NO	.10 pnp NO .20 npn NO
Indication of output state	LED			
Ambient temperature	- 25 ... 70°C			
Temperature influence	10 %			
Degree of protection	IP 67			
Connection wire	2 m			
Fixing torque	4 Nm	15 Nm	40 Nm	100 Nm
Weight	45 g	70 g	120 g	270 g

**Connection Table BH 5932, BH 5932 / 00\_**

Type	Wire	Terminal on BH 5932
NA 5001.01.20	brown +	+ $I_{n_A}$ / + $I_{n_B}$
	blue -	- $I_{n_A}$ / - $I_{n_B}$
	black NO	$I_{n_A}$ / $I_{n_B}$
NA 5002.01.34 NA 5005.01.34	brown +	+ $I_{n_A}$ / + $I_{n_B}$
	blanc NO	$I_{n_A}$ / $I_{n_B}$
	blue -	- $I_{n_A}$ / - $I_{n_B}$
	black -	- $I_{n_A}$ / - $I_{n_B}$
NA 5010.01.20	brown +	+ $I_{n_A}$ / + $I_{n_B}$
	blue -	- $I_{n_A}$ / - $I_{n_B}$
	black NO	$I_{n_A}$ / $I_{n_B}$

**Connection Table BH 5932, BH 5932 / 01\_**

Type	Wire	Terminal on BH 5932
NA 5001.01.10	brown +	+ $I_{n_A}$ / + $I_{n_B}$
	blue -	- $I_{n_A}$ / - $I_{n_B}$
	black NO	$I_{n_A}$ / $I_{n_B}$
NA 5002.01.34 NA 5005.01.34	brown +	+ $I_{n_A}$ / + $I_{n_B}$
	blanc +	+ $I_{n_A}$ / + $I_{n_B}$
	blue -	- $I_{n_A}$ / - $I_{n_B}$
	black NO	$I_{n_A}$ / $I_{n_B}$
NA 5010.01.10	brown +	+ $I_{n_A}$ / + $I_{n_B}$
	blue -	- $I_{n_A}$ / - $I_{n_B}$
	black NO	$I_{n_A}$ / $I_{n_B}$

**ATTENTION!**

Only the initiators NA5001.01.10, NA5001.01.20, NA5010.01.10 and NA5010.01.20 are usable for units with initiator-detection (BH 5932.22/1xx) !

# Mouser Electronics

Authorized Distributor

Click to View Pricing, Inventory, Delivery & Lifecycle Information:

[Altech:](#)

[DOLD 62619](#)



Компания «ЭлектроПласт» предлагает заключение долгосрочных отношений при поставках импортных электронных компонентов на взаимовыгодных условиях!

Наши преимущества:

- Оперативные поставки широкого спектра электронных компонентов отечественного и импортного производства напрямую от производителей и с крупнейших мировых складов;
- Поставка более 17-ти миллионов наименований электронных компонентов;
- Поставка сложных, дефицитных, либо снятых с производства позиций;
- Оперативные сроки поставки под заказ (от 5 рабочих дней);
- Экспресс доставка в любую точку России;
- Техническая поддержка проекта, помощь в подборе аналогов, поставка прототипов;
- Система менеджмента качества сертифицирована по Международному стандарту ISO 9001;
- Лицензия ФСБ на осуществление работ с использованием сведений, составляющих государственную тайну;
- Поставка специализированных компонентов (Xilinx, Altera, Analog Devices, Intersil, Interpoint, Microsemi, Aeroflex, Peregrine, Syfer, Eurofarad, Texas Instrument, Miteq, Cobham, E2V, MA-COM, Hittite, Mini-Circuits, General Dynamics и др.);

Помимо этого, одним из направлений компании «ЭлектроПласт» является направление «Источники питания». Мы предлагаем Вам помощь Конструкторского отдела:

- Подбор оптимального решения, техническое обоснование при выборе компонента;
- Подбор аналогов;
- Консультации по применению компонента;
- Поставка образцов и прототипов;
- Техническая поддержка проекта;
- Защита от снятия компонента с производства.



#### Как с нами связаться

**Телефон:** 8 (812) 309 58 32 (многоканальный)

**Факс:** 8 (812) 320-02-42

**Электронная почта:** [org@eplast1.ru](mailto:org@eplast1.ru)

**Адрес:** 198099, г. Санкт-Петербург, ул. Калинина, дом 2, корпус 4, литера А.