



NB7NPQ7021MMUGEVB Evaluation Board User's Manual

Introduction

The NB7NPQ7021MMUGEVB evaluation board was developed to provide a convenient platform to quickly verify the operation of the NB7NPQ7021M redriver in a USB type-C system environment.

This evaluation board manual contains:

- Information on the NB7NPQ7021M Evaluation Board
- Board Schematics
- Bill of Materials

Demo Board

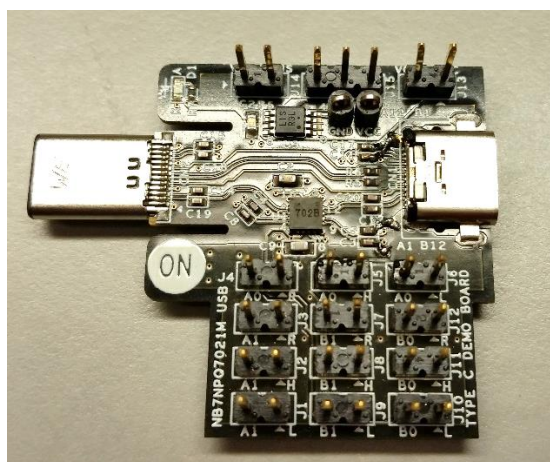

Figure 1. Kit Contents

Board Features

- Accommodates the Functional Evaluation of the NB7NPQ7021M
- Acts as a Reference Design that Can Easily be Modified for Active Cables, UFP (Upstream Facing Port), DFP (Downstream Facing Port), and DRP (Dual Role Port) Applications
- Type-C Plug and Receptacle to Easily Place in the Existing System Environment
- On Board Control Pins for Adjusting Settings without Compromising Form Factor
- Two NB7NPQ7021M devices to facilitate USB Type-C connections without using a multiplexor.

Part Description

The NB7NPQ7021M is a 3.3 V dual channel, linear redriver for USB 3.1 applications that supports both 5 and 10 Gbps data rates. Signal integrity degrades from PCB traces and transmission cables which may cause inter-symbol interference (ISI). The NB7NPQ7021M compensates for these losses by engaging varying levels of equalization at the input receiver. The output transmitter circuitry provides user selectable flat gain settings to create the best eye openings for the outgoing data signals. The flexibility of this part allows it to fit into many system applications.

After power up, the NB7NPQ7021M periodically checks both of the TX output pairs for a SuperSpeed USB receiver. When the receiver is detected, the RX termination becomes enabled and the NB7NPQ7021M is set to perform the redriver function.

The NB7NPQ7021M comes in a small 3 mm x 3 mm UQFN-16 package and is specified to operate across the entire industrial temperature range, -40°C to 85°C.

This manual should be used in conjunction with the device datasheet which contains full technical details on the device specifications and operation.

NB7NPQ7021MMUGAEVB

BOARD MAP AND FUNCTIONAL SUMMARY

VCC and GND pins:
These pins can be used to measure the power going to the NB7NPQ7021M devices. They can also be used to power the NB7NPQ7021M directly with a 3.3V supply and to measure the current through the device.

Jumper "J14":
This jumper connects the 5V USB bus voltage to the input of a 3.3V LDO.

Jumper "J15":
This jumper can pull the enable pin of the 3.3V LDO to different voltage levels. This should be left open at all times.

Jumper "J13":
This jumper connects the 3.3V output of the LDO to the VCC pins of the 2, NB7NPQ7021M Devices on the board.

Resistors "R5 and R6":
These are 0Ω resistors that connect the USB 2.0 data lines. These can be removed in order to guarantee that only the super speed data lines are active.

EQ and Flat Gain Control pin Jumpers :
These control the EQ and FG settings. Each 4-level control pin can be set to "H", Floating, "R", or "L".

Jumpers are provided for CTRL_A0, CTRL_A1, CTRL_B0, and CTRL_B1.

*Please see the data sheet for the table of settings and corresponding EQ and FG.

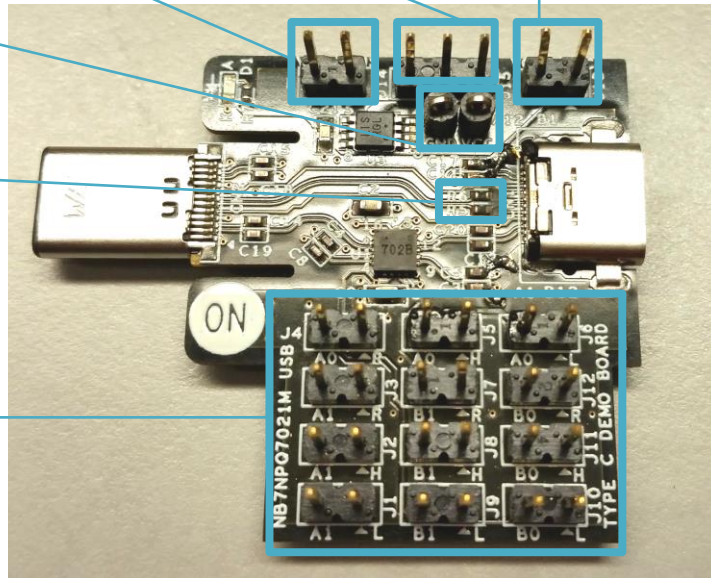

Figure 2. NB7NPQ7021M Evaluation Board Important connection information

NB7NPQ7021MMUGAEVB

External Power Supply Instructions

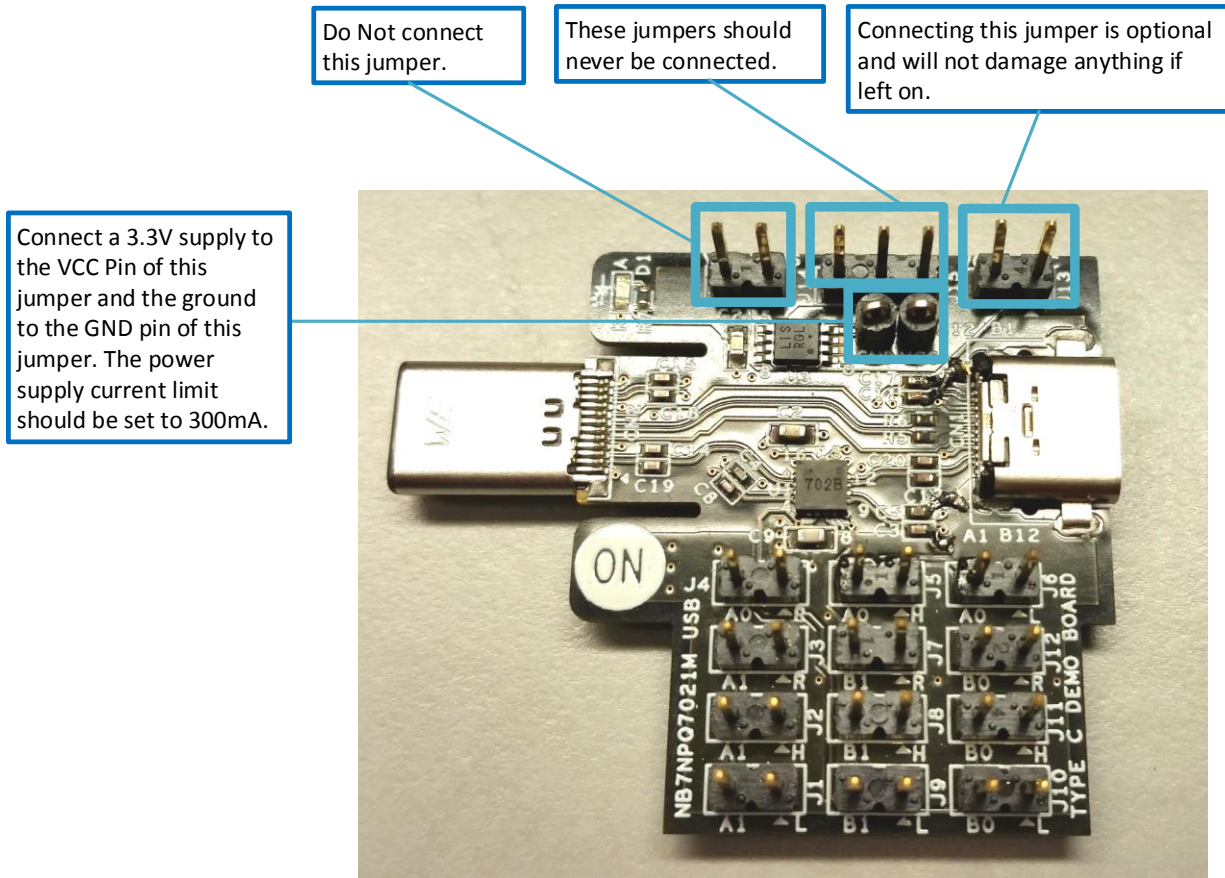

Figure 3. NB7NPQ7021M Evaluation Board – Connecting to an External Power Supply

NB7NPQ7021MMUGAEVB

Select Power Source

The NB7NPQ7021MMUGAEVB has the flexibility to be powered through USB's VBUS, or an external power supply. Table 1 and Figure 3 describe the jumper settings for each of the configurations:

Monitoring Current / Power

There are two easy ways to monitor the current consumed by the redriver. If you are using an external power supply, you can simply use the current meter commonly found on the power supplies. If you would like to use a current probe, simply solder the probe between the VCC pin and the power supply. This will allow monitoring of the NB7PQ7021M's current consumption.

Step 4: USB 2.0 Data Lines

The USB 2.0 lines can be disconnected by removing the 0Ω resistors R5 and R6 on the D+ and D- lines. This is useful if you cannot easily tell whether the downstream facing port has acknowledged a super speed (+) connection with the inserted loss, or if it stepped down to high speed data rates. When a receiver is detected through RxDetect, the DFP will initialize link training. It will send a test signal out at the highest data rate and expect to see the same signal sent back

by the UFP. If the signals do not match due to ISI (or any other connection issues) then it will drop down the data rate to USB 2.0 speeds.

On Windows machines, an easy way to tell that a super speed connection was not established is to look for a pop-up in the task bar letting the user know that "This device can perform faster". A disk benchmarking tool like Crystal Disk Mark that lets you test read and write speeds to a peripheral storage can also be used.

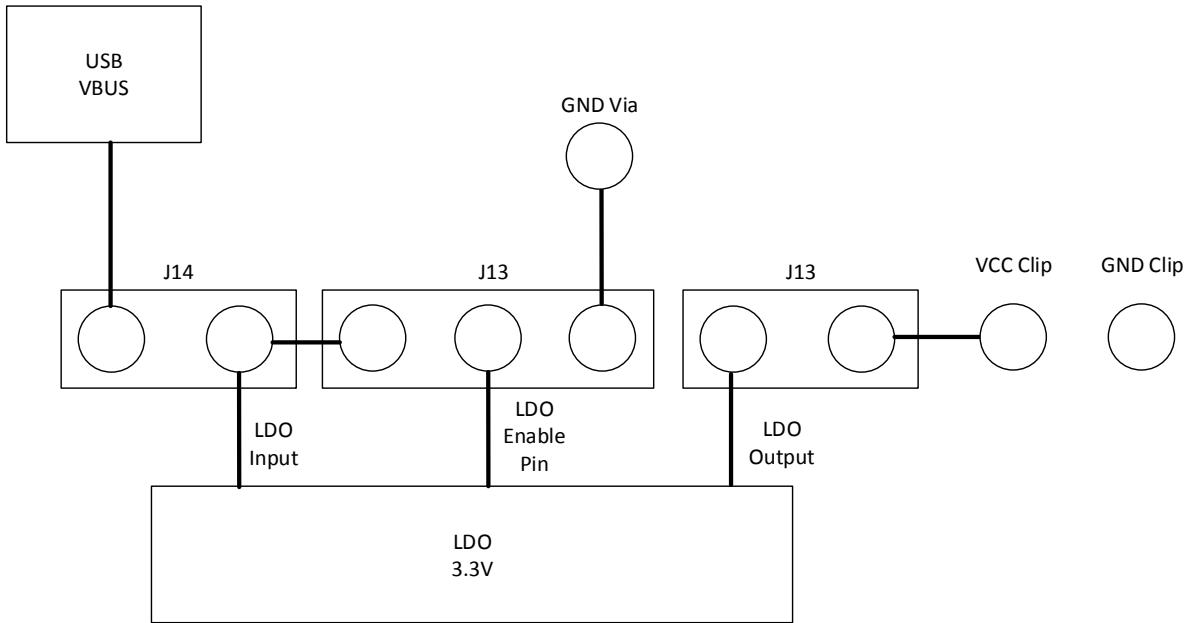
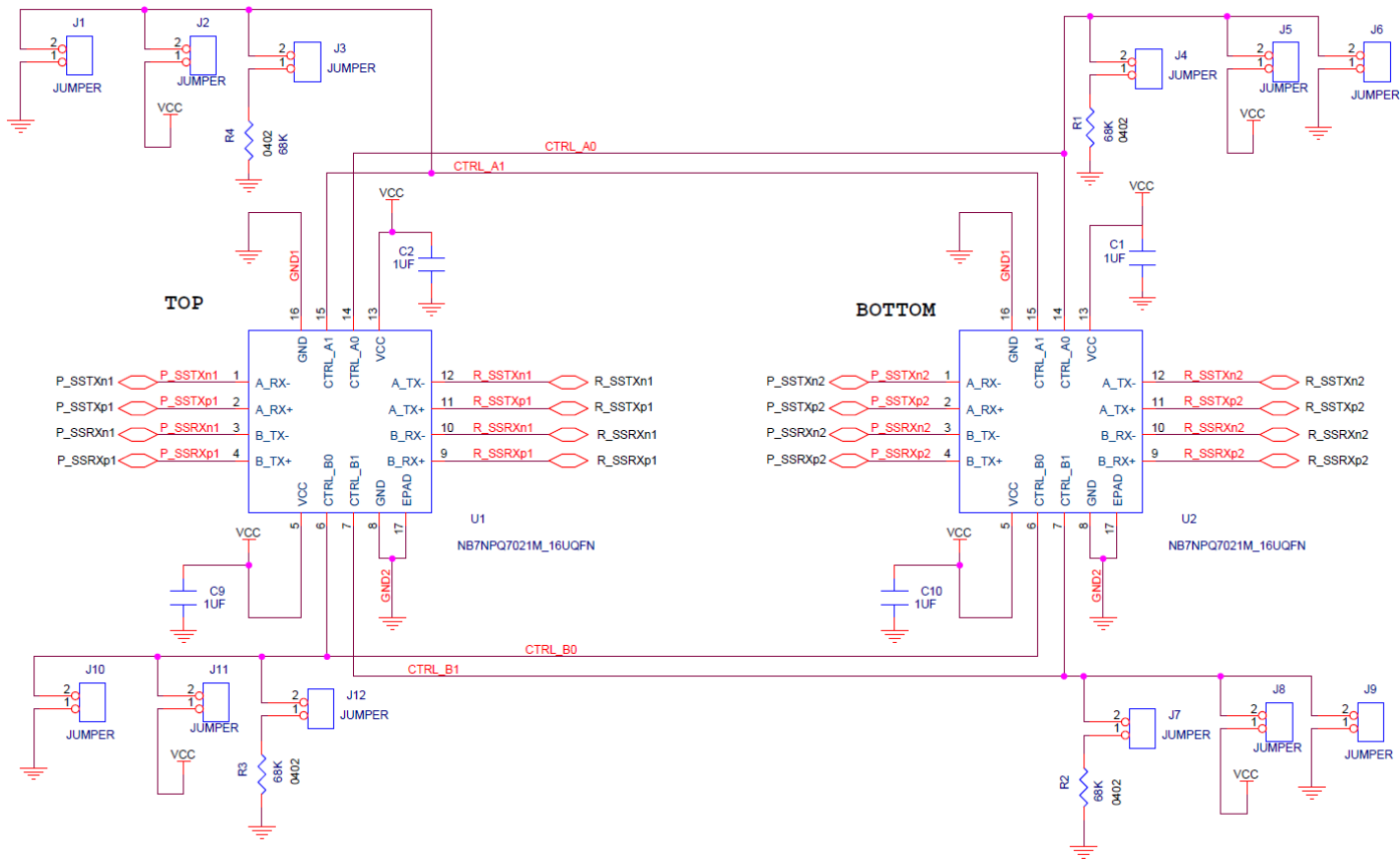

Figure 4. Power Source Selection

Table 1. Selecting a Power Source	
USB VBUS	Place jumper on J14 and a Jumper on J13
External Supply	Open J14 and connect positive lead of external supply to VCC clip and apply 3.3 V. Ensure that GND clip is connected to ground and that current limit is set to 300mA.

NB7NPQ7021MMUGAEVB

Complete Board Schematics



NB7NPQ7021MMUGAEVB

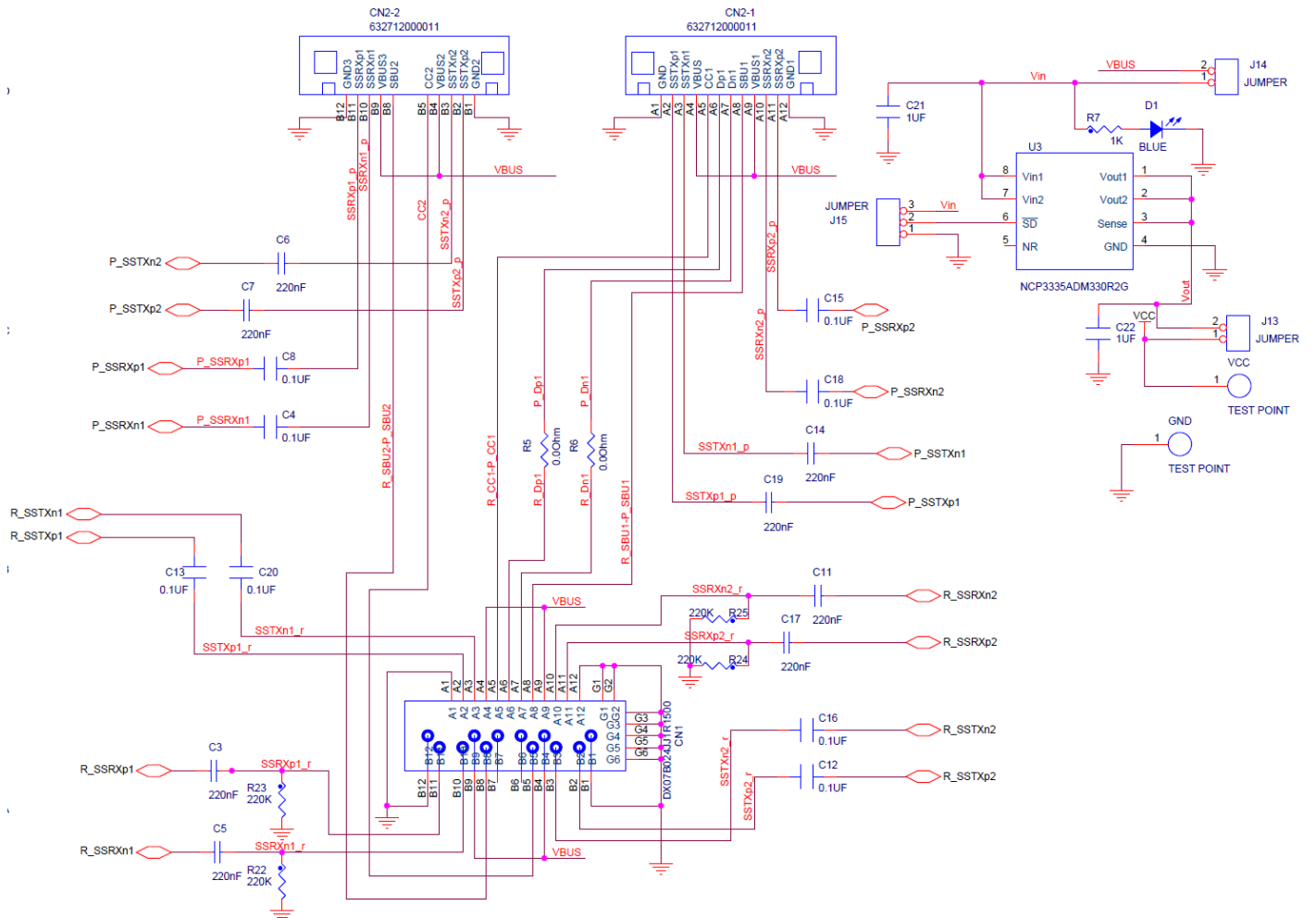



Figure 5. NB7NPQ7021M USB Type-A Evaluation Board Schematics

NB7NPQ7021MMUGAEVB

BILL OF MATERIAL

Table 2. BILL OF MATERIALS

Qty	Description	Schematic Reference	Manufacturer	Manufacturer Part Number
14	Header, 0.100"	J1;J2;J3;J4;J5;J6;J7;J8;J9; J10;J11;J12;J13;J14	FCI	77311-118-02LF
1	3 Cnt Header, 0.100"	J15	FCI	68001-203HLF
8	Capacitor 0.22uF (0402)	C3;C5;C6;C7;C11;C14;C17; C19	TDK	C1005X5R1C224M050BB
8	Capacitor 0.1uF (0402)	C4;C8;C12;C13;C15;C16; C18;C20	TDK	C1005X5R1E104K050BC
6	Capacitor 1uF (0603)	C1;C2;C9;C10;C21;C22	Samsung	CL10A105KA5LNNC
1	USB Type-C Receptacle	CN1	Mill-Max	898-73-024-90-310001
1	Blue LED	D1	Rohm	SMLE12BC7TT86
1	3.3V Voltage Regulator	U3	ON Semiconductor	NCP3335ADM330R2G
4	Resistor 68K Ohm (0402)	R1;R2;R3;R4	Panasonic	ERJ-2RKF6802X
2	Resistor 0.0 Ohm (0402)	R5;R6	Yageo	RC0402JR-070RL
1	Resistor 1K Ohm (0402)	R7	Panasonic	ERJ-2RKF1001X
1	USB Type-C Plug	CN2	Wurth Elektronik	632712000011
4	Resistor 220K Ohm (0402)	R22;R23;R24;R25	Panasonic	
2	Connector	GND;VCC		

ON Semiconductor and  are trademarks of Semiconductor Components Industries, LLC dba ON Semiconductor or its subsidiaries in the United States and/or other countries. ON Semiconductor owns the rights to a number of patents, trademarks, copyrights, trade secrets, and other intellectual property. A listing of ON Semiconductor's product/patent coverage may be accessed at www.onsemi.com/site/pdf/Patent-Marketing.pdf. ON Semiconductor reserves the right to make changes without further notice to any products herein. ON Semiconductor makes no warranty, representation or guarantee regarding the suitability of its products for any particular purpose, nor does ON Semiconductor assume any liability arising out of the application or use of any product or circuit, and specifically disclaims any and all liability, including without limitation special, consequential or incidental damages. Buyer is responsible for its products and applications using ON Semiconductor products, including compliance with all laws, regulations and safety requirements or standards, regardless of any support or applications information provided by ON Semiconductor. "Typical" parameters which may be provided in ON Semiconductor data sheets and/or specifications can and do vary in different applications and actual performance may vary over time. All operating parameters, including "Typicals" must be validated for each customer application by customer's technical experts. ON Semiconductor does not convey any license under its patent rights nor the rights of others. ON Semiconductor products are not designed, intended, or authorized for use as a critical component in life support systems or any FDA Class 3 medical devices or medical devices with a same or similar classification in a foreign jurisdiction or any devices intended for implantation in the human body. Should Buyer purchase or use ON Semiconductor products for any such unintended or unauthorized application, Buyer shall indemnify and hold ON Semiconductor and its officers, employees, subsidiaries, affiliates, and distributors harmless against all claims, costs, damages, and expenses, and reasonable attorney fees arising out of, directly or indirectly, any claim of personal injury or death associated with such unintended or unauthorized use, even if such claim alleges that ON Semiconductor was negligent regarding the design or manufacture of the part. ON Semiconductor is an Equal Opportunity/Affirmative Action Employer. This literature is subject to all applicable copyright laws and is not for resale in any manner.

PUBLICATION ORDERING INFORMATION

LITERATURE FULFILLMENT:

Literature Distribution Center for ON Semiconductor
 19521 E. 32nd Pkwy, Aurora, Colorado 80011 USA
Phone: 303-675-2175 or 800-344-3860 Toll Free USA/Canada
Fax: 303-675-2176 or 800-344-3867 Toll Free USA/Canada
Email: orderlit@onsemi.com
N. American Technical Support: 800-282-9855 Toll Free
ON Semiconductor Website: www.onsemi.com

USA/Canada
Europe, Middle East and Africa Technical Support:
 Phone: 421 33 790 2910
Japan Customer Focus Center
 Phone: 81-3-5817-1050

Order Literature: <http://www.onsemi.com/orderlit>

For additional information, please contact your local Sales Representative



Компания «ЭлектроПласт» предлагает заключение долгосрочных отношений при поставках импортных электронных компонентов на взаимовыгодных условиях!

Наши преимущества:

- Оперативные поставки широкого спектра электронных компонентов отечественного и импортного производства напрямую от производителей и с крупнейших мировых складов;
- Поставка более 17-ти миллионов наименований электронных компонентов;
- Поставка сложных, дефицитных, либо снятых с производства позиций;
- Оперативные сроки поставки под заказ (от 5 рабочих дней);
- Экспресс доставка в любую точку России;
- Техническая поддержка проекта, помощь в подборе аналогов, поставка прототипов;
- Система менеджмента качества сертифицирована по Международному стандарту ISO 9001;
- Лицензия ФСБ на осуществление работ с использованием сведений, составляющих государственную тайну;
- Поставка специализированных компонентов (Xilinx, Altera, Analog Devices, Intersil, Interpoint, Microsemi, Aeroflex, Peregrine, Syfer, Eurofarad, Texas Instrument, Miteq, Cobham, E2V, MA-COM, Hittite, Mini-Circuits, General Dynamics и др.);

Помимо этого, одним из направлений компании «ЭлектроПласт» является направление «Источники питания». Мы предлагаем Вам помощь Конструкторского отдела:

- Подбор оптимального решения, техническое обоснование при выборе компонента;
- Подбор аналогов;
- Консультации по применению компонента;
- Поставка образцов и прототипов;
- Техническая поддержка проекта;
- Защита от снятия компонента с производства.



Как с нами связаться

Телефон: 8 (812) 309 58 32 (многоканальный)

Факс: 8 (812) 320-02-42

Электронная почта: org@eplast1.ru

Адрес: 198099, г. Санкт-Петербург, ул. Калинина, дом 2, корпус 4, литера А.