

SPECIFICATION

FXP.810 2.4/4.9-6GHz Dual-band Antenna

Part No.	:	FXP.810.07.0100C
Product Name	:	FXP.810 Freedom Wi-Fi 2.4/4.9-6GHz Series PIFA Antenna
Feature	:	Very High Efficiency Ground-plane Independent IPEX MHF1 Connector (U.FL compatible) 1.37mm Diameter Micro Cable - 100 mm 31*31*0.1mm RoHS Compliant



1. Introduction

The FXP810 has a peak gain of 1.5dBi at 2.4GHz and efficiencies of 60-70%, increasing to 5dBi and 80-90% along bands 4.9GHz to 6GHz.

At 31*31*0.1mm in size this antenna is uniquely valuable for small tag type mobile devices in that it can slip between the battery and the main PCB ground of small devices to get increased performance from the ground coupling effect. Only the top 6.5mm radiating element needs to protrude out from the side of the main board, allowing such devices to have the highest possible performance at smallest possible dimensions, it accomplishes this because it does not need clearance or footprint space on the device board itself that all on-board chip, loop and patch antennas need.

Many module manufacturers specify peak gain limits for any antennas that are to be connected to that module. Those peak gain limits are based on free-space conditions. In practice, the peak gain of an antenna tested in free-space can degrade by at least 1 or 2dBi when put inside a device. So ideally you should go for a slightly higher peak gain antenna than mentioned on the module specification to compensate for this effect, giving you better performance.

Upon testing of any of our antennas with your device and a selection of appropriate layout, integration technique, or cable, Taoglas can make sure any of our antennas' peak gain will be below the peak gain limits. Taoglas can then issue a specification and/or report for the selected antenna in your device that will clearly show it complying with the peak gain limits, so you can be assured you are meeting regulatory requirements for that module.

For example, a module manufacturer may state that the antenna must have less than 2dBi peak gain, but you don't need to select an embedded antenna that has a peak gain of less than 2dBi in free-space. This will give you a less optimized solution. It is better to go for a slightly higher free-space peak gain of 3dBi or more if available. Once that antenna gets integrated into your device, performance will degrade below this

2dBi peak gain due to the effects of GND plane, surrounding components, and device housing. If you want to be absolutely sure, contact Taoglas and we will test. Choosing a Taoglas antenna with a higher peak gain than what is specified by the module manufacturer and enlisting our help will ensure you are getting the best performance possible without exceeding the peak gain limits.

2. Specification

ELECTRICAL		
Frequency	2.4 ~ 2.5GHz,	4.9 ~ 5.8GHz
Peak Gain (free space)	1.5dBi	5.1dBi
Peak Gain (on plastic*)	2.4dBi	5.0dBi
Average Gain (free space)	-2.6dBi	-1.1dBi
Average Gain (on plastic)	-1.2dBi	-0.8dBi
Efficiency (free space)	56%	78%
Efficiency (on plastic)	76%	84%
VSWR	≤1.7 : 1	
Impedance	50 Ohms	
Polarization	Linear	
Radiation Pattern	Omni	
Input Power	2W max.	
MECHANICAL		
Dimensions	31mm*31mm*0.1mm	
Antenna Body Material	Polymer	
Cable	Gray 100mm 1.37 co-axial	
Connector	IPEX MHFI	
ENVIRONMENTAL		
Temperature Range	-40°C to 85°C	
Humidity	Non-condensing 65°C 95% RH	

* On ABS Plastic 4mm

3. Electrical Property

3.1 S11 Measurement

Free Space:

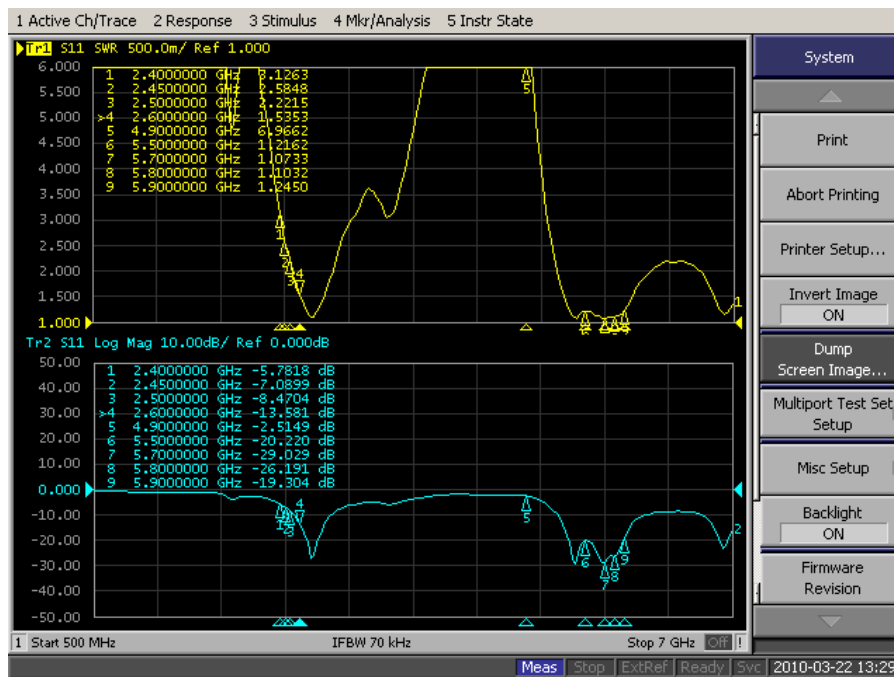

Plastic 1.5mm:

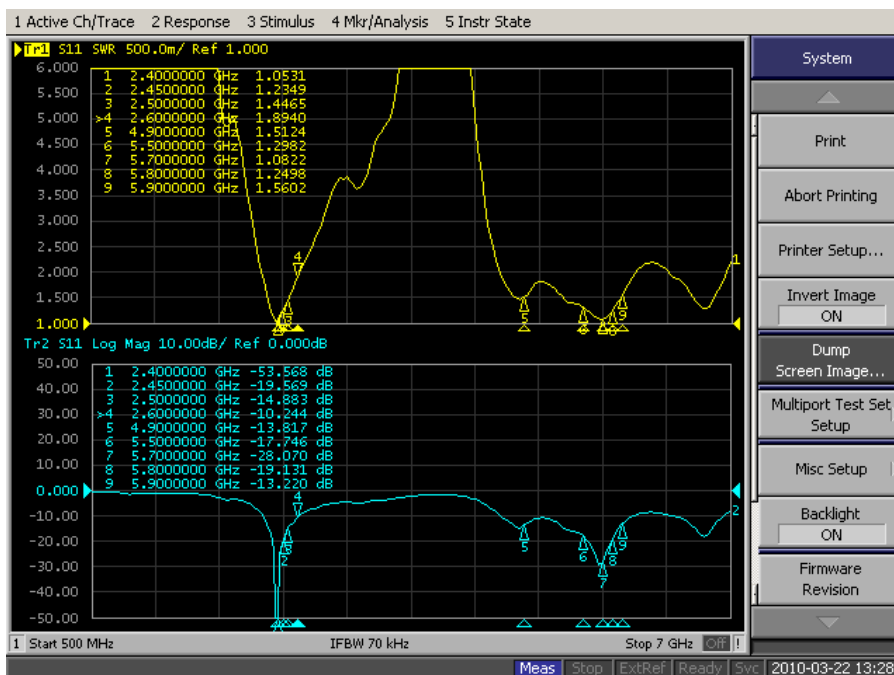

3.2 Efficiency

FXP. 810

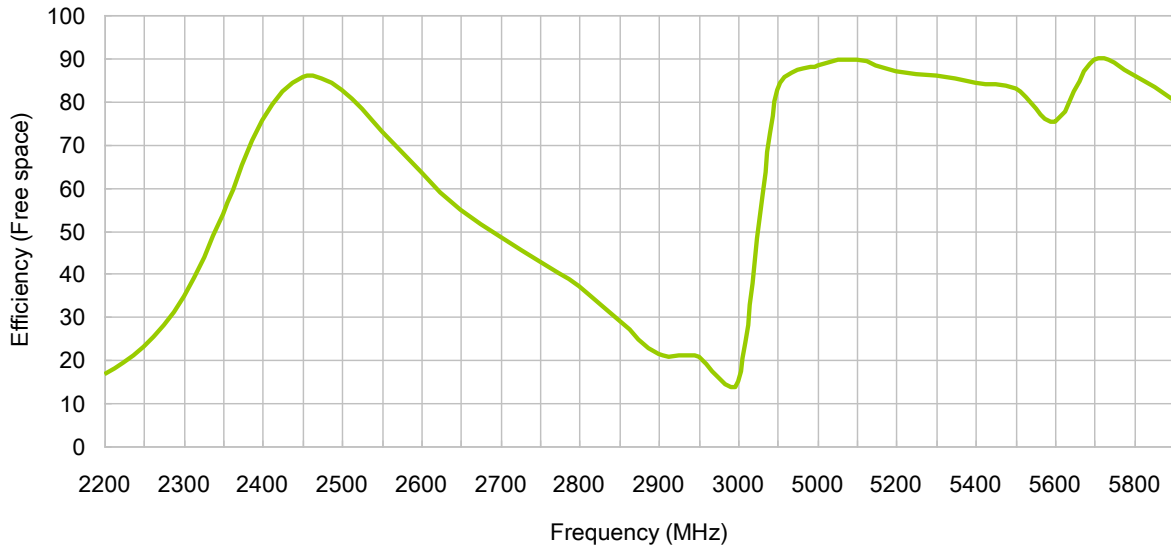

3.3 Gain

FXP. 810

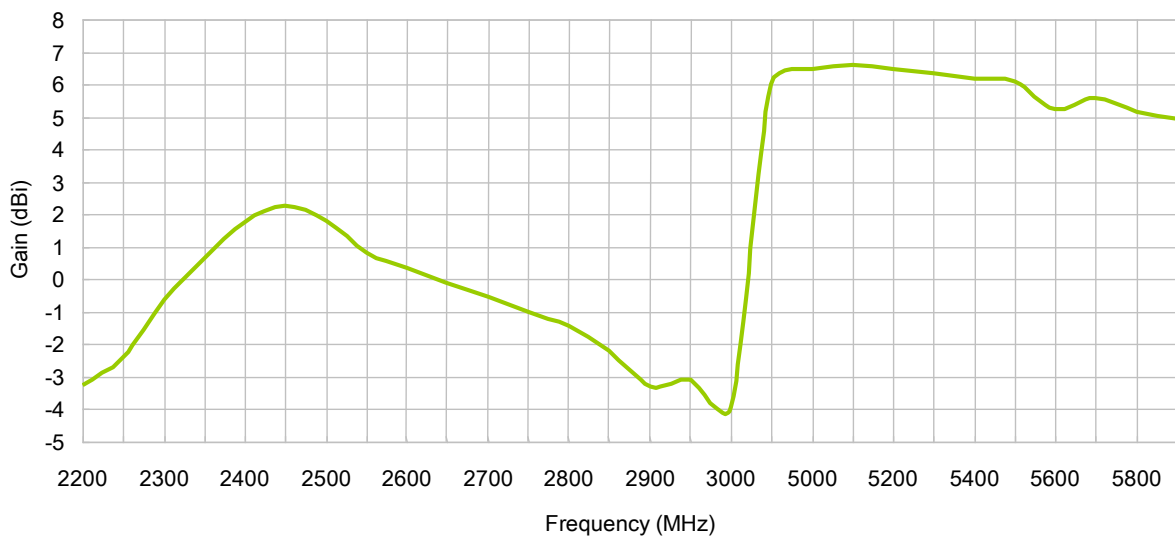

3.4 Radiation Pattern

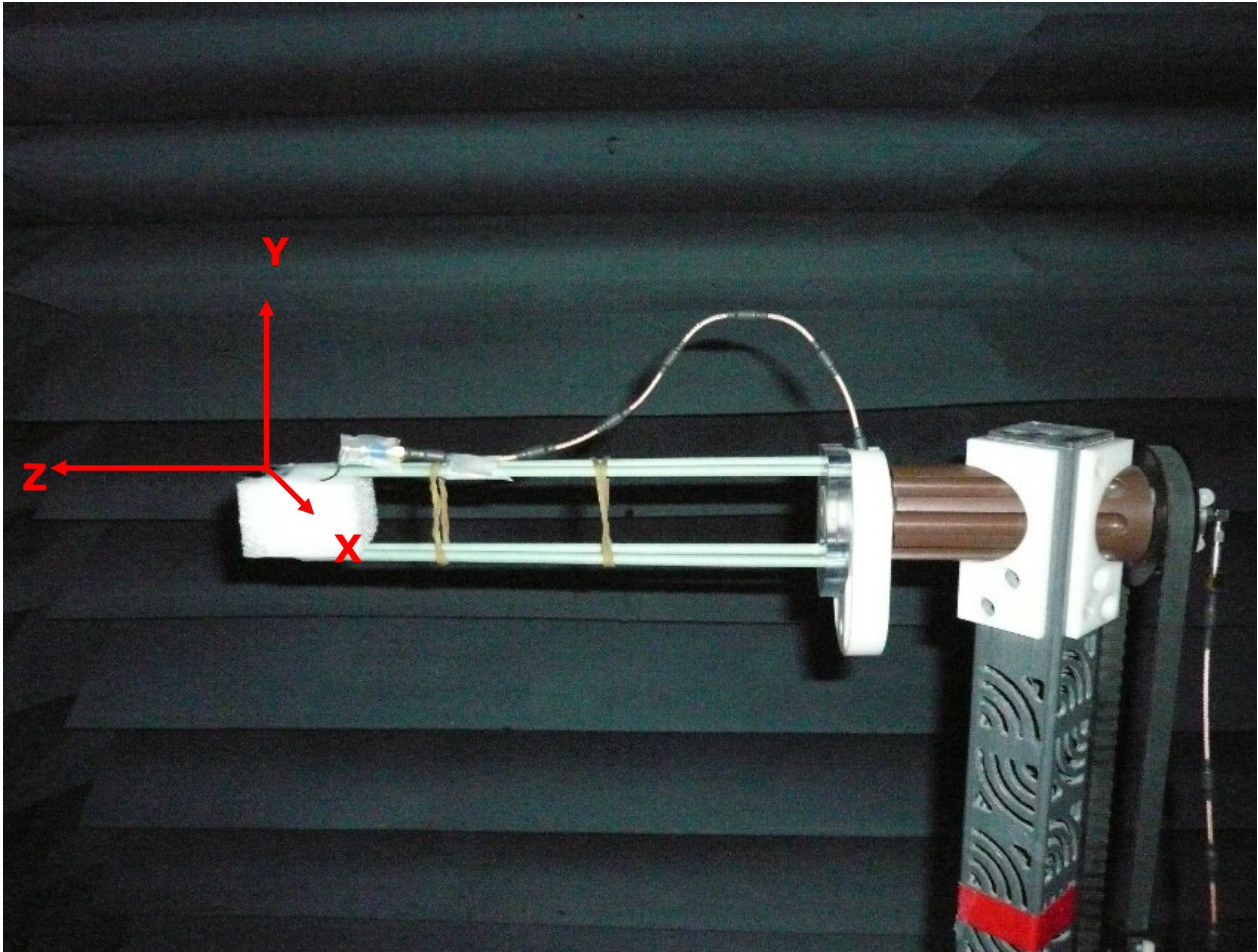

2450MHz Pattern

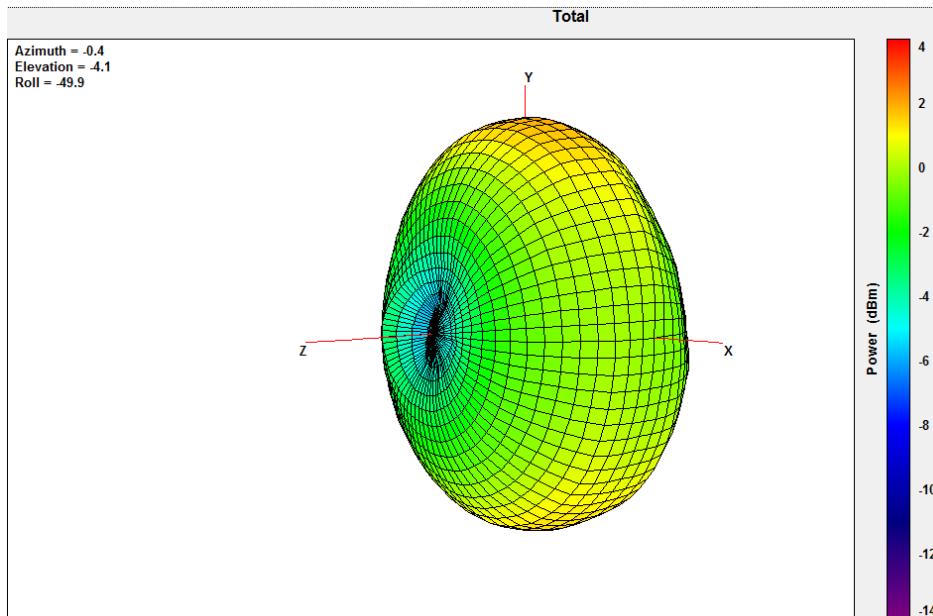

4900 MHz Pattern

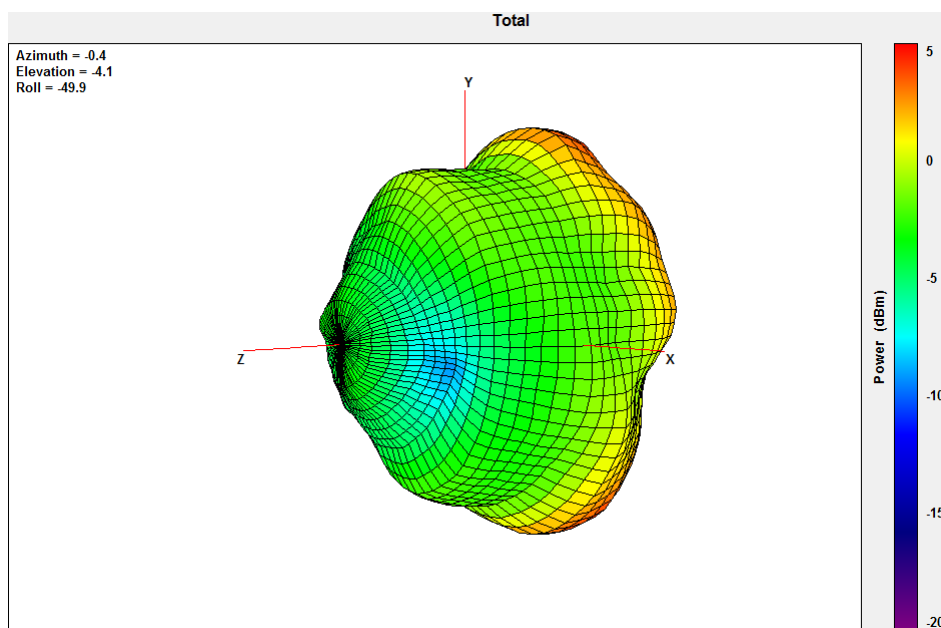

5500 MHz Pattern

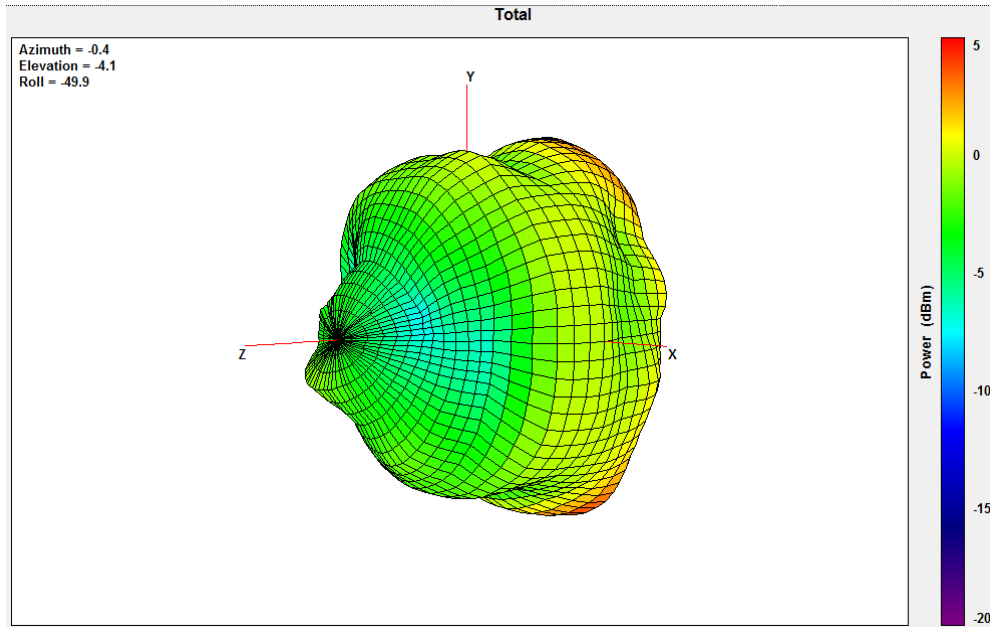

5900 MHz Pattern

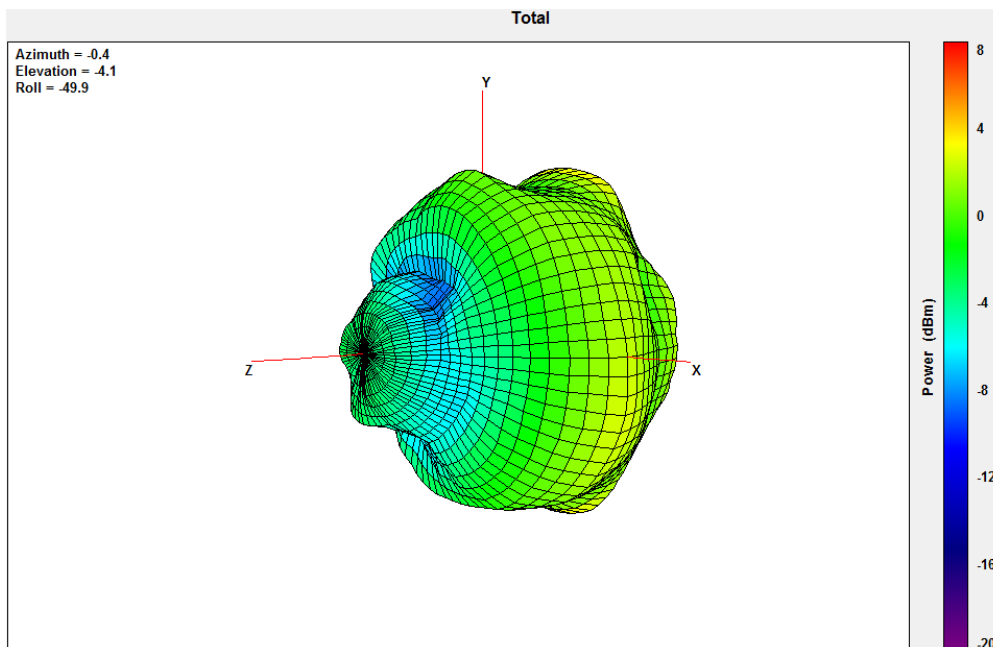

4. Mechanical Drawing.

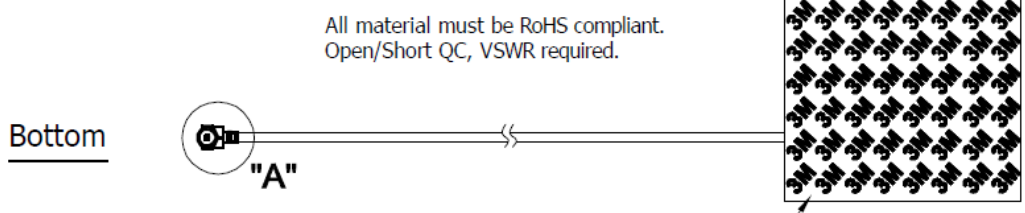
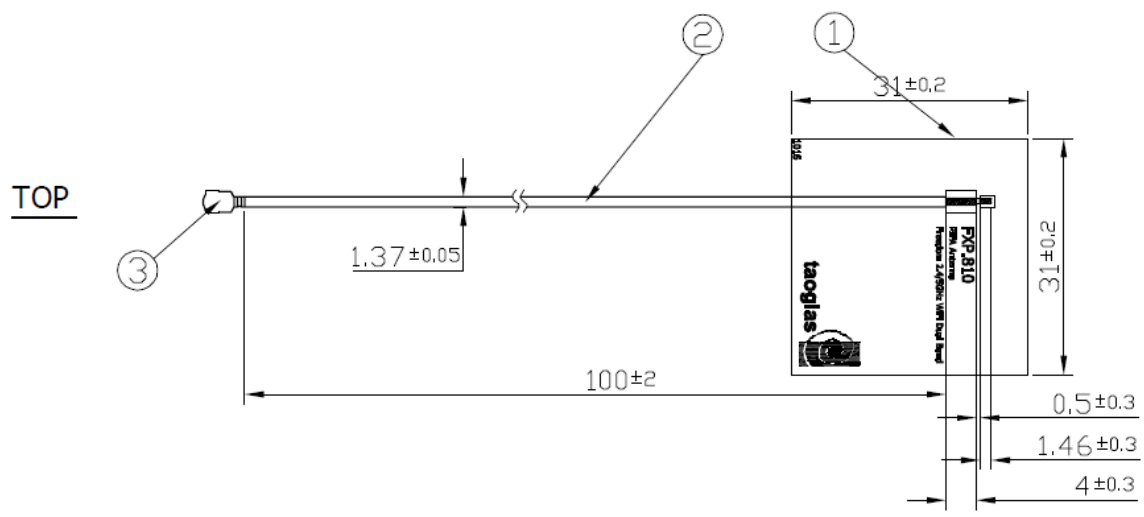

	Name	Material	Finish	QTY
①	FXP810 PCB	FPCB 0.1t	Black	1
②	1.37 Mini-Coaxial Cable	FEP	Gray	1
③	IPEX MHF1 (U.FL)	Brass	Gold	1
④	Double-Sided Adhesive	3M 467	Brown Liner	1

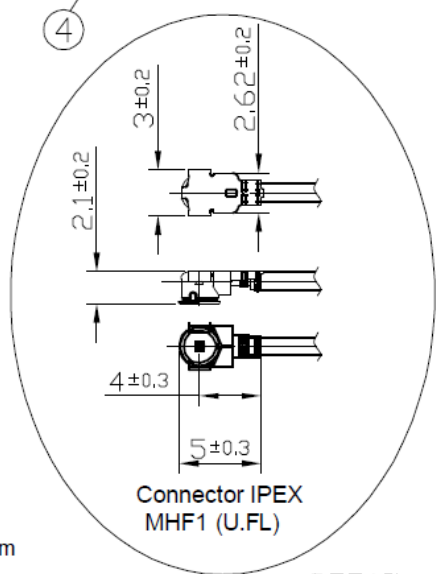

NOTES:
 1.NO DREGS OR INSUFFICIENT SOLDERING. SOLDER THICKNESS 1 ~1.7mm
 2.THE SOLDER MUST BE SMOOTH AND FULL TO THE EDGES OF THE PAD.
 THE SOLDER MUST NOT EXTEND OUTSIDE OF THE PAD AREA.
 3.THE CONNECTOR POSITION HAS SPECIAL ORIENTATION TO THE PCB AS PER DRAWING.

DETAIL : "A"
SCALE: 2/1

5. Packaging

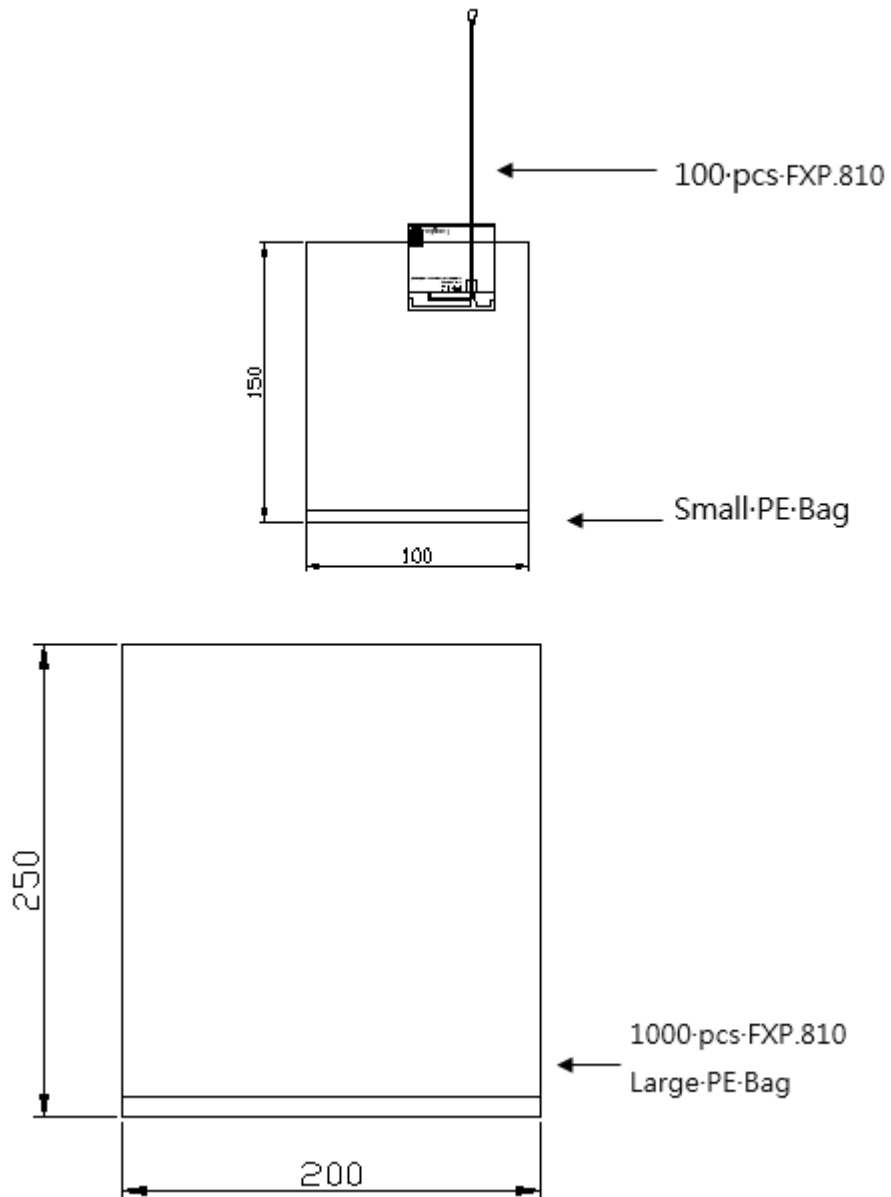

Taoglas makes no warranties based on the accuracy or completeness of the contents of this document and reserves the right to make changes to specifications and product descriptions at any time without notice. Taoglas reserves all rights to this document and the information contained herein.

Reproduction, use or disclosure to third parties without express permission is strictly prohibited.

Copyright © Taoglas Ltd.



Компания «ЭлектроПласт» предлагает заключение долгосрочных отношений при поставках импортных электронных компонентов на взаимовыгодных условиях!

Наши преимущества:

- Оперативные поставки широкого спектра электронных компонентов отечественного и импортного производства напрямую от производителей и с крупнейших мировых складов;
- Поставка более 17-ти миллионов наименований электронных компонентов;
- Поставка сложных, дефицитных, либо снятых с производства позиций;
- Оперативные сроки поставки под заказ (от 5 рабочих дней);
- Экспресс доставка в любую точку России;
- Техническая поддержка проекта, помощь в подборе аналогов, поставка прототипов;
- Система менеджмента качества сертифицирована по Международному стандарту ISO 9001;
- Лицензия ФСБ на осуществление работ с использованием сведений, составляющих государственную тайну;
- Поставка специализированных компонентов (Xilinx, Altera, Analog Devices, Intersil, Interpoint, Microsemi, Aeroflex, Peregrine, Syfer, Eurofarad, Texas Instrument, Miteq, Cobham, E2V, MA-COM, Hittite, Mini-Circuits, General Dynamics и др.);

Помимо этого, одним из направлений компании «ЭлектроПласт» является направление «Источники питания». Мы предлагаем Вам помощь Конструкторского отдела:

- Подбор оптимального решения, техническое обоснование при выборе компонента;
- Подбор аналогов;
- Консультации по применению компонента;
- Поставка образцов и прототипов;
- Техническая поддержка проекта;
- Защита от снятия компонента с производства.



Как с нами связаться

Телефон: 8 (812) 309 58 32 (многоканальный)

Факс: 8 (812) 320-02-42

Электронная почта: org@eplast1.ru

Адрес: 198099, г. Санкт-Петербург, ул. Калинина, дом 2, корпус 4, литера А.