

LCD Segment Drivers

Multi- function LCD Segment Drivers

BU97510CKV-M

MAX 216 Segment(54SEGx4COM)

General Description

The BU97510CKV-M is 1/4 or 1/3-Duty general-purpose LCD driver that can be used for frequency display in electronic tuners under the control of a microcontroller. The BU97510CKV-M can drive up to 216 LCD Segments directly. The BU97510CKV-M can also control up to 6 general-purpose output ports.

Features

- AEC-Q100 Qualified (Note)
- Either 1/4 or 1/3-Duty can be selected with the Serial Control Data.
 - 1/4-Duty Drive: Up to 216 Segments
 - 1/3-Duty Drive: Up to 162 Segments
- Serial Data Control of Frame Frequency for Common and Segment Output Waveforms.
- Serial Data Control of Switching between the Segment Output Port , PWM Output Port and General-purpose Output Port Functions.(Max 6 port)
- Built-in OSC Circuit
- The INHb Pin can force the Display to the off state.
- Integrated Power-on Reset Circuit
- No External Component
- Low Power Consumption Design
(Note) Grade 3

Applications

- Car Audio, Home Electrical Appliance, Meter Equipment etc.

Key Specifications

- Supply Voltage Range: +2.7V to +6.0V
- Operating Temperature Range: -40°C to +85°C
- Max Segments: 216 Segments
- Display Duty: 1/3, 1/4 Selectable
- Bias: 1/2, 1/3 Selectable
- Interface: 3wire Serial Interface

Packages

VQFP64 W(Typ.) × D(Typ.) × H(Max.)

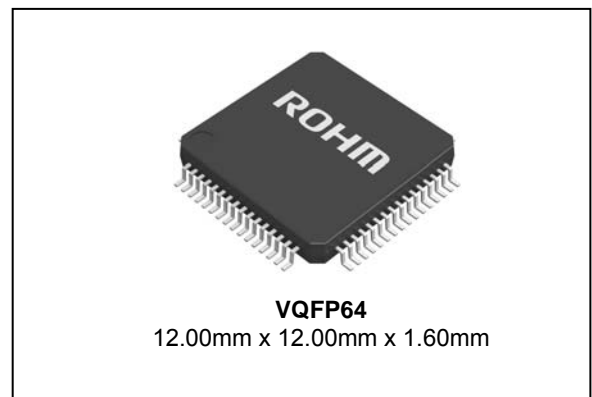

Typical Application Circuit

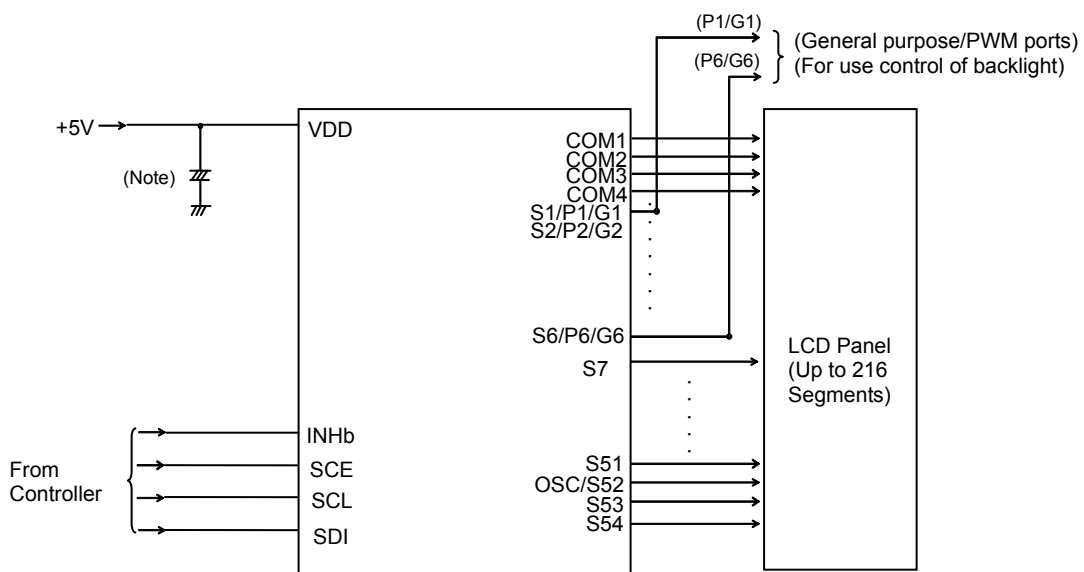

Figure 1. Typical Application Circuit

Block Diagram

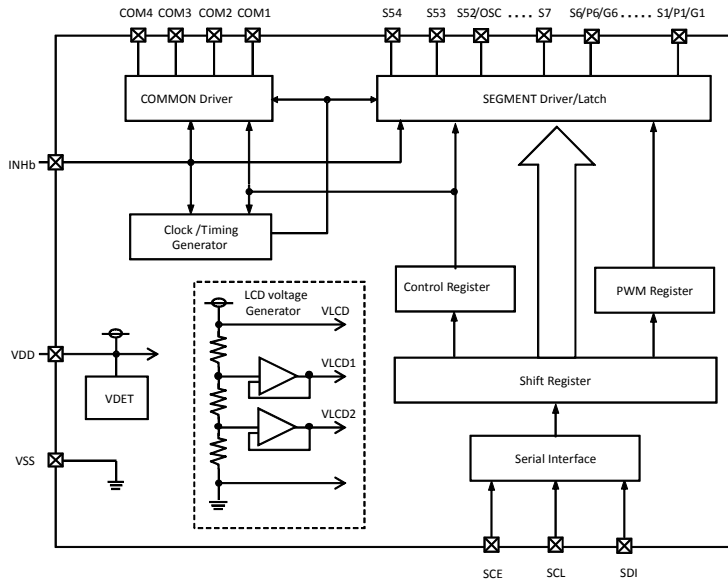

Figure 2. Block Diagram

Pin Arrangement

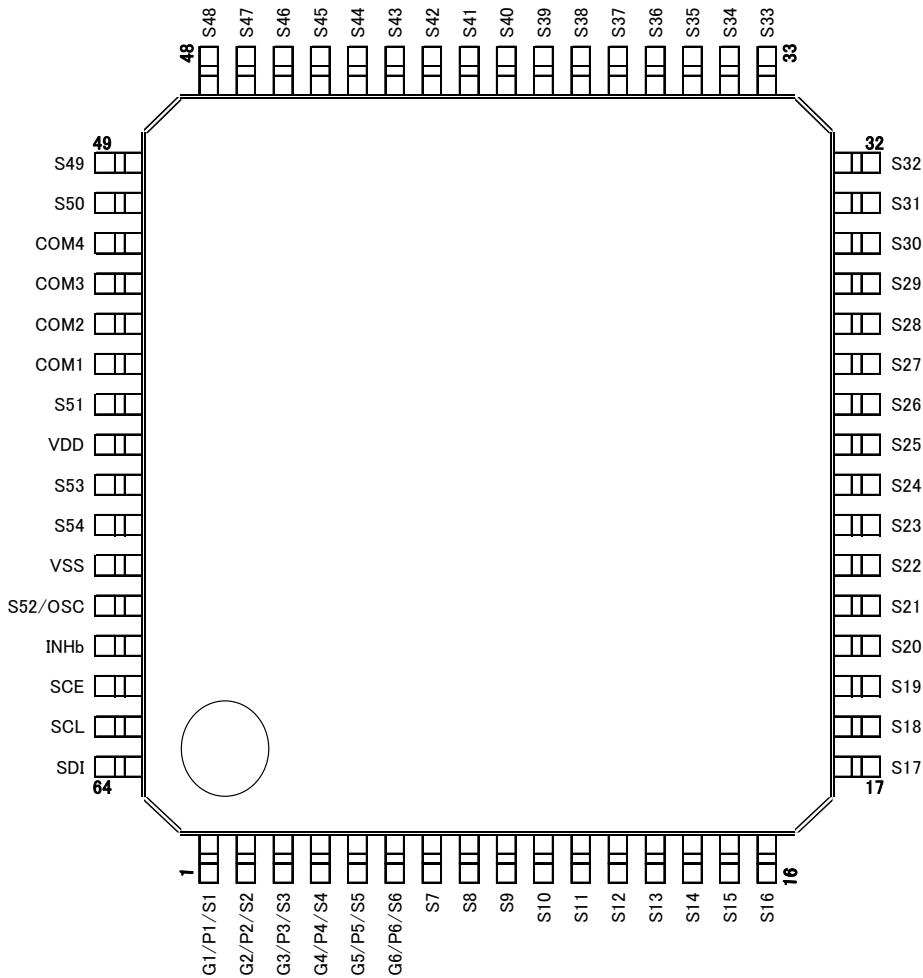

Figure 3. Pin Configuration (TOP VIEW)

Absolute Maximum Ratings(Ta = 25°C, VSS = 0.0V)

Parameter	Symbol	Conditions	Ratings	Unit
Maximum Supply Voltage	VDD max	VDD	-0.3 to +6.5	V
Input Voltage	VIN1	SCE, SCL, SDI, INHb	-0.3 to +6.5	V
Allowable Loss	Pd		1.0 ^(Note)	W
Operating Temperature	Topr		-40 to +85	°C
Storage Temperature	Tstg		-55 to +125	°C

(Note) When use more than Ta=25°C, subtract 10mW per degree. (Using ROHM standard board)

(Board size: 70mm×70mm×1.6mm material: FR4 board copper foil: land pattern only)

Caution: Operating the IC over absolute maximum ratings may damage the IC. The damage can either be a short circuit between pins or an open circuit between pins and the internal circuitry. Therefore, it is important to consider circuit protection measures, such as adding a fuse, in case the IC is operated over the absolute maximum ratings.

Recommended Operating Conditions (Ta = -40 to +85°C, VSS = 0.0V)

Parameter	Symbol	Conditions	Ratings			Unit
			Min	Typ	Max	
Supply Voltage	VDD	VDD	2.7		6.0	V

Electrical Characteristics (Ta = -40 to +85°C, VDD = 2.7V to 6.0V, VSS = 0.0V)

Parameter	Symbol	Pin	Conditions	Ratings			Unit
				Min	Typ	Max	
Hysteresis	VH	SCE, SCL, SDI, INHb, OSC		-	0.03VDD	-	V
Power-On Detection Voltage	VDET	VDD		1.4	1.8	2.2	V
"H" Level Input Voltage	VIH1	SCE, SCL, SDI, INHb, OSC	VDD=4.0V to 6.0V	0.4VDD	-	VDD	V
	VIH2	SCE, SCL, SDI, INHb, OSC	VDD=2.7V to 4.0V	0.8VDD	-	VDD	V
"L" Level Input Voltage	VIL1	SCE, SCL, SDI, INHb, OSC		0	-	0.2VDD	V
"H" Level Input Current	IIH1	SCE, SCL, SDI, INHb, OSC	VI = 6.0V	-	-	5.0	μA
"L" Level Input Current	IIL1	SCE, SCL, SDI, INHb, OSC	VI = 0V	-5.0	-	-	μA
"H" Level Output Voltage	VOH1	S1 to S54	IO = -20μA	VDD-0.9	-	-	V
	VOH2	COM1 to COM4	IO = -100μA	VDD-0.9	-	-	
	VOH3	P1/G1 to P6/G6	IO = -1mA	VDD-0.9	-	-	
"L" Level Output Voltage	VOL1	S1 to S54	IO = 20μA	-	-	0.9	V
	VOL2	COM1 to COM4	IO = 100μA	-	-	0.9	
	VOL3	P1/G1 to P6/G6	IO = 1mA	-	-	0.9	
Middle Level Output Voltage	VMID1	S1 to S54	1/2-Bias IO = ±20μA	1/2VDD -0.9	-	1/2VDD +0.9	V
	VMID2	COM1 to COM4	1/2-Bias IO = ±100μA	1/2VDD -0.9	-	1/2VDD +0.9	
	VMID3	S1 to S54	1/3-Bias IO = ±20μA	2/3VDD -0.9	-	2/3VDD +0.9	
	VMID4	S1 to S54	1/3-Bias IO = ±20μA	1/3VDD -0.9	-	1/3VDD +0.9	
	VMID5	COM1 to COM4	1/3-Bias IO = ±100μA	2/3VDD -0.9	-	2/3VDD +0.9	
	VMID6	COM1 to COM4	1/3-Bias IO = ±100μA	1/3VDD -0.9	-	1/3VDD +0.9	
Current Drain	IDD1	VDD	Power-saving mode	-	-	15	μA
	IDD2	VDD	VDD = 5.0V Output open 1/2-Bias Frame Frequency = 80Hz	-	70	150	
	IDD3	VDD	VDD = 5.0V Output open 1/3-Bias Frame Frequency = 80Hz	-	95	200	

Oscillation Characteristics (Ta = -40 to +85°C, VDD = 2.7V to 6.0V, VSS = 0.0V)

Parameter	Symbol	Pin	Conditions	Ratings			Unit
				Min	Typ	Max	
Oscillator Frequency1	fosc1	Internal Oscillator Circuit	VDD = 2.7V to 6.0V	150	-	360	kHz
Oscillator Frequency2	fosc2		VDD = 5.0V	255	300	345	kHz
External Clock Frequency ^(Note3)	fosc3	OSC	External clock mode (OC=1)	30	-	600	kHz

(Note3) Frame frequency is decided external frequency and dividing ratio of FC0-2 setting.

【Reference Data】

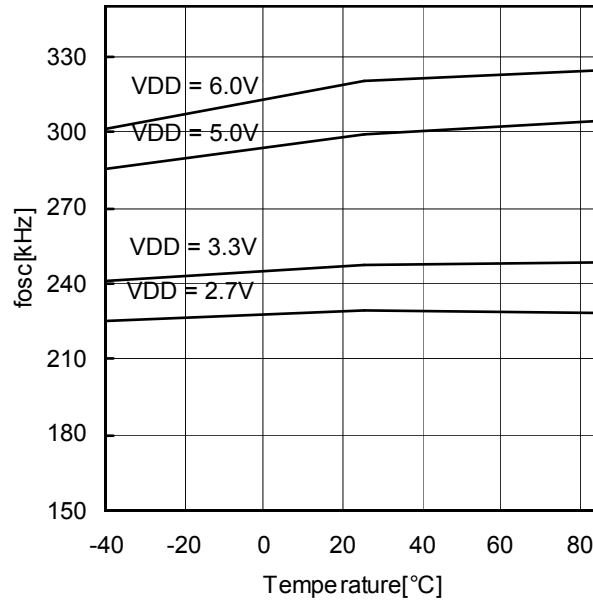
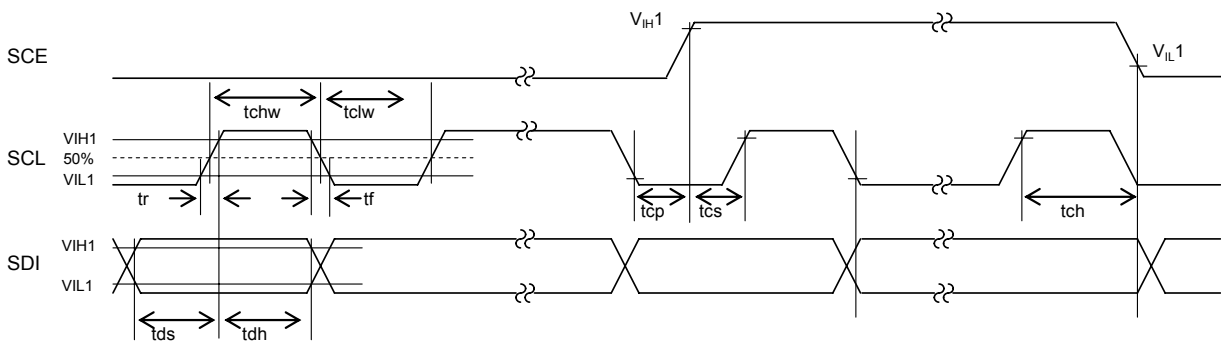

Figure 4. Typical Temperature Characteristics

MPU Interface Characteristics (Ta = -40 to +85°C, VDD = 2.7V to 6.0V, VSS = 0.0V)

Parameter	Symbol	Pin	Conditions	Ratings			Unit
				Min	Typ	Max	
Data Setup Time	tds	SCL, SDI		160	-	-	ns
Data Hold Time	tdh	SCL, SDI		160	-	-	ns
SCE Wait Time	tcp	SCE, SCL		160	-	-	ns
SCE Setup Time	tcs	SCE, SCL		160	-	-	ns
SCE Hold Time	tch	SCE, SCL		160	-	-	ns
High-Level Clock Pulse Width	tchh	SCL		160	-	-	ns
Low-Level Clock Pulse Width	tchl	SCL		160	-	-	ns
Rise Time	tr	SCE, SCL, SDI		-	160	-	ns
Fall Time	tf	SCE, SCL, SDI		-	160	-	ns
INH Switching Time	tc	INHb, SCE		10	-	-	µs

1. When SCL is stopped at the low level



2. When SCL is stopped at the high level

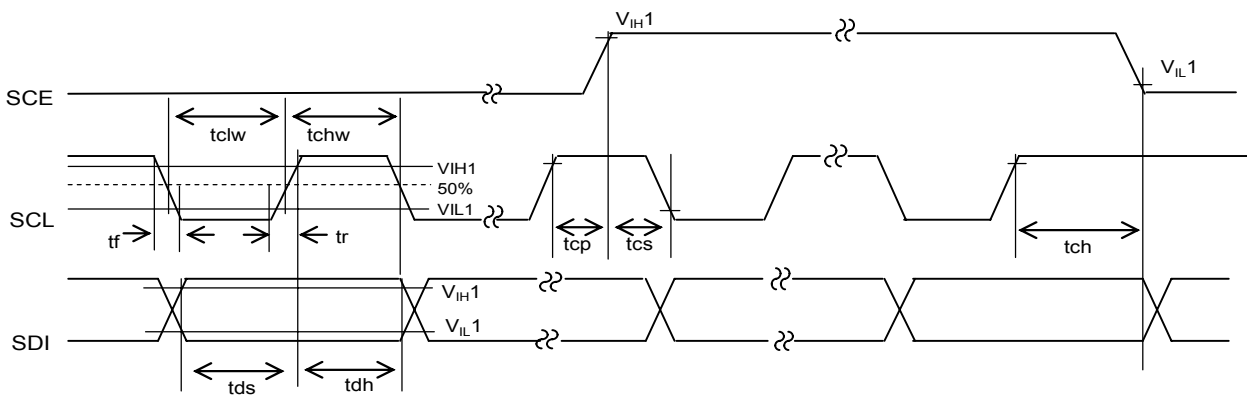

Figure 5. Serial Interface Timing

Pin Description

Symbol	Pin No.	Function	Active	I/O	Handling when unused
S1/P1/G1 to S6/P6/G6 S7 to S54	1 to 6 7 to 50 55,57,58	Segment output. The S1/P1/G1 to S6/P6/G6 pins can be used as general -purpose outputs.	-	O	OPEN
COM1 to COM4	51 to 54	Common driver output pins. The frame frequency is fo[Hz].	-	O	OPEN
S52/OSC	60	Segment output. The pin S52/OSC can be used external frequency input pin when set up by the control data.	-	I/O	OPEN
SCE SCL SDI	62 63 64	Serial data transfer inputs. Must be connected to the controller. SCE: Chip enable SCL: Synchronization clock SDI: Transfer data	H - -	I I I	GND
INHb	61	Display off control input • INHb = low (VSS) ...Display forced off S1/P1/G1 to S6/P6/G6 = low (VSS) S7 to S54 = low (VSS) COM1 to COM4 = low (VSS) Shuts off current to the LCD drive bias voltage generation divider resistors. Stop the internal oscillation circuit. • INHb = high (VDD)...Display on However, serial data transfer is possible when the display is forced off.	L	I	VDD
V _{DD}	56	Power supply pin for the logic circuit block. A power voltage of 2.7V to 6.0V must be applied to this pin.	-	-	-
V _{SS}	59	Power supply pin. Must be connected to ground.	-	-	-

IO Equivalence Circuit

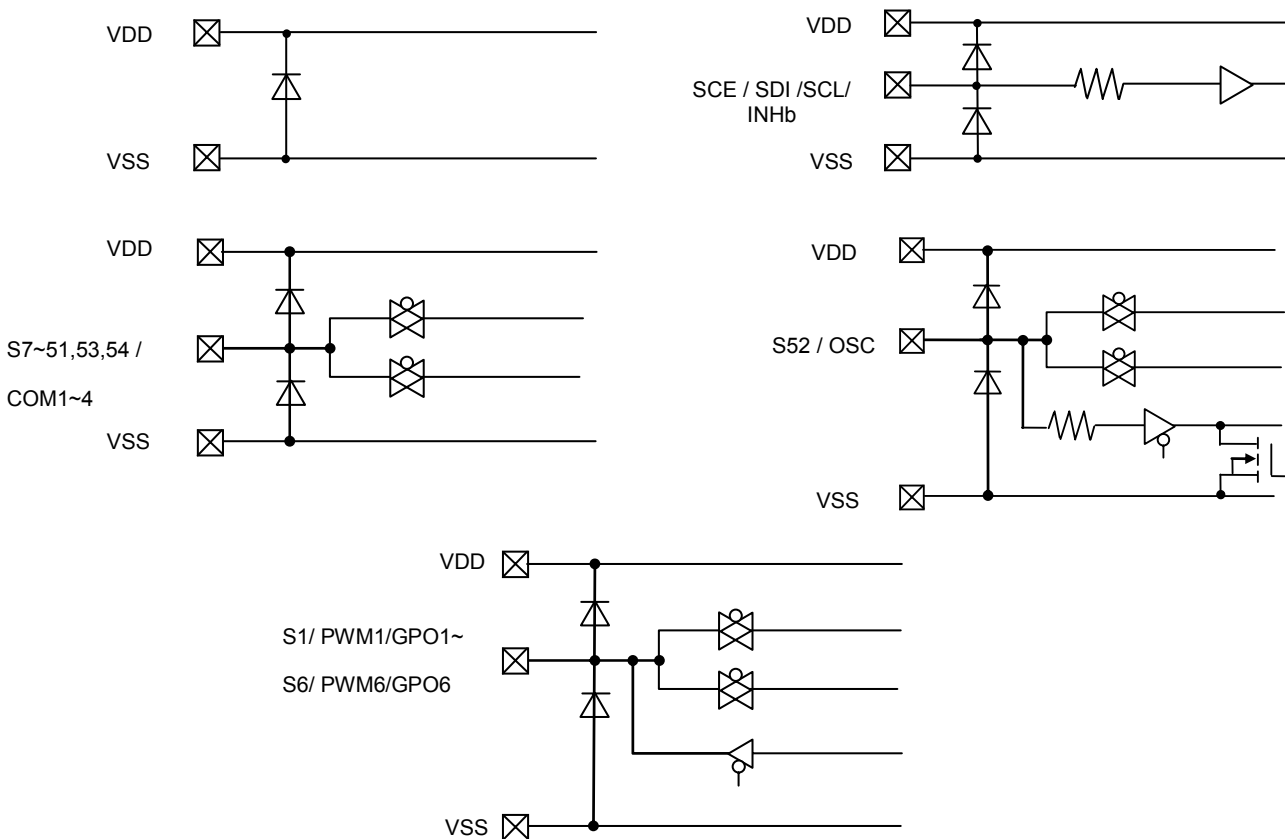

Figure 6. I/O Equivalence Circuit

Serial Data Transfer Formats

1. 1/4-Duty

(1) When SCL is stopped at the low level

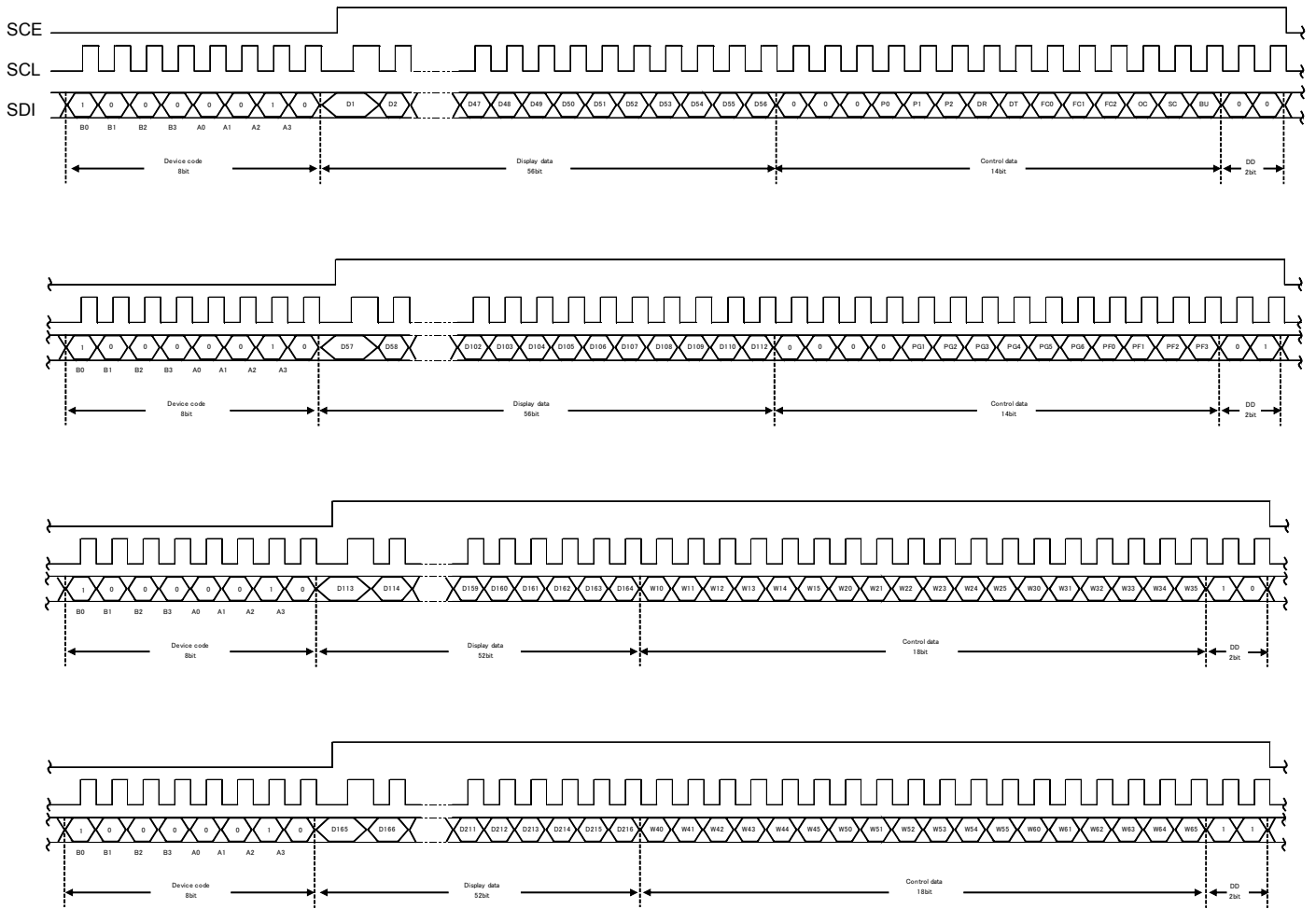

Figure 7. 3-SPI Data Transfer Format

Note : DD is direction data.

(2) When SCL is stopped at the high level

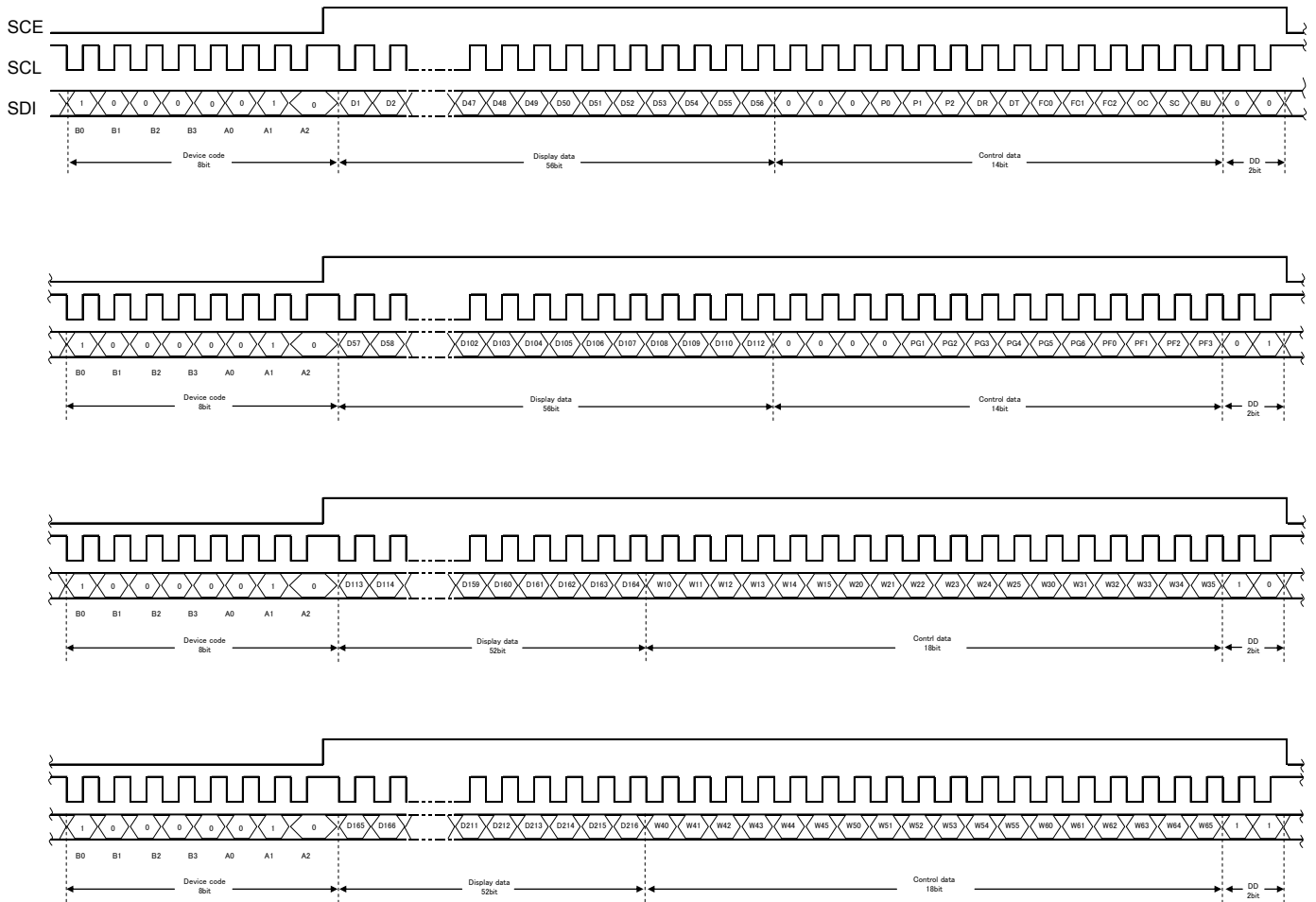

Figure 8. 3-SPI Data Transfer Format

Note : DD is direction data.

- Device code....."41H"
- D1~D216.....Display data
- P0~2.....Segment / PWM / General Purpose output port switching control data
- DR.....1/3-Bias drive or 1/2-Bias drive switching control data
- DT.....1/4-Duty drive or 1/3-Duty drive switching control data
- FC0~FC2.....Frame frequency switching control data
- OC.....Internal oscillator operating mode/External clock operating mode switching control data
- SC.....Segment on/off switching control data
- BU.....Normal mode/power-saving mode switching control data
- PG1~PG6.....PWM/General Purpose output switching control data
- PF0~PF3.....PWM output waveform frame frequency switching control data
- W10~W15, W20~W25, W30~W35, W40~W45, W50~W55, W60~W65
.....PWM output waveform duty switching control data

2. 1/3-Duty

(1) When SCL is stopped at the low level

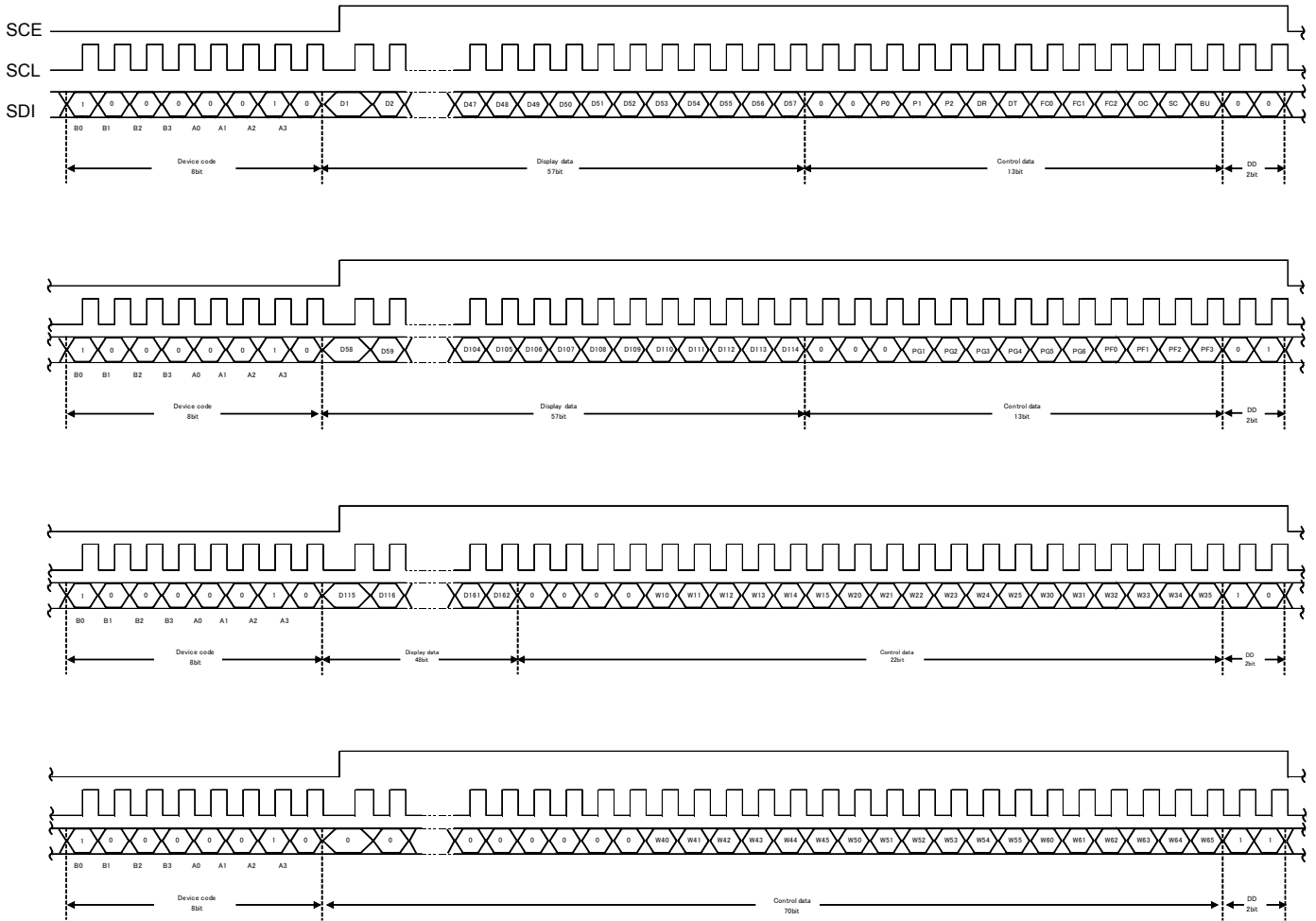

Figure 9. 3-SPI Data Transfer Format

Note : DD is direction data.

(2) When SCL is stopped at the high level

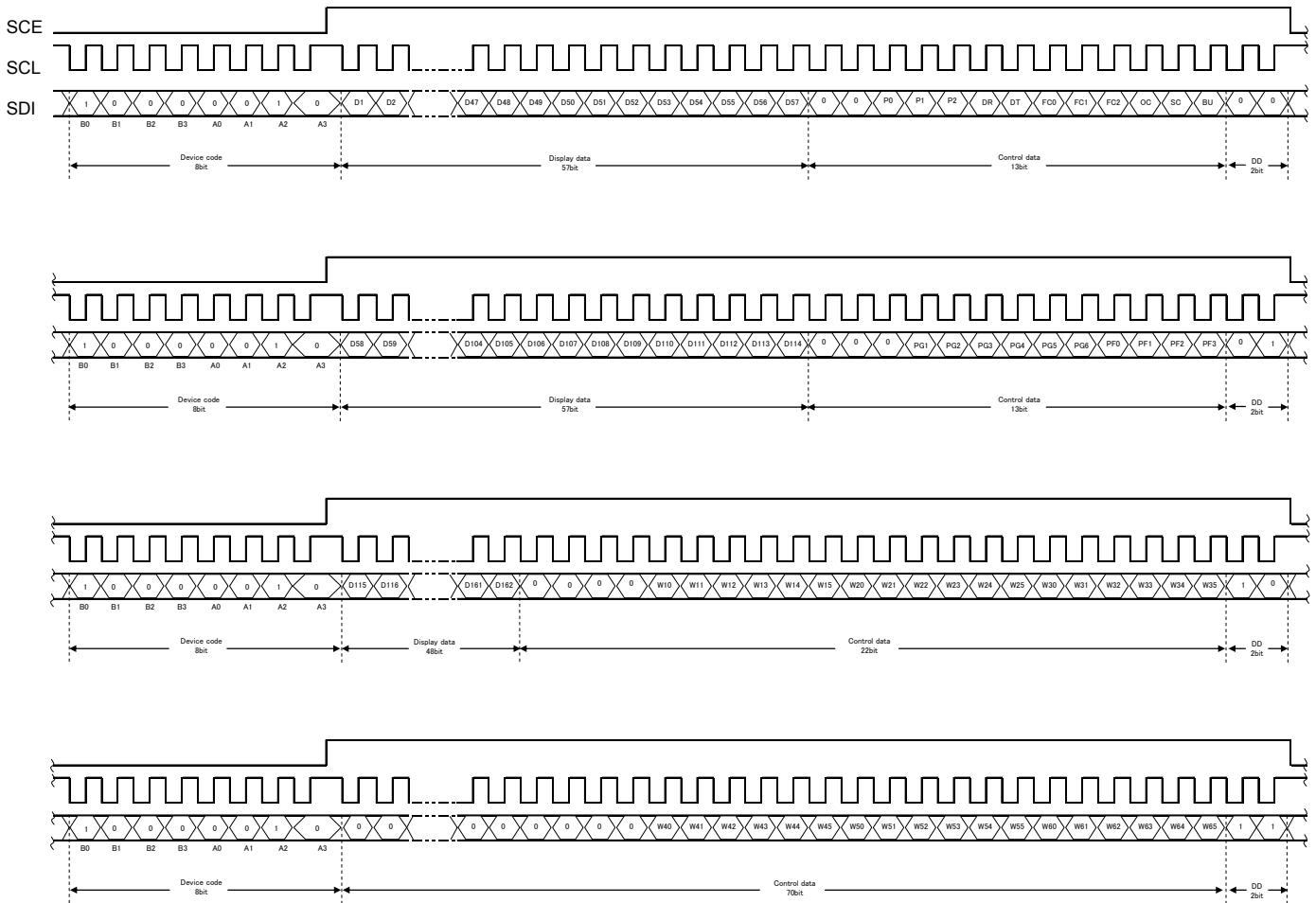

Figure 10. 3-SPI Data Transfer Format

Note : DD is direction data.

- Device code....."41H"
- D1~D162.....Display data
- P0~2.....Segment / PWM / General Purpose output port switching control data
- DR.....1/3-Bias drive or 1/2-Bias drive switching control data
- DT.....1/4-Duty drive or 1/3-Duty drive switching control data
- FC0~FC2.....Frame frequency switching control data
- OC.....Internal oscillator operating mode/External clock operating mode switching control data
- SC.....Segment on/off switching control data
- BU.....Normal mode/power-saving mode switching control data
- PG1~PG6.....PWM/General Purpose output switching control data
- PF0~PF3.....PWM output waveform frame frequency switching control data
- W10~W15, W20~W25, W30~W35, W40~W45, W50~W55, W60~W65
.....PWM output waveform duty switching control data

Control Data Functions

1. P0₀ P2: Segment / PWM / General Purpose output port switching control data

These control bits are used to select the function of the S1/P1 to S6/P6 output pins (Segment Output Pins or PWM Output Pins or General Purpose Output Pins).

Please refer to the table below.

P0	P1	P2	S1/P1/G1	S2/P2/G2	S3/P3/G3	S4/P4/G4	S5/P5/G5	S6/P6/G6
0	0	0	S1	S2	S3	S4	S5	S6
0	0	1	P1/G1	S2	S3	S4	S5	S6
0	1	0	P1/G1	P2/G2	S3	S4	S5	S6
0	1	1	P1/G1	P2/G2	P3/G3	S4	S5	S6
1	0	0	P1/G1	P2/G2	P3/G3	P4/G4	S5	S6
1	0	1	P1/G1	P2/G2	P3/G3	P4/G4	P5/G5	S6
1	1	0	P1/G1	P2/G2	P3/G3	P4/G4	P5/G5	P6/G6
1	1	1	S1	S2	S3	S4	S5	S6

PWM output or General Purpose output is selected by PGx(x=1₀ 6) control data bit.

When the General Purpose Output Port Function is selected, the correspondence between the output pins and the respective display data is given in the table below.

Output Pins	Corresponding Display Data	
	1/4-Duty mode	1/3-Duty mode
S1/P1/G1	D1	D1
S2/P2/G2	D5	D4
S3/P3/G3	D9	D7
S4/P4/G4	D13	D10
S5/P5/G5	D17	D13
S6/P6/G6	D21	D16

When the General Purpose Output Port Function is selected, the respective output pin is output a "HIGH" level when its corresponding display data is set to "1". Likewise, it will output a "LOW" level, if its corresponding display data is set to "0".

For example, S4/P4/G4 is used as a General Purpose Output Port, if its corresponding display data – D13 is set to "1", then S4/P4/G4 will output "HIGH" level. Likewise, if D13 is set to "0", then S4/P4/G4 will output "LOW" level.

2. DR: 1/3-Bias drive or 1/2-Bias drive switching control data

This control data bit selects either 1/3-Bias drive or 1/2-Bias drive.

DR	Bias drive scheme
0	1/3-Bias drive
1	1/2-Bias drive

3. DT: 1/4-Duty drive or 1/3-Duty drive switching control data

This control data bit selects either 1/4-Duty drive or 1/3-Duty drive.

DT	Duty drive scheme
0	1/4-Duty drive
1	1/3-Duty drive

4. FC0, FC1, FC2: Frame frequency switching control data

These control data bits set the frame frequency for common and segment output waveforms.

FC0	FC1	FC2	Frame Frequency fo(Hz)
0	0	0	fosc/6144
0	0	1	fosc/5376
0	1	0	fosc/4608
0	1	1	fosc/3840
1	0	0	fosc/3072
1	0	1	fosc/2304
1	1	0	fosc/1920
1	1	1	fosc/1536

Note: fosc: Internal oscillation frequency (300 [kHz] typ.)

5. OC: Internal oscillator operating mode/External clock operating mode switching control data

OC	Operating mode	In/Out pin(S52/OSC) status
0	Internal oscillator	S52 (segment output)
1	External Clock	OSC (clock input)

6. SC: Segment on/off switching control data

This control data bit controls the on/off state of the segments.

SC	Display state
0	On
1	Off

Note that when the segments are turned off by setting SC to "1", the segments are turned off by outputting segment off waveforms from the segment output pins.

7. BU: Normal mode/power-saving mode switching control data

This control data bit selects either normal mode or power-saving mode.

BU	Mode
0	Normal Mode
1	Power-saving Mode

Power-saving mode status: S1/P1/G1 to S6/P6/G6 = active only General Purpose output
 S7 to S54 = low(VSS)
 COM1 to COM4 = low(VSS)
 Shut off current to the LCD drive bias voltage generation circuit
 Stop the Internal oscillation circuit
 However, serial data transfer is possible when Power-saving mode.

8. PG1, PG2, PG3, PG4, PG5, PG6: PWM/General Purpose output switching control data

This control data bit select either PWM output or General Purpose output of Sx/Px/Gx pins.(x=1~6)

PGx(x=1~6)	Mode
0	PWM output
1	General Purpose output

<Note: PWM<->GPO Changing function>

Normal behavior of changing GPO to PWM is below.

- PWM operation is started by command import timing of DD: 01 during GPO ----> PWM change.
- Please take care of reflect timing of new duty setting of DD: 10, DD: 11 is from the next PWM.

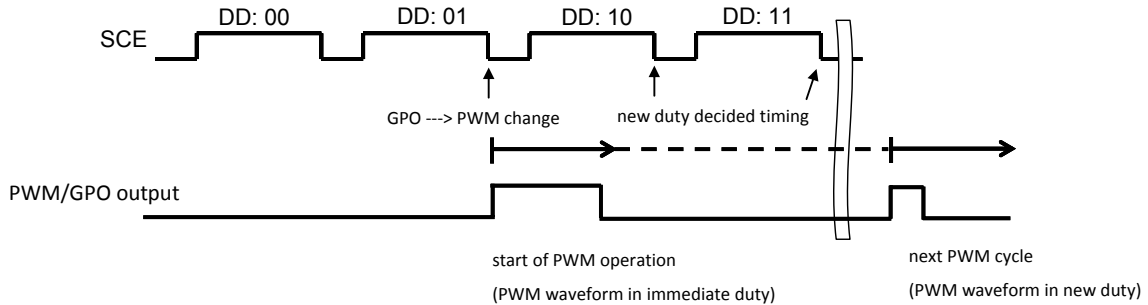

In order to avoid this operation, please input commands reversely as below.

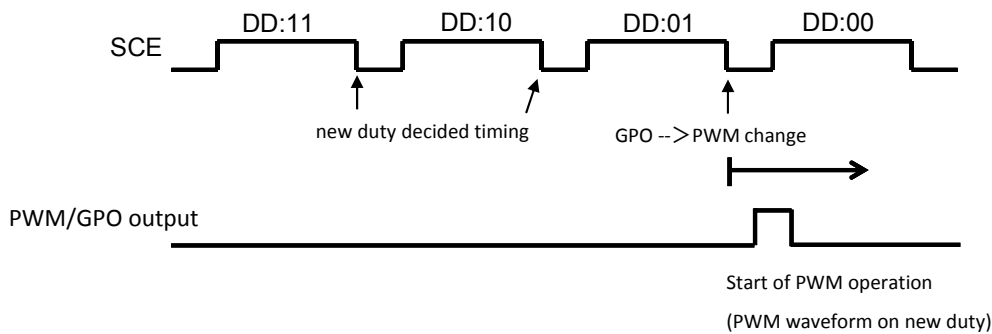

9. PF0, PF1, PF2, PF3: PWM output waveform frame frequency switching control data

These control data bits set the frame frequency for PWM output waveforms.

PF0	PF1	PF2	PF3	PWM output Frame Frequency fp(Hz)
0	0	0	0	fosc/2048
0	0	0	1	fosc/1920
0	0	1	0	fosc/1792
0	0	1	1	fosc/1664
0	1	0	0	fosc/1536
0	1	0	1	fosc/1408
0	1	1	0	fosc/1280
0	1	1	1	fosc/1152
1	0	0	0	fosc/1024
1	0	0	1	fosc/896
1	0	1	0	fosc/768
1	0	1	1	fosc/640
1	1	0	0	fosc/512
1	1	0	1	fosc/384
1	1	1	0	fosc/256
1	1	1	1	fosc/128

10. W10~W15, W20~W25, W30~W35, W40~W45, W50~W55, W60~W65: PWM output waveform duty switching control data

These control data bits set the high level pulse width(duty) for PWM output waveforms.

Wn0	Wn1	Wn2	Wn3	Wn4	Wn5	PWM duty
0	0	0	0	0	0	(1/64) x Tp
1	0	0	0	0	0	(2/64) x Tp
0	1	0	0	0	0	(3/64) x Tp
1	1	0	0	0	0	(4/64) x Tp
0	0	1	0	0	0	(5/64) x Tp
1	0	1	0	0	0	(6/64) x Tp
0	1	1	0	0	0	(7/64) x Tp
1	1	1	0	0	0	(8/64) x Tp
0	0	0	1	0	0	(9/64) x Tp
1	0	0	1	0	0	(10/64) x Tp
0	1	0	1	0	0	(11/64) x Tp
1	1	0	1	0	0	(12/64) x Tp
0	0	1	1	0	0	(13/64) x Tp
1	0	1	1	0	0	(14/64) x Tp
0	1	1	1	0	0	(15/64) x Tp
1	1	1	1	0	0	(16/64) x Tp
0	0	0	0	1	0	(17/64) x Tp
1	0	0	0	1	0	(18/64) x Tp
0	1	0	0	1	0	(19/64) x Tp
1	1	0	0	1	0	(20/64) x Tp
0	0	1	0	1	0	(21/64) x Tp
1	0	1	0	1	0	(22/64) x Tp
0	1	1	0	1	0	(23/64) x Tp
1	1	1	0	1	0	(24/64) x Tp
0	0	0	1	1	0	(25/64) x Tp
1	0	0	1	1	0	(26/64) x Tp
0	1	0	1	1	0	(27/64) x Tp
1	1	0	1	1	0	(28/64) x Tp
0	0	1	1	1	0	(29/64) x Tp
1	0	1	1	1	0	(30/64) x Tp
0	1	1	1	1	0	(31/64) x Tp
1	1	1	1	1	0	(32/64) x Tp

Wn0	Wn1	Wn2	Wn3	Wn4	Wn5	PWM duty
0	0	0	0	0	1	(33/64) x Tp
1	0	0	0	0	1	(34/64) x Tp
0	1	0	0	0	1	(35/64) x Tp
1	1	0	0	0	1	(36/64) x Tp
0	0	1	0	0	1	(37/64) x Tp
1	0	1	0	0	1	(38/64) x Tp
0	1	1	0	0	1	(39/64) x Tp
1	1	1	0	0	1	(40/64) x Tp
0	0	0	1	0	1	(41/64) x Tp
1	0	0	1	0	1	(42/64) x Tp
0	1	0	1	0	1	(43/64) x Tp
1	1	0	1	0	1	(44/64) x Tp
0	0	1	1	0	1	(45/64) x Tp
1	0	1	1	0	1	(46/64) x Tp
0	1	1	1	0	1	(47/64) x Tp
1	1	1	1	0	1	(48/64) x Tp
0	0	0	0	1	1	(49/64) x Tp
1	0	0	0	1	1	(50/64) x Tp
0	1	0	0	1	1	(51/64) x Tp
1	1	0	0	1	1	(52/64) x Tp
0	0	1	0	1	1	(53/64) x Tp
1	0	1	0	1	1	(54/64) x Tp
0	1	1	0	1	1	(55/64) x Tp
1	1	1	0	1	1	(56/64) x Tp
0	0	0	1	1	1	(57/64) x Tp
1	0	0	1	1	1	(58/64) x Tp
0	1	0	1	1	1	(59/64) x Tp
1	1	0	1	1	1	(60/64) x Tp
0	0	1	1	1	1	(61/64) x Tp
1	0	1	1	1	1	(62/64) x Tp
0	1	1	1	1	1	(63/64) x Tp
1	1	1	1	1	1	(64/64) x Tp

Note: W10~W15: S1/P1/G1 PWM duty data
 W20~W25: S2/P2/G2 PWM duty data
 W30~W35: S3/P3/G3 PWM duty data
 W40~W45: S4/P4/G4 PWM duty data
 W50~W55: S5/P5/G5 PWM duty data
 W60~W65: S6/P6/G6 PWM duty data

n = 1~6
 Tp = 1/fp

Display Data and Output Pin Correspondence

1. 1/4-Duty

Output pin	COM1	COM2	COM3	COM4
S1/P1/G1	D1	D2	D3	D4
S2/P2/G2	D5	D6	D7	D8
S3/P3/G3	D9	D10	D11	D12
S4/P4/G4	D13	D14	D15	D16
S5/P5/G5	D17	D18	D19	D20
S6/P6/G6	D21	D22	D23	D24
S7	D25	D26	D27	D28
S8	D29	D30	D31	D32
S9	D33	D34	D35	D36
S10	D37	D38	D39	D40
S11	D41	D42	D43	D44
S12	D45	D46	D47	D48
S13	D49	D50	D51	D52
S14	D53	D54	D55	D56
S15	D57	D58	D59	D60
S16	D61	D62	D63	D64
S17	D65	D66	D67	D68
S18	D69	D70	D71	D72
S19	D73	D74	D75	D76
S20	D77	D78	D79	D80
S21	D81	D82	D83	D84
S22	D85	D86	D87	D88
S23	D89	D90	D91	D92
S24	D93	D94	D95	D96
S25	D97	D98	D99	D100
S26	D101	D102	D103	D104
S27	D105	D106	D107	D108
S28	D109	D110	D111	D112
S29	D113	D114	D115	D116
S30	D117	D118	D119	D120
S31	D121	D122	D123	D124
S32	D125	D126	D127	D128
S33	D129	D130	D131	D132
S34	D133	D134	D135	D136
S35	D137	D138	D139	D140
S36	D141	D142	D143	D144
S37	D145	D146	D147	D148
S38	D149	D150	D151	D152
S39	D153	D154	D155	D156
S40	D157	D158	D159	D160
S41	D161	D162	D163	D164
S42	D165	D166	D167	D168
S43	D169	D170	D171	D172
S44	D173	D174	D175	D176
S45	D177	D178	D179	D180
S46	D181	D182	D183	D184
S47	D185	D186	D187	D188
S48	D189	D190	D191	D192
S49	D193	D194	D195	D196
S50	D197	D198	D199	D200
S51	D201	D202	D203	D204
S52	D205	D206	D207	D208
S53	D209	D210	D211	D212
S54	D213	D214	D215	D216

Note: The Segment Output Port function is assumed to be selected for the output pins – S1/P1/G1 to S6/P6/G6.

To illustrate further, the states of the S21 output pin is given in the table below.

Display data				State of S21 Output Pin
D81	D82	D83	D84	
0	0	0	0	LCD Segments corresponding to COM1 to COM4 are OFF.
0	0	0	1	LCD Segment corresponding to COM4 is ON.
0	0	1	0	LCD Segment corresponding to COM3 is ON.
0	0	1	1	LCD Segments corresponding to COM3 and COM4 are ON.
0	1	0	0	LCD Segment corresponding to COM2 is ON.
0	1	0	1	LCD Segments corresponding to COM2 and COM4 are ON.
0	1	1	0	LCD Segments corresponding to COM2 and COM3 are ON.
0	1	1	1	LCD Segments corresponding to COM2, COM3 and COM4 are ON.
1	0	0	0	LCD Segment corresponding to COM1 is ON.
1	0	0	1	LCD Segments corresponding to COM1 and COM4 are ON.
1	0	1	0	LCD Segments corresponding to COM1 and COM3 are ON.
1	0	1	1	LCD Segments corresponding to COM1, COM3 and COM4 are ON.
1	1	0	0	LCD Segments corresponding to COM1 and COM2 are ON.
1	1	0	1	LCD Segments corresponding to COM1, COM2, and COM4 are ON.
1	1	1	0	LCD Segments corresponding to COM1, COM2, and COM3 are ON.
1	1	1	1	LCD Segments corresponding to COM1 to COM 4 are ON.

2. 1/3-Duty

Output pin	COM1	COM2	COM3
S1/P1/G1	D1	D2	D3
S2/P2/G2	D4	D5	D6
S3/P3/G3	D7	D8	D9
S4/P4/G4	D10	D11	D12
S5/P5/G5	D13	D14	D15
S6/P6/G6	D16	D17	D18
S7	D19	D20	D21
S8	D22	D23	D24
S9	D25	D26	D27
S10	D28	D29	D30
S11	D31	D32	D33
S12	D34	D35	D36
S13	D37	D38	D39
S14	D40	D41	D42
S15	D43	D44	D45
S16	D46	D47	D48
S17	D49	D50	D51
S18	D52	D53	D54
S19	D55	D56	D57
S20	D58	D59	D60
S21	D61	D62	D63
S22	D64	D65	D66
S23	D67	D68	D69
S24	D70	D71	D72
S25	D73	D74	D75
S26	D76	D77	D78
S27	D79	D80	D81
S28	D82	D83	D84
S29	D85	D85	D87
S30	D88	D89	D90
S31	D91	D92	D93
S32	D94	D95	D96
S33	D97	D98	D99
S34	D100	D101	D102
S35	D103	D104	D105
S36	D106	D107	D108
S37	D109	D110	D111
S38	D112	D113	D114
S39	D115	D116	D117
S40	D118	D119	D120
S41	D121	D122	D123
S42	D124	D125	D126
S43	D127	D128	D129
S44	D130	D131	D132
S45	D133	D134	D135
S46	D136	D137	D138
S47	D139	D140	D141
S48	D142	D143	D144
S49	D145	D146	D147
S50	D148	D149	D150
S51	D151	D152	D153
S52	D154	D155	D156
S53	D157	D158	D159
S54	D160	D161	D162

Note: The Segment Output Port function is assumed to be selected for the output pins – S1/P1/G1 to S6/P6/G6.

To illustrate further, the states of the S21 output pin is given in the table below.

Display data			State of S21 Output Pin
D61	D62	D63	
0	0	0	LCD Segments corresponding to COM1 to COM3 are OFF.
0	0	1	LCD Segment corresponding to COM3 is ON.
0	1	0	LCD Segment corresponding to COM2 is ON.
0	1	1	LCD Segments corresponding to COM2 and COM3 are ON.
1	0	0	LCD Segment corresponding to COM1 is ON.
1	0	1	LCD Segments corresponding to COM1 and COM3 are ON.
1	1	0	LCD Segments corresponding to COM1 and COM2 are ON.
1	1	1	LCD Segments corresponding to COM1, COM2 and COM3 are ON.

Output Waveforms (1/4-Duty 1/3-Bias Drive Scheme)

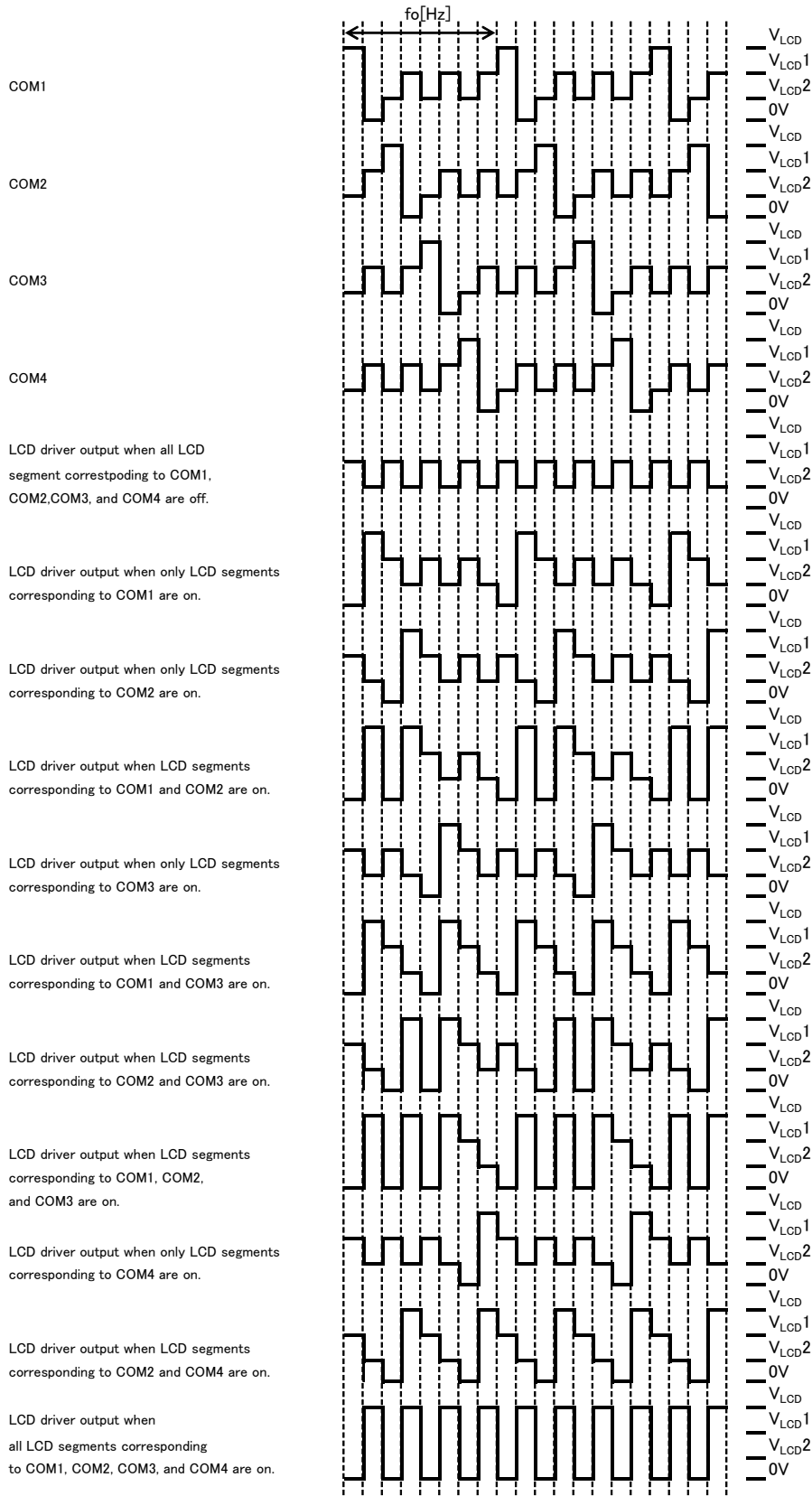

Figure 11. LCD Waveform (1/4-Duty, 1/3-Bias)

Output Waveforms (1/4-Duty 1/2-Bias Drive Scheme)

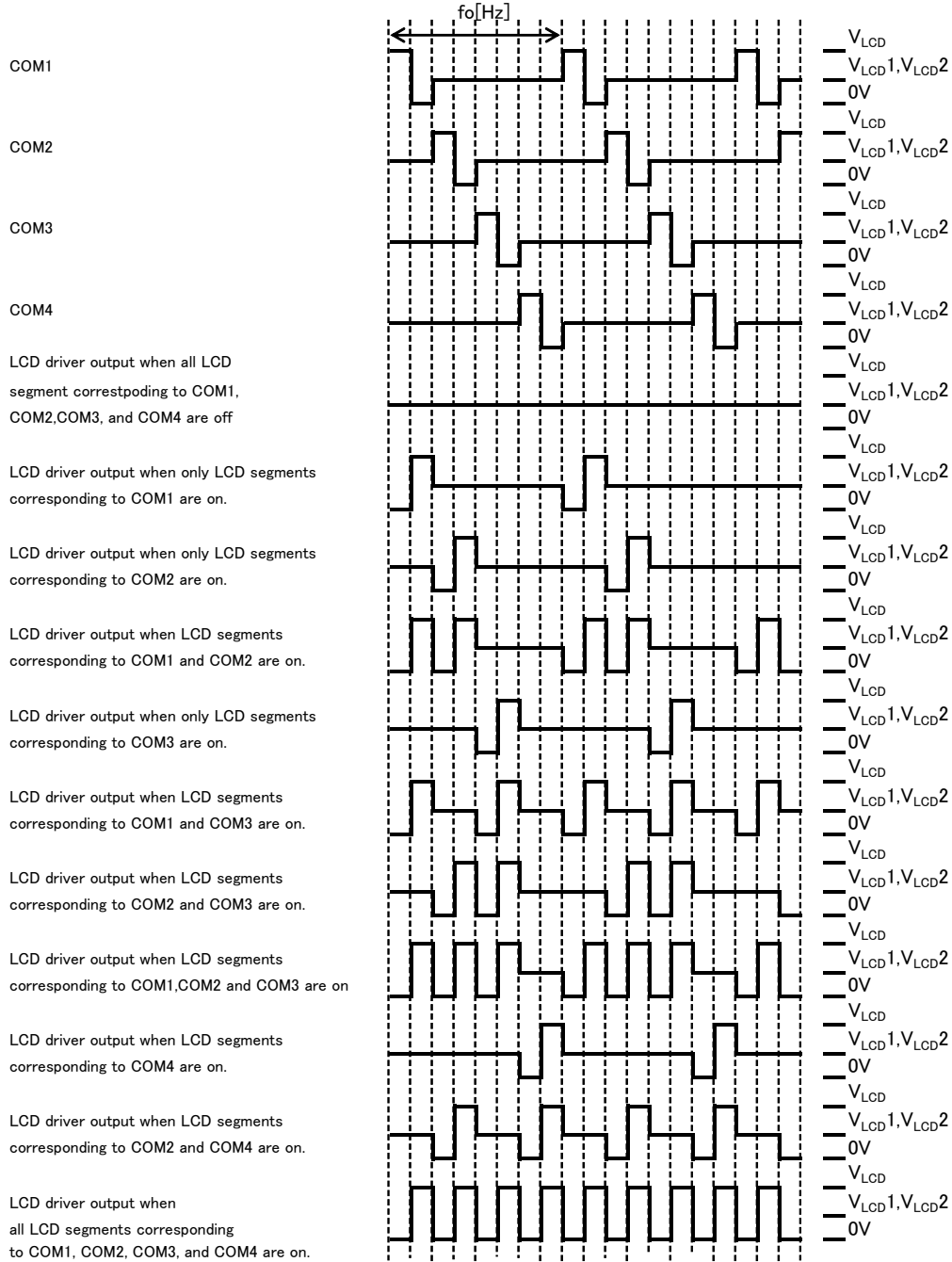

Figure 12. LCD Waveform (1/4-Duty, 1/2-Bias)

Output Waveforms (1/3-Duty 1/3-Bias Drive Scheme)

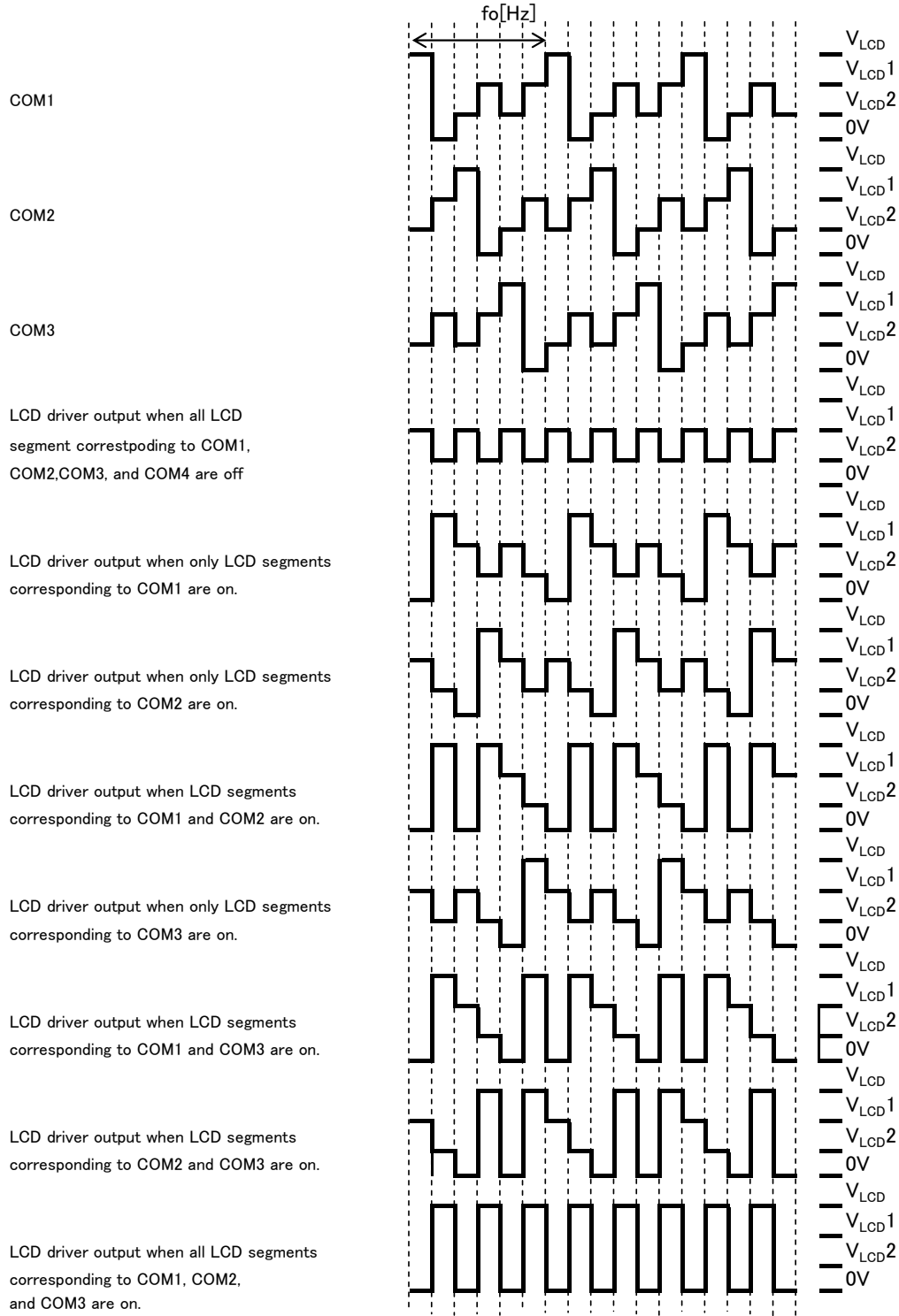

Figure 13. LCD Waveform (1/3-Duty, 1/3-Bias)

※COM4 function is same as COM1 at 1/3-Duty.

Output Waveforms (1/3-Duty 1/2-Bias Drive Scheme)

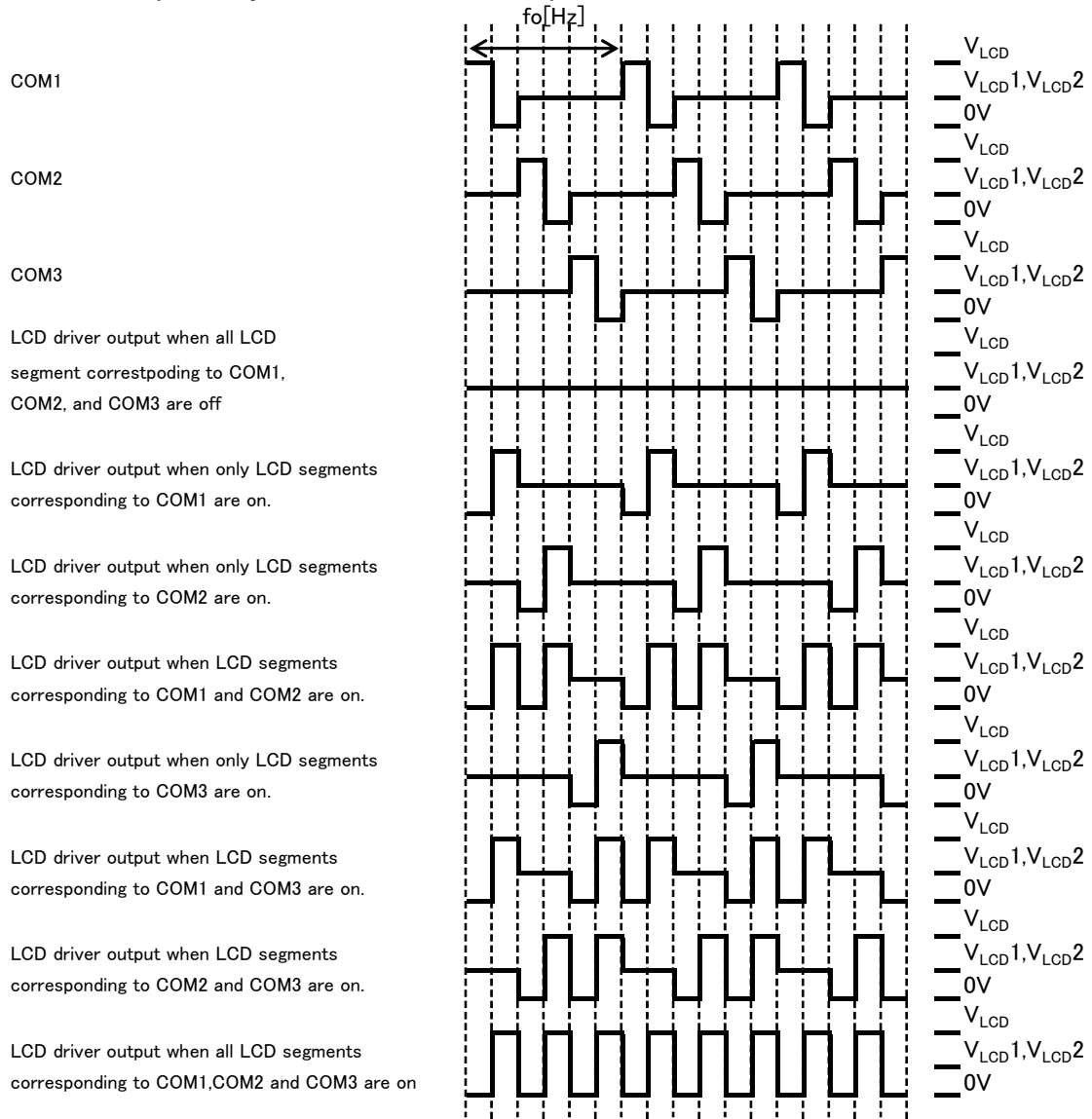

Figure 14. LCD Waveform (1/3-Duty, 1/2-Bias)

※COM4 function is same as COM1 at 1/3-Duty.

The INHb pin and Display Control

Since the IC internal data (1/4-Duty: the display data D1 to D216 and the control data, 1/3-Duty: the display data D1 to D162 and the control data) is undefined when power is first applied, applications should set the INH pin low at the same time as power is applied to turn off the display (This sets the S1/P1/G1 to S6/P6/G6, S7 to S54, COM1 to COM4 to the VSS level.) and during this period send serial data from the controller. The controller should then set the INH pin high after the data transfer has completed. This procedure prevents meaningless displays at power on.

1. 1/4-Duty

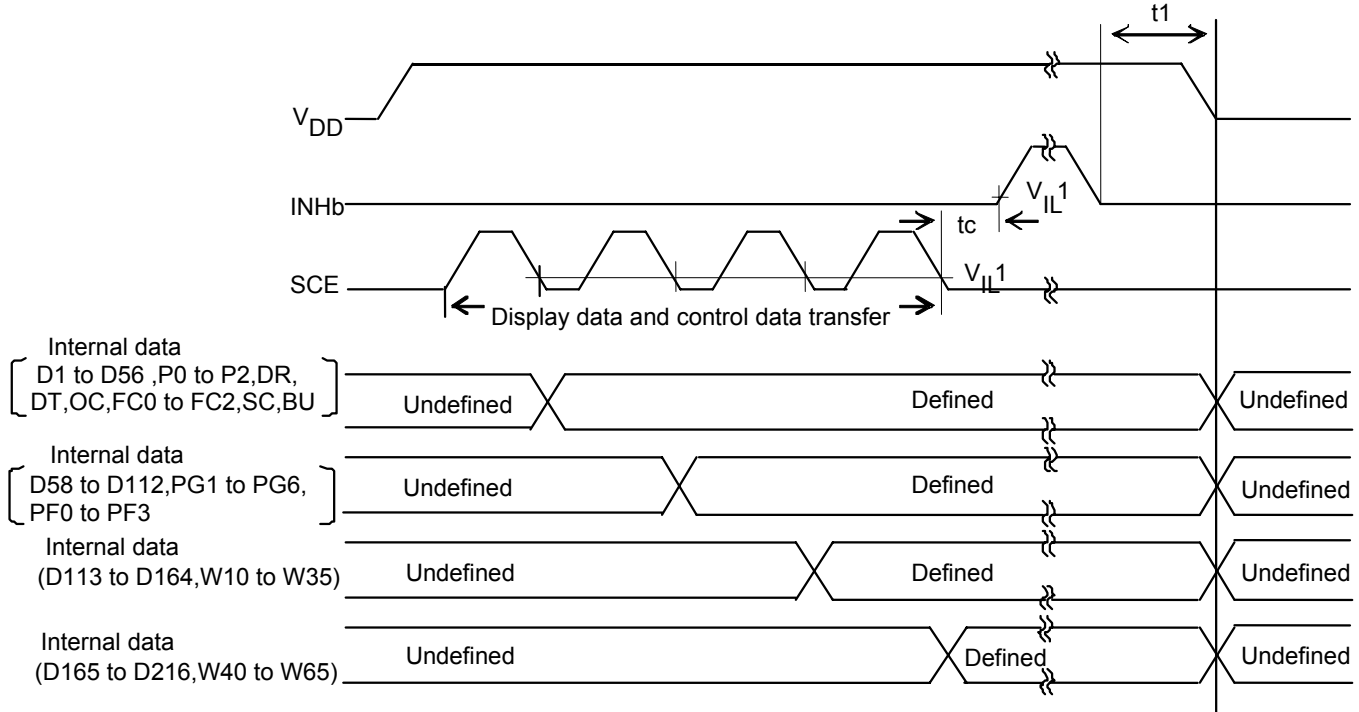

Figure 15. Power ON/OFF and INHb Control Sequence (1/4-Duty)

2. 1/3-Duty

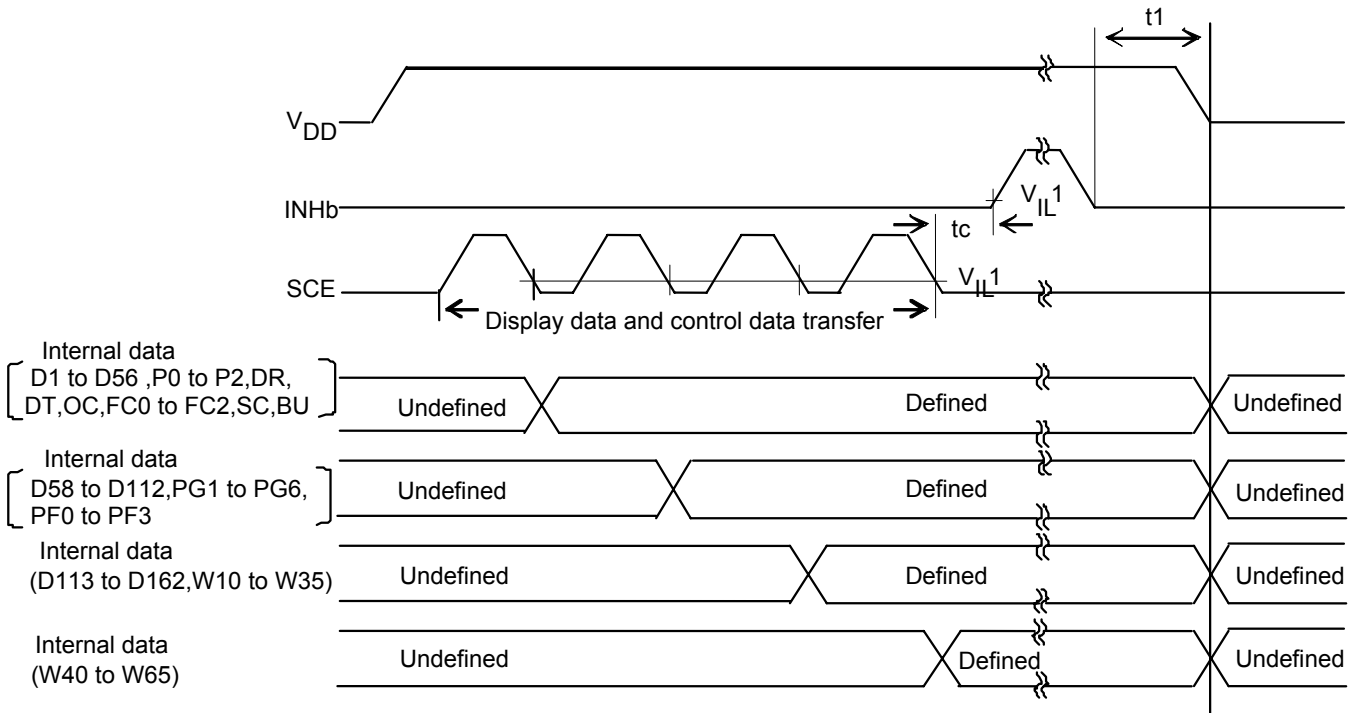

Figure 16. Power ON/OFF and INHb Control Sequence (1/3-Duty)

Note: $t_1 \geq 0$, t_c : min 10us

Oscillation Stabilization Time of the Internal Oscillation Circuit

It must be noted that the oscillation of the internal oscillation circuit is unstable for a maximum of 100µs (oscillation stabilization time) after oscillation has started.

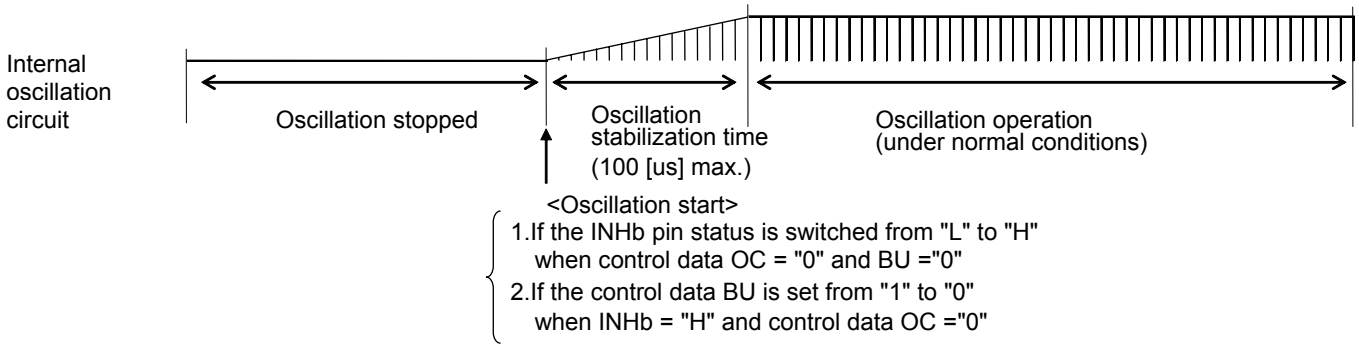

Figure 17. Oscillation Stabilization Time

Voltage Detection Type Reset Circuit (VDET)

The Voltage Detection Type Reset Circuit generates an output signal and resets the system when power is applied for the first time and when voltage drops (that is, for example, the power supply voltage is less than or equal to the power down detection voltage (VDET = 1.8V typ.). To ensure that this reset function works properly, it is recommended that a capacitor must be connected to the power supply line so that both the power supply voltage (VDD) rise time when power is first applied and the power supply voltage (VDD) fall time when the voltage drops are at least 1ms.

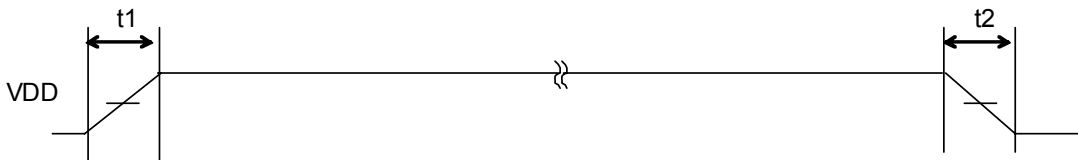

Figure 18. VDET Detection Timing

Power supply voltage VDD rise time: $t1 > 1\text{ms}$
 Power supply voltage VDD fall time: $t2 > 1\text{ms}$

Reset Condition

When BU97510CKV-M is initialized, the internal status after power supply has been reset as the following table.

Table 1. control data reset condition

Instruction	At Reset Condition
S1/P1/G1 to S2/P2/G2 pin	[P0,P1,P2]=[0,0,0]:all segment output
LCD bias	DR=0:1/3-Bias
LCD duty	DT=0:1/4-Duty
DISPLAY frequency	[FC0,FC1,FC2]=[0,0,0]:fosc/6144
Display clock mode	OC=0:Internal oscillator
LCD display	SC=1:OFF
Power mode	BU=1:Power saving mode
PWM/GPO output	PGx=0:PWM output(x=1~6)
PWM frequency	[PF0,PF1,PF2,PF3]=[0,0,0,0]: fosc /2048
PWM duty	[Wn0~Wn5]=[0,0,0,0,0,0] :(1/64)xTp(n=1~6, Tp=1/fp)

Operational Notes

1. Reverse Connection of Power Supply

Connecting the power supply in reverse polarity can damage the IC. Take precautions against reverse polarity when connecting the power supply, such as mounting an external diode between the power supply and the IC's power supply pins.

2. Power Supply Lines

Design the PCB layout pattern to provide low impedance supply lines. Separate the ground and supply lines of the digital and analog blocks to prevent noise in the ground and supply lines of the digital block from affecting the analog block. Furthermore, connect a capacitor to ground at all power supply pins. Consider the effect of temperature and aging on the capacitance value when using electrolytic capacitors.

3. Ground Voltage

Ensure that no pins are at a voltage below that of the ground pin at any time, even during transient condition.

4. Ground Wiring Pattern

When using both small-signal and large-current ground traces, the two ground traces should be routed separately but connected to a single ground at the reference point of the application board to avoid fluctuations in the small-signal ground caused by large currents. Also ensure that the ground traces of external components do not cause variations on the ground voltage. The ground lines must be as short and thick as possible to reduce line impedance.

5. Thermal Consideration

Should by any chance the power dissipation rating be exceeded the rise in temperature of the chip may result in deterioration of the properties of the chip. The absolute maximum rating of the Pd stated in this specification is when the IC is mounted on a 70mm x 70mm x 1.6mm glass epoxy board. In case of exceeding this absolute maximum rating, increase the board size and copper area to prevent exceeding the Pd rating.

6. Recommended Operating Conditions

These conditions represent a range within which the expected characteristics of the IC can be approximately obtained. The electrical characteristics are guaranteed under the conditions of each parameter.

7. Inrush Current

When power is first supplied to the IC, it is possible that the internal logic may be unstable and inrush current may flow instantaneously due to the internal powering sequence and delays, especially if the IC has more than one power supply. Therefore, give special consideration to power coupling capacitance, power wiring, width of ground wiring, and routing of connections.

8. Operation Under Strong Electromagnetic Field

Operating the IC in the presence of a strong electromagnetic field may cause the IC to malfunction.

9. Testing on Application Boards

When testing the IC on an application board, connecting a capacitor directly to a low-impedance output pin may subject the IC to stress. Always discharge capacitors completely after each process or step. The IC's power supply should always be turned off completely before connecting or removing it from the test setup during the inspection process. To prevent damage from static discharge, ground the IC during assembly and use similar precautions during transport and storage.

10. Inter-pin Short and Mounting Errors

Ensure that the direction and position are correct when mounting the IC on the PCB. Incorrect mounting may result in damaging the IC. Avoid nearby pins being shorted to each other especially to ground, power supply and output pin. Inter-pin shorts could be due to many reasons such as metal particles, water droplets (in very humid environment) and unintentional solder bridge deposited in between pins during assembly to name a few.

Operational Notes – continued**11. Unused Input Pins**

Input pins of an IC are often connected to the gate of a MOS transistor. The gate has extremely high impedance and extremely low capacitance. If left unconnected, the electric field from the outside can easily charge it. The small charge acquired in this way is enough to produce a significant effect on the conduction through the transistor and cause unexpected operation of the IC. So unless otherwise specified, unused input pins should be connected to the power supply or ground line.

12. Regarding the Input Pin of the IC

In the construction of this IC, P-N junctions are inevitably formed creating parasitic diodes or transistors. The operation of these parasitic elements can result in mutual interference among circuits, operational faults, or physical damage. Therefore, conditions which cause these parasitic elements to operate, such as applying a voltage to an input pin lower than the ground voltage should be avoided. Furthermore, do not apply a voltage to the input pins when no power supply voltage is applied to the IC. Even if the power supply voltage is applied, make sure that the input pins have voltages within the values specified in the electrical characteristics of this IC.

13. Ceramic Capacitor

When using a ceramic capacitor, determine the dielectric constant considering the change of capacitance with temperature and the decrease in nominal capacitance due to DC bias and others.

14. Data transmission

To refrain from data transmission is strongly recommended while power supply is rising up or falling down to prevent from the occurrence of disturbances on transmission and reception.

Ordering Information

B U 9 7 5 1 0 C K V	-	M E 2
---------------------	---	-------

Part Number

Package
KV : VQFP64

Product Rank
M: for Automotive
Packaging Specification
E2: Embossed tape and reel
(VQFP64)

Marking Diagram

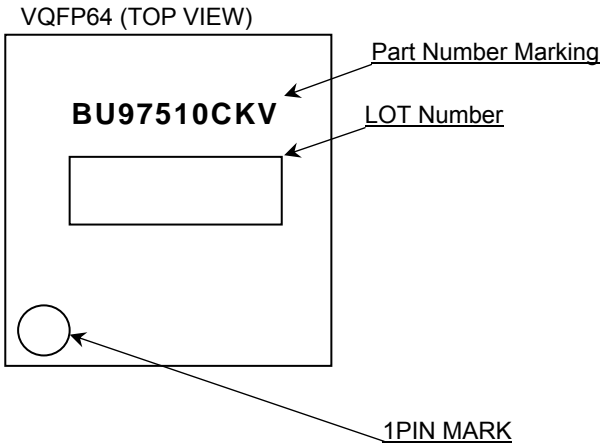

Physical Dimension, Tape and Reel Information

Package Name	VQFP64
--------------	--------

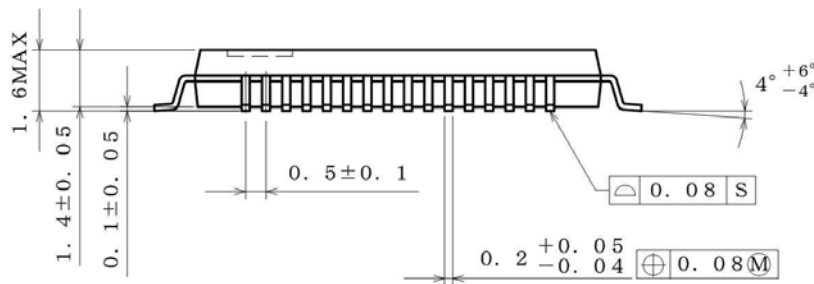
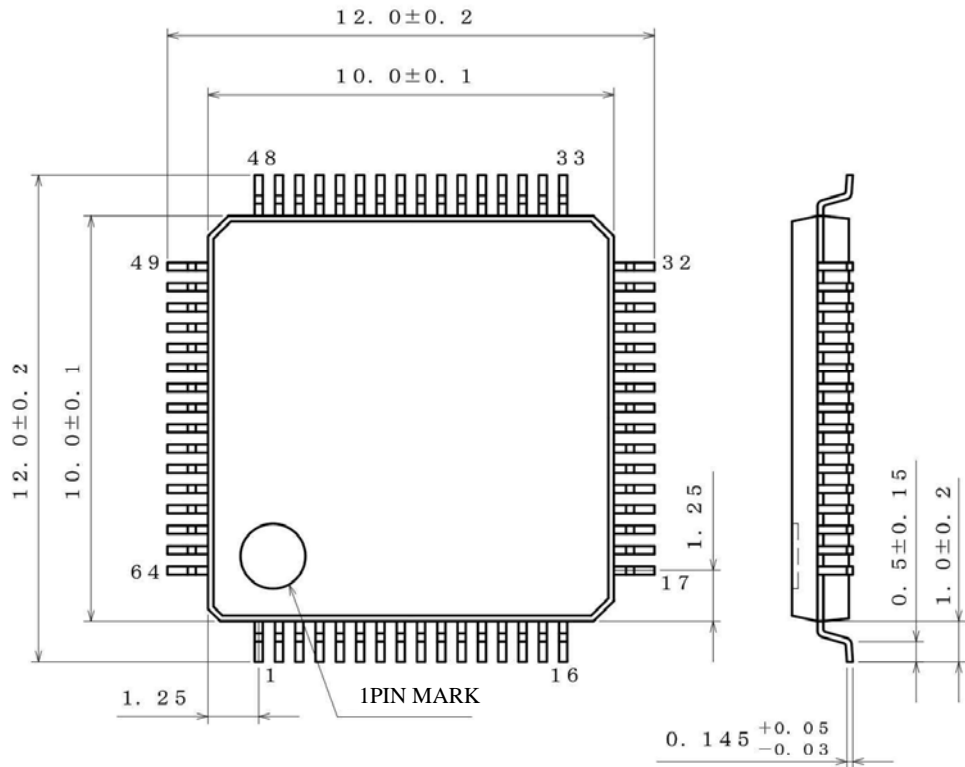

(UNIT : mm)
 PKG : VQFP64
 Drawing: EX252-5001-1

<Tape and Reel information>

Tape	Embossed carrier tape (with dry pack)
Quantity	1000pcs
Direction of feed	E2 (The direction is the 1pin of product is at the upper left when you hold reel on the left hand and you pull out the tape on the right hand)

* Order quantity needs to be multiple of the minimum quantity.

Revision History

Version	Date	Description
001	25.Feb.2014	New Release
002	31.Mar.2014	Change the condition of VIH1 and VIH2 in page 3.
003	02.Apr.2015	Add Note on AEC-Q100 Qualified in page 1. Modify INHb Handling when unused of Pin Description in page 6.

Notice

Precaution on using ROHM Products

1. If you intend to use our Products in devices requiring extremely high reliability (such as medical equipment ^(Note 1), aircraft/spacecraft, nuclear power controllers, etc.) and whose malfunction or failure may cause loss of human life, bodily injury or serious damage to property ("Specific Applications"), please consult with the ROHM sales representative in advance. Unless otherwise agreed in writing by ROHM in advance, ROHM shall not be in any way responsible or liable for any damages, expenses or losses incurred by you or third parties arising from the use of any ROHM's Products for Specific Applications.

(Note1) Medical Equipment Classification of the Specific Applications

JAPAN	USA	EU	CHINA
CLASS III	CLASS III	CLASS II b	CLASS III
CLASS IV		CLASS III	

2. ROHM designs and manufactures its Products subject to strict quality control system. However, semiconductor products can fail or malfunction at a certain rate. Please be sure to implement, at your own responsibilities, adequate safety measures including but not limited to fail-safe design against the physical injury, damage to any property, which a failure or malfunction of our Products may cause. The following are examples of safety measures:
 - [a] Installation of protection circuits or other protective devices to improve system safety
 - [b] Installation of redundant circuits to reduce the impact of single or multiple circuit failure
3. Our Products are not designed under any special or extraordinary environments or conditions, as exemplified below. Accordingly, ROHM shall not be in any way responsible or liable for any damages, expenses or losses arising from the use of any ROHM's Products under any special or extraordinary environments or conditions. If you intend to use our Products under any special or extraordinary environments or conditions (as exemplified below), your independent verification and confirmation of product performance, reliability, etc, prior to use, must be necessary:
 - [a] Use of our Products in any types of liquid, including water, oils, chemicals, and organic solvents
 - [b] Use of our Products outdoors or in places where the Products are exposed to direct sunlight or dust
 - [c] Use of our Products in places where the Products are exposed to sea wind or corrosive gases, including Cl₂, H₂S, NH₃, SO₂, and NO₂
 - [d] Use of our Products in places where the Products are exposed to static electricity or electromagnetic waves
 - [e] Use of our Products in proximity to heat-producing components, plastic cords, or other flammable items
 - [f] Sealing or coating our Products with resin or other coating materials
 - [g] Use of our Products without cleaning residue of flux (even if you use no-clean type fluxes, cleaning residue of flux is recommended); or Washing our Products by using water or water-soluble cleaning agents for cleaning residue after soldering
 - [h] Use of the Products in places subject to dew condensation
4. The Products are not subject to radiation-proof design.
5. Please verify and confirm characteristics of the final or mounted products in using the Products.
6. In particular, if a transient load (a large amount of load applied in a short period of time, such as pulse. is applied, confirmation of performance characteristics after on-board mounting is strongly recommended. Avoid applying power exceeding normal rated power; exceeding the power rating under steady-state loading condition may negatively affect product performance and reliability.
7. De-rate Power Dissipation (Pd) depending on Ambient temperature (Ta). When used in sealed area, confirm the actual ambient temperature.
8. Confirm that operation temperature is within the specified range described in the product specification.
9. ROHM shall not be in any way responsible or liable for failure induced under deviant condition from what is defined in this document.

Precaution for Mounting / Circuit board design

1. When a highly active halogenous (chlorine, bromine, etc.) flux is used, the residue of flux may negatively affect product performance and reliability.
2. In principle, the reflow soldering method must be used on a surface-mount products, the flow soldering method must be used on a through hole mount products. If the flow soldering method is preferred on a surface-mount products, please consult with the ROHM representative in advance.

For details, please refer to ROHM Mounting specification

Precautions Regarding Application Examples and External Circuits

1. If change is made to the constant of an external circuit, please allow a sufficient margin considering variations of the characteristics of the Products and external components, including transient characteristics, as well as static characteristics.
2. You agree that application notes, reference designs, and associated data and information contained in this document are presented only as guidance for Products use. Therefore, in case you use such information, you are solely responsible for it and you must exercise your own independent verification and judgment in the use of such information contained in this document. ROHM shall not be in any way responsible or liable for any damages, expenses or losses incurred by you or third parties arising from the use of such information.

Precaution for Electrostatic

This Product is electrostatic sensitive product, which may be damaged due to electrostatic discharge. Please take proper caution in your manufacturing process and storage so that voltage exceeding the Products maximum rating will not be applied to Products. Please take special care under dry condition (e.g. Grounding of human body / equipment / solder iron, isolation from charged objects, setting of Ionizer, friction prevention and temperature / humidity control).

Precaution for Storage / Transportation

1. Product performance and soldered connections may deteriorate if the Products are stored in the places where:
 - [a] the Products are exposed to sea winds or corrosive gases, including Cl₂, H₂S, NH₃, SO₂, and NO₂
 - [b] the temperature or humidity exceeds those recommended by ROHM
 - [c] the Products are exposed to direct sunshine or condensation
 - [d] the Products are exposed to high Electrostatic
2. Even under ROHM recommended storage condition, solderability of products out of recommended storage time period may be degraded. It is strongly recommended to confirm solderability before using Products of which storage time is exceeding the recommended storage time period.
3. Store / transport cartons in the correct direction, which is indicated on a carton with a symbol. Otherwise bent leads may occur due to excessive stress applied when dropping of a carton.
4. Use Products within the specified time after opening a humidity barrier bag. Baking is required before using Products of which storage time is exceeding the recommended storage time period.

Precaution for Product Label

QR code printed on ROHM Products label is for ROHM's internal use only.

Precaution for Disposition

When disposing Products please dispose them properly using an authorized industry waste company.

Precaution for Foreign Exchange and Foreign Trade act

Since concerned goods might be fallen under listed items of export control prescribed by Foreign exchange and Foreign trade act, please consult with ROHM in case of export.

Precaution Regarding Intellectual Property Rights

1. All information and data including but not limited to application example contained in this document is for reference only. ROHM does not warrant that foregoing information or data will not infringe any intellectual property rights or any other rights of any third party regarding such information or data.
2. ROHM shall not have any obligations where the claims, actions or demands arising from the combination of the Products with other articles such as components, circuits, systems or external equipment (including software).
3. No license, expressly or implied, is granted hereby under any intellectual property rights or other rights of ROHM or any third parties with respect to the Products or the information contained in this document. Provided, however, that ROHM will not assert its intellectual property rights or other rights against you or your customers to the extent necessary to manufacture or sell products containing the Products, subject to the terms and conditions herein.

Other Precaution

1. This document may not be reprinted or reproduced, in whole or in part, without prior written consent of ROHM.
2. The Products may not be disassembled, converted, modified, reproduced or otherwise changed without prior written consent of ROHM.
3. In no event shall you use in any way whatsoever the Products and the related technical information contained in the Products or this document for any military purposes, including but not limited to, the development of mass-destruction weapons.
4. The proper names of companies or products described in this document are trademarks or registered trademarks of ROHM, its affiliated companies or third parties.

General Precaution

1. Before you use our Products, you are requested to carefully read this document and fully understand its contents. ROHM shall not be in any way responsible or liable for failure, malfunction or accident arising from the use of any ROHM's Products against warning, caution or note contained in this document.
2. All information contained in this document is current as of the issuing date and subject to change without any prior notice. Before purchasing or using ROHM's Products, please confirm the latest information with a ROHM sales representative.
3. The information contained in this document is provided on an "as is" basis and ROHM does not warrant that all information contained in this document is accurate and/or error-free. ROHM shall not be in any way responsible or liable for any damages, expenses or losses incurred by you or third parties resulting from inaccuracy or errors of or concerning such information.



Компания «ЭлектроПласт» предлагает заключение долгосрочных отношений при поставках импортных электронных компонентов на взаимовыгодных условиях!

Наши преимущества:

- Оперативные поставки широкого спектра электронных компонентов отечественного и импортного производства напрямую от производителей и с крупнейших мировых складов;
- Поставка более 17-ти миллионов наименований электронных компонентов;
- Поставка сложных, дефицитных, либо снятых с производства позиций;
- Оперативные сроки поставки под заказ (от 5 рабочих дней);
- Экспресс доставка в любую точку России;
- Техническая поддержка проекта, помощь в подборе аналогов, поставка прототипов;
- Система менеджмента качества сертифицирована по Международному стандарту ISO 9001;
- Лицензия ФСБ на осуществление работ с использованием сведений, составляющих государственную тайну;
- Поставка специализированных компонентов (Xilinx, Altera, Analog Devices, Intersil, Interpoint, Microsemi, Aeroflex, Peregrine, Syfer, Eurofarad, Texas Instrument, Miteq, Cobham, E2V, MA-COM, Hittite, Mini-Circuits, General Dynamics и др.);

Помимо этого, одним из направлений компании «ЭлектроПласт» является направление «Источники питания». Мы предлагаем Вам помощь Конструкторского отдела:

- Подбор оптимального решения, техническое обоснование при выборе компонента;
- Подбор аналогов;
- Консультации по применению компонента;
- Поставка образцов и прототипов;
- Техническая поддержка проекта;
- Защита от снятия компонента с производства.



Как с нами связаться

Телефон: 8 (812) 309 58 32 (многоканальный)

Факс: 8 (812) 320-02-42

Электронная почта: org@eplast1.ru

Адрес: 198099, г. Санкт-Петербург, ул. Калинина, дом 2, корпус 4, литера А.