

REVISIONS			
REV	ECN, ERN NO.	DATE	APPRD.
A	PRODUCT DRAWING	DEC01/05	K.L.

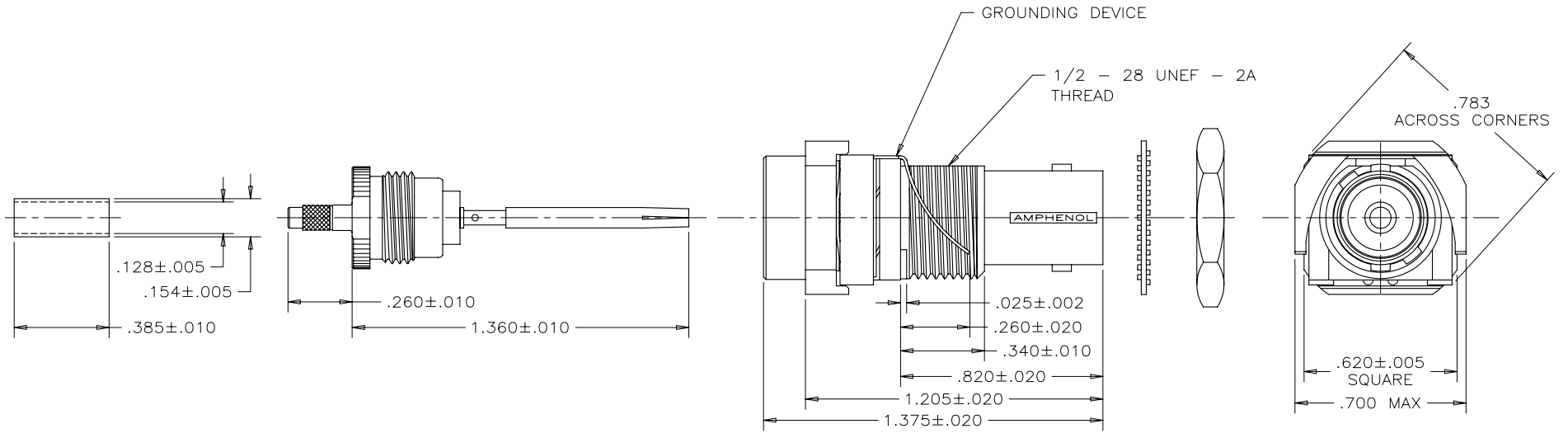

- MECHANICAL:** ALL MATERIALS ARE RoHS COMPLIANT
- THREADED HOUSING:** THERMOPLASTIC (COMPLIES WITH UL FLAMMABILITY REQUIREMENT OF 94V-0 PER UL-STD-94)
- GROUNDING DEVICE:** COPPER ALLOY, NICKEL PLATED
- METAL BODY:** HIGH STRENGTH ZINC DIECAST (NICKEL PLATED)
- CENTER CONTACT:** PHOSPHOR BRONZE, 30 MICROINCH, GOLD PLATED
- MOUNTING NUT:** BRASS, NICKEL PLATED

RECOMMENDED CABLE (RG-179)
STRIPPING DIM'S
CABLE IMPEDANCE: 75 OHM

RECOMMENDED PANEL CUTOUT

CRIMP WITH AMPHENOL TOOL 227-944 (M22520/5-01)
 AND DIE SET 227-1221-03 CAVITY 'A' (M22520/5-03)

ELECTRICAL SPECIFICATION:

AMPHENOL PART NO.	456E-218	456E-218S	456E-218SL*
CAPACITANCE	10000 pF ± 15%	10000 pF ± 15%	
DIELECTRIC WITHSTANDING VOLTAGE	1000 VDC	1050/700 VDC BREAK BY SPARK GAP DEVICE	
	500 V RMS		
WORKING VOLTAGE	200 VDC	200 VDC	
IMPEDANCE	75 OHM NOMINAL	75 OHM NOMINAL	
OPERATING TEMPERATURE	-20°C TO +85°C	-20°C TO +85°C	

* SEE SHEET 2 FOR PART NO. 456E-218SL.

THIS DOCUMENT CONTAINS PROPRIETARY INFORMATION AND SUCH INFORMATION MAY NOT BE DISCLOSED TO OTHERS FOR ANY PURPOSE OR USED FOR MANUFACTURING PURPOSES WITHOUT WRITTEN PERMISSION FROM AMPHENOL CANADA CORP.

DRAWN S.BUENAVIDES	DATE DEC01/05	Amphenol Canada Corp.	
CHECKED K.LAMBIE	DATE DEC02/05		
DESIGNED		TITLE 456E SERIES B.N.C. REAR MOUNT CAPACITIVELY DECOUPLED CONNECTOR, 10,000 pF, 75 OHM, CRIMP, RoHS COMPLIANT	
APPROVED		DWG C	DRAWING NO. P-456E-218XX
INDUSTRIAL ENG. APPRD.		SCALE 3/1	WT. -----
ENGINEERING RELEASE NO.		SURF. -----	SHEET 1 OF 3
REF.			
DIMENSIONS ARE IN INCHES	CODE IDENT. NO. 03554		

REVISIONS			
REV	ECN, ERN NO.	DATE	APPRD.
A	PRODUCT DRAWING	DEC01/05	K.L.

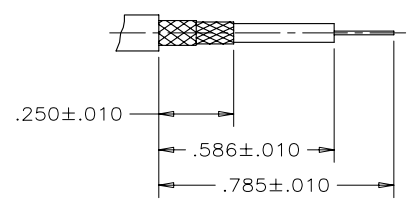
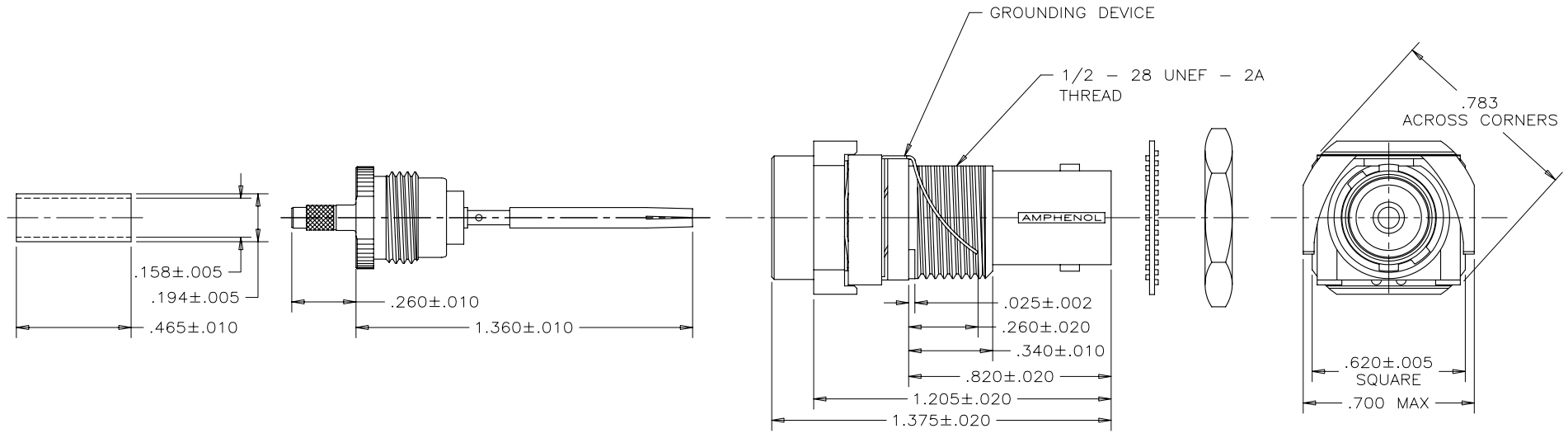

RECOMMENDED CABLE (RD-179)
 STRIPPING DIM'S
 CABLE IMPEDANCE: 75 OHM

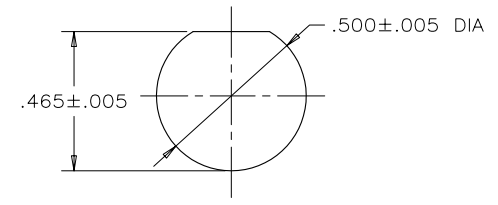

RECOMMENDED PANEL CUTOUT

CRIMP WITH AMPHENOL TOOL 227-944 (M22520/5-01)
 AND DIE SET 227-980-2 CAVITY 'A'

AMPHENOL PART NO.: 456E-218SL
 SEE SHEET 1 FOR MECHANICAL AND ELECTRICAL SPECIFICATIONS.

THIS DOCUMENT CONTAINS PROPRIETARY INFORMATION AND SUCH INFORMATION
 MAY NOT BE DISCLOSED TO OTHERS FOR ANY PURPOSE OR USED FOR MANUFACTURING
 PURPOSES WITHOUT WRITTEN PERMISSION FROM AMPHENOL CANADA CORP.

DRAWN	S.BUENAVIDES	DATE	DEC01/05	Amphenol Canada Corp.	
CHECKED	K.LAMBIE	DATE	DEC02/05		
DESIGNED				TITLE	456E SERIES B.N.C. REAR MOUNT CAPACITIVELY DECOUPLED CONNECTOR, 10,000 pF, 75 OHM, CRIMP, RoHS COMPLIANT
APPROVED				DWG	DRAWING NO. P-456E-218XX
INDUSTRIAL ENG. APPRD.				SCALE	3/1
ENGINEERING RELEASE NO.				WT.	
REF.				SURF.	
DIMENSIONS ARE IN	INCHES	CODE IDENT. NO.	03554	SHEET	2 OF 3
				REV.	A

ASSEMBLY INSTRUCTIONS FOR P/N 456E-218 & 456E-218S

REVISIONS			
REV	ECN, ERN NO.	DATE	APPRD.
A	PRODUCT DRAWING	DEC01/05	K.L.

OUTER FERRULE

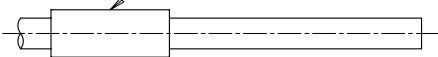

STEP 1
SLIDE OUTER FERRULE ONTO CABLE AS SHOWN PRIOR TO STRIPPING CABLE.



STEP 2
STRIP CABLE JACKET, BRAID AND DIELECTRIC TO DIMENSIONS SHOWN ON SHEET 1. ALL CUTS ARE TO BE SHARP AND SQUARE. IMPORTANT: DO NOT NICK BRAID, DIELECTRIC AND CENTRE CONDUCTOR WHEN CUTTING. TIN CENTRE CONDUCTOR USING SOFT SOLDER PER QQ-S-571 COMP Sn 60. AVOID EXCESSIVE HEAT WHILE TINNING TO PREVENT SWELLING OF CABLE DIELECTRIC.



STEP 3
SLIGHTLY FLARE OUT END OF CABLE BRAID AS SHOWN SO AS TO FACILITATE INSERTION ONTO CENTRE CONTACT SUB-ASSEMBLY. IMPORTANT: DO NOT COMB OUT BRAID.

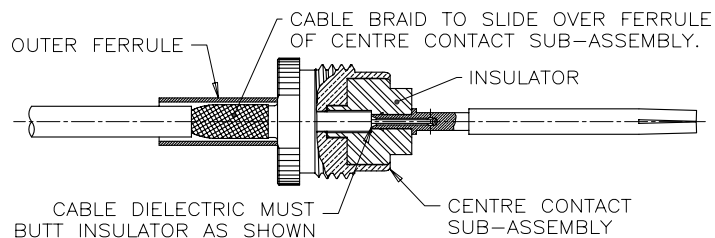

STEP 4
INSTALL CENTRE CONTACT SUB-ASSEMBLY ONTO CABLE SO THAT FERRULE PORTION SLIDES UNDER BRAID AND INSULATOR BUTTS FLUSH AGAINST CABLE DIELECTRIC. SLIDE OUTER FERRULE OVER BRAID AND UP AGAINST SHOULDER OF CENTRE CONTACT SUB-ASSEMBLY. MAKE SURE NO SLACK EXISTS IN BRAID. CRIMP OUTER FERRULE WITH TOOL SPECIFIED ON SHEET 1, KEEPING CABLE DIELECTRIC BOTTOMED AGAINST INSULATOR.

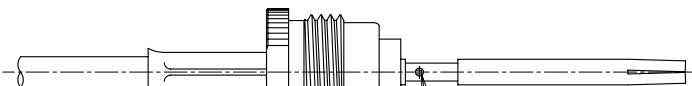

STEP 5
SOFT SOLDER CENTRE CONDUCTOR TO CONTACT USING ROSIN CORE PER QQ-S-571 COMP Sn 60. DO NOT GET ANY SOLDER ON OUTSIDE SURFACES OF CONTACT.

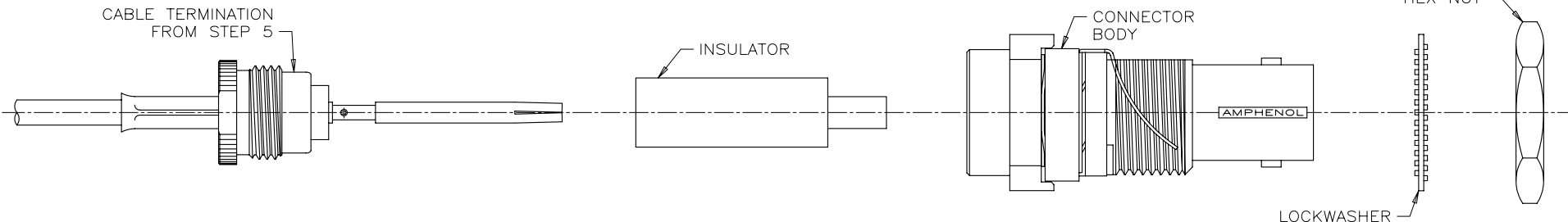

STEP 6
SLIDE INSULATOR INTO CONNECTOR BODY AND SCREW THE ASSEMBLY ONTO THE PREPARED CABLE TERMINATION. WRENCH TIGHTEN BY HOLDING THE CENTRE CONTACT SUB-ASSEMBLY STATIONARY WHILE ROTATING THE CONNECTOR BODY. SLIDE CONNECTOR INTO THE PANEL OPENING AND INSTALL LOCKWASHER AND HEX NUT TO HOLD IT IN PLACE.

MATERIAL	DRAWN S.BUENAVIDES	DATE DEC01/05
---	CHECKED K.LAMBIE	DEC02/05
FINISH	DESIGNED	
---	APPROVED	
	INDUSTRIAL ENG. APPRD.	
	ENGINEERING RELEASE NO.	
	REF.	
	DIMENSIONS ARE IN	CODE IDENT. NO.
	INCHES	0.3554

Amphenol Canada Corp.		
TITLE 456E SERIES B.N.C. REAR MOUNT CAPACITIVELY DECOUPLED CONNECTOR, 10,000 pF, 75 OHM, CRIMP, RoHS COMPLIANT		
DWG C	DRAWING NO. P-456E-218XX	REV. A
SCALE 3/1	WT. -----	SURF. -----
SHEET 3 OF 3		

THIS DOCUMENT CONTAINS PROPRIETARY INFORMATION AND SUCH INFORMATION MAY NOT BE DISCLOSED TO OTHERS FOR ANY PURPOSE OR USED FOR MANUFACTURING PURPOSES WITHOUT WRITTEN PERMISSION FROM AMPHENOL CANADA CORP.



Компания «ЭлектроПласт» предлагает заключение долгосрочных отношений при поставках импортных электронных компонентов на взаимовыгодных условиях!

Наши преимущества:

- Оперативные поставки широкого спектра электронных компонентов отечественного и импортного производства напрямую от производителей и с крупнейших мировых складов;
- Поставка более 17-ти миллионов наименований электронных компонентов;
- Поставка сложных, дефицитных, либо снятых с производства позиций;
- Оперативные сроки поставки под заказ (от 5 рабочих дней);
- Экспресс доставка в любую точку России;
- Техническая поддержка проекта, помощь в подборе аналогов, поставка прототипов;
- Система менеджмента качества сертифицирована по Международному стандарту ISO 9001;
- Лицензия ФСБ на осуществление работ с использованием сведений, составляющих государственную тайну;
- Поставка специализированных компонентов (Xilinx, Altera, Analog Devices, Intersil, Interpoint, Microsemi, Aeroflex, Peregrine, Syfer, Eurofarad, Texas Instrument, Miteq, Cobham, E2V, MA-COM, Hittite, Mini-Circuits, General Dynamics и др.);

Помимо этого, одним из направлений компании «ЭлектроПласт» является направление «Источники питания». Мы предлагаем Вам помощь Конструкторского отдела:

- Подбор оптимального решения, техническое обоснование при выборе компонента;
- Подбор аналогов;
- Консультации по применению компонента;
- Поставка образцов и прототипов;
- Техническая поддержка проекта;
- Защита от снятия компонента с производства.



Как с нами связаться

Телефон: 8 (812) 309 58 32 (многоканальный)

Факс: 8 (812) 320-02-42

Электронная почта: org@eplast1.ru

Адрес: 198099, г. Санкт-Петербург, ул. Калинина, дом 2, корпус 4, литера А.