

NHD-160128WG-BTMI-VZ#-1

Graphic Liquid Crystal Display Module

| | |
|---------|---|
| NHD- | Newhaven Display |
| 160128- | 160 x 128 pixels |
| WG- | Display Type: Graphic |
| B- | Model |
| T- | White LED backlight |
| M- | STN- Blue (-) |
| I- | Transmissive, 6:00 View, Wide Temperature (-20°C ~ +70°C) |
| VZ- | Built-in Negative Voltage |
| #-1 | Selectable Font size (Default: 7 x 8 Font) |

RoHS Compliant

Newhaven Display International, Inc.

2511 Technology Drive, Suite 101

Elgin IL, 60124

Ph: 847-844-8795

Fax: 847-844-8796

www.newhavendisplay.com

nhtech@newhavendisplay.com

nhsales@newhavendisplay.com

Document Revision History

| Revision | Date | Description | Changed by |
|----------|-----------|---|------------|
| 0 | 3/16/2010 | Initial Release | - |
| 1 | 4/13/2010 | User guide reformat | BE |
| 2 | 4/21/2010 | Block diagram update | BE |
| 3 | 5/14/2010 | Updated Input and Output Voltages in Electrical Characteristics | MC |

Functions and Features

- 160 x 128 pixels
- Built-in RA6963 Controller
- +5.0V power supply
- 1/128 duty
- RoHS Compliant

Mechanical Drawing

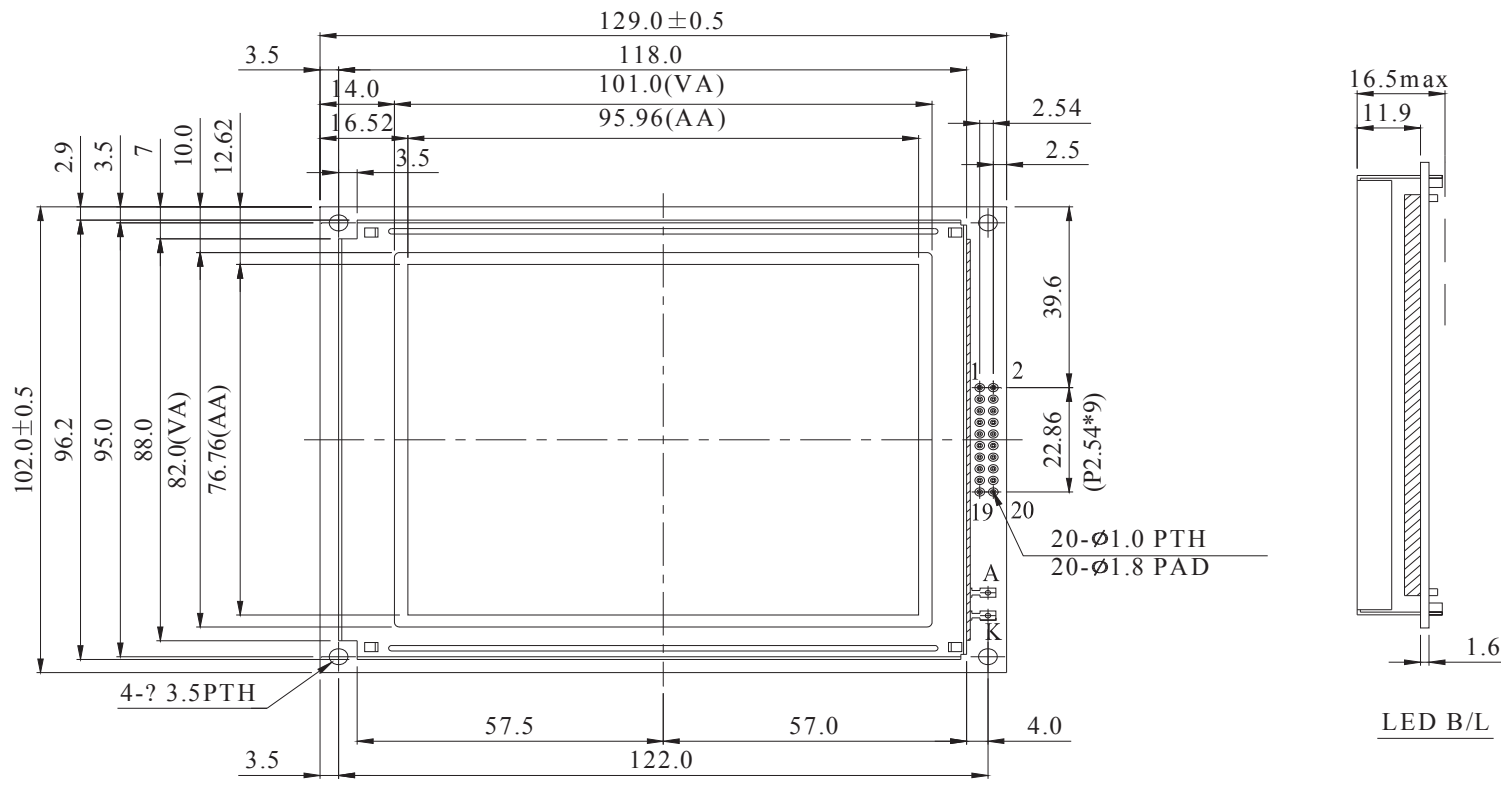

| PIN NO. | SYMBOL |
|---------|--------------------|
| 1 | FG |
| 2 | V _{SS} |
| 3 | V _{DD} |
| 4 | V _O |
| 5 | V _{EE} |
| 6 | \overline{WR} |
| 7 | \overline{RD} |
| 8 | \overline{CE} |
| 9 | C/ \overline{D} |
| 10 | \overline{HALT} |
| 11 | \overline{RESET} |
| 12 | DB0 |
| 13 | DB1 |
| 14 | DB2 |
| 15 | DB3 |
| 16 | DB4 |
| 17 | DB5 |
| 18 | DB6 |
| 19 | DB7 |
| 20 | NC |

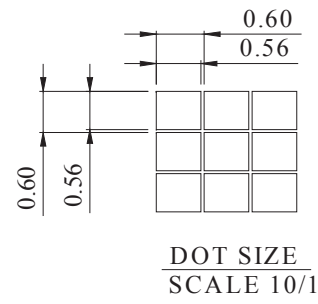

The non-specified tolerance of dimension is ±0.3mm.

Newhaven Display

NHD-160128WG-BTMI-VZ#-1

Pin Description and Wiring Diagram

| Pin No. | Symbol | External Connection | Function Description |
|---------|---------|---------------------|--|
| 1 | FG | Power Supply | Frame Ground |
| 2 | VSS | Power Supply | Ground |
| 3 | VDD | Power Supply | Power supply for Logic (+5.0V) |
| 4 | V0 | Adj. Power Supply | Power supply for contrast (approx. -14.2V) |
| 5 | VEE | Power Supply | Negative voltage output (-16.0V) |
| 6 | /WR | MPU | Active LOW Write signal |
| 7 | /RD | MPU | Active LOW Read signal |
| 8 | /CE | MPU | Active LOW Chip Select signal. |
| 9 | C/D | MPU | Register select signal. C/D=1: Command C/D=0: Data |
| 10 | /HALT | - | Active LOW Clock operating stop signal |
| 11 | /RESET | MPU | Active LOW Reset signal |
| 12-19 | DB0-DB7 | MPU | This is an 8-bit Bi-directional data bus |
| 20 | NC | - | No Connect |
| A | LED+ | Power Supply | Power for LED backlight (+3.5V) |
| K | LED- | Power Supply | Ground for Backlight |

Recommended LCD connector: 2.54mm pitch pins

Backlight connector: - **Mates with:** -

Font Size Jumper Settings:

| Font Size | JF0H | JF0L | JF1H | JF1L |
|--------------------|-------|-------|-------|-------|
| 5 x 8 | Short | Open | Short | Open |
| 6 x 8 | Open | Short | Short | Open |
| 7 x 8 (Default) | Short | Open | Open | Short |
| 8 x 8 | Open | Short | Open | Short |

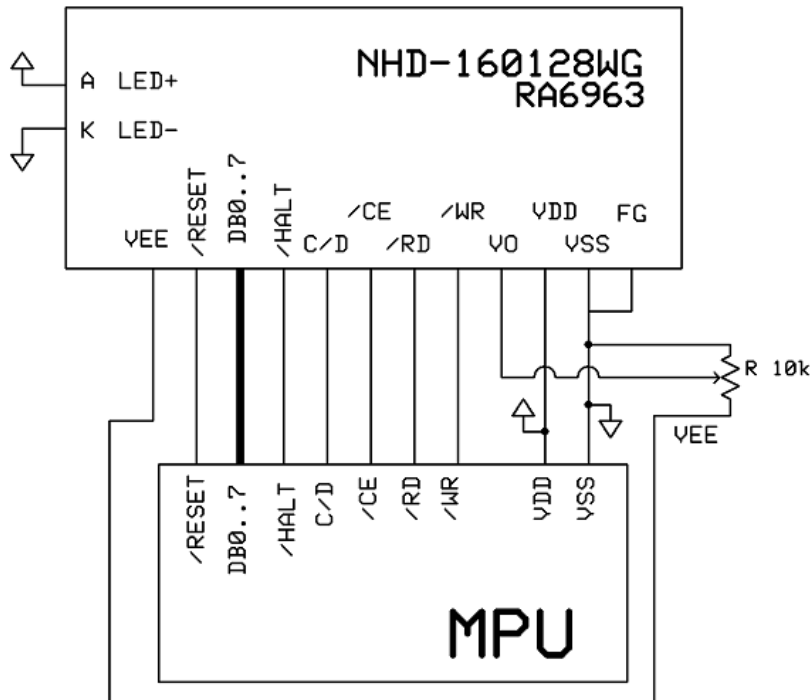

Electrical Characteristics

| Item | Symbol | Condition | Min. | Typ. | Max. | Unit |
|-----------------------------|--------|------------------|---------|--------|------|------|
| Operating Temperature Range | Top | Absolute Max | -20 | - | +70 | °C |
| Storage Temperature Range | Tst | Absolute Max | -30 | - | +80 | °C |
| Supply Voltage | VDD | | 4.5 | 5.0 | 5.5 | V |
| Supply Current | IDD | Ta=25°, VDD=5.0V | 30 | 42 | 50 | mA |
| Supply for LCD (contrast) | VDD-V0 | Ta=25° | 18.8 | 19.2 | 19.6 | V |
| "H" Level input | Vih | | VDD-2.2 | - | VDD | V |
| "L" Level input | Vil | | 0 | - | 0.8 | V |
| "H" Level output | Voh | | VDD-0.3 | - | VDD | V |
| "L" Level output | Vol | | 0 | - | 0.3 | V |
| | | | | | | |
| Backlight Supply Voltage | Vled | | 3.4 | 3.5 | 3.6 | V |
| Backlight Supply Current | Iled | Vled=3.5V | 115.2 | 128 | 200 | mA |
| Backlight Lifetime | - | Iled=128mA | - | 50,000 | - | Hrs. |

Optical Characteristics

| Item | Symbol | Condition | Min. | Typ. | Max. | Unit |
|------------------------------------|--------|-----------|------|------|------|------|
| Viewing Angle - Vertical (top) | AH | Cr ≥ 2 | - | 20 | - | ° |
| Viewing Angle- Vertical (bottom) | AH | Cr ≥ 2 | - | 40 | - | ° |
| Viewing Angle- Horizontal (left) | AV | Cr ≥ 2 | - | 30 | - | ° |
| Viewing Angle - Horizontal (right) | AV | Cr ≥ 2 | - | 30 | - | ° |
| Contrast Ratio | Cr | | | 3 | | |
| Response Time (rise) | Tr | | | 200 | 300 | ms |
| Response Time (fall) | Tf | | | 200 | 300 | ms |

Controller Information

Built-in RA6963. Download specification at http://www.newhavendisplay.com/app_notes/RA6963.pdf

Table of Commands

| Command | Code | D1 | D2 | Function |
|------------------------------|----------|-------------|--------------|---------------------------------|
| Registers Setting | 00100001 | X address | Y address | Set cursor pointer |
| | 00100010 | Data | 00h | Set Offset Register |
| | 00100100 | Low address | High address | Set Address pointer |
| Set Control Word | 01000000 | Low address | High address | Set Text Home Address |
| | 01000001 | Columns | 00h | Set Text Area |
| | 01000010 | Low address | High address | Set Graphic Home Address |
| | 01000011 | Columns | 00h | Set Graphic Area |
| Mode Set | 1000X000 | -- | -- | OR mode |
| | 1000X001 | -- | -- | EXOR mode |
| | 1000X011 | -- | -- | AND mode |
| | 1000X100 | -- | -- | Text Attribute mode |
| | 10000XXX | -- | -- | Internal CG ROM mode |
| | 10001XXX | -- | -- | External CG RAM mode |
| Display Mode | 10010000 | -- | -- | Display off |
| | 1001XX10 | -- | -- | Cursor on, blink off |
| | 1001XX11 | -- | -- | Cursor on, blink on |
| | 100101XX | -- | -- | Text on, graphic off |
| | 100110XX | -- | -- | Text off, graphic on |
| | 100111XX | -- | -- | Text on, graphic on |
| Cursor Pattern Select | 10100000 | -- | -- | 1-line cursor |
| | 10100001 | -- | -- | 2-line cursor |
| | 10100010 | -- | -- | 3-line cursor |
| | 10100011 | -- | -- | 4-line cursor |
| | 10100100 | -- | -- | 5-line cursor |
| | 10100101 | -- | -- | 6-line cursor |
| | 10100110 | -- | -- | 7-line cursor |
| | 10100111 | -- | -- | 8-line cursor |
| Data Read/Write | 11000000 | Data | -- | Data Write and Increment ADP |
| | 11000001 | -- | -- | Data Read and Increment ADP |
| | 11000010 | Data | -- | Data Write and Decrement ADP |
| | 11000011 | -- | -- | Data Read and Decrement ADP |
| | 11000100 | Data | -- | Data Write and Non-variable ADP |
| | 11000101 | -- | -- | Data Read and Non-variable ADP |
| Data auto Read/Write | 10110000 | -- | -- | Set Data Auto Write |
| | 10110001 | -- | -- | Set Data Auto Read |
| | 10110010 | -- | -- | Auto Reset |
| Screen Peek | 11100000 | -- | -- | Screen Peek |
| Screen Copy | 11101000 | | | Screen Copy |
| Bit Set/Reset | 11110XXX | -- | -- | Bit Reset |
| | 11111XXX | -- | -- | Bit Set |
| | 1111X000 | -- | -- | Bit 0 (LSB) |
| | 1111X001 | -- | -- | Bit 1 |
| | 1111X010 | -- | -- | Bit 2 |
| | 1111X011 | -- | -- | Bit 3 |
| | 1111X100 | -- | -- | Bit 4 |
| | 1111X101 | -- | -- | Bit 5 |
| | 1111X110 | -- | -- | Bit 6 |
| | 1111X111 | -- | -- | Bit 7 (MSB) |
| Screen Reverse | 11010000 | Data | -- | Whole screen reverse |

Timing Characteristics

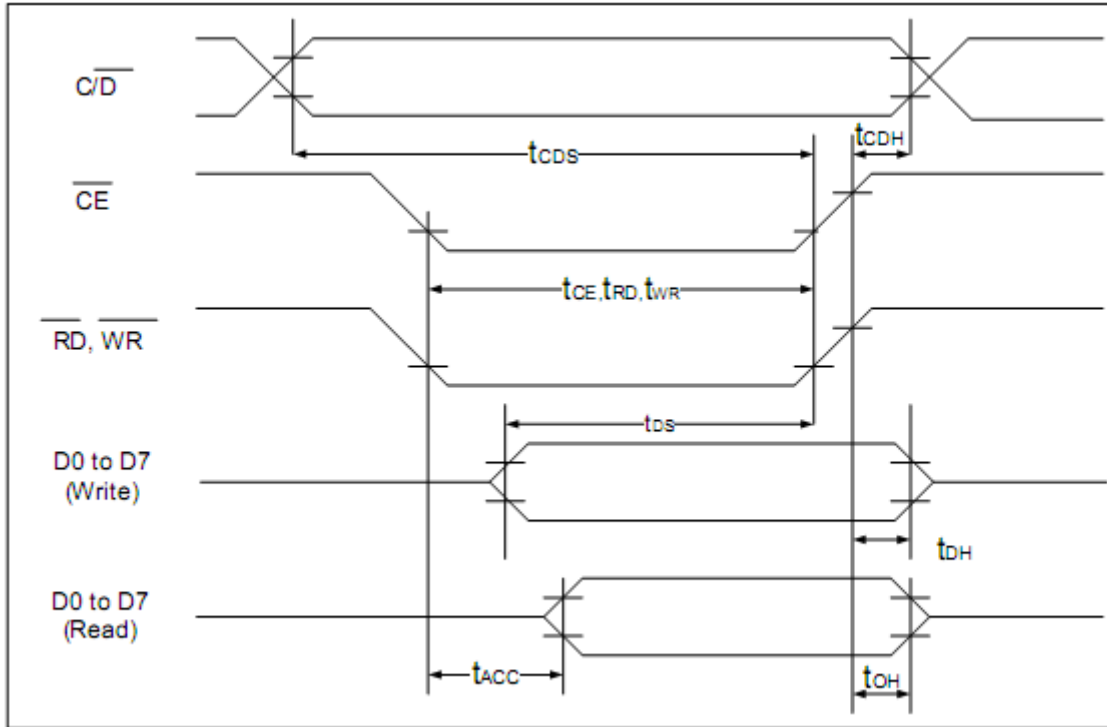

($V_{DD}=+5V\pm 5\%$, $GND=0V$, $T_a = -20$ to $+70^\circ\text{C}$)

| Item | Symbol | Test Conditions | Min. | Max. | Unit |
|---|--------------------------|-----------------|------|------|------|
| $\overline{C/D}$ Set Up Time | t_{CDS} | -- | 100 | -- | ns |
| $\overline{C/D}$ Hold Time | t_{CDH} | -- | 10 | -- | ns |
| \overline{CE} , \overline{RD} , \overline{WR} Pulse Width | t_{CE}, t_{RD}, t_{WR} | -- | 80 | -- | ns |
| Data Set Up Time | t_{DS} | -- | 80 | -- | ns |
| Data Hold Time | t_{DH} | -- | 40 | -- | ns |
| Access Time | t_{ACC} | -- | -- | 150 | ns |
| Output Hold Time | t_{OH} | -- | 10 | 50 | ns |

Example Initialization Program

```
//-----  
sbit ID = P3^1;  
sbit CS = P3^1;  
sbit RW = P3^0;  
sbit CE = P3^4;  
//sbit READ = P0^0;  
sbit FS = P3^2;  
sbit RST = P3^6;  
  
//-----  
void Writecom(char i)  
{  
    P1 = i;  
    ID = 1;  
    CE = 0;  
    RW = 0;  
    //delay(1);  
    RW = 1;  
    CE = 1;  
    //delay(1);  
}  
  
void Writedata(char i)  
{  
    P1 = i;  
    ID = 0;  
    CE = 0;  
    RW = 0;  
    //delay(1);  
    RW = 1;  
    CE = 1;  
    //delay(1);  
}  
//-----  
void Init()  
{  
    RST = 1;  
    RD = 1;  
    FS = 0;  
  
    Writedata(0x00);  
    Writedata(0x00);  
    Writecom(0x40);  
    Writedata(0x00);  
    Writedata(0x40);  
    Writecom(0x42);  
    Writedata(0x1E);  
    Writedata(0x00);  
    Writecom(0x41);  
    Writedata(0x1E);  
    Writedata(0x00);  
    Writecom(0x43);  
    Writecom(0x80);  
}
```

Quality Information

| Test Item | Content of Test | Test Condition | Note |
|---------------------------------------|---|---|------|
| High Temperature storage | Endurance test applying the high storage temperature for a long time. | +80°C , 48hrs | 2 |
| Low Temperature storage | Endurance test applying the low storage temperature for a long time. | -30°C , 48hrs | 1,2 |
| High Temperature Operation | Endurance test applying the electric stress (voltage & current) and the high thermal stress for a long time. | +70°C , 48hrs | 2 |
| Low Temperature Operation | Endurance test applying the electric stress (voltage & current) and the low thermal stress for a long time. | -20°C , 48hrs | 1,2 |
| High Temperature / Humidity Operation | Endurance test applying the electric stress (voltage & current) and the high thermal with high humidity stress for a long time. | +40°C , 90% RH , 48hrs | 1,2 |
| Thermal Shock resistance | Endurance test applying the electric stress (voltage & current) during a cycle of low and high thermal stress. | 0°C,30min -> 25°C,5min -> 50°C,30min = 1 cycle 10 cycles | |
| Vibration test | Endurance test applying vibration to simulate transportation and use. | 10-55Hz , 15mm amplitude. 60 sec in each of 3 directions X,Y,Z For 15 minutes | 3 |
| Static electricity test | Endurance test applying electric static discharge. | VS=800V, RS=1.5kΩ, CS=100pF One time | |

Note 1: No condensation to be observed.

Note 2: Conducted after 4 hours of storage at 25°C, 0%RH.

Note 3: Test performed on product itself, not inside a container.

Precautions for using LCDs/LCMs

See Precautions at www.newhavendisplay.com/specs/precautions.pdf

Warranty Information and Terms & Conditions

http://www.newhavendisplay.com/index.php?main_page=terms



Компания «ЭлектроПласт» предлагает заключение долгосрочных отношений при поставках импортных электронных компонентов на взаимовыгодных условиях!

Наши преимущества:

- Оперативные поставки широкого спектра электронных компонентов отечественного и импортного производства напрямую от производителей и с крупнейших мировых складов;
- Поставка более 17-ти миллионов наименований электронных компонентов;
- Поставка сложных, дефицитных, либо снятых с производства позиций;
- Оперативные сроки поставки под заказ (от 5 рабочих дней);
- Экспресс доставка в любую точку России;
- Техническая поддержка проекта, помощь в подборе аналогов, поставка прототипов;
- Система менеджмента качества сертифицирована по Международному стандарту ISO 9001;
- Лицензия ФСБ на осуществление работ с использованием сведений, составляющих государственную тайну;
- Поставка специализированных компонентов (Xilinx, Altera, Analog Devices, Intersil, Interpoint, Microsemi, Aeroflex, Peregrine, Syfer, Eurofarad, Texas Instrument, Miteq, Cobham, E2V, MA-COM, Hittite, Mini-Circuits, General Dynamics и др.);

Помимо этого, одним из направлений компании «ЭлектроПласт» является направление «Источники питания». Мы предлагаем Вам помощь Конструкторского отдела:

- Подбор оптимального решения, техническое обоснование при выборе компонента;
- Подбор аналогов;
- Консультации по применению компонента;
- Поставка образцов и прототипов;
- Техническая поддержка проекта;
- Защита от снятия компонента с производства.



Как с нами связаться

Телефон: 8 (812) 309 58 32 (многоканальный)

Факс: 8 (812) 320-02-42

Электронная почта: org@eplast1.ru

Адрес: 198099, г. Санкт-Петербург, ул. Калинина, дом 2, корпус 4, литера А.