

Power Amplifier with Adjustable Current Limiting

DESCRIPTION

Demonstration circuit 453B is useful for evaluating the LT1970A, a power amplifier with adjustable current limiting. The demo circuit is available in two versions; DC453B-A with up to 500mA of output current and DC453B-B for applications with up to 5 Amps of output current. For the 5 Amp version a Class B MOSFET based current boost stage has been added to the output section with current limit control still provided by the LT1970A.

The maximum output current of the board is set by two on-board potentiometers to permit independent control of the sinking and sourcing current limit. The current limit adjustment can also be provided by external voltage sources. Symmetrical sourcing and sinking current limit with a single control is also possible.

LEDs provide an indication of faults detected by the LT1970A. Separate indicators illuminate when the amplifier enters sourcing or sinking current limit and if the LT1970A overheats and enters thermal shutdown protection.

Several jumpers enable flexible amplifier operation. Configurations include:

- Single or dual power supplies
- Separate or common input stage and power output stage supplies
- AC or DC coupled inputs
- Non-Inverting gains of 1 or 2, Inverting gain of -1
- Separate or common current limit control

Design files for this circuit board are available. Call the LTC factory.

LT, LTC and LT are registered trademarks of Linear Technology Corporation. ThinSOT and PowerPath are trademarks of Linear Technology Corporation.

TYPICAL PERFORMANCE SUMMARY

T_A = 25°C, Common ±12V Supplies

SYMBOL	PARAMETER	CONDITIONS	MIN	TYP	MAX	UNITS	
V _{SUPPLY}	Power Supply Range	Single Supply	8		36	V	
		Dual Supply	±8		±18	V	
I _{OUT}	Adjustable Output Current Limit Range	DC453B-A (LT1970A basic amplifier), V _{CC} ≥ 8V DC453B-B (Boosted)	±4 ±0.04		±500 ±5	mA A	
BW _S	Small Signal -3dB Bandwidth	DC453B-A (LT1970A basic amplifier) A _V = +1, V _{out} = 200mV _{P-P} , R _{LOAD} = 100Ω, DC453B-B (Boosted) A _V = +1, V _{out} = 200mV _{P-P} , R _{LOAD} = 10Ω		1.6		MHz	
				7.2		KHz	
BW _L	Large Signal -3dB Bandwidth	DC453B-A (LT1970A basic amplifier) A _V = +1, V _{out} = 20V _{P-P} , R _{LOAD} = 100Ω DC453B-B (Boosted) A _V = +1, V _{out} = 10V _{P-P} , R _{LOAD} = 10Ω,		58		KHz	
				7		KHz	
SR	Slew Rate			1.6		V/μS	
V _{SATH}	Output Sat Voltage High	DC453B-A (LT1970A basic amplifier), V _{SAT} = V ₊ - V _{OUT} Common ±12V Supplies, R _{LOAD} = 250Ω		1.4 2.1		V V	
		Common ±12V Supplies, R _{LOAD} = 25Ω		0.1		V	
		V _{CC} /V _{EE} = ±12V and V ₊ /V ₋ = ±5V, R _{LOAD} = 100Ω		0.8		V	
		V _{CC} /V _{EE} = ±12V and V ₊ /V ₋ = ±5V, R _{LOAD} = 10Ω					

TYPICAL PERFORMANCE SUMMARY

$T_A = 25^\circ\text{C}$, Common $\pm 12\text{V}$ Supplies

SYMBOL	PARAMETER	CONDITIONS	MIN	TYP	MAX	UNITS
		DC453B-B (Boosted), See Operational Notes				
V_{SATL}	Output Sat Voltage Low	DC453B-A (LT1970A basic amplifier), $V_{SAT} = V_{OUT} - V_-$ Common $\pm 12\text{V}$ Supplies, $R_{LOAD} = 250\Omega$ Common $\pm 12\text{V}$ Supplies, $R_{LOAD} = 25\Omega$ $V_{CC}/V_{EE} = \pm 12\text{V}$ and $V_+/V_- = \pm 5\text{V}$, $R_{LOAD} = 100\Omega$ $V_{CC}/V_{EE} = \pm 12\text{V}$ and $V_+/V_- = \pm 5\text{V}$, $R_{LOAD} = 10\Omega$		2.1 2.8 0.3 1.3		V V V V
		DC453B-B (Boosted), See Operational Notes				
I_S	Total Quiescent Supply Current	No Load DC453B-A (LT1970A basic amplifier) DC453B-B (Boosted)		9 12		mA mA

QUICK START PROCEDURE

Demonstration circuit 453B is easy to set up to evaluate the performance of the LT1970A. Before applying power to the amplifier, configure all on-board jumpers for the desired operation. Figure 1 provides an overview of how

JP1: Input Signal Coupling, AC or DC

the placement of each of the jumpers adjusts the configuration. Position each jumper for the following results:

DC coupling, non-inverting, applies the input signal directly to the amplifier + input with a $5\text{K}\Omega$ input impedance, inverting, directly connects to a $10\text{K}\Omega$ resistor to the amplifier – input.

AC coupling connects the input signal through a series $10\mu\text{F}$ capacitor. Depending on the amplifier topology the lower –3dB corner frequency is in the range of 1.6Hz to 6.2Hz.

JP2: Inverting (INV) or Non-Inverting (NI)

Directs the input signal for an Inverting or Non-Inverting amplifier.

JP3: Input biasing for SINGLE or DUAL Power Supplies

DUAL sets the DC bias of the inputs and output to ground when symmetrical dual + and - power supplies are used.

SINGLE sets the DC bias of the inputs and output to $\frac{1}{2} V_{CC}$ when a single power supply is used. This setting also biases the inputs and output to the midpoint of asymmetrical dual supplies.

Removing the shunt from this jumper can allow the power amplifier to bias at the same dc potential as the input signal for DC coupled single supply uses.

JP4: Gain Configuration Setting

The four positions of this jumper configure the amplifier to one of three gain values. The inset diagram on the schematic, Figure 4, shows how the amplifier feedback is arranged for each jumper position. A small table is also included on the printed circuit board to serve as a ready reference for the jumper settings.

The jumper position shorting pins 2 and 3 provides the same configuration as shorting pins 3 and 4.

JP5: Separate (S) or Common (C) Current Limit Control

Separate (S) position allows for the independent setting of the amplifier sourcing current limit and sinking current

limit through two 10K potentiometers and an on-board 5V regulator. Any voltage between 0V and 5V applied to the LT1970A pins VCSRC and VCSNK sets the output current limit value.

Common (C) position connects the VCSRC and VCSNK input pins together to force the sourcing and sinking current limit values to be the same. With this setting, only the potentiometer labeled VCSRC adjusts the current limit control voltage.

JP6: Vee biasing for SINGLE or DUAL Power Supplies

SINGLE setting connects the Vee supply of the LT1970A directly to ground.

DUAL setting connects the Vee supply to the VEE input jack.

With the Common (COM) selection just one power source, a single positive supply, or one pair of plus and minus supplies, is required. This supply powers both **JP7: Common (COM) or Separate (SEP) Power Supplies** the input stage supplies of the LT1970A, Vcc and Vee, and the output stage supplies, V+ and V-.

With the Separate (SEP) selection the output stage supplies must be provided separately to the V+ and V- input jacks. This feature reduces power dissipation in the output stage by running the supplies at a lower value than the main amplifier input stage.

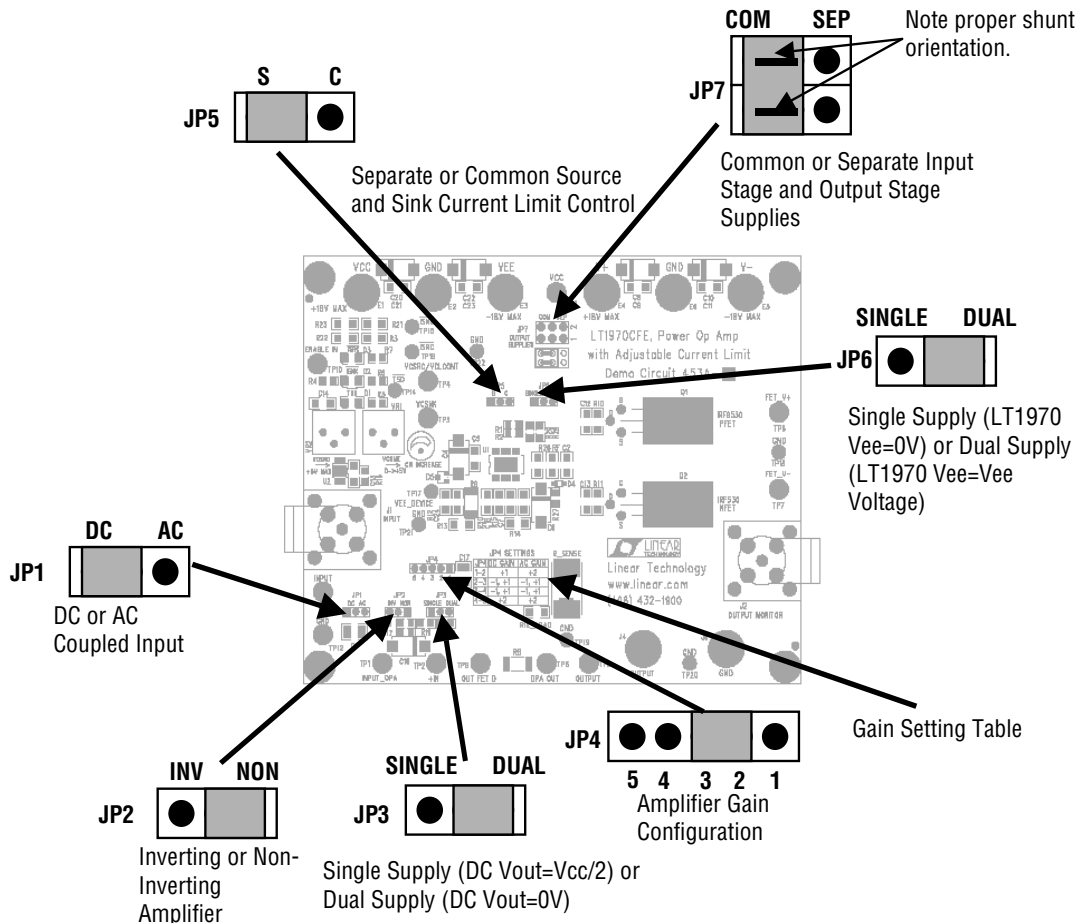

Figure 1. DC453B Jumper Configuration

POWER CONNECTIONS

Figure 2 shows how to properly connect power to the 453B demo circuit.

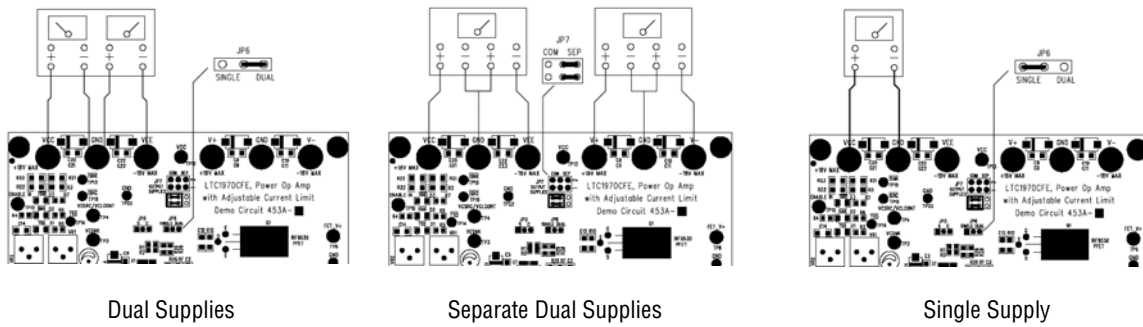

Figure 2. Power Supply Connections

OPTIONAL EXTERNAL CONNECTIONS

Several test point turrets have been added, see Figure 3, to make it easy to use external equipment to control the operation of the power amplifier.

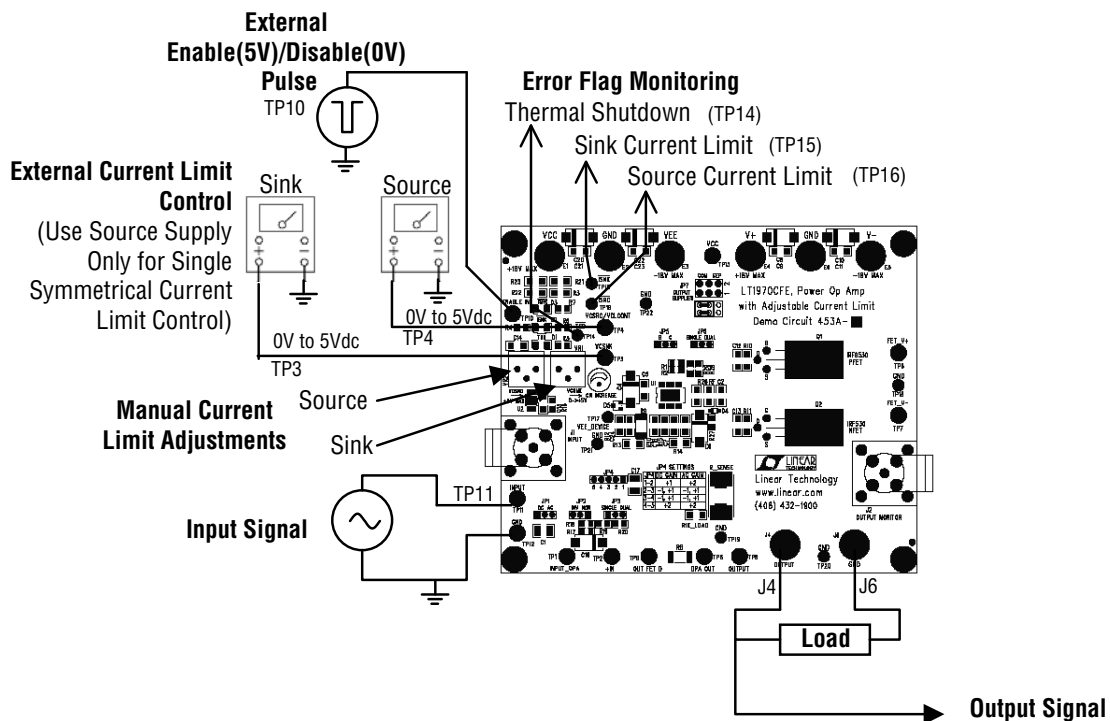

Figure 3. External Control Options

OPERATIONAL NOTES

Minimum Supply Voltage

The LT1970A can operate with a total supply voltage of only 5 Volts. For convenience, a 5V regulator is included on DC453B to provide the control voltage for the current limit adjustments. To keep this regulator properly biased the minimum positive Vcc supply must be at least 8 Volts when using either a single or dual power supply. Lower supply voltage is possible if external current limit control voltages are provided.

Current Limit Control

To ensure proper operation of the LT1970A two 100kΩ resistors to ground are connected to the two current limit control inputs with jumper JP5 removed. The effect of these resistors slightly attenuates the current limit control voltages provided by the on-board potentiometers. With separate limit control, the maximum voltage is 4.6V. When tied together for common control the maximum voltage is 4.2V.

The actual current limit of DC453B is actually slightly greater than the expected nominal value at higher output current levels (greater than 400mA for the –A version and 4A for the –B version). The reason for this is the inclusion of diode package D5. The back-to-back diodes across the current sense inputs prevent erratic behavior in the unlikely event of an abrupt output short circuit condition. These diodes limit the maximum voltage difference seen at the sense amplifier inputs. When the voltage across the sense resistor, Rsense, exceeds 0.4 Volts, the diodes begin to conduct current and decrease the actual voltage difference seen by the sense amplifier.

Boosted Current Version

DC453B-B contains complimentary P and N channel power MOSFETs for output current up to ±5A. The same easy voltage control of the output current is provided by

the LT1970A. The current boost stage is a class B design intended for DC and low frequency applications.

The crossover distortion of this typical Class B design is apparent at frequencies greater than 7kHz. Above this frequency, the total time in crossover becomes 10% or more of the period of a sine wave input.

The frequency response of the current boosted amplifier will vary as a function of the load resistance. Resistor R9, 100Ω, and the load resistor create an attenuation network inside the feedback loop of the amplifier. This causes the LT1970A to run at a higher closed loop gain than the overall amplifier gain, limiting the observed output

$$F_{-3dB} = \frac{1}{2\pi R_F C_{24} \cdot \left(1 + \frac{R_9}{R_{load}}\right)}$$

closed loop frequency response. The –3dB corner frequency of the boosted amplifier is:

Where R_F (10KΩ) and C₂₄ (220pf) are feedback components already provided on the board. Refer to the Figure 4 schematic. With no load, the non-inverting unity gain bandwidth is 72kHz. Depending on signal levels the usable bandwidth may be less due to the 1.6V/μs slew rate.

The large power MOSFETs in the output stage can pull the output voltage very near the supply voltage rails. This can cause the sense amplifier inputs to exceed their input common mode voltage range, which is 1V away from either the Vcc or Vee supply rail. This can cause what appears to be a latch-up condition where the output goes to one rail or the other and illuminates the current limit indicators. Reducing the input voltage and cycling the power supplies will reset the amplifier back to normal. To prevent this from occurring, places for resistor divider networks to reduce the voltages seen at the sense amplifier inputs are provided. These are resistors R12 through R15 on the board. The identical divider networks should ensure that the peak voltages at the sense amplifier inputs are never within 1 Volt of the Vcc or Vee supply rails.

ECO	REV	DESCRIPTION	APPROVED	DATE
—	1	PRODUCTION	TIM R.	11-28-12

REVISION HISTORY

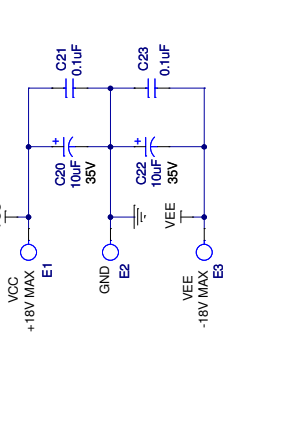
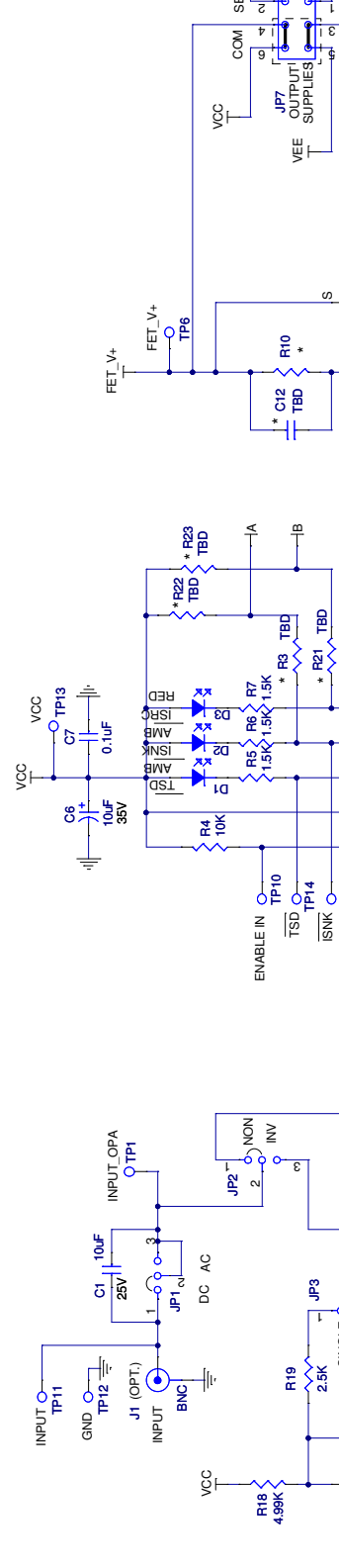

JP4 SETTINGS

JP4	DC GAIN	AC GAIN
1-2	+1	+2
2-3	-1, +1	-1, +1
3-4	-1, +1	-1, +1
4-5	+2	+2

JP4 SETTING DIAGRAM

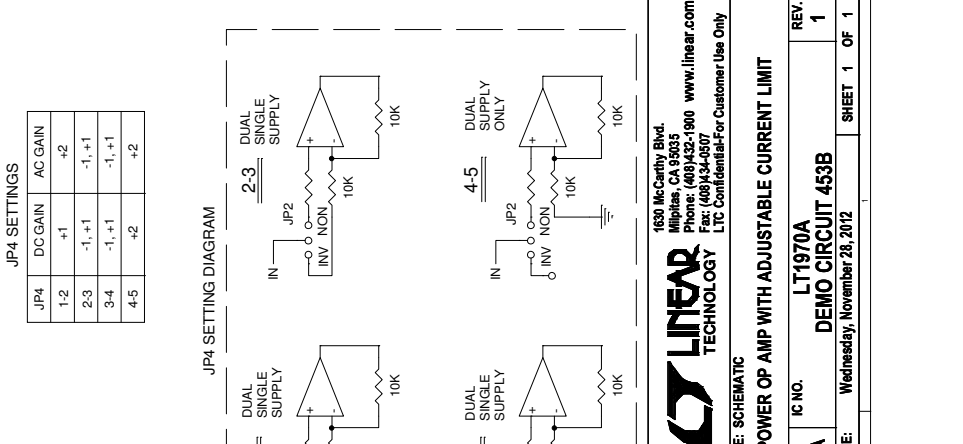
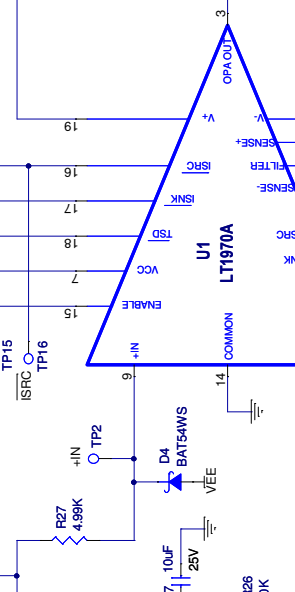

CUSTOMER NOTICE

LINEAR TECHNOLOGY HAS MADE AN BEST EFFORT TO DESIGN A CIRCUIT THAT MEETS CUSTOMER-SUPPLIED SPECIFICATIONS. HOWEVER, IT REMAINS THE CUSTOMER'S RESPONSIBILITY TO VERIFY PROPER AND RELIABLE OPERATION IN THE ACTUAL APPLICATION. COMPONENT SUBSTITUTION AND PRINTED CIRCUIT BOARD MANUFACTURING VARIATIONS CAN AFFECT CIRCUIT PERFORMANCE OR RELIABILITY. CONTACT LINEAR TECHNOLOGY APPLICATIONS ENGINEERING FOR ASSISTANCE.

THIS CIRCUIT IS PROPRIETARY TO LINEAR TECHNOLOGY AND SUPPLIED FOR USE WITH LINEAR TECHNOLOGY PARTS.

APPROVALS

PCB DES.	AK
APP ENG.	TIM R.

POWER OP AMP WITH ADJUSTABLE CURRENT LIMIT

LT1970A
 DEMO CIRCUIT 453B
 DATE: Wednesday, November 28, 2012
 SHEET 1 OF 1

*** VERSION TABLE**

Assembly Type	R9, R10, R11	R8	R12/R14	Q1, Q2	R_SENSE	C12, C13	R13, R15	R3, R21, R22, R23
DC453B-A	0 JUMPER	NOT INSTALLED	NOT INSTALLED	NOT INSTALLED	10HM	NOT INSTALLED	0 JUMPER	NOT INSTALLED
NON-BOOSTED	100	NOT INSTALLED	NOT INSTALLED	NOT INSTALLED	>=0.5W	INSTALLED	0 JUMPER	NOT INSTALLED
DC453B-B	100	INSTALLED	NOT INSTALLED	NOT INSTALLED	0.1 OHM	INSTALLED	0 JUMPER	NOT INSTALLED
BOOSTED	100	INSTALLED	INSTALLED	INSTALLED	>=3W	INSTALLED	0 JUMPER	INSTALLED



1630 McCarty Blvd.
 Milpitas, CA 95035
 Phone: (408)432-1900 www.linear.com
 Fax: (408)434-0507
 LTC Confidential-For Customer Use Only

LINEAR TECHNOLOGY

TITLE: SCHEMATIC
 POWER OP AMP WITH ADJUSTABLE CURRENT LIMIT
 LT1970A
 DEMO CIRCUIT 453B
 DATE: Wednesday, November 28, 2012
 SHEET 1 OF 1



Компания «ЭлектроПласт» предлагает заключение долгосрочных отношений при поставках импортных электронных компонентов на взаимовыгодных условиях!

Наши преимущества:

- Оперативные поставки широкого спектра электронных компонентов отечественного и импортного производства напрямую от производителей и с крупнейших мировых складов;
- Поставка более 17-ти миллионов наименований электронных компонентов;
- Поставка сложных, дефицитных, либо снятых с производства позиций;
- Оперативные сроки поставки под заказ (от 5 рабочих дней);
- Экспресс доставка в любую точку России;
- Техническая поддержка проекта, помощь в подборе аналогов, поставка прототипов;
- Система менеджмента качества сертифицирована по Международному стандарту ISO 9001;
- Лицензия ФСБ на осуществление работ с использованием сведений, составляющих государственную тайну;
- Поставка специализированных компонентов (Xilinx, Altera, Analog Devices, Intersil, Interpoint, Microsemi, Aeroflex, Peregrine, Syfer, Eurofarad, Texas Instrument, Miteq, Cobham, E2V, MA-COM, Hittite, Mini-Circuits, General Dynamics и др.);

Помимо этого, одним из направлений компании «ЭлектроПласт» является направление «Источники питания». Мы предлагаем Вам помощь Конструкторского отдела:

- Подбор оптимального решения, техническое обоснование при выборе компонента;
- Подбор аналогов;
- Консультации по применению компонента;
- Поставка образцов и прототипов;
- Техническая поддержка проекта;
- Защита от снятия компонента с производства.



Как с нами связаться

Телефон: 8 (812) 309 58 32 (многоканальный)

Факс: 8 (812) 320-02-42

Электронная почта: org@eplast1.ru

Адрес: 198099, г. Санкт-Петербург, ул. Калинина, дом 2, корпус 4, литера А.