

DBL5W5S700G30LF

REFERENCE SPECIFICATIONS

-NFC 93425 (in compliance with HE 507)

PHYSICAL CHARACTERISTICS

- INSULATOR MATERIAL: THERMOPLASTIC ,UL94V0
- CONTACT MATERIAL: BRASS
- ACCESSORIES: BRASS
- SHELLS: STEEL

ELECTRICAL CHARACTERISTICS

- NOMINAL CURRENT: 30A
- CONTACT RESISTANCE: <= 7.3 m ohms
- CONTACT/CONTACT : >=1000 V
- CONTACT/GROUND : >=1200 V
- INSULATION RESISTANCE: >=5000 MOhms

ENVIRONMENTAL CHARACTERISTICS

- CLIMATIC CATEGORY: 55/125/21
- TEMPERATURE RANGE -55°C TO +125°C
- DAMP HEAT STEADY STATE 21 DAYS
- SALT SPRAY 24 HOURS

MECHANICAL CHARACTERISTICS

- RETENTION AGAINST TORQUE: - Threaded insert: 0.7 N.m minimum
- Female screw : 0.5 N.m minimum

Series

Shell size: **E A B C**
see sheet 3

Front accessory definition
see sheet 2

- blank** :without accessory
- L** :threaded insert M3
- O** :threaded insert UNC 4-40
- V** :female screw UNC 4-40

Layout of contacts (see sheets)

Contacts

S :Socket

Termination type
7 Right angle/USA

Plating
00 200 matings/unmatings
43 500 matings/unmatings

PCB accessories definition
see sheet 2

- A** :without accessory
- H** :Metal brackets+harpoons for PCB 2.40mm
- G** :Metal brackets+harpoons for PCB 1.60mm
- M** :Metal brackets

Power contacts
00 :Not fitted with power contact (signal contacts always fitted)
30 :Fitted with power contacts 30 Amp.

See note RoHS

TABLE 1:PCB HOLE DIAMETERS

	POWER CONTACTS		ACCESSORIES
30 A	∅2.00	∅2.40	∅3.10
Max current power	∅A +0.1 0	PCB HOLE +/-0.1	PCB HOLE +/-0.1

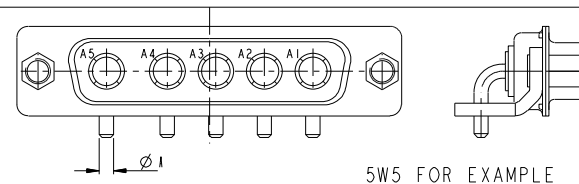

NOTE RoHS INFORMATION

- The "LF" products meet european union Directives and other country regulations as described in GS-22-008.
- The housing will withstand exposure to 260°C peak temperature for 3.5 seconds in a wave solder application with a 1.6mm minimum thick circuit board. See application notes/procedures if they are available.
- Termination plating spec:
 - Ni 1.27µm+Sn 2.5 to 7.5µm(pure bright)
- Active area plating spec:
 - Ni + Gold
 - Shell plating :2 to 4µm Cu + Ni + 3 to 10µm Sn(pure bright)
 - Accessories: Sn pure bright + Nickel
- Packaging spec: See GS-14-920

www.fciconnect.com		surface	tolerance std	projection	mm
		ISO 1302	ISO 406 ISO 1101		
		TOLERANCES UNLESS OTHERWISE SPECIFIED			
Dr	M PESSON	2005-10-11	ANGULAR	0.X ±0.3	size A2
Eng	P LEGARE	2005-10-11	LINEAR	0.XX ±0.1	Scale 2:1
Chr			0° ±2°	0.XXX ±0.05	ECN F09-0092
Appr			Product family	Spec ref	

rev	ecn no	dr	date	title	sub	part no	Rev.
A	LS05-0113	MPE	2005-10-11	SUB FEMALE DW US foot print		C01-8639-2309	E
B	LS06-0208	LGO	2006-12-13	full power right angled solder			
C	LS07-0085	MPE	2007/03/21				
D	LS07-0213	MPE	2007/11/05				
E	F09-0092	LSA	2009/09/16				



FRONT ACCESSORY	Blank Without	L insert M3 O insert UNC 4.40	V insert UNC 4.40	Blank Without	L insert M3 O insert UNC 4.40	V insert UNC 4.40
PCB ACCESSORIES	A Without	A Without	A Without	M Metal brackets	M Metal brackets	M Metal bracket

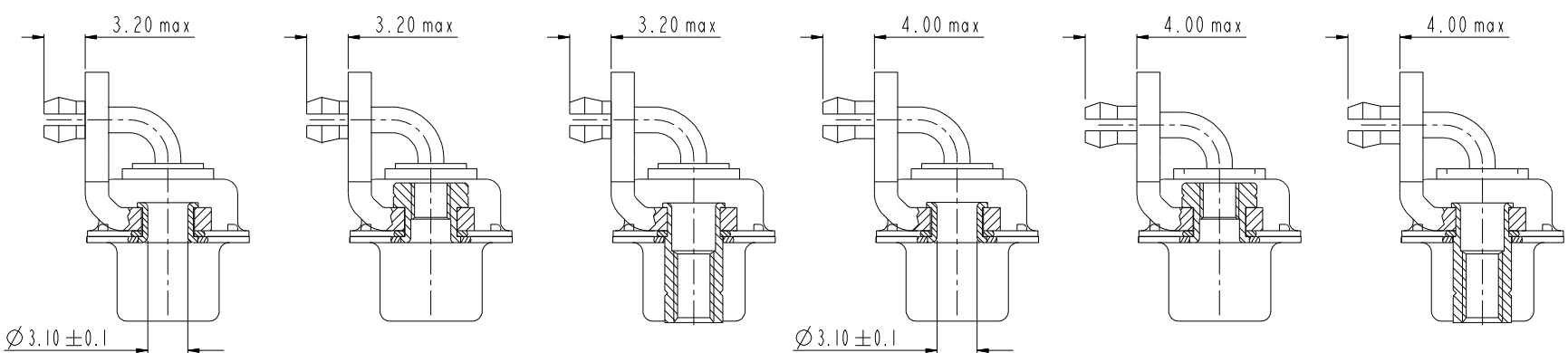

FRONT ACCESSORY	Blank Without	L insert M3 O insert UNC 4.40	V insert UNC 4.40	Blank Without	L insert M3 O insert UNC 4.40	V insert UNC 4.40
PCB ACCESSORIES	G Metal brackets + harpoons for PCB 1.60mm	G Metal brackets + harpoons for PCB 1.60mm	G Metal brackets + harpoons for PCB 1.60mm	H Metal brackets + harpoons for PCB 2.40mm	H Metal brackets + harpoons for PCB 2.40mm	H Metal brackets + harpoons for PCB 2.40mm

www.fciconnect.com		surface ISO 1302	tolerance std ISO 406 ISO 1101	projection mm
TOLERANCES UNLESS OTHERWISE SPECIFIED				
Dr	M PESSON	2005-10-11	ANGULAR	size A2
Eng	P LEGARE	2005-10-11	LINEAR	Scale 2:1
Chr			0° ±2°	ECN F09-0092
Appr			Product family	Spec ref

FCI	title SUB FEMALE DW US foot print	part no C01-8639-2309	Rev. E
	full power right angled solder		

SCALE: 4

PART NUMBER	AMPS	MATINGS/ UNMATINGS	FRONT ACCESSORY	PCB ACCESSORIES
D*xWxS700A30LF	30	200	without	without
D*LxWxS700A30LF	30	200	insert M3	without
D*OxWxS700A30LF	30	200	insert UNC 4.40	without
D*VxWxS700A30LF	30	200	female screw UNC 4.40	without
D*xWxS700H30LF	30	200	without	metal bracket+harpoon PCB 2.40mm
D*LxWxS700H30LF	30	200	insert M3	metal bracket+harpoon PCB 2.40mm
D*OxWxS700H30LF	30	200	insert UNC 4.40	metal bracket+harpoon PCB 2.40mm
D*VxWxS700H30LF	30	200	female screw UNC 4.40	metal bracket+harpoon PCB 2.40mm
D*xWxS700G30LF	30	200	without	metal bracket+harpoon PCB 1.60mm
D*LxWxS700G30LF	30	200	insert M3	metal bracket+harpoon PCB 1.60mm
D*OxWxS700G30LF	30	200	insert UNC 4.40	metal bracket+harpoon PCB 1.60mm
D*VxWxS700G30LF	30	200	female screw UNC 4.40	metal bracket+harpoon PCB 1.60mm
D*xWxS700M30LF	30	200	without	metal bracket
D*LxWxS700M30LF	30	200	insert M3	metal bracket
D*OxWxS700M30LF	30	200	insert UNC 4.40	metal bracket
D*VxWxS700M30LF	30	200	female screw UNC 4.40	metal bracket

shell size
#

E
A
A
B
C

LAYOUTS
xWx

2V2
3V3
3W3
5W5
8W8

PART NUMBER	AMPS	MATINGS/ UNMATINGS	FRONT ACCESSORY	PCB ACCESSORIES
D*xWxS743A30LF	30	500	without	without
D*LxWxS743A30LF	30	500	insert M3	without
D*OxWxS743A30LF	30	500	insert UNC 4.40	without
D*VxWxS743A30LF	30	500	female screw UNC 4.40	without
D*xWxS743H30LF	30	500	without	metal bracket+harpoon PCB 2.40mm
D*LxWxS743H30LF	30	500	insert M3	metal bracket+harpoon PCB 2.40mm
D*OxWxS743H30LF	30	500	insert UNC 4.40	metal bracket+harpoon PCB 2.40mm
D*VxWxS743H30LF	30	500	female screw UNC 4.40	metal bracket+harpoon PCB 2.40mm
D*xWxS743G30LF	30	500	without	metal bracket+harpoon PCB 1.60mm
D*LxWxS743G30LF	30	500	insert M3	metal bracket+harpoon PCB 1.60mm
D*OxWxS743G30LF	30	500	insert UNC 4.40	metal bracket+harpoon PCB 1.60mm
D*VxWxS743G30LF	30	500	female screw UNC 4.40	metal bracket+harpoon PCB 1.60mm
D*xWxS743M30LF	30	500	without	metal bracket
D*LxWxS743M30LF	30	500	insert M3	metal bracket
D*OxWxS743M30LF	30	500	insert UNC 4.40	metal bracket
D*VxWxS743M30LF	30	500	female screw UNC 4.40	metal bracket

www.fciconnect.com		surface ISO 1302	tolerance std ISO 406 ISO 1101	projection 	mm
TOLERANCES UNLESS OTHERWISE SPECIFIED					
Dr	M PESSON	2005-10-11	ANGULAR	0.X ±0.3	size A2
Eng	P LEGARE	2005-10-11	LINEAR	0.XX ±0.1	Scale 2:1
Chr			0° ±2°	0.XXX ±0.05	ECN F09-0092
Appr			Product family		Spec ref

	TITLE SUB FEMALE DW US foot print full power right angled solder	Eng no C01-8639-2309	Rev. E
---	--	-------------------------	-----------

2V2

LAYOUT AND CONNECTOR DIMENSIONS
For PCB hole diameters see table 1 sheet 1

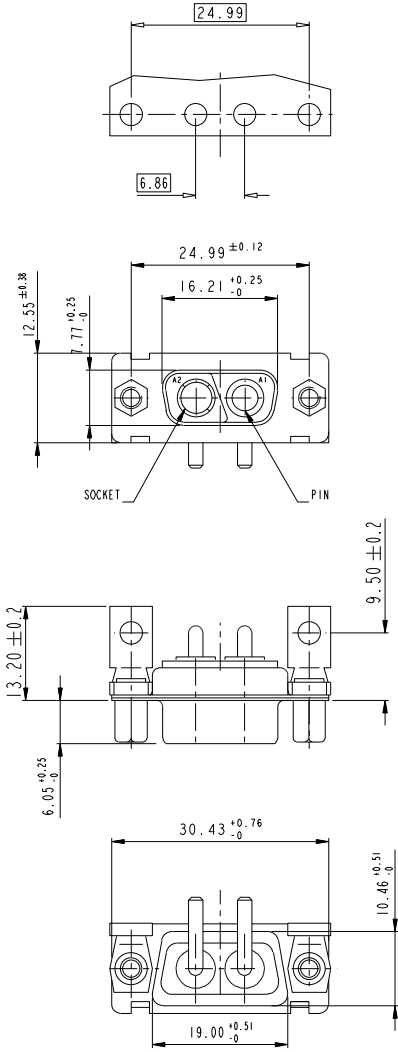

3V3

LAYOUT AND CONNECTOR DIMENSIONS
For PCB hole diameters see table 1 sheet 1

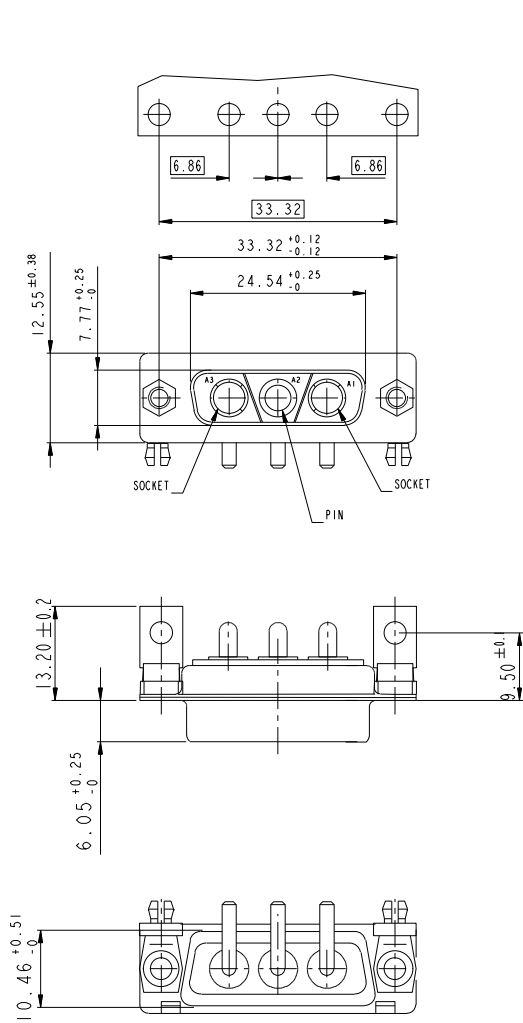

3W3

LAYOUT AND CONNECTOR DIMENSIONS
For PCB hole diameters see table 1 sheet 1

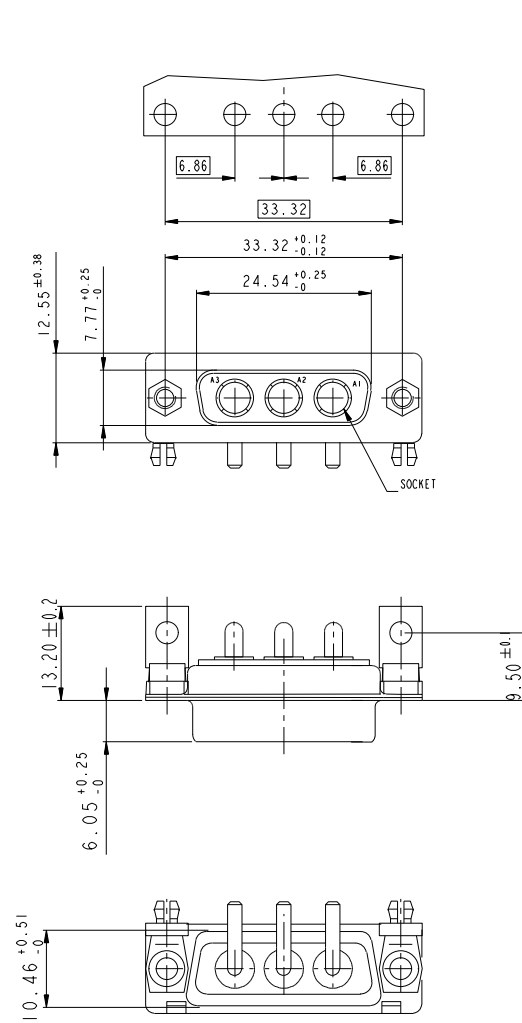

SIDE VIEW FOR ALL LAYOUTS

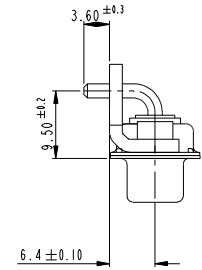

www.fciconnect.com		surface ISO 1302	tolerance std ISO 406 ISO 1101	projection mm
TOLERANCES UNLESS OTHERWISE SPECIFIED				
Dr	M PESSON	2005-10-11	ANGULAR	size A2
Eng	P LEGARE	2005-10-11	LINEAR	Scale 2:1
Chr			0° ± 2°	ECN F09-0092
Appr			Product family	Spec ref

FCI	TITLE SUB FEMALE DW US foot print	part no C01-8639-2309	Rev. E
	full power right angled solder		

5W5

LAYOUT AND CONNECTOR DIMENSIONS
For PCB hole diameters see table 1 sheet 1

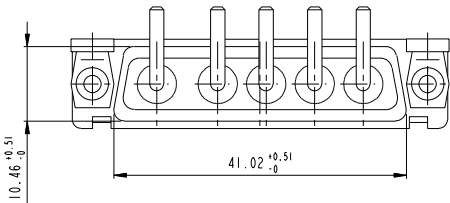
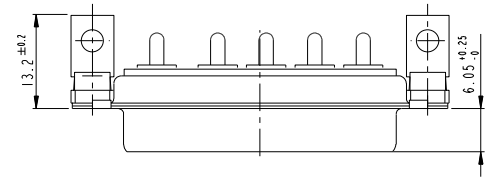
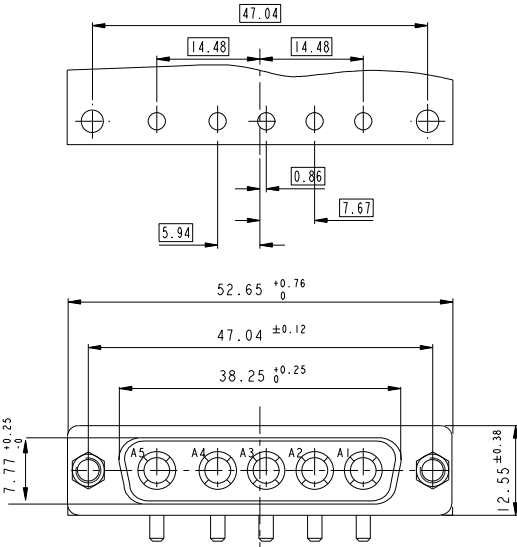

8W8

LAYOUT AND CONNECTOR DIMENSIONS
For PCB hole diameters see table 1 sheet 1

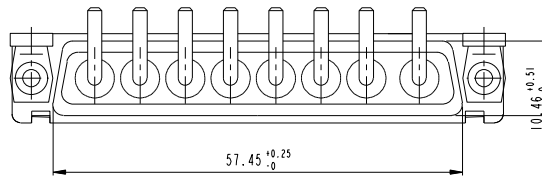
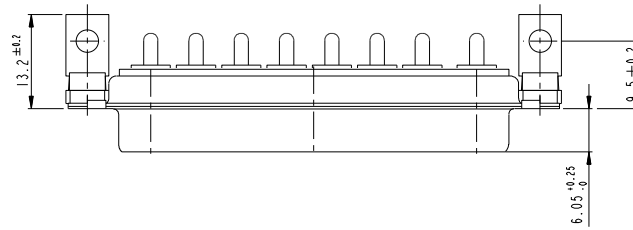
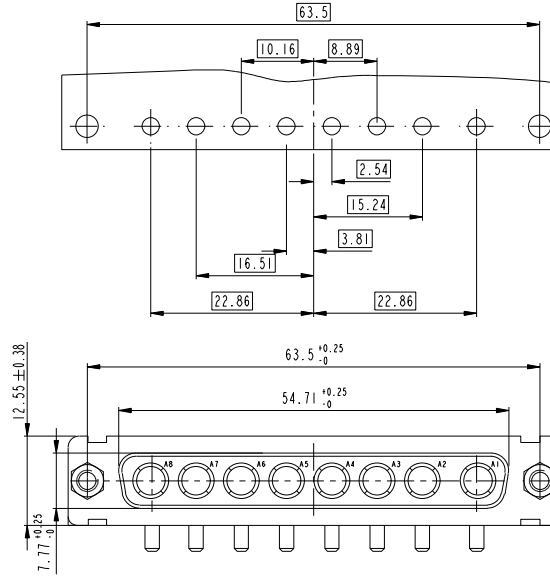

Copyright FCI. FCI

www.fciconnect.com		surface ISO 1302	tolerance std ISO 406 ISO 1101	projection mm
TOLERANCES UNLESS OTHERWISE SPECIFIED				
Dr	M PESSON	2005-10-11	ANGULAR	0.X ±0.3
Eng	P LEGARE	2005-10-11	LINEAR	0.XXX ±0.1
Chr			0° ±2°	0.XXX ±0.05
Appr			Product family	Spec ref

FCI	TITLE	SUB FEMALE DW US foot print	part no	C01-8639-2309	Rev.	E
		full power right angled solder				



Компания «ЭлектроПласт» предлагает заключение долгосрочных отношений при поставках импортных электронных компонентов на взаимовыгодных условиях!

Наши преимущества:

- Оперативные поставки широкого спектра электронных компонентов отечественного и импортного производства напрямую от производителей и с крупнейших мировых складов;
- Поставка более 17-ти миллионов наименований электронных компонентов;
- Поставка сложных, дефицитных, либо снятых с производства позиций;
- Оперативные сроки поставки под заказ (от 5 рабочих дней);
- Экспресс доставка в любую точку России;
- Техническая поддержка проекта, помощь в подборе аналогов, поставка прототипов;
- Система менеджмента качества сертифицирована по Международному стандарту ISO 9001;
- Лицензия ФСБ на осуществление работ с использованием сведений, составляющих государственную тайну;
- Поставка специализированных компонентов (Xilinx, Altera, Analog Devices, Intersil, Interpoint, Microsemi, Aeroflex, Peregrine, Syfer, Eurofarad, Texas Instrument, Miteq, Cobham, E2V, MA-COM, Hittite, Mini-Circuits, General Dynamics и др.);

Помимо этого, одним из направлений компании «ЭлектроПласт» является направление «Источники питания». Мы предлагаем Вам помощь Конструкторского отдела:

- Подбор оптимального решения, техническое обоснование при выборе компонента;
- Подбор аналогов;
- Консультации по применению компонента;
- Поставка образцов и прототипов;
- Техническая поддержка проекта;
- Защита от снятия компонента с производства.



Как с нами связаться

Телефон: 8 (812) 309 58 32 (многоканальный)

Факс: 8 (812) 320-02-42

Электронная почта: org@eplast1.ru

Адрес: 198099, г. Санкт-Петербург, ул. Калинина, дом 2, корпус 4, литера А.