

The MPC93R52 is a 3.3V compatible, 1:11 PLL based clock generator targeted for high performance clock tree applications. With output frequencies up to 240MHz and output skews lower than 200ps, the device meets the needs of most demanding clock applications.

Features

- Configurable 11 Outputs LVCMOS PLL Clock Generator
- Fully Integrated PLL
- Wide Range of Output Clock Frequency of 16.67MHz to 240MHz
- Multiplication of the Input Reference Clock Frequency by 3, 2, 1, 3 ÷ 2, 2 ÷ 3, 1 ÷ 3, and 1 ÷ 2
- 3.3 V LVCMOS Compatible
- Maximum Output Skew of 200ps
- Supports Zero-Delay Applications
- Designed for High-Performance Telecom, Networking and Computing Applications
- 32-Lead LQFP Package
- 32-Lead Pb-free Package Available
- Ambient Temperature Range – 0°C to +70°C
- Pin and Function Compatible to the MPC952

MPC93R52

**LOW VOLTAGE
3.3 V LVCMOS 1:11
CLOCK GENERATOR**



**FA SUFFIX
32-LEAD LQFP PACKAGE
CASE 873A-03**



**AC SUFFIX
32-LEAD LQFP PACKAGE
Pb-FREE PACKAGE
CASE 873A-03**

The MPC93R52 is a fully 3.3 V compatible PLL clock generator and clock driver. The device has the capability to generate output clock signals of 16.67MHz to 240MHz from external clock sources. The internal PLL is optimized for its frequency range and does not require external loop filter components. One output of the MPC93R52 has to be connected to the PLL feedback input FB_IN to close the external PLL feedback path. The output divider of this output setting determines the PLL frequency multiplication factor. This multiplication factor, F_RANGE and the reference clock frequency must be selected to situate the VCO in its specified lock range. The frequency of the clock outputs can be configured individually for all three output banks by the FSELx pins supporting systems with different but phase-aligned clock frequencies.

The PLL of the MPC93R52 minimizes the propagation delay and therefore supports zero-delay applications. All inputs and outputs are LVCMOS compatible. The outputs are optimized to drive parallel terminated 50 Ω transmission lines. Alternatively, each output can drive up to two series terminated transmission lines giving the device an effective fanout of 22.

The device also supports output high-impedance disable and a PLL bypass mode for static system test and diagnosis. The MPC93R52 is packaged in a 32-lead LQFP.

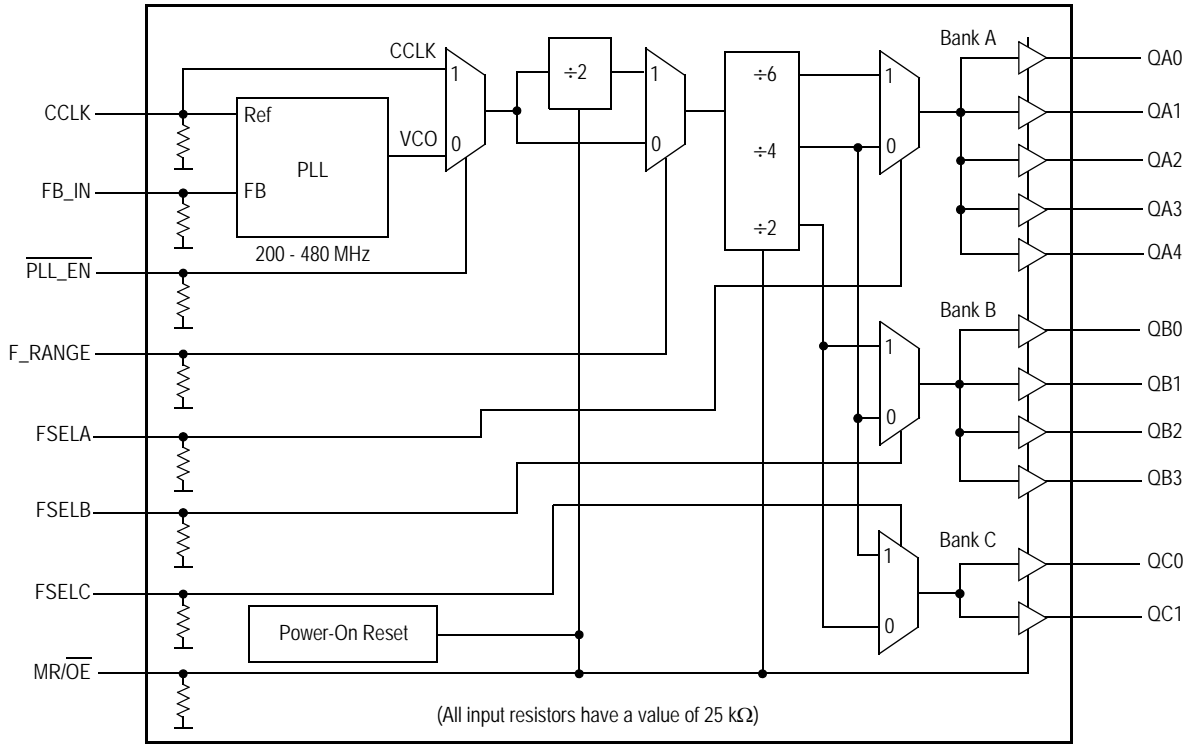
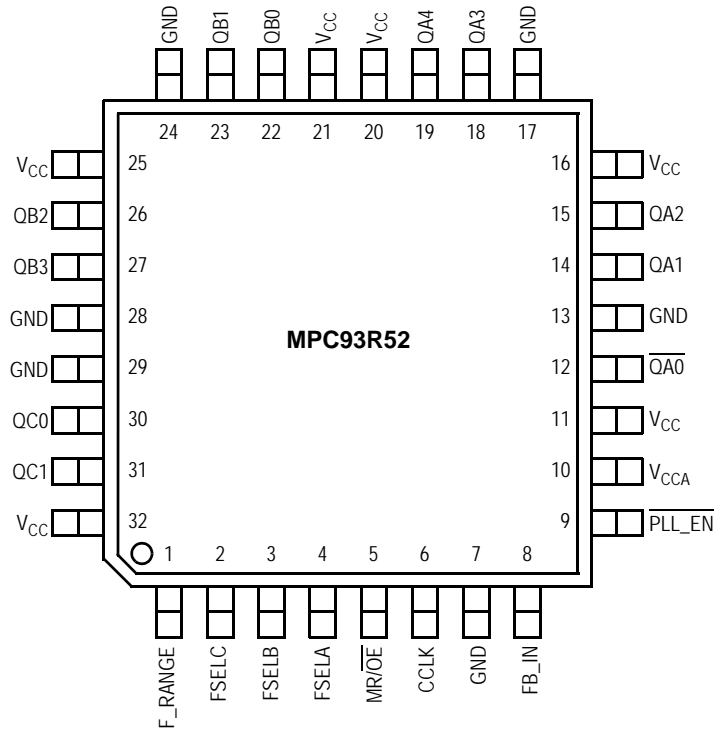

Figure 1. MPC93R52 Logic Diagram



It is recommended to use an external RC filter for the analog power supply pin VCCA. Please see [Applications Information](#) section for details.

Figure 2. Pinout: 32-Lead Package Pinout (Top View)

Table 1. Pin Configuration

Pin	I/O	Type	Function
CCLK	Input	LVC MOS	PLL reference clock signal
FB_IN	Input	LVC MOS	PLL feedback signal input, connect to an output
F_RANGE	Input	LVC MOS	PLL frequency range select
FSELA	Input	LVC MOS	Frequency divider select for bank A outputs
FSELB	Input	LVC MOS	Frequency divider select for bank B outputs
FSELC	Input	LVC MOS	Frequency divider select for bank C outputs
PLL_EN	Input	LVC MOS	PLL enable/disable
MR/ \overline{OE}	Input	LVC MOS	Output enable/disable (high-impedance tristate) and device reset
QA0–4, QB0–3, QC0–1	Output	LVC MOS	Clock outputs
GND	Supply	Ground	Negative power supply
V _{CCA}	Supply	V _{CC}	PLL positive power supply (analog power supply). It is recommended to use an external RC filter for the analog power supply pin V _{CCA} . Please see Applications Information section for details.
V _{CC}	Supply	V _{CC}	Positive power supply for I/O and core

Table 2. Function Table

Control	Default	0	1
<p>F_RANGE, FSELA, FSELB, and FSELC control the operating PLL frequency range and input/output frequency ratios. See Table 7 and Table 8 for supported frequency ranges and output to input frequency ratios.</p>			
F_RANGE	0	VCO ÷ 1 (High input frequency range)	VCO ÷ 2 (Low input frequency range)
FSELA	0	Output divider ÷ 4	Output divider ÷ 6
FSELB	0	Output divider ÷ 4	Output divider ÷ 2
FSELC	0	Output divider ÷ 2	Output divider ÷ 4
MR/ \overline{OE}	0	Outputs enabled (active)	Outputs disabled (high-impedance state) and reset of the device. During reset, the PLL feedback loop is open and the VCO is operating at its lowest frequency. The MPC93R52 requires reset after any loss of PLL lock. Loss of PLL lock may occur when the external feedback path is interrupted. The length of the reset pulse should be greater than two reference clock cycles (CCLK). The device is reset by the internal power-on reset (POR) circuitry during power-up.
PLL_EN	0	Normal operation mode with PLL enabled.	Test mode with PLL disabled. CCLK is substituted for the internal VCO output. MPC93R52 is fully static and no minimum frequency limit applies. All PLL related AC characteristics are not applicable.

Table 3. General Specifications

Symbol	Characteristics	Min	Typ	Max	Unit	Condition
V_{TT}	Output Termination Voltage		$V_{CC} \div 2$		V	
MM	ESD Protection (Machine Model)	200			V	
HBM	ESD Protection (Human Body Model)	2000			V	
LU	Latch-Up Immunity	200			mA	
C_{PD}	Power Dissipation Capacitance		10		pF	Per output
C_{IN}	Input Capacitance		4.0		pF	Inputs

Table 4. Absolute Maximum Ratings⁽¹⁾

Symbol	Characteristics	Min	Max	Unit
V_{CC}	Supply Voltage	-0.3	3.9	V
V_{IN}	DC Input Voltage	-0.3	$V_{CC} + 0.3$	V
V_{OUT}	DC Output Voltage	-0.3	$V_{CC} + 0.3$	V
I_{IN}	DC Input Current		± 20	mA
I_{OUT}	DC Output Current		± 50	mA
T_S	Storage Temperature	-65	125	°C

1. Absolute maximum continuous ratings are those maximum values beyond which damage to the device may occur. Exposure to these conditions or conditions beyond those indicated may adversely affect device reliability. Functional operation under absolute-maximum-rated conditions is not implied.

Table 5. DC Characteristics ($V_{CC} = 3.3 \text{ V} \pm 5\%$, $T_A = 0^\circ$ to 70°C)

Symbol	Characteristics	Min	Typ	Max	Unit	Condition
V_{IH}	Input high voltage	2.0		$V_{CC} + 0.3$	V	LVC MOS
V_{IL}	Input low voltage			0.8	V	LVC MOS
V_{OH}	Output High Voltage	2.4			V	$I_{OH} = -24 \text{ mA}^{(1)}$
V_{OL}	Output Low Voltage			0.55 0.30	V V	$I_{OL} = 24 \text{ mA}$ $I_{OL} = 12 \text{ mA}$
Z_{OUT}	Output impedance		14 – 17		Ω	
I_{IN}	Input Current ⁽²⁾			± 200	μA	$V_{IN} = V_{CC}$ or $V_{IN} = \text{GND}$
I_{CCA}	Maximum PLL Supply Current		3.0	5.0	mA	V_{CCA} Pin
$I_{CCQ}^{(3)}$	Maximum Quiescent Supply Current		7.0	1.0	mA	All V_{CC} Pins

1. The MPC93R52 is capable of driving 50Ω transmission lines on the incident edge. Each output drives one 50Ω parallel terminated transmission line to a termination voltage of V_{TT} . Alternatively, the device drives up to two 50Ω series terminated transmission lines.
2. Inputs have pull-down resistors affecting the input current.
3. I_{CCQ} is the DC current consumption of the device with all outputs open in high impedance state and the inputs in its default state or open.

Table 6. AC Characteristics ($V_{CC} = 3.3\text{ V} \pm 5\%$, $T_A = 0^\circ$ to 70°C)⁽¹⁾

Symbol	Characteristics	Min	Typ	Max	Unit	Condition
f_{ref}	Input reference frequency in PLL mode ⁽²⁾ ⁽³⁾	$\div 4$ feedback 50.0 $\div 6$ feedback 33.3 $\div 8$ feedback 25.0 $\div 12$ feedback 16.67		120.0 80.0 60.0 40.0	MHz MHz MHz MHz	
	Input reference frequency in PLL bypass mode ⁽⁴⁾	50.0		250.0	MHz	
f_{VCO}	VCO lock frequency range ⁽⁵⁾	200		480	MHz	
f_{MAX}	Output Frequency	$\div 2$ output ⁽⁶⁾	100	240	MHz	
		$\div 4$ output	50	120	MHz	
		$\div 6$ output	33.3	80	MHz	
		$\div 8$ output	25	60	MHz	
		$\div 12$ output	16.67	40	MHz	
t_{PWMIN}	Minimum Reference Input Pulse Width	2.0			ns	
t_r, t_f	CCLK Input Rise/Fall Time ⁽⁷⁾			1.0	ns	0.8 to 2.0 V
$t_{(\varnothing)}$	Propagation Delay CCLK to FB_IN (static phase offset)	$f_{ref} > 50\text{ MHz}$	-100	+200	ps	PLL locked
$t_{sk(O)}$	Output-to-output Skew ⁽⁸⁾	all outputs, any frequency within QA output bank within QB output bank within QC output bank		150	ps	
				100	ps	
				100	ps	
				50	ps	
DC	Output duty cycle	47	50	53	%	
t_r, t_f	Output Rise/Fall Time	0.1		1.0	ns	0.55 to 2.4 V
$t_{PLZ, HZ}$	Output Disable Time			8	ns	
$t_{PZL, LZ}$	Output Enable Time			10	ns	
$t_{JIT(CC)}$	Cycle-to-cycle jitter	output frequencies mixed all outputs same frequency		400	ps	
				100	ps	
$t_{JIT(PER)}$	Period Jitter	output frequencies mixed all outputs same frequency		450	ps	
				100	ps	
$t_{JIT(\varnothing)}$	I/O Phase Jitter ⁽⁹⁾	$\div 4$ feedback divider RMS (1σ) $\div 6$ feedback divider RMS (1σ) $\div 8$ feedback divider RMS (1σ) $\div 12$ feedback divider RMS (1σ)		40	ps	
				50	ps	
				60	ps	
				80	ps	
BW	PLL closed loop bandwidth ⁽¹⁰⁾	$\div 4$ feedback $\div 6$ feedback $\div 8$ feedback $\div 12$ feedback		2.0 – 8.0	MHz	
				1.0 – 4.0	MHz	
				0.8 – 2.5	MHz	
				0.6 – 1.5	MHz	
t_{LOCK}	Maximum PLL Lock Time			10	ms	

- AC characteristics apply for parallel output termination of $50\ \Omega$ to V_{TT} .
- PLL mode requires $PLL_EN=0$ to enable the PLL and zero-delay operation.
- The PLL may be unstable with a divide by 2 feedback ratio.
- In PLL bypass mode, the MPC93R52 divides the input reference clock.
- The input frequency f_{ref} on CCLK must match the VCO frequency range divided by the feedback divider ratio FB: $f_{ref} = f_{VCO} \div FB$.
- See [Table 7](#) and [Table 8](#) for output divider configurations.
- The MPC93R52 will operate with input rise and fall times up to 3.0 ns, but the AC characteristics, specifically $t_{(\varnothing)}$, can only be guaranteed if t_r/t_f are within the specified range.
- See [Applications Information](#) section for part-to-part skew calculation.
- See [Applications Information](#) section for jitter calculation for other confidence factors with 1σ .
- 3 dB point of PLL transfer characteristics.

APPLICATIONS INFORMATION

Programming the MPC93R52

The MPC93R52 supports output clock frequencies from 16.67 to 240 MHz. Different feedback and output divider configurations can be used to achieve the desired input to output frequency relationship. The feedback frequency and divider should be used to situate the VCO in the frequency lock range between 200 and 480 MHz for stable and optimal operation. The FSELA, FSELB, FSELC pins select the

desired output clock frequencies. Possible frequency ratios of the reference clock input to the outputs are 1:1, 1:2, 1:3, 3:2 as well as 2:3, 3:1, and 2:1. [Table 7](#) and [Table 8](#) illustrate the various output configurations and frequency ratios supported by the MPC93R52. See also [Figure 3](#) to [Figure 6](#) for further reference. A $\div 2$ output divider cannot be used for feedback.

Table 7. MPC93R52 Example Configuration (F_RANGE = 0)

PLL Feedback	fref ⁽¹⁾ [MHz]	FSELA	FSELB	FSELC	QA[0:4]:fref ratio	QB[0:3]:fref ratio	QC[0:1]:fref ratio
VCO $\div 4$ ⁽²⁾	50–120	0	0	0	fref (50-120 MHz)	fref (50-120 MHz)	fref * 2 (100-240 MHz)
		0	0	1	fref (50-120 MHz)	fref (50-120 MHz)	fref (50-120 MHz)
		1	0	0	fref * 2 \div 3 (33-80 MHz)	fref (50-120 MHz)	fref * 2 (100-240 MHz)
		1	0	1	fref * 2 \div 3 (33-80 MHz)	fref (50-120 MHz)	fref (50-120 MHz)
VCO $\div 6$ ⁽³⁾	33.3–80	1	0	0	fref (33-80 MHz)	fref * 3 \div 2 (50-120 MHz)	fref * 3 (100-240 MHz)
		1	0	1	fref (33-80 MHz)	fref * 3 \div 2 (50-120 MHz)	fref * 3 \div 2 (50-120 MHz)
		1	1	0	fref (33-80 MHz)	fref * 3 (100-240 MHz)	fref * 3 (100-240 MHz)
		1	1	1	fref (33-80 MHz)	fref * 3 (100-240 MHz)	fref * 3 \div 2 (50-120 MHz)

1. fref is the input clock reference frequency (CCLK).
2. QAx connected to FB_IN and FSELA=0.
3. QAx connected to FB_IN and FSELA=1.

Table 8. MPC93R52 Example Configurations (F_RANGE = 1)

PLL Feedback	fref ⁽¹⁾ [MHz]	FSELA	FSELB	FSELC	QA[0:4]:fref ratio	QB[0:3]:fref ratio	QC[0:1]:fref ratio
VCO $\div 8$ ⁽²⁾	25-60	0	0	0	fref (25-60 MHz)	fref (25-60 MHz)	fref * 2 (50-120 MHz)
		0	0	1	fref (25-60 MHz)	fref (25-60 MHz)	fref (25-60 MHz)
		1	0	0	fref * 2 \div 3 (16-40 MHz)	fref (25-60 MHz)	fref * 2 (50-120 MHz)
		1	0	1	fref * 2 \div 3 (16-40 MHz)	fref (25-60 MHz)	fref (25-60 MHz)
VCO $\div 12$ ⁽³⁾	16.67–40	1	0	0	fref (16-40 MHz)	fref * 3 \div 2 (25-60 MHz)	fref * 3 (50-120 MHz)
		1	0	1	fref (16-40 MHz)	fref * 3 \div 2 (25-60 MHz)	fref * 3 \div 2 (25-60 MHz)
		1	1	0	fref (16-40 MHz)	fref * 3 (50-120 MHz)	fref * 3 (50-120 MHz)
		1	1	1	fref (16-40 MHz)	fref * 3 (50-120 MHz)	fref * 3 \div 2 (25-60 MHz)

1. fref is the input clock reference frequency (CCLK).
2. QAx connected to FB_IN and FSELA=0.
3. QAx connected to FB_IN and FSELA=1.

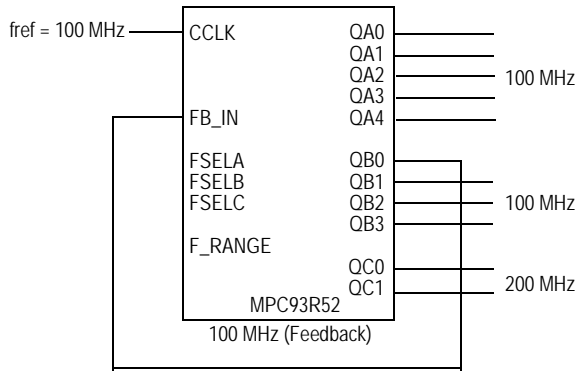
Example Configurations for the MPC93R52

MPC93R52 default configuration (feedback of QB0 = 100 MHz). All control pins are left open.

Frequency range	Min	Max
Input	50 MHz	120 MHz
QA outputs	50 MHz	12 MHz
QB outputs	50 MHz	120 MHz
QC outputs	100 MHz	240 MHz

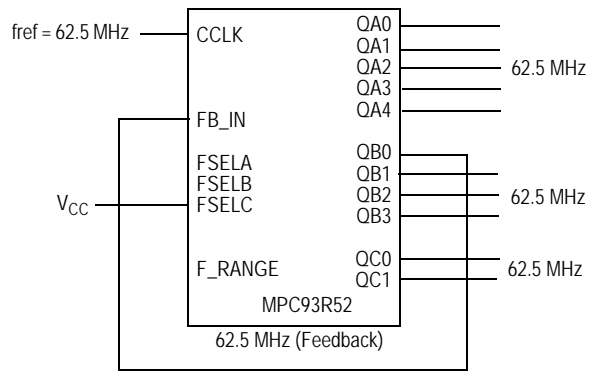
Figure 3. MPC93R52 Default Configuration

MPC93R52 zero-delay (feedback of QB0 = 62.5 MHz). All control pins are left open except FSELB = 1. All outputs are locked in frequency and phase to the input clock.

Frequency range	Min	Max
Input	50 MHz	120 MHz
QA outputs	50 MHz	120 MHz
QB outputs	50 MHz	120 MHz
QC outputs	50 MHz	120 MHz

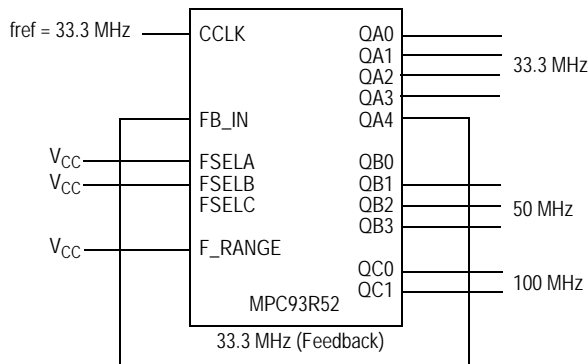
Figure 4. MPC93R52 Zero Delay Buffer Configuration

MPC93R52 configuration to multiply the reference frequency by 3, 3 ÷ 2 and 1. PLL feedback of QA4 = 33.3 MHz.

Frequency range	Min	Max
Input	25 MHz	60 MHz
QA outputs	50 MHz	120 MHz
QB outputs	50 MHz	120 MHz
QC outputs	100 MHz	240 MHz

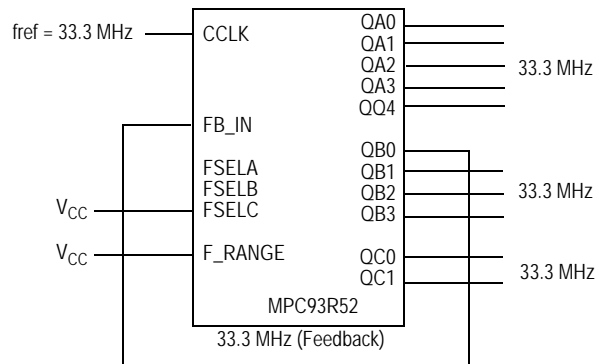
Figure 5. MPC93R52 Default Configuration

MPC93R52 zero-delay (feedback of QB0 = 33.3 MHz). Equivalent to Figure 2 except F_RANGE = 1 enabling a lower input and output clock frequency.

Frequency range	Min	Max
Input	25 MHz	60 MHz
QA outputs	25 MHz	60 MHz
QB outputs	25 MHz	60 MHz
QC outputs	25 MHz	60 MHz

Figure 6. MPC93R52 Zero Delay Buffer Configuration 2

Power Supply Filtering

The MPC93R52 is a mixed analog/digital product. Its analog circuitry is naturally susceptible to random noise, especially if this noise is seen on the power supply pins. Random noise on the V_{CCA} (PLL) power supply impacts the device characteristics, for instance I/O jitter. The MPC93R52 provides separate power supplies for the output buffers (V_{CC}) and the phase-locked loop (V_{CCA}) of the device. The purpose of this design technique is to isolate the high switching noise digital outputs from the relatively sensitive internal analog phase-locked loop. In a digital system environment where it is more difficult to minimize noise on the power supplies a second level of isolation may be required. The simple but effective form of isolation is a power supply filter on the V_{CCA} pin for the MPC93R52. [Figure 7](#) illustrates a typical power supply filter scheme. The MPC93R52 frequency and phase stability is most susceptible to noise with spectral content in the 100 kHz to 20 MHz range. Therefore the filter should be designed to target this range. The key parameter that needs to be met in the final filter design is the DC voltage drop across the series filter resistor R_F . From the data sheet the I_{CCA} current (the current sourced through the V_{CCA} pin) is typically 3 mA (5 mA maximum), assuming that a minimum of 2.98 V must be maintained on the V_{CCA} pin. The resistor R_F shown in [Figure 7](#) should have a resistance of 5-25 Ω to meet the voltage drop criteria.

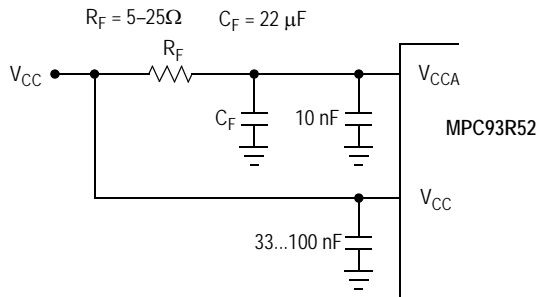

Figure 7. V_{CCA} Power Supply Filter

The minimum values for R_F and the filter capacitor C_F are defined by the required filter characteristics: the RC filter should provide an attenuation greater than 40 dB for noise whose spectral content is above 100 kHz. In the example RC filter shown in [Figure 7](#), the filter cut-off frequency is around 3-5 kHz and the noise attenuation at 100 kHz is better than 42 dB.

As the noise frequency crosses the series resonant point of an individual capacitor its overall impedance begins to look inductive and thus increases with increasing frequency. The parallel capacitor combination shown ensures that a low impedance path to ground exists for frequencies well above the bandwidth of the PLL. Although the MPC93R52 has several design features to minimize the susceptibility to power supply noise (isolated power and grounds and fully differential PLL) there still may be applications in which overall performance is being degraded due to system power supply noise. The power supply filter schemes discussed in this section should be adequate to eliminate power supply noise related problems in most designs.

Using the MPC93R52 in Zero-Delay Applications

Nested clock trees are typical applications for the MPC93R52. Designs using the MPC93R52 as LVCMOS PLL fanout buffer with zero insertion delay will show significantly lower clock skew than clock distributions developed from CMOS fanout buffers. The external feedback option of the MPC93R52 clock driver allows for its use as a zero delay buffer. One example configuration is to use a $\div 4$ output as a feedback to the PLL and configuring all other outputs to a divide-by-4 mode. The propagation delay through the device is virtually eliminated. The PLL aligns the feedback clock output edge with the clock input reference edge resulting a near zero delay through the device. The maximum insertion delay of the device in zero-delay applications is measured between the reference clock input and any output. This effective delay consists of the static phase offset, I/O jitter (phase or long-term jitter), feedback path delay and the output-to-output skew error relative to the feedback output.

Calculation of Part-to-Part Skew

The MPC93R52 zero delay buffer supports applications where critical clock signal timing can be maintained across several devices. If the reference clock inputs of two or more MPC93R52 are connected together, the maximum overall timing uncertainty from the common CCLK input to any output is:

$$t_{SK(PP)} = t_{(\varnothing)} + t_{SK(O)} + t_{PD, LINE(FB)} + t_{JIT(\varnothing)} \cdot CF$$

This maximum timing uncertainty consist of 4 components: static phase offset, output skew, feedback board trace delay and I/O (phase) jitter:

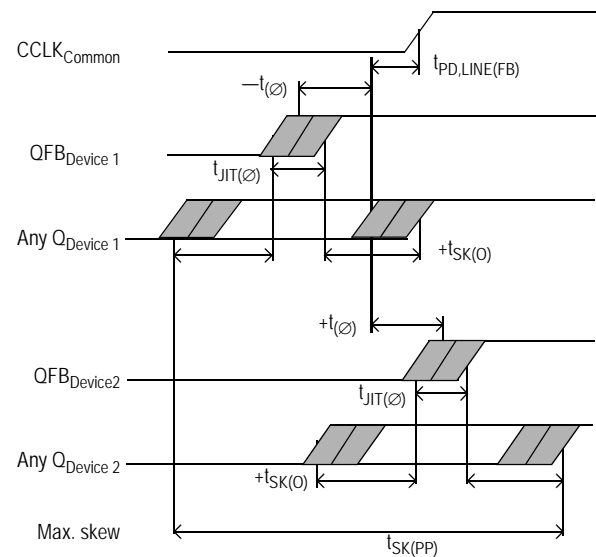

Figure 8. MPC93R52 Max. Device-to-Device Skew

Due to the statistical nature of I/O jitter a RMS value (1σ) is specified. I/O jitter numbers for other confidence factors (CF) can be derived from [Table 9](#).

Table 9. Confidence Factor CF

CF	Probability of clock edge within the distribution
± 1σ	0.68268948
± 2σ	0.95449988
± 3σ	0.99730007
± 4σ	0.99993663
± 5σ	0.99999943
± 6σ	0.99999999

The feedback trace delay is determined by the board layout and can be used to fine-tune the effective delay through each device. In the following example calculation a I/O jitter confidence factor of 99.7% (± 3σ) is assumed, resulting in a worst case timing uncertainty from input to any output of -445 ps to 395 ps relative to CCLK:

$$t_{SK(PP)} = [-200ps...150ps] + [-200ps...200ps] + [(15ps \cdot -3)...(15ps \cdot 3)] + t_{PD, LINE(FB)}$$

$$t_{SK(PP)} = [-445ps...395ps] + t_{PD, LINE(FB)}$$

Due to the frequency dependence of the I/O jitter, [Figure 9](#), can be used for a more precise timing performance analysis.

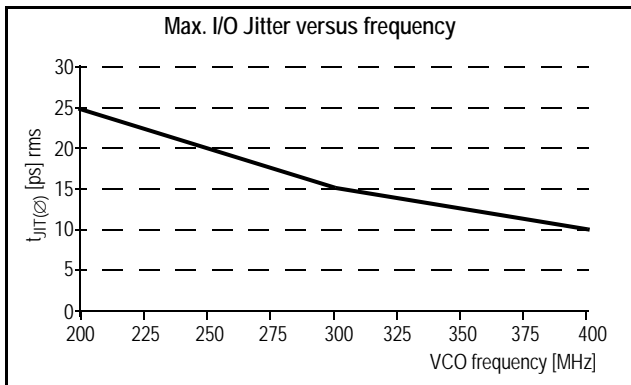

Figure 9. Max. I/O Jitter versus Frequency

Driving Transmission Lines

The MPC93R52 clock driver was designed to drive high speed signals in a terminated transmission line environment. To provide the optimum flexibility to the user the output drivers were designed to exhibit the lowest impedance possible. With an output impedance of less than 20 Ω the drivers can drive either parallel or series terminated transmission lines. For more information on transmission lines the reader is referred to Freescale application note AN1091. In most high performance clock networks point-to-point distribution of signals is the method of choice. In a point-to-point scheme either series terminated or parallel terminated transmission lines can be used. The parallel technique terminates the signal at the end of the line with a 50 Ω resistance to V_{CC}÷2.

This technique draws a fairly high level of DC current and thus only a single terminated line can be driven by each output of the MPC93R52 clock driver. For the series

terminated case however, there is no DC current draw, thus the outputs can drive multiple series terminated lines.

[Figure 10](#) illustrates an output driving a single series terminated line versus two series terminated lines in parallel. When taken to its extreme the fanout of the MPC93R52 clock driver is effectively doubled due to its capability to drive multiple lines.

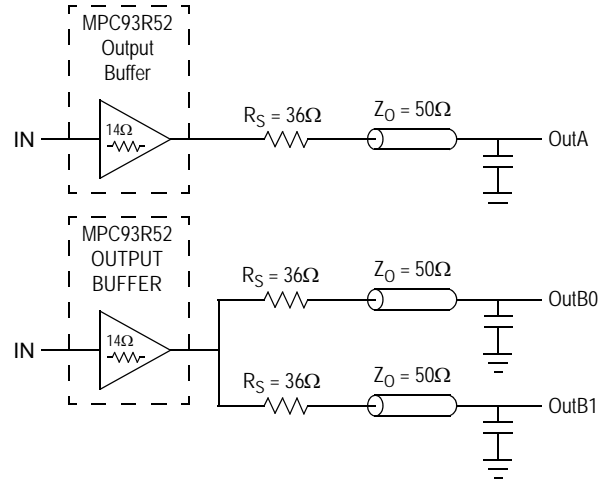

Figure 10. Single versus Dual Transmission Lines

The waveform plots in [Figure 11](#) show the simulation results of an output driving a single line versus two lines. In both cases the drive capability of the MPC93R52 output buffer is more than sufficient to drive 50 Ω transmission lines on the incident edge. Note from the delay measurements in the simulations a delta of only 43 ps exists between the two differently loaded outputs. This suggests the dual line driving need not be used exclusively to maintain the tight output-to-output skew of the MPC93R52. The output waveform in [Figure 11](#) shows a step in the waveform, this step is caused by the impedance mismatch seen looking into the driver. The parallel combination of the 36 Ω series resistor plus the output impedance does not match the parallel combination of the line impedances. The voltage wave launched down the two lines will equal:

$$V_L = V_S (Z_0 \div (R_S + R_0 + Z_0))$$

$$Z_0 = 50 \Omega \parallel 50 \Omega$$

$$R_S = 36 \Omega \parallel 36 \Omega$$

$$R_0 = 14 \Omega$$

$$V_L = 3.0 (25 \div (18 + 17 + 25))$$

$$= 1.31 V$$

At the load end the voltage will double, due to the near unity reflection coefficient, to 2.6 V. It will then increment towards the quiescent 3.0 V in steps separated by one round trip delay (in this case 4.0 ns).

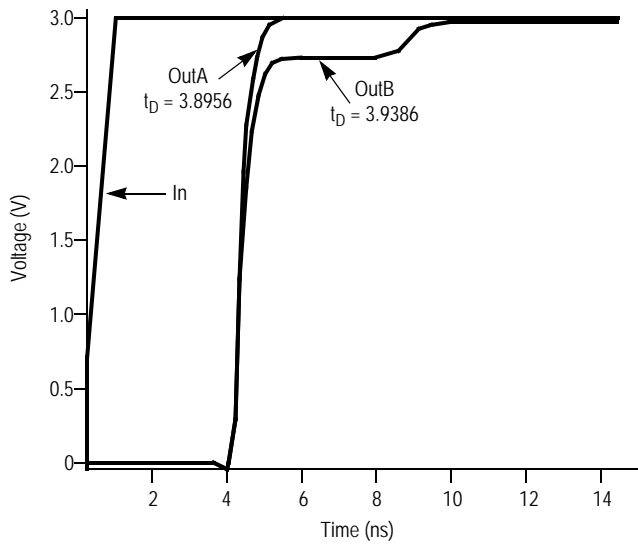

Figure 11. Single versus Dual Waveforms

Since this step is well above the threshold region it will not cause any false clock triggering, however designers may be uncomfortable with unwanted reflections on the line. To better match the impedances when driving multiple lines the situation in Figure 12 should be used. In this case the series terminating resistors are reduced such that when the parallel combination is added to the output buffer impedance the line impedance is perfectly matched.

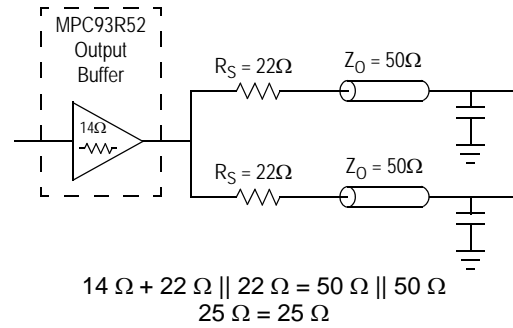

Figure 12. Optimized Dual Line Termination

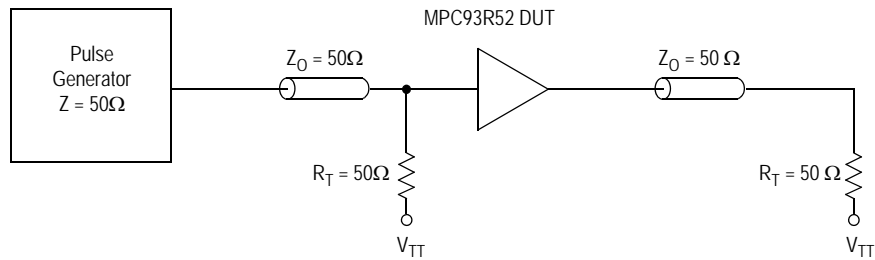
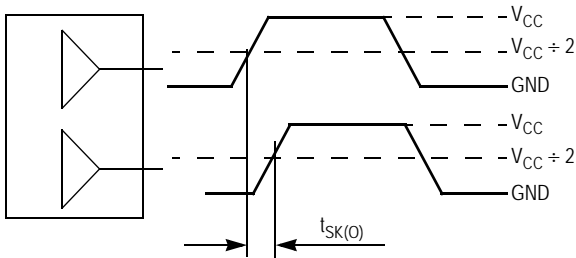

Figure 13. CCLK MPC93R52 AC Test Reference for $V_{CC} = 3.3\text{ V}$ and $V_{CC} = 2.5\text{ V}$



The pin-to-pin skew is defined as the worst case difference in propagation delay between any similar delay path within a single device

Figure 14. Output-to-Output Skew $t_{SK(O)}$

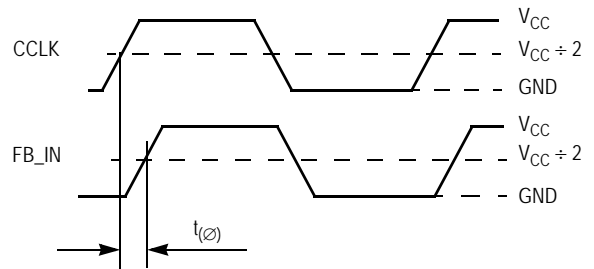
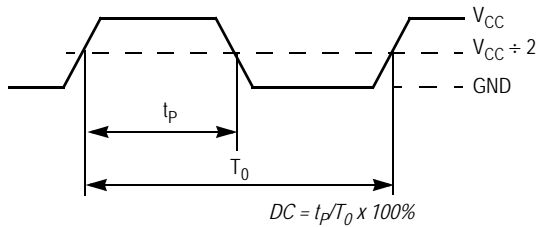
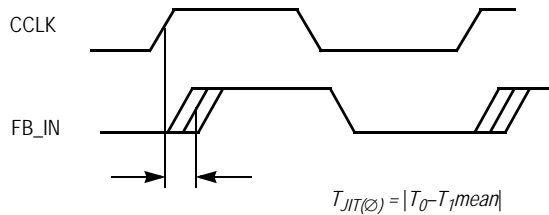

Figure 15. Propagation Delay ($t_{(\phi)}$, static phase offset) Test Reference



The time from the PLL controlled edge to the non controlled edge, divided by the time between PLL controlled edges, expressed as a percentage

Figure 16. Output Duty Cycle (DC)



The deviation in t_0 for a controlled edge with respect to a t_0 mean in a random sample of cycles

Figure 17. I/O Jitter

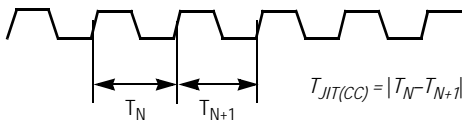

The variation in cycle time of a signal between adjacent cycles, over a random sample of adjacent cycle pairs

Figure 18. Cycle-to-Cycle Jitter

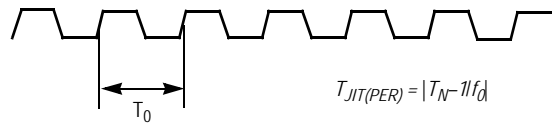

The deviation in cycle time of a signal with respect to the ideal period over a random sample of cycles

Figure 19. Period Jitter

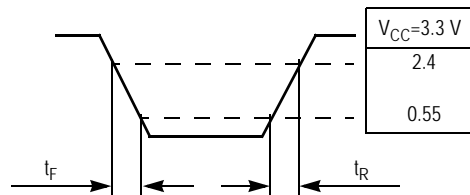

Figure 20. Output Transition Time Test Reference

Revision History Sheet

Rev	Table	Page	Description of Change	Date
5		1	NRND – Not Recommend for New Designs	1/7/13
5		1	Deleted recommended replacement part	1/31/13
6		1	Removed NRND and updated data sheet format	3/18/15



Corporate Headquarters
6024 Silver Creek Valley Road
San Jose, CA 95138 USA

Sales
1-800-345-7015 or 408-284-8200
Fax: 408-284-2775
www.IDT.com

Tech Support
email: clocks@idt.com

DISCLAIMER Integrated Device Technology, Inc. (IDT) and its subsidiaries reserve the right to modify the products and/or specifications described herein at any time and at IDT's sole discretion. All information in this document, including descriptions of product features and performance, is subject to change without notice. Performance specifications and the operating parameters of the described products are determined in the independent state and are not guaranteed to perform the same way when installed in customer products. The information contained herein is provided without representation or warranty of any kind, whether express or implied, including, but not limited to, the suitability of IDT's products for any particular purpose, an implied warranty of merchantability, or non-infringement of the intellectual property rights of others. This document is presented only as a guide and does not convey any license under intellectual property rights of IDT or any third parties.

IDT's products are not intended for use in applications involving extreme environmental conditions or in life support systems or similar devices where the failure or malfunction of an IDT product can be reasonably expected to significantly affect the health or safety of users. Anyone using an IDT product in such a manner does so at their own risk, absent an express, written agreement by IDT.

While the information presented herein has been checked for both accuracy and reliability, Integrated Device Technology (IDT) assumes no responsibility for either its use or for the infringement of any patents or other rights of third parties, which would result from its use. No other circuits, patents, or licenses are implied. This product is intended for use in normal commercial applications. Any other applications, such as those requiring extended temperature ranges, high reliability or other extraordinary environmental requirements are not recommended without additional processing by IDT. IDT reserves the right to change any circuitry or specifications without notice. IDT does not authorize or warrant any IDT product for use in life support devices or critical medical instruments.

Integrated Device Technology, IDT and the IDT logo are registered trademarks of IDT. Product specification subject to change without notice. Other trademarks and service marks used herein, including protected names, logos and designs, are the property of IDT or their respective third party owners.

Copyright ©2015 Integrated Device Technology, Inc.. All rights reserved.



Компания «ЭлектроПласт» предлагает заключение долгосрочных отношений при поставках импортных электронных компонентов на взаимовыгодных условиях!

Наши преимущества:

- Оперативные поставки широкого спектра электронных компонентов отечественного и импортного производства напрямую от производителей и с крупнейших мировых складов;
- Поставка более 17-ти миллионов наименований электронных компонентов;
- Поставка сложных, дефицитных, либо снятых с производства позиций;
- Оперативные сроки поставки под заказ (от 5 рабочих дней);
- Экспресс доставка в любую точку России;
- Техническая поддержка проекта, помощь в подборе аналогов, поставка прототипов;
- Система менеджмента качества сертифицирована по Международному стандарту ISO 9001;
- Лицензия ФСБ на осуществление работ с использованием сведений, составляющих государственную тайну;
- Поставка специализированных компонентов (Xilinx, Altera, Analog Devices, Intersil, Interpoint, Microsemi, Aeroflex, Peregrine, Syfer, Eurofarad, Texas Instrument, Miteq, Cobham, E2V, MA-COM, Hittite, Mini-Circuits, General Dynamics и др.);

Помимо этого, одним из направлений компании «ЭлектроПласт» является направление «Источники питания». Мы предлагаем Вам помощь Конструкторского отдела:

- Подбор оптимального решения, техническое обоснование при выборе компонента;
- Подбор аналогов;
- Консультации по применению компонента;
- Поставка образцов и прототипов;
- Техническая поддержка проекта;
- Защита от снятия компонента с производства.



Как с нами связаться

Телефон: 8 (812) 309 58 32 (многоканальный)

Факс: 8 (812) 320-02-42

Электронная почта: org@eplast1.ru

Адрес: 198099, г. Санкт-Петербург, ул. Калинина, дом 2, корпус 4, литера А.