



## FEATURES

- LVPECL or LVDS input to 22 LVPECL outputs
- 100K ECL compatible outputs
- LVDS input includes 100Ω termination
- Guaranteed AC parameters over voltage:
  - > 2GHz  $f_{MAX}$  (toggle)
  - < 35ps max. ch-ch skew
- Low voltage operation: 2.5V, 3.3V
- Temperature range: -40°C to +85°C
- Output enable pin
- Available in a 64-Pin EPAD-TQFP

## APPLICATIONS

- High-performance PCs
- Workstations
- Parallel processor-based systems
- Other high-performance computing
- Communications



Precision Edge®

## DESCRIPTION

The SY89825U is a High Performance Bus Clock Driver with 22 differential LVPECL output pairs. This part is designed for use in low voltage (2.5V, 3.3V) applications which require a large number of outputs to drive precisely aligned, ultra low skew signals to their destination. The input is multiplexed from either LVDS or LVPECL by the CLK\_SEL pin. The LVDS input includes a 100Ω internal termination, thus eliminating the need for external termination. The Output Enable (OE) is synchronous so that the outputs will only be enabled/disabled when they are already in the LOW state. This eliminates any chance of generating a runt clock pulse when the device is enabled/disabled as can happen with an asynchronous control.

The SY89825U features low pin-to-pin skew (35ps max.) —performance previously unachievable in a standard product having such a high number of outputs. The SY89825U is available in a single space saving package which provides a lower overall cost solution. In addition, a single chip solution improves timing budgets by eliminating the multiple device solution with their corresponding large part-to-part skew.

**PACKAGE/ORDERING INFORMATION**

**Ordering Information<sup>(1)</sup>**

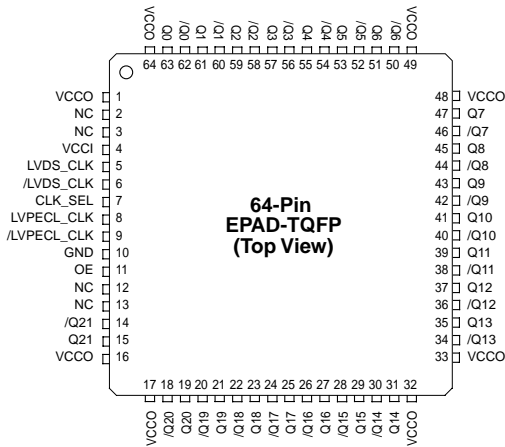

**64-Pin EPAD-TQFP (H64-1)**

| Part Number                   | Package Type | Operating Range | Package Marking                            | Lead Finish      |
|-------------------------------|--------------|-----------------|--|------------------|
| SY89825UHI                    | H64-1        | Industrial      | SY89825UHI                                 | Sn-Pb            |
| SY89825UHITR <sup>(2)</sup>   | H64-1        | Industrial      | <b>SY89825UHI</b>                          | <b>SN-PB</b>     |
| SY89825UHY <sup>(3)</sup>     | H64-1        | Industrial      | SY89825UHY with Pb-Free bar-line indicator | Pb-Free Matte-Sn |
| SY89825UHYTR <sup>(2,3)</sup> | H64-1        | Industrial      | SY89825UHY with Pb-Free bar-line indicator | Pb-Free Matte-Sn |

**Notes:**

1. Contact factory for die availability. Dice are guaranteed at T<sub>A</sub> = 25°C, DC electricals only.
2. Tape and Reel.
3. Pb-Free package recommended for new designs.

**PIN NAMES**

| Pin   | Function   |
|---|--|
| LVDS_CLK, /LVDS_CLK   | Differential LVDS Inputs (Internal 100Ω termination included)  |
| LVPECL_CLK, /LVPECL_CLK   | Differential LVPECL Inputs.  |
| CLK_SEL   | Input CLK Select (LVTTTL)  |
| OE  | Output Enable (LVTTTL)   |
| Q <sub>0</sub> - Q <sub>21</sub> , /Q <sub>0</sub> - /Q <sub>21</sub> | Differential LVPECL Outputs. Terminate with 50Ω to V <sub>CC</sub> -2V   |
| GND   | Ground   |
| V <sub>CCI</sub>  | Power Supply. Connect to V <sub>CC</sub> on PCB. V <sub>CCI</sub> and V <sub>CCO</sub> are not internally connected                    |
| V <sub>CCO</sub>  | Power Supply for Output Buffer. Connect to V <sub>CCI</sub> on PCB. V <sub>CCI</sub> and V <sub>CCO</sub> are not internally connected |

**LOGIC SYMBOL**

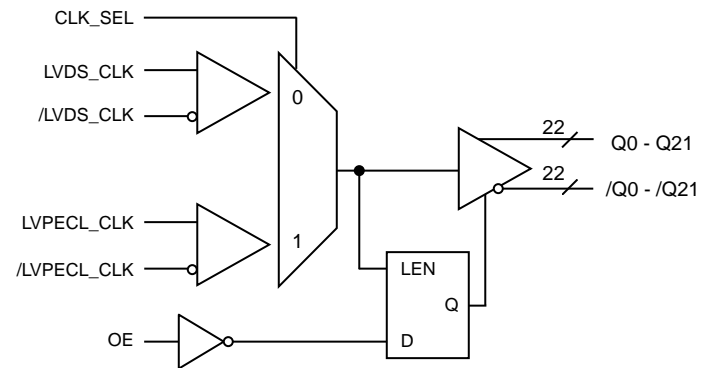

**TRUTH TABLE**

| OE <sup>(1)</sup> | CLK_SEL | Q <sub>0</sub> – Q <sub>21</sub> | /Q <sub>0</sub> – /Q <sub>21</sub> |
|-------------------|---------|----------------------------------|------------------------------------|
| 0                 | 0       | LOW                              | HIGH                               |
| 0                 | 1       | LOW                              | HIGH                               |
| 1                 | 0       | LVDS_CLK                         | /LVDS_CLK                          |
| 1                 | 1       | LVPECL_CLK                       | /LVPECL_CLK                        |

**SIGNAL GROUPS**

| Signal  | I/O    | Level         |
|---|--------|---------------|
| LVDS_CLK, /LVDS_CLK   | Input  | LVDS          |
| Q <sub>0</sub> – Q <sub>21</sub> , /Q <sub>0</sub> – /Q <sub>21</sub> | Output | LVPECL        |
| LVPECL_CLK, /LVPECL_CLK   | Input  | LVPECL        |
| CLK_SEL, OE   | Input  | LVC MOS/LVTTL |

**NOTE:**

- The OE (output enable) signal is synchronized with the low level of the LVDS\_CLK and LVPECL\_CLK signal.

**ABSOLUTE MAXIMUM RATINGS<sup>(1)</sup>**

| Symbol                             | Rating   | Value                         | Unit |      |
|------------------------------------|--|-------------------------------|------|------|
| V <sub>CCI</sub> /V <sub>CCO</sub> | V <sub>CC</sub> Pin Potential to Ground Pin      | –0.5 to +4.0                  | V    |      |
| V <sub>IN</sub>                    | Input Voltage                                    | –0.5 to V <sub>CCI</sub>      | V    |      |
| I <sub>OUT</sub>                   | DC Output Current                                | –50                           | mA   |      |
| T <sub>store</sub>                 | Storage Temperature                              | –65 to +150                   | °C   |      |
| θ <sub>JA</sub>                    | Package Thermal Resistance (Junction-to-Ambient) |                               |      |      |
|                                    | With exposed pad soldered to GND                 | – Still-Air (multi-layer PCB) | 23   | °C/W |
|                                    |  | – 200lfpm (multi-layer PCB)   | 18   | °C/W |
|                                    |  | – 500lfpm (multi-layer PCB)   | 15   | °C/W |
|                                    | Exposed pad <i>not</i> soldered to GND           | – Still-Air (multi-layer PCB) | 44   | °C/W |
|                                    |  | – 200lfpm (multi-layer PCB)   | 36   | °C/W |
| – 500lfpm (multi-layer PCB)        |  | 30                            | °C/W |      |
| θ <sub>JC</sub>                    | Package Thermal Resistance (Junction-to-Case)    | 4.3                           | °C/W |      |

**NOTE:**

- Permanent device damage may occur if ABSOLUTE MAXIMUM RATINGS are exceeded. This is a stress rating only and functional operation is not implied at conditions other than those detailed in the operational sections of this data book. Exposure to ABSOLUTE MAXIMUM RATING conditions for extended periods may affect device reliability.

**DC ELECTRICAL CHARACTERISTICS****Power Supply**

| Symbol                                 | Parameter                           | T <sub>A</sub> = -40°C |      |      | T <sub>A</sub> = +25°C |      |      | T <sub>A</sub> = +85°C |      |      | Unit |
|--|-------------------------------------|------------------------|------|------|------------------------|------|------|------------------------|------|------|------|
|  |                                     | Min.                   | Typ. | Max. | Min.                   | Typ. | Max. | Min.                   | Typ. | Max. |      |
| V <sub>CCI</sub> ,<br>V <sub>CCO</sub> | Power Supply <sup>(1)</sup>         | 2.37                   | —    | 3.6  | 2.37                   | —    | 3.8  | 2.37                   | —    | 3.6  | V    |
| I <sub>CC</sub>                        | Total Supply Current <sup>(2)</sup> | —                      | 100  | 150  | —                      | 100  | 150  | —                      | 100  | 150  | mA   |

**Notes:**

- V<sub>CCI</sub> and V<sub>CCO</sub> must be connected together on the PCB such that they remain at the same potential. V<sub>CCI</sub> and V<sub>CCO</sub> are not internally connected on the die.
- No load. Outputs floating.

**LVDS Input (V<sub>CC</sub> = 2.37V to 3.6V, GND = 0V)**

| Symbol          | Parameter   | T <sub>A</sub> = -40°C |      |      | T <sub>A</sub> = +25°C |      |      | T <sub>A</sub> = +85°C |      |      | Unit |
|-----------------|---|------------------------|------|------|------------------------|------|------|------------------------|------|------|------|
|                 |   | Min.                   | Typ. | Max. | Min.                   | Typ. | Max. | Min.                   | Typ. | Max. |      |
| V <sub>IN</sub> | Input Voltage Range   | 0                      | —    | 2.4  | 0                      | —    | 2.4  | 0                      | —    | 2.4  | V    |
| V <sub>ID</sub> | Differential Input Swing                                      | 100                    | —    | —    | 100                    | —    | —    | 100                    | —    | —    | mV   |
| I <sub>IL</sub> | Input Low Current <sup>(1)</sup>                              | -1.25                  | —    | —    | -1.25                  | —    | —    | -1.25                  | —    | —    | mA   |
| R <sub>IN</sub> | LVDS Differential Input Resistance<br>(LVDS_CLK to /LVDS_CLK) | 80                     | 100  | 120  | 80                     | 100  | 120  | 80                     | 100  | 120  | Ω    |

**Note:**

- For I<sub>IL</sub>, both LVDS inputs are grounded.

**LVPECL Input/Output (V<sub>CC</sub> = 2.37V to 3.6V, GND = 0V)**

| Symbol           | Parameter  | T <sub>A</sub> = -40°C   |                          | T <sub>A</sub> = +25°C   |                          | T <sub>A</sub> = +85°C   |                          | Unit |
|------------------|--|--------------------------|--------------------------|--------------------------|--------------------------|--------------------------|--------------------------|------|
|                  |  | Min.                     | Max.                     | Min.                     | Max.                     | Min.                     | Max.                     |      |
| V <sub>IH</sub>  | Input HIGH Voltage<br>(Single ended)             | V <sub>CC</sub> - 1.165  | V <sub>CC</sub> - 0.88   | V <sub>CC</sub> - 1.165  | V <sub>CC</sub> - 0.88   | V <sub>CC</sub> - 1.165  | V <sub>CC</sub> - 0.88   | V    |
| V <sub>IL</sub>  | Input LOW Voltage                                | V <sub>CC</sub> - 1.945  | V <sub>CC</sub> - 1.625  | V <sub>CC</sub> - 1.945  | V <sub>CC</sub> - 1.625  | V <sub>CC</sub> - 1.945  | V <sub>CC</sub> - 1.625  | V    |
| V <sub>PP</sub>  | Minimum Input Swing <sup>(1)</sup><br>LVPECL_CLK | 600                      | —                        | 600                      | —                        | 600                      | —                        | mV   |
| V <sub>CMR</sub> | Common Mode Range <sup>(2)</sup><br>LVPECL_CLK   | -1.5                     | -0.4                     | -1.5                     | -0.4                     | -1.5                     | -0.4                     | V    |
| V <sub>OH</sub>  | Output HIGH Voltage <sup>(3)</sup>               | V <sub>CCO</sub> - 1.085 | V <sub>CCO</sub> - 0.880 | V <sub>CCO</sub> - 1.025 | V <sub>CCO</sub> - 0.880 | V <sub>CCO</sub> - 1.025 | V <sub>CCO</sub> - 0.880 | V    |
| V <sub>OL</sub>  | Output LOW Voltage <sup>(3)</sup>                | V <sub>CCO</sub> - 1.830 | V <sub>CCO</sub> - 1.555 | V <sub>CCO</sub> - 1.810 | V <sub>CCO</sub> - 1.620 | V <sub>CCO</sub> - 1.810 | V <sub>CCO</sub> - 1.620 | V    |
| I <sub>IH</sub>  | Input HIGH Current                               | —                        | 150                      | —                        | 150                      | —                        | 150                      | μA   |
| I <sub>IL</sub>  | Input LOW Current                                | 0.5                      | —                        | 0.5                      | —                        | 0.5                      | —                        | μA   |

**Notes:**

- The V<sub>PP</sub> (min.) is defined as the minimum input differential voltage which will cause no increase in the propagation delay.
- V<sub>CMR</sub> is defined as the range within which the V<sub>IH</sub> level may vary, with the device still meeting the propagation delay specification. The numbers in the table are referenced to V<sub>CCI</sub>. The V<sub>IL</sub> level must be such that the peak-to-peak voltage is less than 1.0V and greater than or equal to V<sub>PP</sub> (min.). The lower end of the CMR range varies 1:1 with V<sub>CCI</sub>. The V<sub>CMR</sub> (min) will be fixed at 3.3V - |V<sub>CMR</sub> (min)|.
- Outputs loaded with 50Ω to V<sub>CC</sub> - 2V.

**LVC MOS/LVTTL Control Inputs (OE, CLK\_SEL) (V<sub>CC</sub> = 2.37V to 3.6V, GND = 0V)**

| Symbol          | Parameter          | T <sub>A</sub> = -40°C |      |      | T <sub>A</sub> = +25°C |      |      | T <sub>A</sub> = +85°C |      |      | Unit |
|-----------------|--------------------|------------------------|------|------|------------------------|------|------|------------------------|------|------|------|
|                 |                    | Min.                   | Typ. | Max. | Min.                   | Typ. | Max. | Min.                   | Typ. | Max. |      |
| V <sub>IH</sub> | Input HIGH Voltage | 2.0                    | —    | —    | 2.0                    | —    | —    | 2.0                    | —    | —    | V    |
| V <sub>IL</sub> | Input LOW Voltage  | —                      | —    | 0.8  | —                      | —    | 0.8  | —                      | —    | 0.8  | V    |
| I <sub>IH</sub> | Input HIGH Current | +20                    | —    | -250 | +20                    | —    | -250 | +20                    | —    | -250 | μA   |
| I <sub>IL</sub> | Input LOW Current  | —                      | —    | -600 | —                      | —    | -600 | —                      | —    | -600 | μA   |

**AC ELECTRICAL CHARACTERISTICS<sup>(1)</sup>**

V<sub>CC</sub> = 2.37V to 3.6V, GND = 0V

| Symbol                               | Parameter  | T <sub>A</sub> = -40°C |      |      | T <sub>A</sub> = +25°C |       |      | T <sub>A</sub> = +85°C |      |      | Unit                |
|--------------------------------------|--|------------------------|------|------|------------------------|-------|------|------------------------|------|------|---------------------|
|                                      |  | Min.                   | Typ. | Max. | Min.                   | Typ.  | Max. | Min.                   | Typ. | Max. |                     |
| f <sub>MAX</sub>                     | Max Toggle Frequency <sup>(2)</sup>                | 2                      | —    | —    | 2                      | —     | —    | 2                      | —    | —    | GHz                 |
| t <sub>PHL</sub><br>t <sub>PLH</sub> | Propagation Delay<br>(Differential) <sup>(3)</sup> |                        |      |      |                        |       |      |                        |      |      | ns                  |
|                                      | LVPECL IN  | 0.600                  | —    | 1.2  | 0.600                  | 0.900 | 1.2  | 0.600                  | —    | 1.2  |                     |
|                                      | LVDS IN  | 0.800                  | —    | 1.4  | 0.800                  | 1.1   | 1.4  | 0.800                  | —    | 1.4  |                     |
| t <sub>SKREW</sub>                   | Within-Device Skew <sup>(4)</sup>                  | —                      | —    | 35   | —                      | 20    | 35   | —                      | —    | 35   | ps                  |
|                                      | Part-to-Part Skew <sup>(5)</sup>                   | —                      | 100  | 200  | —                      | 100   | 200  | —                      | 100  | 200  | ps                  |
| t <sub>S(OE)</sub>                   | OE Set-Up Time <sup>(6)</sup>                      | 1.0                    | —    | —    | 1.0                    | —     | —    | 1.0                    | —    | —    | ns                  |
| t <sub>H(OE)</sub>                   | OE Hold Time <sup>(6)</sup>                        | 0.5                    | —    | —    | 0.5                    | —     | —    | 0.5                    | —    | —    | ns                  |
| t <sub>JITTER</sub>                  | Random Jitter <sup>(7)</sup>                       | —                      | —    | 1    | —                      | —     | 1    | —                      | —    | 1    | ps <sub>(RMS)</sub> |
|                                      | Cycle-to-Cycle Jitter <sup>(8)</sup>               | —                      | —    | 1    | —                      | —     | 1    | —                      | —    | 1    | ps <sub>(RMS)</sub> |
|                                      | Total Jitter <sup>(9)</sup>                        | —                      | —    | 10   | —                      | —     | 10   | —                      | —    | 10   | ps <sub>(PP)</sub>  |
| t <sub>r</sub><br>t <sub>f</sub>     | Output Rise/Fall Time<br>(20% – 80%)               | 300                    | —    | 600  | 300                    | 450   | 600  | 300                    | —    | 600  | ps                  |
| t <sub>(switchover)</sub>            | Input Switchover<br>CLK_SEL-to-valid output        | —                      | —    | 1.2  | —                      | —     | 1.2  | —                      | —    | 1.2  | ns                  |

**Notes:**

1. Outputs loaded with 50Ω to V<sub>CC</sub> – 2V. Airflow ≥ 300lfpm.
2. f<sub>MAX</sub> is defined as the maximum toggle frequency measured. Measured with a 750mV input signal, all loading with 50Ω to V<sub>CC</sub> – 2V.
3. Differential propagation delay is defined as the delay from the crossing point of the differential input signals to the crossing point of the differential output signals.
4. The within-device skew is defined as the worst case difference between any two similar delay paths within a single device operating at the same voltage and temperature.
5. The part-to-part skew is defined as the absolute worst case difference between any two delay paths on any two devices operating at the same voltage and temperature. Part-to-part skew is the total skew difference; pin-to-pin skew + part-to-part skew.
6. Set-up and hold time applies to synchronous applications that intend to enable/disable before the next clock cycle. For asynchronous applications, set-up and hold time does not apply. OE set-up time is defined with respect to the rising edge of the clock. OE HIGH to LOW transition ensures outputs remain disabled during the next clock cycle. OE LOW to HIGH transition enables normal operation of the next input clock.
7. Random jitter is measured using K28.7 pattern, measured at ≤ f<sub>MAX</sub>.
8. Cycle-to-cycle definition: the variation of periods between adjacent cycles, T<sub>n</sub>–T<sub>n-1</sub> where T is the time between rising edges of the output signal.
9. Total jitter definition: with an ideal clock input of frequency ≤ f<sub>MAX</sub>, no more than one output edge in 10<sup>20</sup> output edges will deviate by more than the specified peak-to-peak jitter value.

## LVDS/LVPECL INPUTS

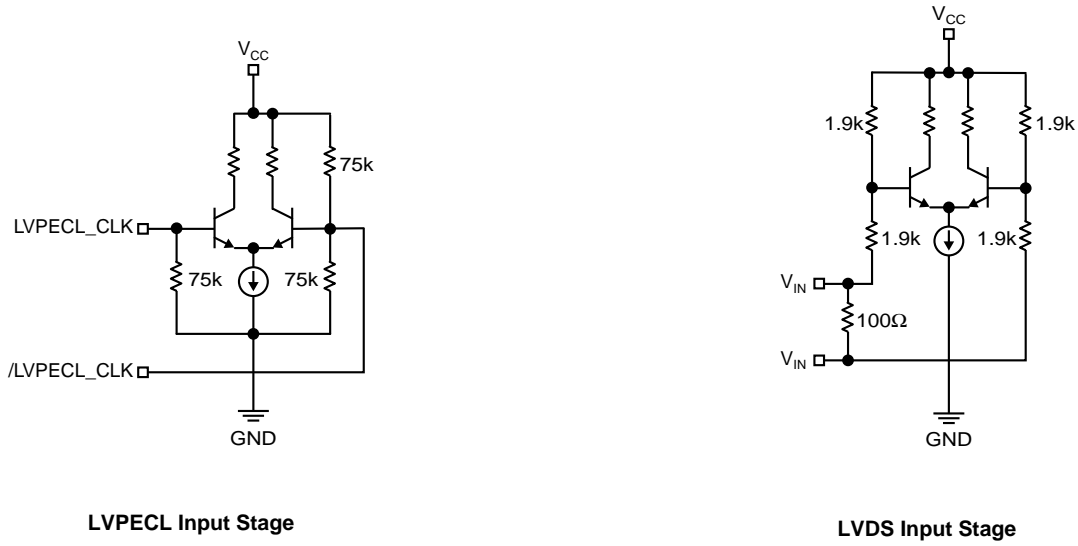
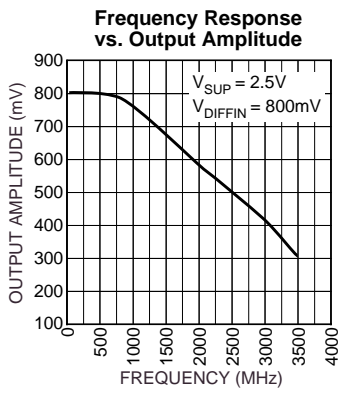
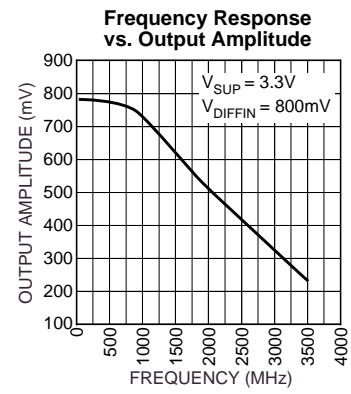

Figure 1. Simplified LVPECL & LVDS Input Stage

## TYPICAL CHARACTERISTICS



**Frequency Response vs. Output Amplitude @2.5V**



**Frequency Response vs. Output Amplitude @3.3V**

**LVPECL TERMINATION RECOMMENDATIONS**

**Output Considerations**

Be sure to properly terminate all outputs as shown below, or equivalent. For AC coupled applications, be sure to include a pull

down resistor at the output of each driver. The emitter follower outputs requires a DC current path to GND. Unused outputs can be left floating with minimal impact on skew and jitter.

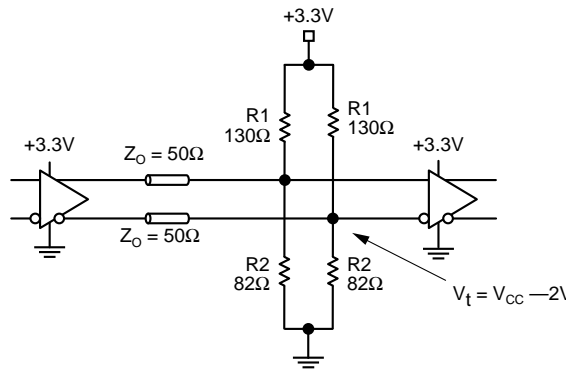

**Figure 1. Parallel Termination-Thevenin Equivalent**

**Notes:**

- 1. For +2.5V systems:  
R1 = 250Ω  
R2 = 62.5Ω

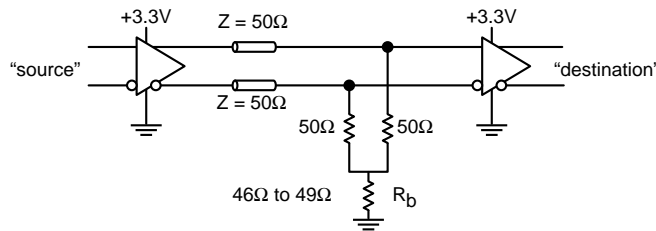

**Figure 2. Three-Resistor "Y-Termination"**

**Notes:**

- 1. Power-saving alternative to Thevenin termination.
- 2. Place termination resistors as close to destination inputs as possible.
- 3. R<sub>b</sub> resistor sets the DC bias voltage equal to V<sub>t</sub>. For +3.3V systems R<sub>b</sub> = 46Ω to 49Ω.
- 4. Precision, low-cost 3-Resistor networks are available from resistor manufacturers such as Thin Film Technology ([www.thinfilm.com](http://www.thinfilm.com)).



**64-PIN EPAD-TQFP (DIE UP) (H64-1)**

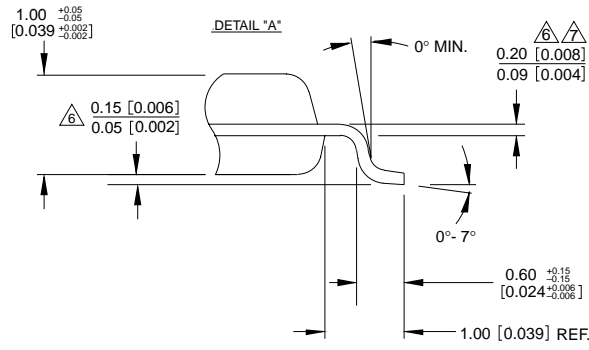
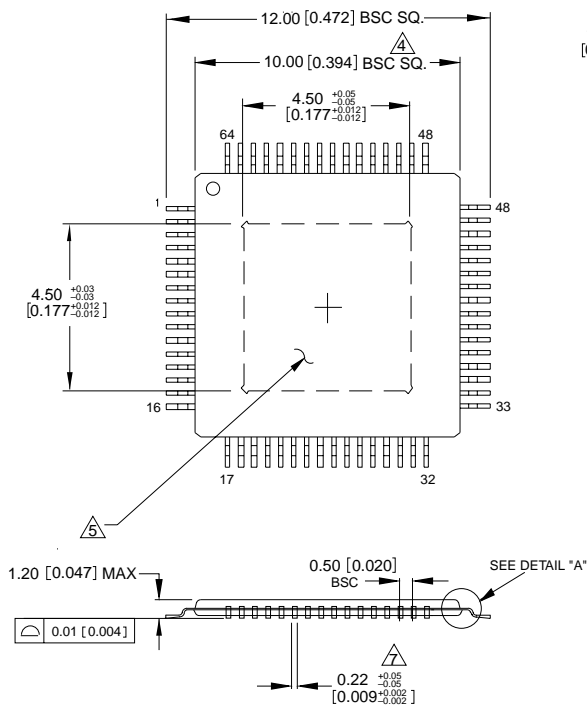

- NOTES:**
1. DIMENSIONS ARE IN MM[INCHES].
  2. CONTROLLING DIMENSION: MM.
  3. EXPOSED PAD: Cu WITH Sn/Pb PLATING.
  - △ DIMENSION DOES NOT INCLUDE MOLD FLASH OF 0.254[0.010] MAX.
  - △ DIE UP ORIENTATION SHOWN. EXPOSED PAD IS VISIBLE FROM BOTTOM OF PACKAGE.
  - △ MAXIMUM AND MINIMUM SPECIFICATIONS ARE INDICATED AS FOLLOWS:  $\frac{\text{MAX}}{\text{MIN}}$
  - △ THIS DIMENSION INCLUDES LEAD FINISH.

Rev. 03

**MICREL, INC. 2180 FORTUNE DRIVE SAN JOSE, CA 95131 USA**

TEL + 1 (408) 944-0800 FAX + 1 (408) 474-1000 WEB <http://www.micrel.com>

The information furnished by Micrel in this data sheet is believed to be accurate and reliable. However, no responsibility is assumed by Micrel for its use. Micrel reserves the right to change circuitry and specifications at any time without notification to the customer.

Micrel Products are not designed or authorized for use as components in life support appliances, devices or systems where malfunction of a product can reasonably be expected to result in personal injury. Life support devices or systems are devices or systems that (a) are intended for surgical implant into the body or (b) support or sustain life, and whose failure to perform can be reasonably expected to result in a significant injury to the user. A Purchaser's use or sale of Micrel Products for use in life support appliances, devices or systems is at Purchaser's own risk and Purchaser agrees to fully indemnify

Micrel for any damages resulting from such use or sale.

© 2005 Micrel, Incorporated.



Компания «ЭлектроПласт» предлагает заключение долгосрочных отношений при поставках импортных электронных компонентов на взаимовыгодных условиях!

Наши преимущества:

- Оперативные поставки широкого спектра электронных компонентов отечественного и импортного производства напрямую от производителей и с крупнейших мировых складов;
- Поставка более 17-ти миллионов наименований электронных компонентов;
- Поставка сложных, дефицитных, либо снятых с производства позиций;
- Оперативные сроки поставки под заказ (от 5 рабочих дней);
- Экспресс доставка в любую точку России;
- Техническая поддержка проекта, помощь в подборе аналогов, поставка прототипов;
- Система менеджмента качества сертифицирована по Международному стандарту ISO 9001;
- Лицензия ФСБ на осуществление работ с использованием сведений, составляющих государственную тайну;
- Поставка специализированных компонентов (Xilinx, Altera, Analog Devices, Intersil, Interpoint, Microsemi, Aeroflex, Peregrine, Syfer, Eurofarad, Texas Instrument, Miteq, Cobham, E2V, MA-COM, Hittite, Mini-Circuits, General Dynamics и др.);

Помимо этого, одним из направлений компании «ЭлектроПласт» является направление «Источники питания». Мы предлагаем Вам помощь Конструкторского отдела:

- Подбор оптимального решения, техническое обоснование при выборе компонента;
- Подбор аналогов;
- Консультации по применению компонента;
- Поставка образцов и прототипов;
- Техническая поддержка проекта;
- Защита от снятия компонента с производства.



#### Как с нами связаться

**Телефон:** 8 (812) 309 58 32 (многоканальный)

**Факс:** 8 (812) 320-02-42

**Электронная почта:** [org@eplast1.ru](mailto:org@eplast1.ru)

**Адрес:** 198099, г. Санкт-Петербург, ул. Калинина, дом 2, корпус 4, литера А.