



### Description

The Natural gas module is a battery operated detection device designed for detection of natural gas (methane) in concentrations below 100% LEL (4.4% CH<sub>4</sub> in air).

The sensor is equipped with test button as well as an audible alarm option realized with embedded buzzer.

The heart of the device is an SGX patented MEMS pellistor sensor which allows for low power operation on standard AA type batteries.

The module is equipped with visual (LED's) and audible (buzzer) alarms to inform of potential gas leakage as well as transmit data related to actual state of the module and concentration of gas if the module is connected to external receiver working with serial RS232 standard.

The estimated maintenance-free operation on 2xAA (2600mAh) batteries is 6 months.

### Power consumption

The typical power consumption of the module is <0.6mA on average, with 50mA peak power consumption at 3V power supply.

### Module operation

The Natural gas module monitors the concentration of methane in air atmosphere. Sensor operates in pulse mode measuring actual concentration of gas during 1 second with 20 seconds intervals.

The sensor is equipped with buzzer and diode indicators.

Depending on actual gas concentration the sensor behaves as indicated in table below:

Gas concentration	Module behavior
< I alarm level (normal state)	Green LED blinking
< II alarm level	Red LED blinking
> II alarm level	Red LED lit all the time + audible sound via buzzer

The module is equipped with „TEST” button which allows for triggering of alarm thus providing the means to test the alarming circuitry operation.

### RS232 communication

In addition to visual and audible communication the module allows to monitor the operation using RS232 terminals. Each 21 seconds the module transmits the measurements data.

The RS232 communication channel also provides means to calibrate the sensor.

### Transmission parameters

Baud rate	115200bps
Parity	8N1

### Functionality

In battery mode the sensor sends data through RS232 interface providing one way transmission only (sensor -> PC).

Any bi-directional communication can be realized using USB connector (sensor should be detached from battery and connected to PC with installed terminal). In this mode the module is always in an online state, while measurements are transmitted each 21 seconds (like in battery operation).

The Natural Gas Module allows for the following functionality with RS232 communication:

1. Calibration of zero level and gas sensitivity.
2. Setting up of first alarm threshold.
3. Setting up of calibration concentration.
4. Recalling and saving of calibration coefficients.

Please refer to Natural gas module application note for detailed information on protocol used.

### TECHNICAL PARAMETERS

Detectable gases	methane
Maximum concentration	5% v/v.
Sensor sensitivity	>10 mV/% CH <sub>4</sub>
Sensor response time	<30 s
Zero drift	<0.1%v/v /month
Sensitivity drift	<0.1%v/v /month
Power supply	5V DC when connected to USB port 3V DC when operated from battery.
Suggested batteries	2x1.5V AA in series (min. 2600mAh)
Operating current	<0,6mA <sub>avg</sub> (battery operated)
Transmission	USB (RS232, CDC Class)
Weight	11 g

Dimensions [w x l x h]	30 x 65 x 9 mm
------------------------	----------------

**Main components**

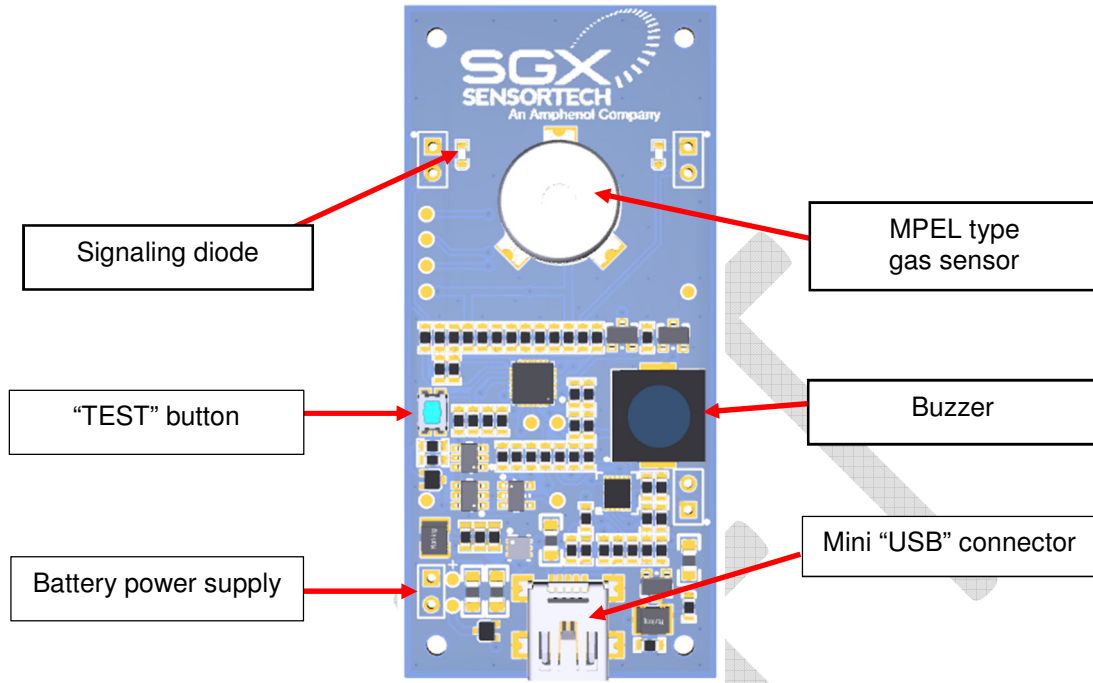

**Mechanical dimensions**

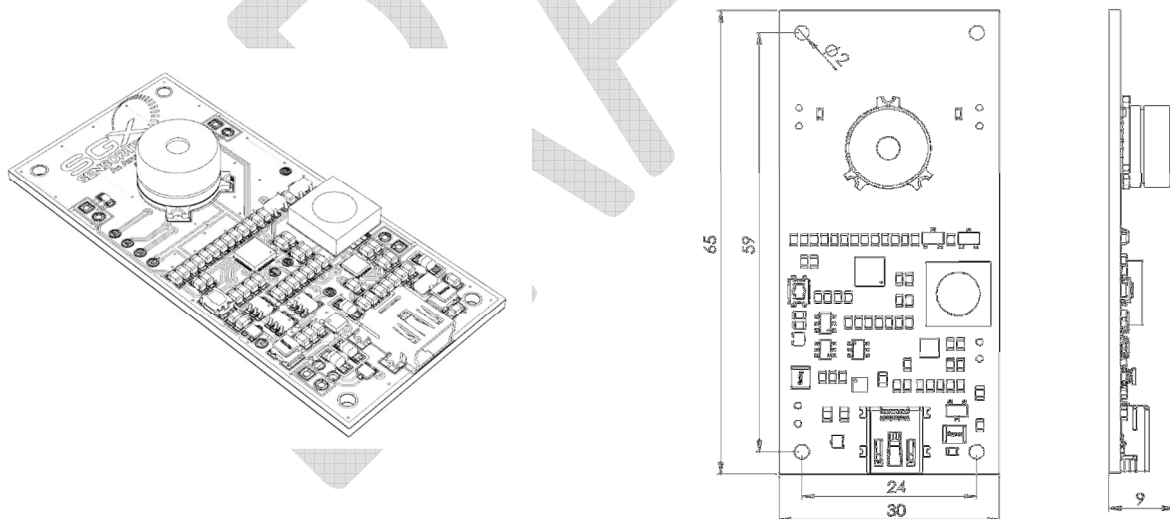

\*All dimensions are in millimeters unless stated otherwise.

**Special considerations**

The sensor is equipped with filters allowing it to operate in normal household environment. However sensor should not be subjected to high concentrations of agents containing silicon, sulfide and chlorine compounds (bleach, toilet cleaning agents, silicon greases). If longer exposition to any of the above the overall performance of the sensor might be affected causing limited response to gas.



Компания «ЭлектроПласт» предлагает заключение долгосрочных отношений при поставках импортных электронных компонентов на взаимовыгодных условиях!

Наши преимущества:

- Оперативные поставки широкого спектра электронных компонентов отечественного и импортного производства напрямую от производителей и с крупнейших мировых складов;
- Поставка более 17-ти миллионов наименований электронных компонентов;
- Поставка сложных, дефицитных, либо снятых с производства позиций;
- Оперативные сроки поставки под заказ (от 5 рабочих дней);
- Экспресс доставка в любую точку России;
- Техническая поддержка проекта, помощь в подборе аналогов, поставка прототипов;
- Система менеджмента качества сертифицирована по Международному стандарту ISO 9001;
- Лицензия ФСБ на осуществление работ с использованием сведений, составляющих государственную тайну;
- Поставка специализированных компонентов (Xilinx, Altera, Analog Devices, Intersil, Interpoint, Microsemi, Aeroflex, Peregrine, Syfer, Eurofarad, Texas Instrument, Miteq, Cobham, E2V, MA-COM, Hittite, Mini-Circuits, General Dynamics и др.);

Помимо этого, одним из направлений компании «ЭлектроПласт» является направление «Источники питания». Мы предлагаем Вам помощь Конструкторского отдела:

- Подбор оптимального решения, техническое обоснование при выборе компонента;
- Подбор аналогов;
- Консультации по применению компонента;
- Поставка образцов и прототипов;
- Техническая поддержка проекта;
- Защита от снятия компонента с производства.



#### Как с нами связаться

**Телефон:** 8 (812) 309 58 32 (многоканальный)

**Факс:** 8 (812) 320-02-42

**Электронная почта:** [org@eplast1.ru](mailto:org@eplast1.ru)

**Адрес:** 198099, г. Санкт-Петербург, ул. Калинина, дом 2, корпус 4, литера А.