

LT3496EUFD
Triple Boost or Buck-Boost
LED Driver

DESCRIPTION

WARNING!

Do not look directly at operating LED.
This circuit produces light that can damage eyes.

Demonstration circuit 1288 is a Triple Boost or Buck-Boost LED Driver featuring the LT3496EUFD. The LT3496 is a triple output DC/DC converter designed to operate as current sources for driving high current LEDs. For evaluating an LT3496 buck mode LED driver, use the demonstration circuit 986.

The board can be configured into either buck-boost (default) or boost mode. The current for each output is set at 200mA in either mode. The targeted input voltage PVIN range is 8V to 16V. The buck-boost circuit can tolerate an input voltage up to 40V when the LED string is on the high side. The part shuts down when the over-voltage threshold is reached. For a typical application with 5 LEDs totaling of 16V LED voltage, the circuit will operate until PVIN reaches 22V if the over-voltage protection is set to 38V. The buck-boost circuit with LEDs on the low side may not survive a 40V input transient. Applications with different input voltages and

load combinations can be demonstrated on this circuit with some board modifications. Call the LTC applications group for support.

Each of the three regulators on the demo board is independently operated. The PWM dimming feature of the LT3496 allows True Color PWM dimming with the dimming ratio of 5000:1. Additional analog dimming is possible.

Setting CTRL voltage to be less than 1V will set the current sense voltage to be one-tenth of CTRL voltage, therefore, reduce the LED current. The output current should not exceed the rated current of the LEDs used. The LED current thermal de-rating should be considered to protect the LEDs. Adjustable switching frequency allows optimization of the efficiency and the external component size.

The LT3496 datasheet gives complete description of the part, operation and application information. The datasheet must be read in conjunction with this quick start guide for working on or modifying the demo circuit 986.

Design files for this circuit board are available. Call the LTC factory.

 , LTC and LT are registered trademarks of Linear Technology Corporation.

PERFORMANCE SUMMARY Specifications are at TA = 25°C

SYMBOL	PARAMETER	CONDITIONS	MIN	TYP	MAX	UNITS
PVIN	Power Input Supply	Buck-Boost Mode (LEDs on High Side) Boost Mode	8 8		40 VLED*	V
VIN	Chip Bias Input Supply**		3		5.5	V
VOVP	Output Over-voltage Protection				38	V
ILED	Output LED Current, per Channel		188	196	204	mA
FSW	Switching Frequency	FADJ=VREF	1.9	2.1	2.3	MHz
η	Conversion Efficiency	Buck-Boost Mode: ILED = 200mA, PVIN=12V, VIN=3.3V, 5 LEDs Boost Mode: ILED = 200mA, PVIN=12V, VIN=3.3V, 7 LEDs		80		%
PWMD	PWM Dimming Ratio	PWM Frequency: 100Hz		5000:1		

* VLED is the forward voltage drop of a LED string

** VIN of the demo board is limited by the choice of the input capacitor. The LT3496 input range is 3V-30V with transient protection to 40V. A lower VIN helps to reduce the power dissipation in the chip.

MODE SETUP

	JP3, JP4, JP5	C2, C6, C8	C11, C12, C13	LED on High Side	LED on Low Side
Buck-Boost	=Buck-Boost	Not Install	Install	Short LEDnL+ and LEDnL-	Short LEDnH+ and LEDnH-
Boost	=Boost	Install	Not Install	N/A	Short LEDnH+ and LEDnH-

QUICK START PROCEDURE

Demonstration circuit 1288 is easy to set up to evaluate the performance of the LT3496EUFD. Refer to Figure 1 for proper measurement equipment setup and follow the procedure below:

1. With power off, select buck-boost or boost mode. Setup the board per the table in the "MODE SETUP" section. The default setting is for buck-boost mode.
2. Connect an input power supply to VIN and GND. To achieve highest efficiency, a low voltage supply, such as 3.3V or 5V, is recommended.
3. With power off, connect a second input power supply to PVIN and GND.
4. If an output channel *n* is not used, the PWM*n* should be tied to GND.
5. Turn on PVIN power supply.
6. Turn on VIN power supply.

7. Check for the proper LED current and LED string voltage.

NOTE. If there is no output, turn off the power supplies. Check all connections.

8. To observe PWM dimming, turn off all power supplies. Connect the PWMn to a pulse generator. Then repeat step 5 – 7.

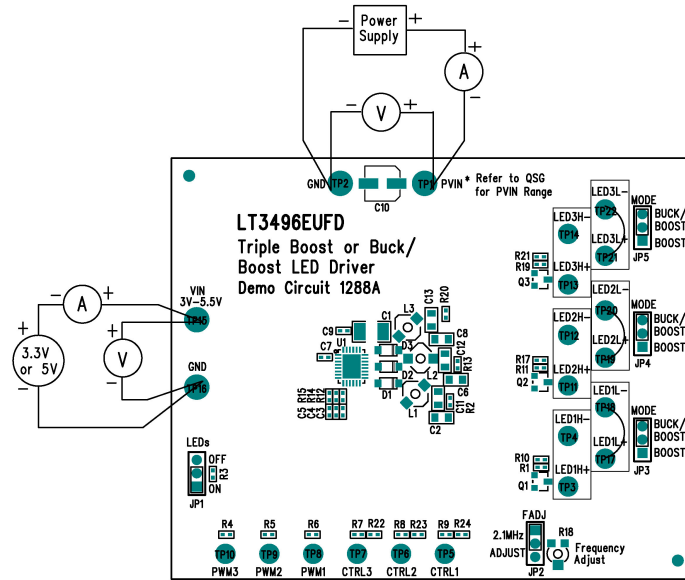

Figure 1. Proper Measurement Equipment Setup (LEDs on the High Side)

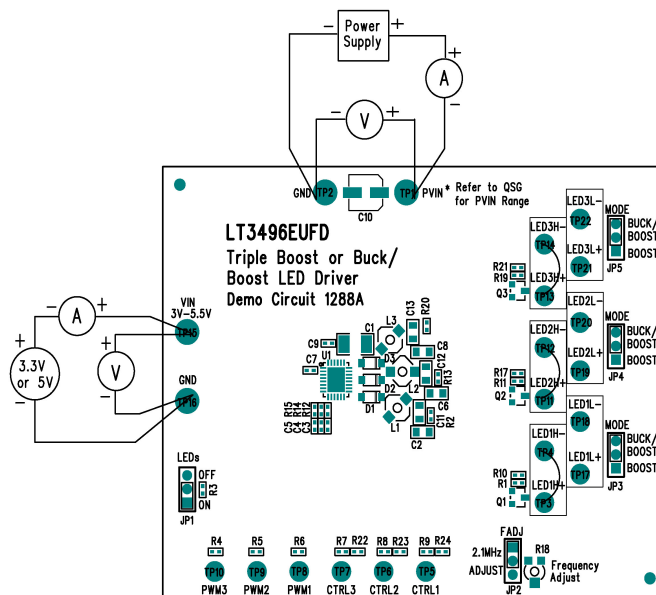
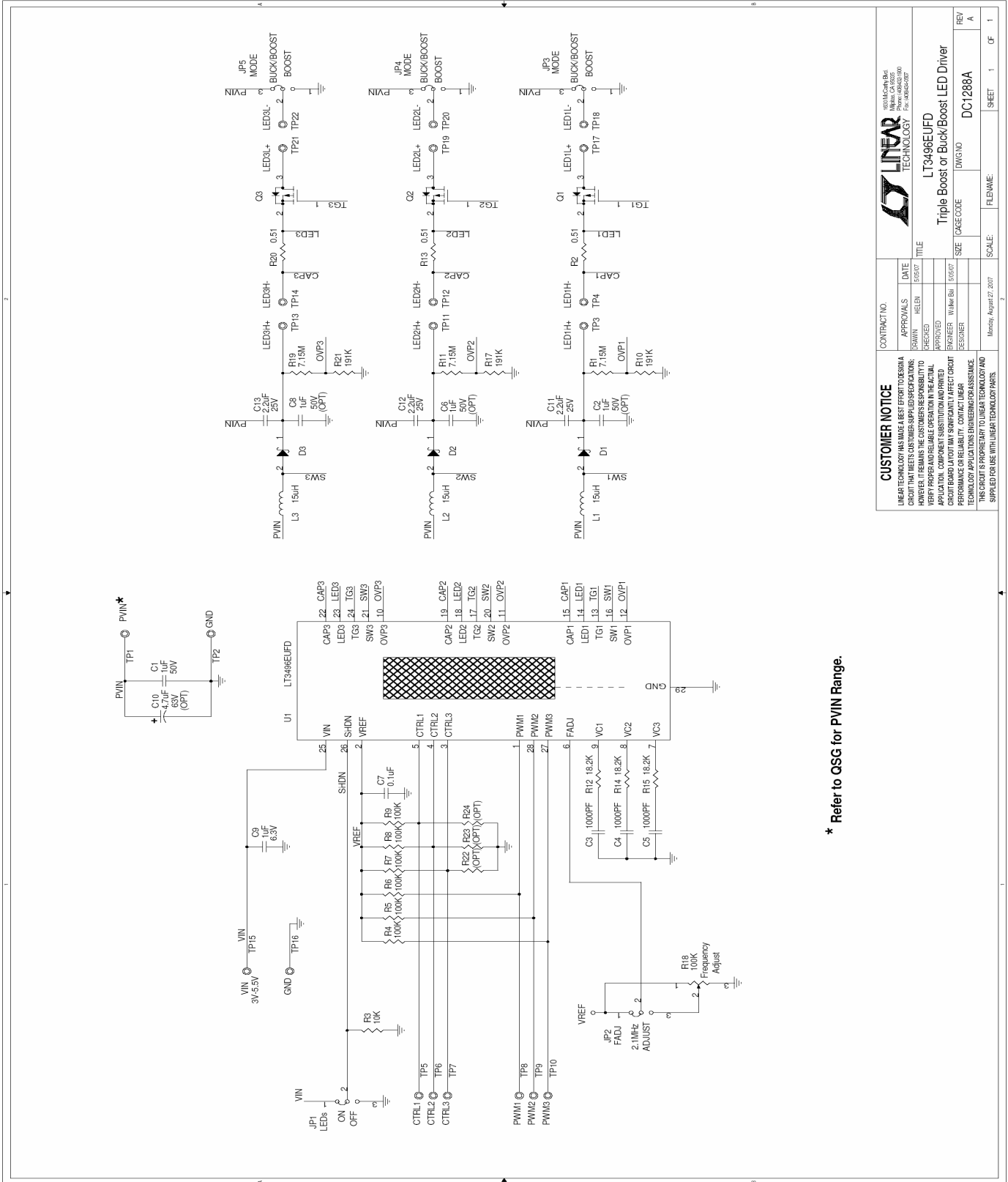

Figure 2. Proper Measurement Equipment Setup (LEDs on the Low Side)





Компания «ЭлектроПласт» предлагает заключение долгосрочных отношений при поставках импортных электронных компонентов на взаимовыгодных условиях!

Наши преимущества:

- Оперативные поставки широкого спектра электронных компонентов отечественного и импортного производства напрямую от производителей и с крупнейших мировых складов;
- Поставка более 17-ти миллионов наименований электронных компонентов;
- Поставка сложных, дефицитных, либо снятых с производства позиций;
- Оперативные сроки поставки под заказ (от 5 рабочих дней);
- Экспресс доставка в любую точку России;
- Техническая поддержка проекта, помощь в подборе аналогов, поставка прототипов;
- Система менеджмента качества сертифицирована по Международному стандарту ISO 9001;
- Лицензия ФСБ на осуществление работ с использованием сведений, составляющих государственную тайну;
- Поставка специализированных компонентов (Xilinx, Altera, Analog Devices, Intersil, Interpoint, Microsemi, Aeroflex, Peregrine, Syfer, Eurofarad, Texas Instrument, Miteq, Cobham, E2V, MA-COM, Hittite, Mini-Circuits, General Dynamics и др.);

Помимо этого, одним из направлений компании «ЭлектроПласт» является направление «Источники питания». Мы предлагаем Вам помощь Конструкторского отдела:

- Подбор оптимального решения, техническое обоснование при выборе компонента;
- Подбор аналогов;
- Консультации по применению компонента;
- Поставка образцов и прототипов;
- Техническая поддержка проекта;
- Защита от снятия компонента с производства.



Как с нами связаться

Телефон: 8 (812) 309 58 32 (многоканальный)

Факс: 8 (812) 320-02-42

Электронная почта: org@eplast1.ru

Адрес: 198099, г. Санкт-Петербург, ул. Калинина, дом 2, корпус 4, литера А.