



Product Specification	Model:	AWY-800480T70P04	Rev. No.	Issued Date.	Page.
			B	2016/01/06	1/22

Thin Film Transistor LCD MODULE
MODEL: AWY-800480T70P04
Customer's No.:

Acceptance

3504 Lake Lynda Drive, Suite110,
Orlando, FL., USA 32817

Approved and Checked by

Approved by	Checked by		Made by



<i>Product Specification</i>	<i>Model:</i>	AWY-800480T70P04	<i>Rev. No.</i>	<i>Issued Date.</i>	<i>Page.</i>
			B	2016/01/06	2/22

Revision Record

Rev No.	Rev Date	Contents	Note
A	2015/12/23	New issue.	
B	2016/01/06	Correction on general information values.	



Product Specification	Model:	AWY-800480T70P04	Rev. No.	Issued Date.	Page.
			B	2016/01/06	3/22

Table of Contents

List	Description	Page No.
	Cover	1
	Revision Record	2
	Table of Contents	3
1	Scope	4
2	General Information	4
3	External Dimensions	5
4	Interface Description	6
5	Absolute Maximum Ratings	7
6	DC Characteristics	7
7	Timing Characteristics	8
8	Backlight Characteristics	12
9	Optical Characteristics	13
10	Reliability Test Conditions and Methods	15
11	Inspection Standard	16
12	Handling Precautions	21
13	Precaution for Use	22



Product Specification	Model:	AWY-800480T70P04	Rev. No.	Issued Date.	Page.
			B	2016/01/06	4/22

1. Scope

This specification defines general provisions as well as inspection standards for TFT module supplied by ACROWISE electronics.

If the event of unforeseen problem or unspecified items may occur, naturally shall negotiate and agree to solution

2. General Information

LCM

Item	Standard Values	Units
LCD type	7.0" TFT	--
Dot arrangement	800x3(RGB)x480	dots
Color filter array	RGB vertical stripe	--
Display mode	TN / Transmissive / Normally white	--
Gray Scale Inversion Direction	6 o'clock	--
Viewing Direction	12 o'clock	
Module size	164.9(W)x100(H)x4.7(T)	mm
Active area	153.84(W)x85.63(H)	mm
Dot pitch	0.0641(W)x0.1784(H)	mm
Interface	24-bit Parallel RGB Interface	--
Operating temperature	-20 ~ +60	°C
Storage temperature	-30 ~ +70	°C
Back Light	24White LEDs	--
Weight	TBD	g

RTP

Item	Standard Values	Units
RTP type	Film + Glass + FPC Film: 0.188mm, Glass: 0.7mm	--
Surface hardness	3H(Pencil)	--
Transmittance	≥78%	--
RTP size	162.1 (W)x97.1 (H)x1.2(T)	mm
Active area	154.4(W)x88.8 (H)	mm
Operation Voltage	DC5V 1mA	
Insulation resistance	>20MΩ (25V DC)	MΩ
Response Time	≤10ms	ms
Linearity	X≤1.5%, Y≤1.5%	%
Hitting Life	≥1000000times	Times
Writing Life	≥100000(150g)times	Times
Operation force	50 ~ 120g	g
Operating temperature	-10 ~ +60	°C
Storage temperature	-20 ~ +70	°C
Resistance	X:200Ω ~ 900Ω Y:200Ω ~ 900Ω	Ω



Product Specification	Model:	AWY-800480T70P04	Rev. No.	Issued Date.	Page.
			B	2016/01/06	5/22

3. External Dimensions

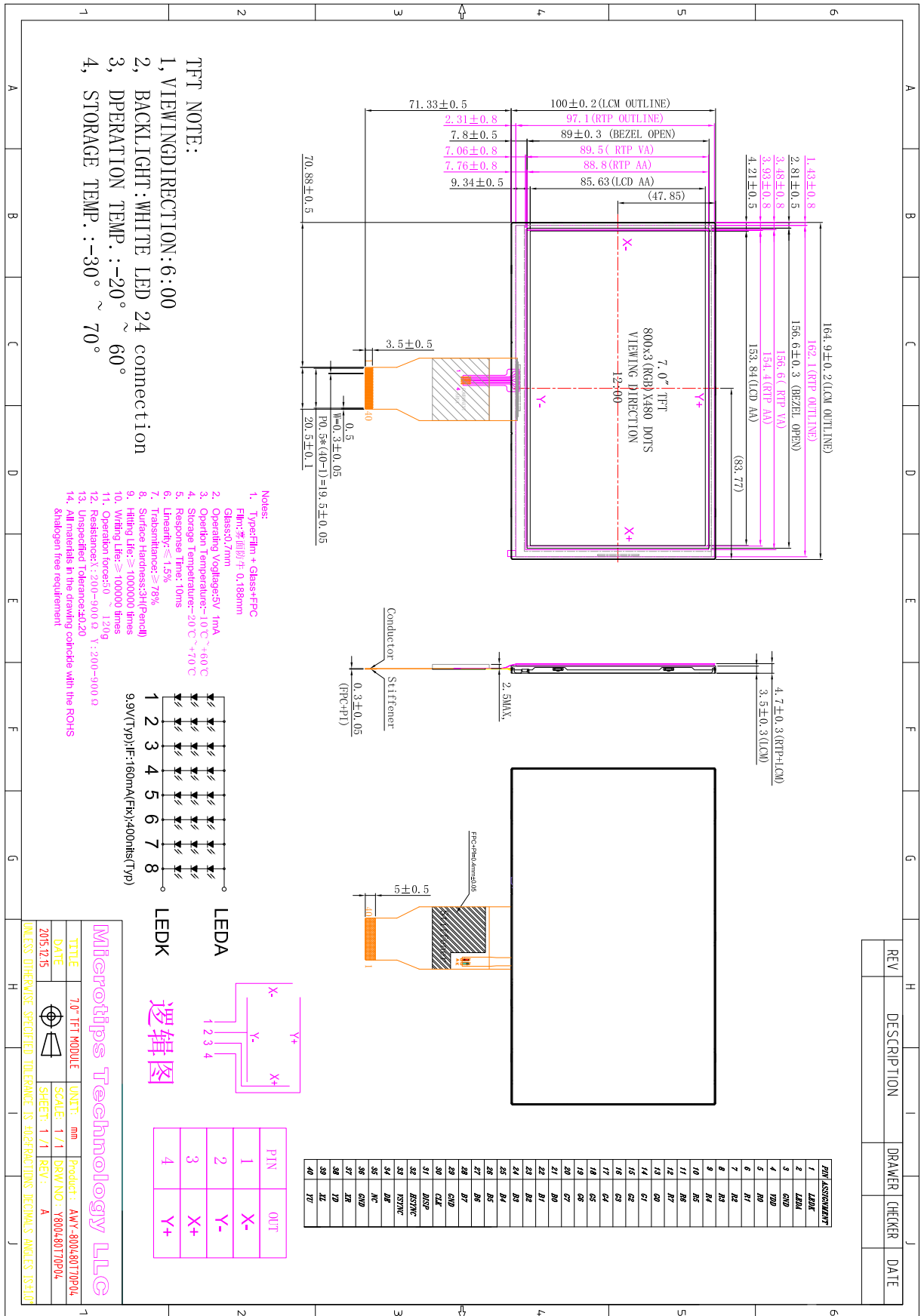



Product Specification	Model:	AWY-800480T70P04	Rev. No.	Issued Date.	Page.
			B	2016/01/06	6/22

4. Interface Description

Pin No.	Pin Name	Description
1	LED-K	LED backlight (Cathode).
2	LED-A	LED backlight (Anode).
3	GND	Ground.
4	VDD	Power supply.
5~12	R0~R7	Red Data
13~20	G0~G7	Green Data
21~28	B0~B7	Blue Data
29	GND	Ground.
30	DCLK	Clock
31	DISP	Display on/off
32	HSYNC	Horizontal sync input in RGB mode.
33	VSYNC	Vertical sync input in RGB mode.
34	DE	Data enable input. Active high to enable the input data bus.
35	NC	No connection.
36	GND	Ground.
37	XR	TP Right
38	YD	TP Bottom
39	XL	TP Left
40	YU	TP Up



Product Specification	Model:	AWY-800480T70P04	Rev. No.	Issued Date.	Page.
			B	2016/01/06	7/22

5. Absolute Maximum Ratings

Item	Symbol	Min.	Max.	Unit
Digital Supply Voltage	VDD	-0.5	5.0	V
Operating Temperature	TOP	-20	60	°C
Storage Temperature	TST	-30	70	°C
Storage Humidity	HD	20	90	%RH

6. DC Characteristics

Item	Symbol	Min.	Typ.	Max.	Unit	Remark
Digital Supply Voltage	VDD	2.5	3.3	3.6	V	-
Logic Input Voltage	VIH	0.7VDD	-	VDD	V	-
	VIL	GND	-	0.3VDD	V	-



Product Specification	Model:	AWY-800480T70P04	Rev. No.	Issued Date.	Page.
			B	2016/01/06	8/22

7. Timing Characteristics

7.1 Power Sequence

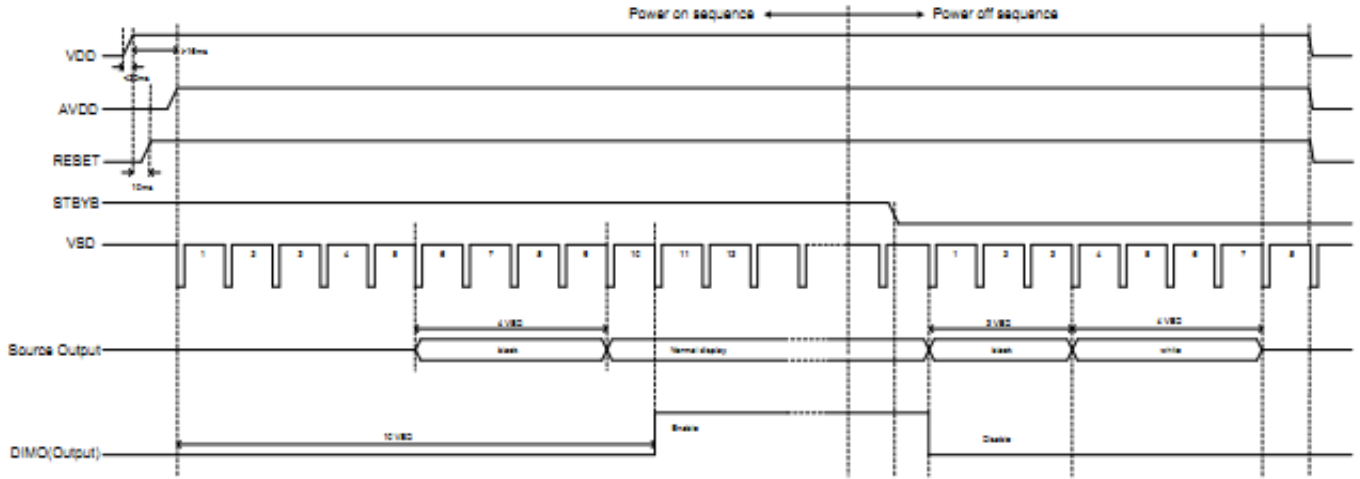

Power-On/Off Timing Sequence

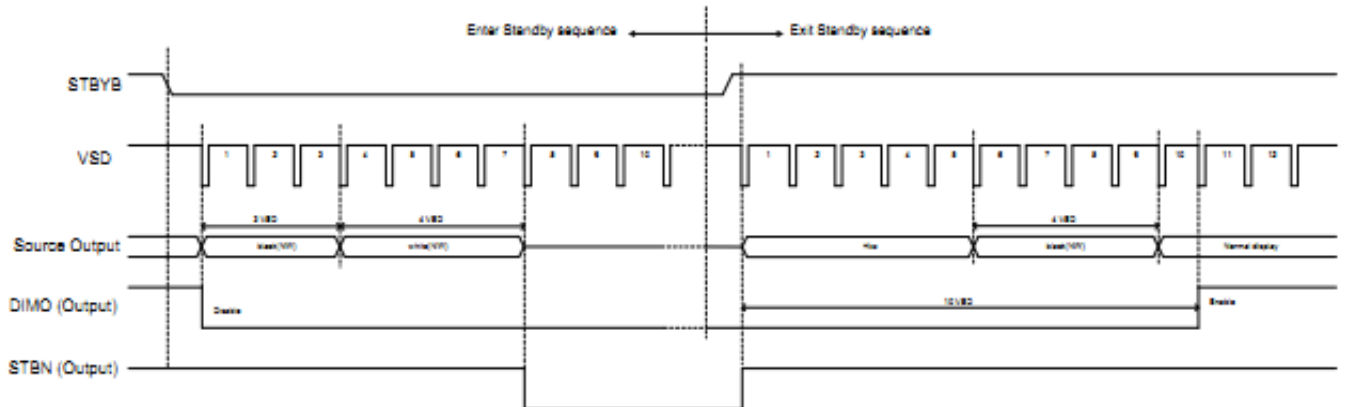

7.2 Data Input Format

Vertical input timing

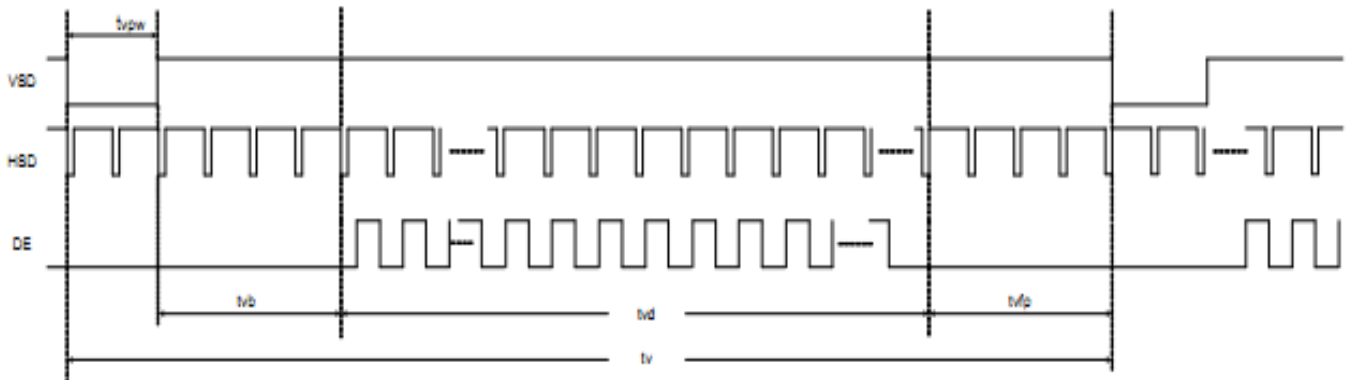



Product Specification	Model:	AWY-800480T70P04	Rev. No.	Issued Date.	Page.
			B	2016/01/06	9/22

Horizontal input timing

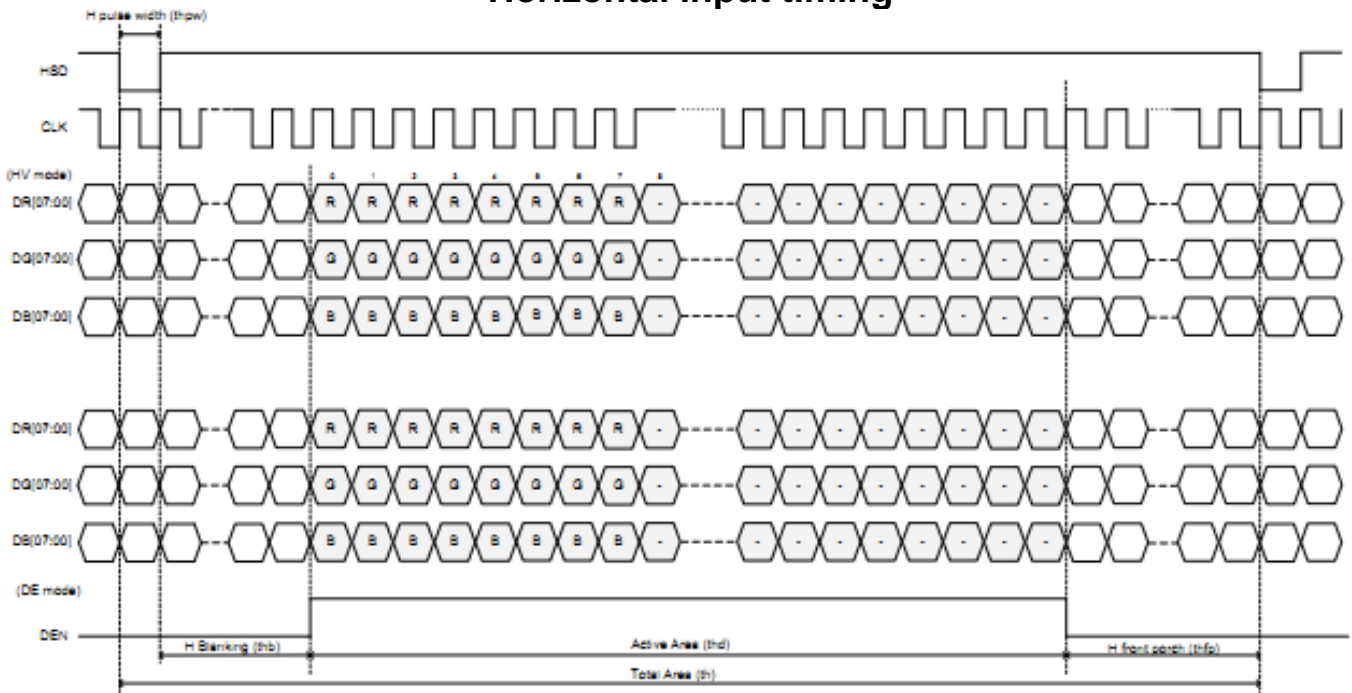

7.3 Timing

Horizontal input timing

Parameter	Symbol	Value			Unit	Note
Horizontal display area	thd	800			DCLK	
DCLK frequency	fclk	Min.	Typ.	Max	MHz	
		20	33.3	50		
1 Horizontal Line	th	908	928	1088	DCLK	thb+thpw=88 DCLK is fixed.
HSD pulse width	thpw	1	48	87		
HSD Back Porch (Blanking)	thb	87	40	1		
HSD Front Porch	thfp	20	40	200		

Vertical input timing

Parameter	Symbol	Min.	Typ.	Max.	Unit	Note
Vertical display area	tvd	480			H	
VSD period time	tv	517	525	712	H	tvpw+tvb=32H Is fixed
VSD pulse width	tvpw	1	1	3	H	
VSD Back Porch (Blanking)	tvb	31	31	29	H	
VSD Front Porch	tvfp	5	13	200	H	



Product Specification	Model:	AWY-800480T70P04	Rev. No.	Issued Date.	Page.
			B	2016/01/06	10/22

Timing Table(24-bit RGB Mode)

Parameter	Symbol	Condition	Min.	Typ.	Max.	Unit
CLKIN Frequency	Fclk	VDD = 2.5V ~3.6V	-	33.3	50	MHz
CLKIN Cycle Time	Tclk	-	20	25	-	ns
CLKIN Pulse Duty	Tcwh	Tclk	40	50	60	%
Time from HSD to Source Output	Thso		-	46	-	CLKIN
Time from HSD to LD	Thld		-	46	-	CLKIN
Time from HSD to STV	Thstv	-	-	2	-	CLKIN
Time from HSD to CKV	Thckv	-	-	20	-	CLKIN
Time from HSD to OEV	Thoev	-	-	4	-	CLKIN
LD Pulse Width	Twld			10		CLKIN
CKV Pulse Width	Twckv	-	-	66	-	CLKIN
OEV Pulse Width	Twoev	-	-	74	-	CLKIN

7.4 Timing Waveform

Input clock and data timing diagram

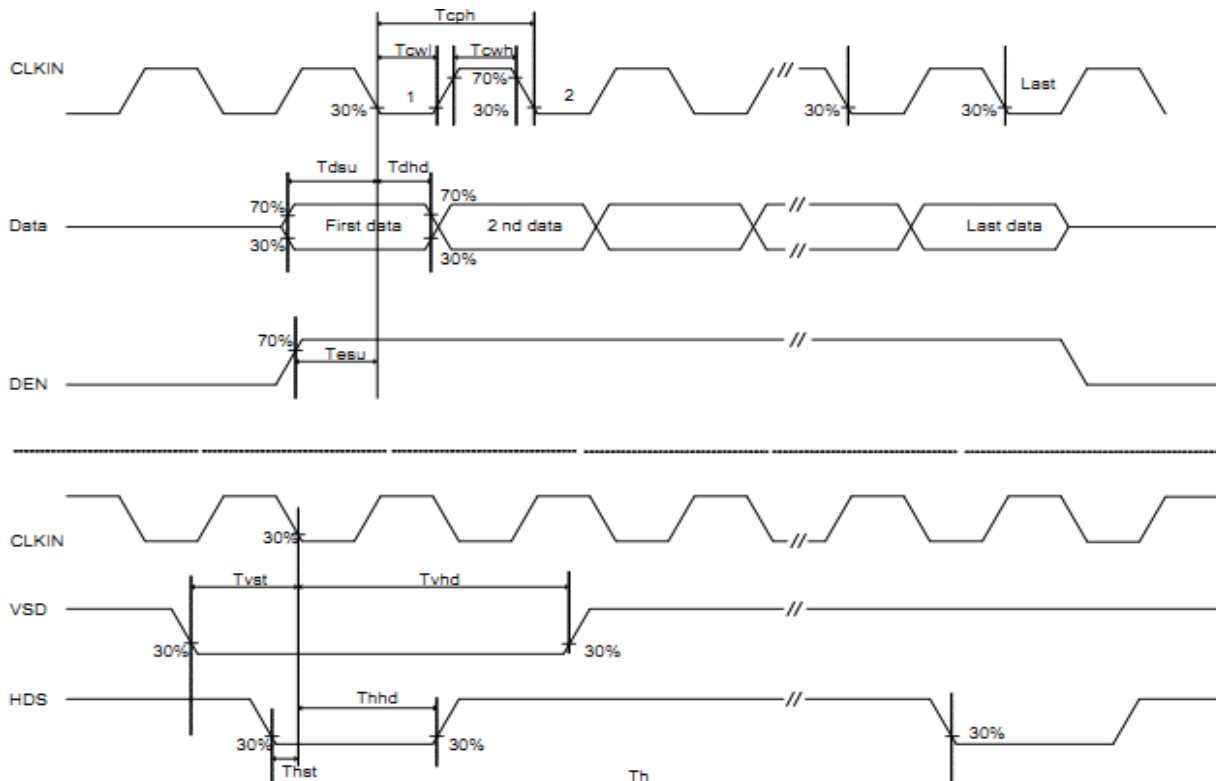

Output load condition

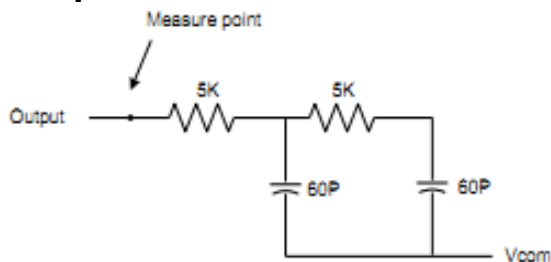



Product Specification	Model:	AWY-800480T70P04	Rev. No.	Issued Date.	Page.
			B	2016/01/06	11/22

Vertical timing diagram HV (Dual Gate)

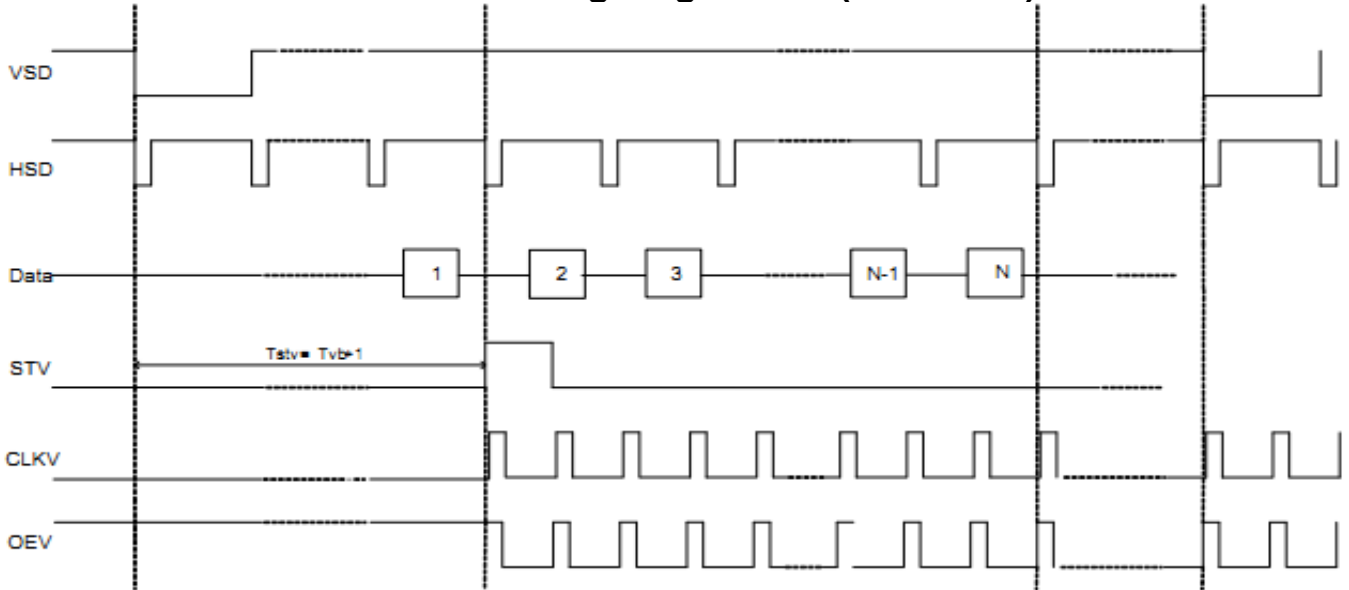

Vertical timing diagram DE (Dual Gate)

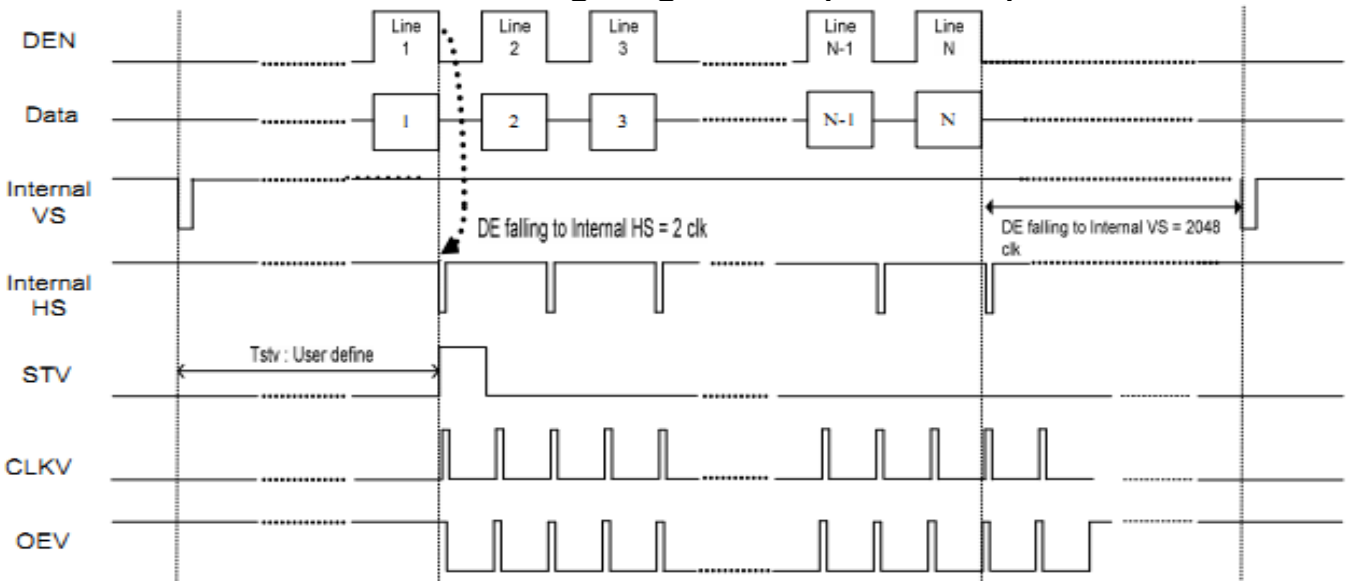

Gate output timing diagram (Dual Gate)

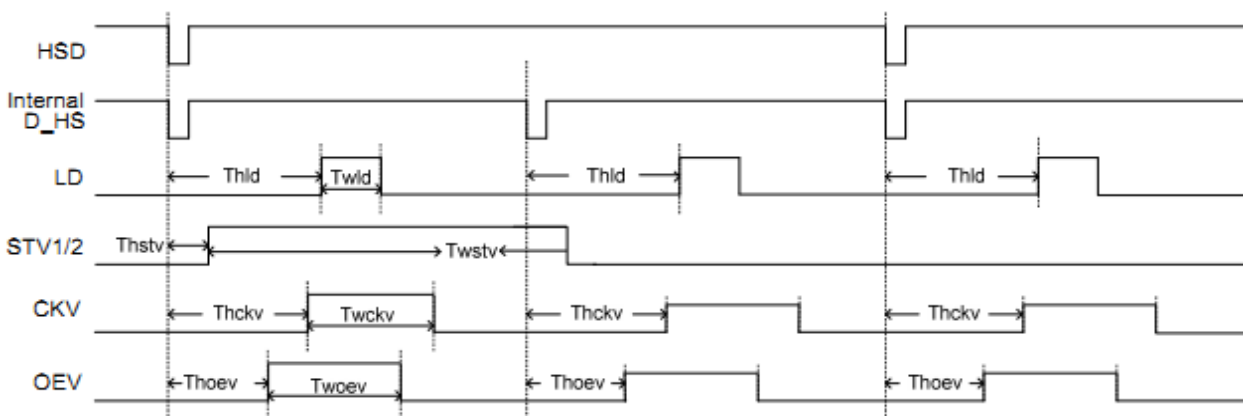



Product Specification	Model:	AWY-800480T70P04	Rev. No.	Issued Date.	Page.
			B	2016/01/06	12/22

8. Backlight Characteristic

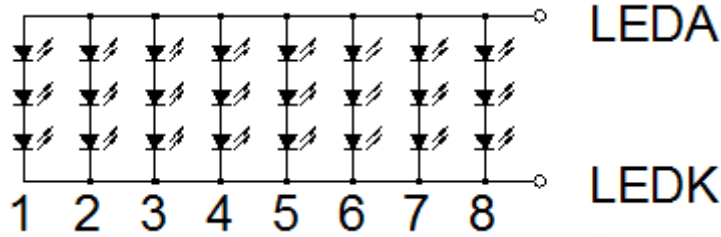

Item	Symbol	MIN	TYP	MAX	UNIT	Test Condition
Supply Voltage	Vf	8.7	9.9	10.5	V	If=160mA
Supply Current	If	-	160	-	mA	-
Luminous Intensity for LCM	-	350	400	-	cd/m ²	If=160mA
Uniformity for LCM	-	80	-	-	%	If=160mA
Life Time	-	20000	(30000)	-	Hr	If=160mA
Backlight Color	White					



Product Specification	Model:	AWY-800480T70P04	Rev. No.	Issued Date.	Page.
			B	2016/01/06	13/22

9. Optical Characteristics

Item	Conditions	Min.	Typ.	Max.	Unit	Note	
Viewing Angle (CR>10)	Horizontal	θ_L	60	70	-	degree	(1),(2),(6)
		θ_R	60	70	-		
	Vertical	θ_T	60	70	-		
		θ_B	50	60	-		
Contrast Ratio	Center	350	500	-	-	(1),(3),(6)	
Response Time	Rising	-	25	-	ms	(1),(4),(6)	
	Falling						
CF Color Chromaticity (CIE1931)	Red x	Typ. -0.05	TBD	Typ. +0.05	-	(1), (6)	
	Red y		TBD		-		
	Green x		TBD		-		
	Green y		TBD		-		
	Blue x		TBD		-		
	Blue y		TBD		-		
	White x		TBD		-		
	White y		TBD		-		

Note (1) Measurement Setup: The LCD module should be stabilized at given temp. 25°C for 15 minutes to avoid abrupt temperature change during measuring. In order to stabilize the luminance, the measurement should be executed after lighting backlight for 15 minutes in a windless room.

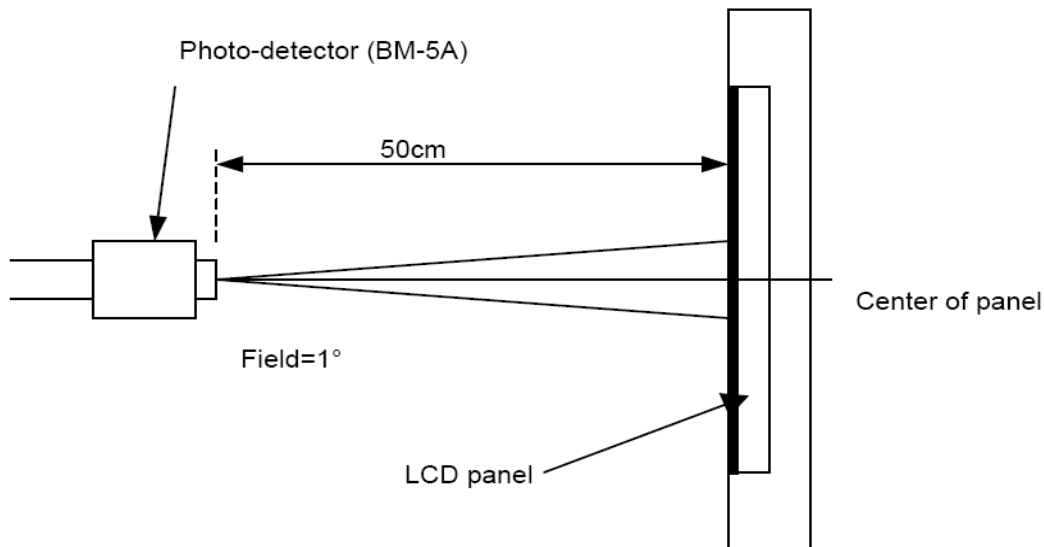



Product Specification	Model:	AWY-800480T70P04	Rev. No.	Issued Date.	Page.
			B	2016/01/06	14/22

Note (2) Definition of Viewing Angle

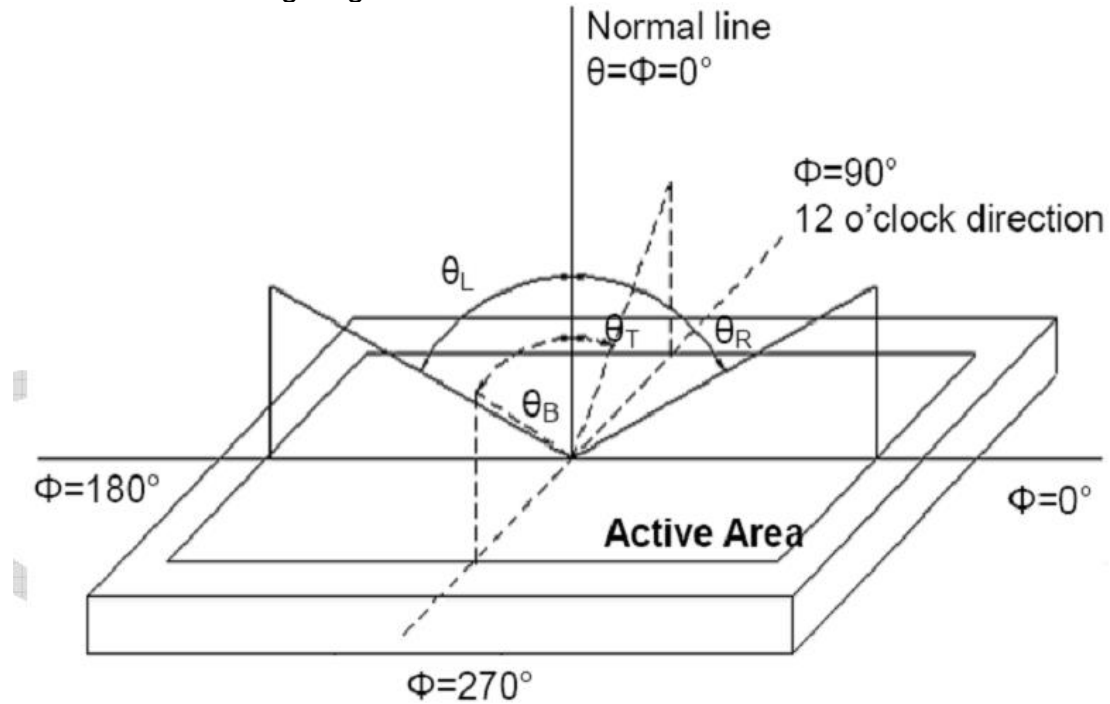

Note (3) Definition of Contrast Ratio (CR)

The contrast ratio can be calculated by the following expression

$$\text{Contrast Ratio (CR)} = L_{63} / L_0$$

L63: Luminance of gray level 63, L0: Luminance of gray level 0

Note (4) Definition of response time

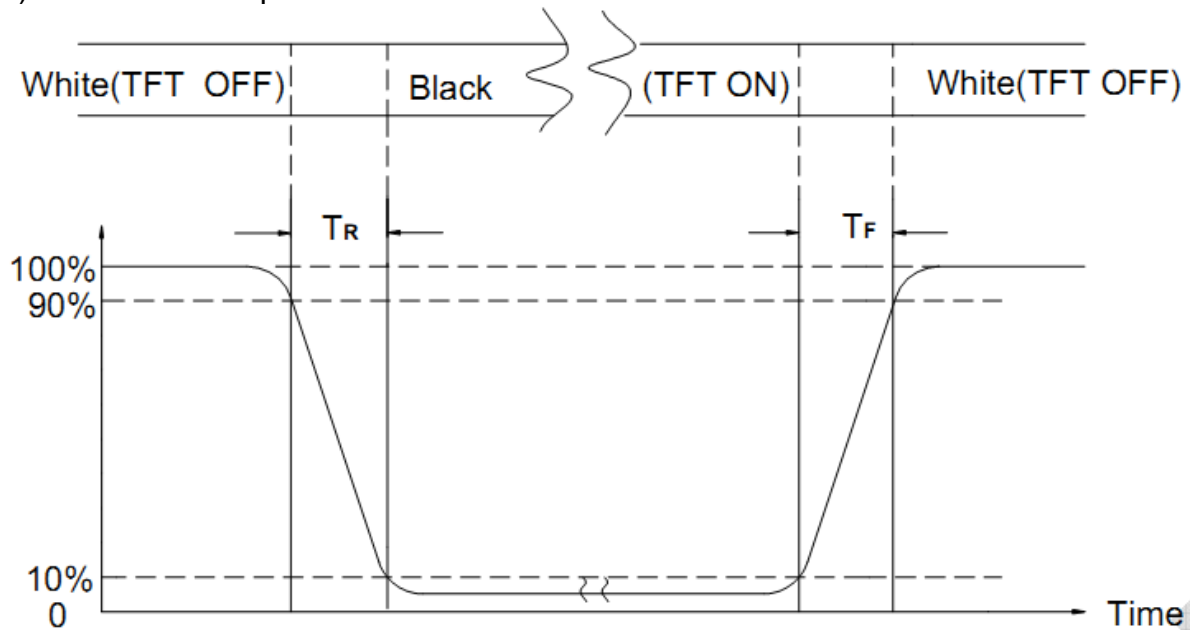

Note (5) Definition of Transmittance (Module is without signal input)

$$\text{Transmittance} = \text{Center Luminance of LCD} / \text{Center Luminance of Back Light} \times 100\%$$

Note (6) Definition of color chromaticity (CIE1931)

Color coordinates measured at the center point of LCD



Product Specification	Model:	AWY-800480T70P04	Rev. No.	Issued Date.	Page.
			B	2016/01/06	15/22

10. Reliability Test Conditions and Methods

No.	Test Items	Test Condition											
①	High Temperature Storage	Keep in 70°C ±5°C 96 hrs Surrounding temperature, then storage at normal condition 4hrs.											
②	Low Temperature Storage	Keep in -30°C ±5°C 96 hrs Surrounding temperature, then storage at normal condition 4hrs.											
③	High Temperature / High Humidity Storage Test	Keep in 50°C / 90% R.H duration for 96 hrs Surrounding temperature, then storage at normal condition 4hrs. (Excluding the polarizer)											
④	Temperature Cycling Storage Test	$ \begin{array}{ccccccc} & -20^{\circ}\text{C} & \rightarrow & +25^{\circ}\text{C} & \rightarrow & 60^{\circ}\text{C} & \rightarrow & +25^{\circ}\text{C} \\ & (30\text{mins}) & & (5\text{mins}) & & (30\text{mins}) & & (5\text{mins}) \\ & \longleftarrow & & \text{10 Cycle} & & \longrightarrow & & \\ \end{array} $ Surrounding temperature, then storage at normal condition 4hrs.											
⑤	ESD Test	Air Discharge: Apply 2 KV with 5 times Discharge for each polarity +/-	Contact Discharge: Apply 250 V with 5 times discharge for each polarity +/-										
		1. Temperature ambience : 15°C ~ 35°C 2. Humidity relative : 30% ~ 60% 3. Energy Storage Capacitance(Cs + Cd) : 150pF±10% 4. Discharge Resistance(Rd) : 330Ω±10% 5. Discharge, mode of operation : Single Discharge (time between successive discharges at least 1 sec) (Tolerance if the output voltage indication : ±5%)											
⑥	Vibration Test (Packaged)	1. Sine wave 10~55 Hz frequency (1 min/sweep) 2. The amplitude of vibration :1.5 mm 3. Each direction (X、 Y、 Z) duration for 2 Hrs											
⑦	Drop Test (Packaged)	<table border="1" style="margin-left: auto; margin-right: auto;"> <thead> <tr> <th>Packing Weight (Kg)</th> <th>Drop Height (cm)</th> </tr> </thead> <tbody> <tr> <td>0 ~ 45.4</td> <td>122</td> </tr> <tr> <td>45.4 ~ 90.8</td> <td>76</td> </tr> <tr> <td>90.8 ~ 454</td> <td>61</td> </tr> <tr> <td>Over 454</td> <td>46</td> </tr> </tbody> </table> Drop Direction :※1 corner / 3 edges / 6 sides each 1time		Packing Weight (Kg)	Drop Height (cm)	0 ~ 45.4	122	45.4 ~ 90.8	76	90.8 ~ 454	61	Over 454	46
Packing Weight (Kg)	Drop Height (cm)												
0 ~ 45.4	122												
45.4 ~ 90.8	76												
90.8 ~ 454	61												
Over 454	46												



Product Specification	Model:	AWY-800480T70P04	Rev. No.	Issued Date.	Page.
			B	2016/01/06	16/22

11. Inspection Standard

11.1. QUALITY :

THE QUALITY OF GOODS SUPPLIED TO PURCHASER SHALL COME UP TO THE FOLLOWING STANDARD.

11.1.1. THE METHOD OF PRESERVING GOODS

AFTER DELIVERY OF GOODS FROM AMSON TO PURCHASER. PURCHASER SHALL CONTROL THE LCM AT -10 °C TO 40°C ,AND IT MIGHT BE DESIRABLE TO KEEP AT THE NORMAL ROOM TEMPERATURE AND HUMIDITY UNTIL INCOMING INSPECTION OR THROWING INTO PROCESS LINE.

11.1.2. INCOMING INSPECTION

(A) THE METHOD OF INSPECTION

IF PURCHASER MAKE AN INCOMING INSPECTION , A SAMPLING PLAN SHALL BE APPLIED ON THE CONDITION THAT QUALITY OF ONE DELIVERY SHALL BE REGARDED AS ONE LOT.

(B) THE STANDARD OF QUALITY

ISO-2859-1 (SAME AS MIL-STD-105E) , LEVEL II SINGLE PLAN.

CLASS	AQL(%)
CRITICAL	0.4 %
MAJOR	0.65 %
MINOR	1.5 %
TOTAL	1.5 %

EVERY ITEM SHALL BE INSPECTED ACCORDING TO THE CLASS.

(C) MEASURE

IF AS THE RESULT OF ABOVE RECEIVING INSPECTION , A LOT OUT IS DISCOVERED. PURCHASER SHALL BE INFORM SELLER OF IT WITHIN SEVEN DAYS. BUT FIRST SHIPMENT WITHIN FOURTEEN DAYS.

11.1.3. WARRANTY POLICY

AMSON WILL PROVIDE ONE-YEAR WARRANTY FOR THE PRODUCTS ONLY IF UNDER SPECIFICATION OPERATING CONDITIONS. AMSON WILL REPLACE NEW PRODUCTS FOR THESE DEFECT PRODUCTS WHICH UNDER WARRANTY PERIOD AND BELONG TO THE RESPONSIBILITY OF AMSON.

11.2. CHECKING CONDITION

11.2.1. CHECKING DIRECTION SHALL BE IN THE 45 DEGREE AREA TO FACE THE SAMPLE.

11.2.2. CHECKER SHALL SEE OVER 300±25 mm. WITH BARE EYES FAR FROM SAMPLE AND USING 2 PCS. OF 20W FLUORESCENT LAMP.



Product Specification	Model:	AWY-800480T70P04	Rev. No.	Issued Date.	Page.
			B	2016/01/06	17/22

11.3. INSPECTION PLAN :

CLASS	ITEM	JUDGEMENT	CLASS
PACKING & INDICATE	1. OUTSIDE AND INSIDE PACKAGE	"MODEL NO." , "LOT NO." AND "QUANTITY" SHOULD INDICATE ON THE PACKAGE.	Minor
	2. MODEL MIXED AND QUANTITY	OTHER MODEL MIXED.....REJECTED QUANTITY SHORT OR OVER.....REJECTED	Critical
	3. PRODUCT INDICATION	"MODEL NO." SHOULD INDICATE ON THE PRODUCT	Major
ASSEMBLY	4. DIMENSION, LCD GLASS SCRATCH AND SCRIBE DEFECT.	ACCORDING TO SPECIFICATION OR DRAWING.	Major
APPEARANCE	5. VIEWING AREA	POLARIZER EDGE OR LCD'S SEALING LINE IS VISABLE IN THE VIEWING AREAREJECTED	Minor
	6. BLEMISH · BLACK SPOT · WHITE SPOT IN THE LCD AND LCD GLASS CRACKS	ACCORDING TO STANDARD OF VISUAL INSPECTION(INSIDE VIEWING AREA)	Minor
	7. BLEMISH · BLACK SPOT WHITE SPOT AND SCRATCH ON THE POLARIZER	ACCORDING TO STANDARD OF VISUAL INSPECTION(INSIDE VIEWING AREA)	Minor
	8. BUBBLE IN POLARIZER	ACCORDING TO STANDARD OF VISUAL INSPECTION(INSIDE VIEWING AREA)	Minor
	9. LCD'S RAINBOW COLOR	STRONG DEVIATION COLOR (OR NEWTON RING) OF LCD.....REJECTED. OR ACCORDING TO LIMITED SAMPLE (IF NEEDED, AND INSIDE VIEWING AREA)	Minor
ELECTRICAL	10. ELECTRICAL AND OPTICAL CHARACTERISTICS (CONTRAST· VOP · CHROMATICITY ... ETC)	ACCORDING TO SPECIFICATION OR DRAWING . (INSIDE VIEWING AREA)	Critical
	11.MISSING LINE	MISSING DOT · LINE · CHARACTERREJECTED	Critical
	12.SHORT CIRCUIT· WRONG PATTERN DISPLAY	NO DISPLAY · WRONG PATTERN DISPLAY · CURRENT CONSUMPTION OUT OF SPECIFICATION..... REJECTED	Critical
	13. DOT DEFECT (FOR COLOR AND TFT)	ACCORDING TO STANDARD OF VISUAL INSPECTION	Minor



Product Specification	Model:	AWY-800480T70P04	Rev. No.	Issued Date.	Page.
			B	2016/01/06	18/22

11.4. STANDARD OF VISUAL INSPECTION

NO.	CLASS	ITEM	JUDGEMENT																				
11.4.1	MINOR	BLACK AND WHITE SPOT FOREIGN MATERIEL DUST IN THE CELL BLEMISH SCRATCH	<p>(A) ROUND TYPE: unit : mm.</p> <table border="1"> <thead> <tr> <th>DIAMETER (mm.)</th> <th>ACCEPTABLE Q'TY</th> </tr> </thead> <tbody> <tr> <td>$\Phi \leq 0.2$</td> <td>DISREGARD</td> </tr> <tr> <td>$0.2 < \Phi \leq 0.4$</td> <td>3 (Distance>5mm)</td> </tr> <tr> <td>$0.4 < \Phi$</td> <td>0</td> </tr> </tbody> </table> <p>NOTE: $\Phi = (\text{LENGTH} + \text{WIDTH}) / 2$</p> <p>(B) LINEAR TYPE: unit : mm.</p> <table border="1"> <thead> <tr> <th>LENGTH</th> <th>WIDTH</th> <th>ACCEPTABLE Q'TY</th> </tr> </thead> <tbody> <tr> <td>-----</td> <td>$W \leq 0.05$</td> <td>DISREGARD</td> </tr> <tr> <td>$L \leq 5.0$</td> <td>$0.05 < W \leq 0.08$</td> <td>3 (Distance>5mm)</td> </tr> <tr> <td>-----</td> <td>$0.08 < W$</td> <td>FOLLOW ROUND TYPE</td> </tr> </tbody> </table>	DIAMETER (mm.)	ACCEPTABLE Q'TY	$\Phi \leq 0.2$	DISREGARD	$0.2 < \Phi \leq 0.4$	3 (Distance>5mm)	$0.4 < \Phi$	0	LENGTH	WIDTH	ACCEPTABLE Q'TY	-----	$W \leq 0.05$	DISREGARD	$L \leq 5.0$	$0.05 < W \leq 0.08$	3 (Distance>5mm)	-----	$0.08 < W$	FOLLOW ROUND TYPE
DIAMETER (mm.)	ACCEPTABLE Q'TY																						
$\Phi \leq 0.2$	DISREGARD																						
$0.2 < \Phi \leq 0.4$	3 (Distance>5mm)																						
$0.4 < \Phi$	0																						
LENGTH	WIDTH	ACCEPTABLE Q'TY																					
-----	$W \leq 0.05$	DISREGARD																					
$L \leq 5.0$	$0.05 < W \leq 0.08$	3 (Distance>5mm)																					
-----	$0.08 < W$	FOLLOW ROUND TYPE																					
11.4.2	MINOR	BUBBLE IN POLARIZER DENT ON POLARIZER	<p style="text-align: right;">unit : mm.</p> <table border="1"> <thead> <tr> <th>DIAMETER</th> <th>ACCEPTABLE Q'TY</th> </tr> </thead> <tbody> <tr> <td>$\Phi \leq 0.3$</td> <td>DISREGARD</td> </tr> <tr> <td>$0.3 < \Phi \leq 0.6$</td> <td>3 (Distance>7mm)</td> </tr> <tr> <td>$0.6 < \Phi$</td> <td>0</td> </tr> </tbody> </table>	DIAMETER	ACCEPTABLE Q'TY	$\Phi \leq 0.3$	DISREGARD	$0.3 < \Phi \leq 0.6$	3 (Distance>7mm)	$0.6 < \Phi$	0												
DIAMETER	ACCEPTABLE Q'TY																						
$\Phi \leq 0.3$	DISREGARD																						
$0.3 < \Phi \leq 0.6$	3 (Distance>7mm)																						
$0.6 < \Phi$	0																						
11.4.3	MINOR	Dot Defect	<table border="1"> <thead> <tr> <th>Items</th> <th>ACC. Q'TY</th> </tr> </thead> <tbody> <tr> <td>Bright dot</td> <td>$N \leq 5$</td> </tr> <tr> <td>Dark dot</td> <td>$N \leq 5$</td> </tr> </tbody> </table> <p>Pixel Define :</p> <p>Note 1: The definition of dot: The size of a defective dot over 1/2 of whole dot is regarded as one defective dot.</p> <p>Note 2: Bright dot: Dots appear bright and unchanged in size in which LCD panel is displaying under black pattern.</p> <p>Note 3: Dark dot: Dots appear dark and unchanged in size in which LCD panel is displaying under pure red, green, blue pattern.</p>	Items	ACC. Q'TY	Bright dot	$N \leq 5$	Dark dot	$N \leq 5$														
Items	ACC. Q'TY																						
Bright dot	$N \leq 5$																						
Dark dot	$N \leq 5$																						

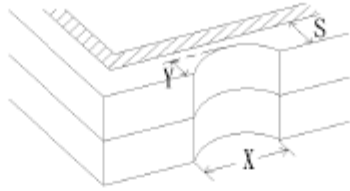
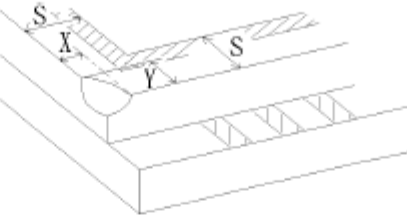
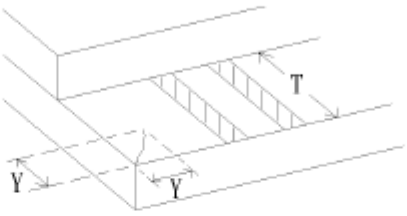
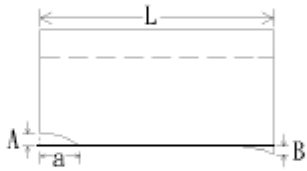
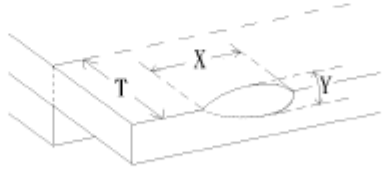
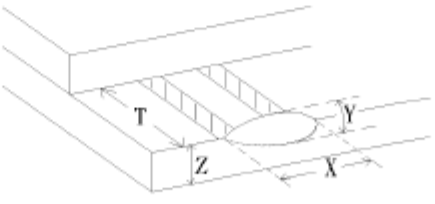
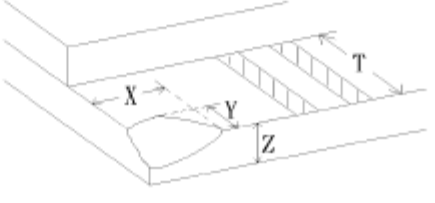

Product Specification	Model:	AWY-800480T70P04	Rev. No.	Issued Date.	Page.
			B	2016/01/06	19/22

NO.	CLASS	ITEM	JUDGEMENT
11.4.4	MINOR	LCD GLASS CHIPPING	 $Y > S$ Reject
11.4.5	MINOR	LCD GLASS CHIPPING	 $X \text{ or } Y > S$ Reject
11.4.6	MAJOR	LCD GLASS GLASS CRACK	 $Y > (1/2) T$ Reject
11.4.7	MAJOR	LCD GLASS SCRIBE DEFECT	 <ol style="list-style-type: none"> $a > L/3$, $A > 1.5\text{mm}$. Reject B : ACCORDING TO DIMENSION
11.4.8	MINOR	LCD GLASS CHIPPING (ON THE TERMINAL AREA)	 $\Phi = (x+y)/2 > 2.5 \text{ mm}$ Reject
11.4.9	MINOR	LCD GLASS CHIPPING (ON THE TERMINAL SURFACE)	 $Y > (1/3) T$ Reject
11.4.10	MINOR	LCD GLASS CHIPPING	 $Y > T$ Reject



Product Specification	Model:	AWY-800480T70P04	Rev. No.	Issued Date.	Page.
			B	2016/01/06	20/22

11.5 INSPECTION STANDARD OF TOUCH PANEL

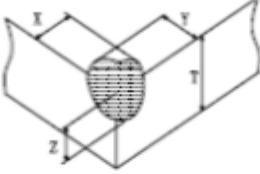
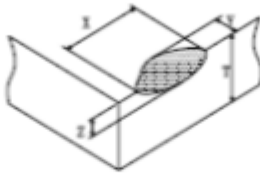
NO.	CLASS	ITEMS		JUDGEMENT
11.5.1	MAJOR	Touch Panel Crack		 Reject
11.5.2	MINOR	Touch Panel Chipping	Corner	 $X \leq 2\text{mm}, Y \leq 2\text{mm}, Z < 1/2T$ Accept
			Edge	 $X \leq 3\text{mm}, Y \leq 3\text{mm}, Z < 1/2T$ Accept
11.5.3	MINOR	Scratch Dust and Foreign materiel (Linear Type)		$W \leq 0.05, L \leq 20\text{mm}$ Accept
				$0.05\text{mm} < W \leq 0.08\text{mm}; L \leq 10.0\text{mm}$ Distance between seratch $> 5.0\text{mm}$ Accept 3 ea Max.
				$W > 0.08\text{mm}$ Reject
11.5.4	MINOR	Scratch Dust and Foreign materiel (Round Type: $\Phi = (\text{Length} + \text{Width})/2$)		$\Phi \leq 0.3 \text{ mm}$ Accept
				$0.3 \text{ mm} < \Phi \leq 0.6 \text{ mm}$ Distance between spots $> 5.0\text{mm}$ Accept 5 ea Max.
				$\Phi > 0.55\text{mm}$ Reject
11.5.5	MINOR	Touch Panel Dent / Fish Eyes		$\Phi \leq 0.55\text{mm}$ Accept
				$0.35\text{mm} < \Phi \leq 1.0\text{mm}$ Distance $> 5.0\text{mm}$ Accept 3 ea Max.
				$\Phi > 2.0\text{mm}$ Reject
11.5.6	MINOR	Touch Panel Air Bubble		$\Phi \leq 0.2\text{mm}$ Accept
				$0.3 \text{ mm} < \Phi \leq 0.6\text{mm}$ Distance between bubbles $> 5.0\text{mm}$ Accept 3 ea Max.
				$\Phi > 0.5\text{mm}$ Reject
11.5.7	MINOR	Touch Panel Printing area Scratch		$W \leq 0.05\text{mm}, L \leq 5\text{mm}$ Distance between scratch $> 5.0\text{mm}$ Accept 3 ea Max.
				$W > 0.05\text{mm}$ or $L > 5\text{mm}$ ($W > 0.05$ Follow 11.5.4 Round type) Reject
11.5.8	MINOR	Touch Panel White Haze Mark / Dust		Can not be removed Reject



Product Specification	Model:	AWY-800480T70P04	Rev. No.	Issued Date.	Page.
			B	2016/01/06	21/22

12. Handling Precautions

12.1 Mounting method

The LCD panel of ACROWISE TFT module consists of two thin glass plates with polarizers which easily be damaged. And since the module is so constructed as to be fixed by utilizing fitting holes in the printed circuit board.

Extreme care should be needed when handling the LCD modules.

12.2 Caution of LCD handling and cleaning

When cleaning the display surface, Use soft cloth with solvent [Recommended below] and wipe lightly

- Isopropyl alcohol
- Ethyl alcohol

Do not wipe the display surface with dry or hard materials that will damage the polarizer surface.

Do not use the following solvent:

- Water
- Aromatics

Do not wipe ITO pad area with the dry or hard materials that will damage the ITO patterns

Do not use the following solvent on the pad or prevent it from being contaminated:

- Soldering flux
- Chlorine (Cl) , Sulfur (S)

If goods were sent without being silicon coated on the pad, ITO patterns could be damaged due to the corrosion as time goes on.

If ITO corrosion happens by miss-handling or using some materials such as Chlorine (Cl), Sulfur (S) from customer, Responsibility is on customer.

12.3 Caution against static charge

The LCD module uses C-MOS LSI drivers, so we recommend that you:

Connect any unused input terminal to power or ground, do not input any signals before power is turned on, and ground your body, work/assembly areas, and assembly equipment to protect against static electricity.

12.4 packing

- Module employs LCD elements and must be treated as such.
- Avoid intense shock and falls from a height.
- To prevent modules from degradation, do not operate or store them exposed direct to sunshine or high temperature/humidity

12.5 Caution for operation

- It is an indispensable condition to drive LCD's within the specified voltage limit since the higher voltage than the limit causes the shorter LCD life.
- An electrochemical reaction due to direct current causes LCD's undesirable deterioration, so that the use of direct current drive should be avoided.
- Response time will be extremely delayed at lower temperature than the operating temperature range and on the other hand at higher temperature LCD's show dark color in them. However those phenomena do not mean malfunction or out of order with LCD's, which will come back in the specified operation temperature.
- If the display area is pushed hard during operation, some font will be abnormally displayed but it resumes normal condition after turning off once.
- Slight dew depositing on terminals is a cause for electro-chemical reaction resulting in terminal open circuit.



Product Specification	Model:	AWY-800480T70P04	Rev. No.	Issued Date.	Page.
			B	2016/01/06	22/22

Usage under the maximum operating temperature, 50%Rh or less is required.

12.6 storing

In the case of storing for a long period of time for instance, for years for the purpose or replacement use, the following ways are recommended.

- Storage in a polyethylene bag with the opening sealed so as not to enter fresh air outside in it. And with no desiccant.
- Placing in a dark place where neither exposure to direct sunlight nor light's keeping the storage temperature range.
- Storing with no touch on polarizer surface by the anything else.

[It is recommended to store them as they have been contained in the inner container at the time of delivery from us

12.7 Safety

- It is recommendable to crash damaged or unnecessary LCD's into pieces and wash off liquid crystal by either of solvents such as acetone and ethanol, which should be burned up later.
- When any liquid leaked out of a damaged glass cell comes in contact with your hands, please wash it off well with soap and water

13. Precaution for Use

13.1

A limit sample should be provided by the both parties on an occasion when the both parties agreed its necessity. Judgment by a limit sample shall take effect after the limit sample has been established and confirmed by the both parties.

13.2

On the following occasions, the handing of problem should be decided through discussion and agreement between responsible of the both parties.

- When a question is arisen in this specification
- When a new problem is arisen which is not specified in this specifications
- When an inspection specifications change or operating condition change in customer is reported to ACROWISE TFT, and some problem is arisen in this specification due to the change
- When a new problem is arisen at the customer's operating set for sample evaluation in the customer site.



Компания «ЭлектроПласт» предлагает заключение долгосрочных отношений при поставках импортных электронных компонентов на взаимовыгодных условиях!

Наши преимущества:

- Оперативные поставки широкого спектра электронных компонентов отечественного и импортного производства напрямую от производителей и с крупнейших мировых складов;
- Поставка более 17-ти миллионов наименований электронных компонентов;
- Поставка сложных, дефицитных, либо снятых с производства позиций;
- Оперативные сроки поставки под заказ (от 5 рабочих дней);
- Экспресс доставка в любую точку России;
- Техническая поддержка проекта, помощь в подборе аналогов, поставка прототипов;
- Система менеджмента качества сертифицирована по Международному стандарту ISO 9001;
- Лицензия ФСБ на осуществление работ с использованием сведений, составляющих государственную тайну;
- Поставка специализированных компонентов (Xilinx, Altera, Analog Devices, Intersil, Interpoint, Microsemi, Aeroflex, Peregrine, Syfer, Eurofarad, Texas Instrument, Miteq, Cobham, E2V, MA-COM, Hittite, Mini-Circuits, General Dynamics и др.);

Помимо этого, одним из направлений компании «ЭлектроПласт» является направление «Источники питания». Мы предлагаем Вам помощь Конструкторского отдела:

- Подбор оптимального решения, техническое обоснование при выборе компонента;
- Подбор аналогов;
- Консультации по применению компонента;
- Поставка образцов и прототипов;
- Техническая поддержка проекта;
- Защита от снятия компонента с производства.



Как с нами связаться

Телефон: 8 (812) 309 58 32 (многоканальный)

Факс: 8 (812) 320-02-42

Электронная почта: org@eplast1.ru

Адрес: 198099, г. Санкт-Петербург, ул. Калинина, дом 2, корпус 4, литера А.