

## FEATURES

**Complete quad, 16-bit digital-to-analog converter (DAC)**  
**Programmable output range:  $\pm 4.096$  V,  $\pm 4.201$  V, or  $\pm 4.311$  V**  
 **$\pm 1$  LSB maximum INL error,  $\pm 1$  LSB maximum DNL error**  
**Low noise: 70 nV/ $\sqrt{\text{Hz}}$**   
**Settling time: 10  $\mu\text{s}$  maximum**  
**Integrated reference buffers**  
**On-chip die temperature sensor**  
**Output control during power-up/brownout**  
**Programmable short-circuit protection**  
**Simultaneous updating via LDAC**  
**Asynchronous CLR to zero code**  
**Digital offset and gain adjustment**  
**Logic output control pins**  
**DSP-/microcontroller-compatible serial interface**  
**Temperature range:  $-40^{\circ}\text{C}$  to  $+105^{\circ}\text{C}$**   
**iCMOS<sup>®</sup> process technology<sup>1</sup>**

## APPLICATIONS

**Industrial automation**  
**Open-/closed-loop servo control**  
**Process control**  
**Data acquisition systems**  
**Automatic test equipment**  
**Automotive test and measurement**  
**High accuracy instrumentation**

## GENERAL DESCRIPTION

The [AD5765](#) is a quad, 16-bit, serial input, bipolar voltage output, digital-to-analog converter (DAC) that operates from supply voltages of  $\pm 4.75$  V to  $\pm 5.25$  V. The nominal full-scale output range is  $\pm 4.096$  V. The [AD5765](#) provides integrated output amplifiers, reference buffers, and proprietary power-up/power-down control circuitry. The part also features a digital I/O port, which is programmed via the serial interface. The part incorporates digital offset and gain adjustment registers per channel.

The [AD5765](#) is a high performance converter that offers guaranteed monotonicity, integral nonlinearity (INL) of  $\pm 1$  LSB, low noise, and 10  $\mu\text{s}$  settling time. During power-up (when the supply voltages are changing), the outputs are clamped to 0 V via a low impedance path.

The [AD5765](#) uses a serial interface that operates at clock rates of up to 30 MHz and is compatible with DSP and microcontroller interface standards. Double buffering allows the simultaneous updating of all DACs. The input coding is programmable to either a twos complement or an offset binary format. The asynchronous clear function clears all DAC registers to either bipolar zero or zero scale, depending on the coding used. The [AD5765](#) is ideal for both closed-loop servo control and open-loop control applications. The [AD5765](#) is available in a 32-lead TQFP and offers guaranteed specifications over the  $-40^{\circ}\text{C}$  to  $+105^{\circ}\text{C}$  industrial temperature range. Figure 1 contains a functional block diagram of the [AD5765](#).

**Table 1. Related Devices**

Part No.	Description
<a href="#">AD5764</a>	Complete quad, 16-bit, high accuracy, serial input, $\pm 10$ V DAC
<a href="#">AD5763</a>	Complete dual, 16-bit, high accuracy, serial input, $\pm 5$ V DAC

<sup>1</sup> For analog systems designers within industrial/instrumentation equipment OEMs who need high performance ICs at higher voltage levels, iCMOS is a technology platform that enables the development of analog ICs capable of 30 V and operating at  $\pm 15$  V supplies, allowing dramatic reductions in power consumption and package size and increased ac and dc performance.

### Rev. C

Information furnished by Analog Devices is believed to be accurate and reliable. However, no responsibility is assumed by Analog Devices for its use, nor for any infringements of patents or other rights of third parties that may result from its use. Specifications subject to change without notice. No license is granted by implication or otherwise under any patent or patent rights of Analog Devices. Trademarks and registered trademarks are the property of their respective owners.

## TABLE OF CONTENTS

Features .....	1	Data Register .....	20
Applications .....	1	Coarse Gain Register .....	20
General Description .....	1	Fine Gain Register .....	21
Revision History .....	2	Offset Register .....	21
Functional Block Diagram .....	3	Offset and Gain Adjustment Worked Example.....	22
Specifications.....	4	Design Features.....	23
AC Performance Characteristics .....	6	Analog Output Control .....	23
Timing Characteristics .....	7	Digital Offset and Gain Control.....	23
Absolute Maximum Ratings.....	10	Programmable Short-Circuit Protection .....	23
Thermal Resistance .....	10	Digital I/O Port.....	23
ESD Caution.....	10	Die Temperature Sensor .....	23
Pin Configuration and Function Descriptions.....	11	Local-Ground-Offset Adjustment .....	23
Typical Performance Characteristics .....	13	Power-On Status.....	24
Terminology .....	16	Applications Information.....	25
Theory of Operation .....	17	Typical Operating Circuit .....	25
DAC Architecture.....	17	Precision Voltage Reference Selection.....	25
Reference Buffers.....	17	Layout Guidelines.....	26
Serial Interface .....	17	Galvanically Isolated Interface .....	26
Simultaneous Updating via $\overline{\text{LDAC}}$ .....	18	Microprocessor Interfacing.....	26
Transfer Function .....	19	Outline Dimensions .....	27
Asynchronous Clear ( $\overline{\text{CLR}}$ ).....	19	Ordering Guide .....	27
Function Register .....	20		

## REVISION HISTORY

### 10/11—Rev. B to Rev. C

Changed 50 MHz to 30 MHz.....	Throughout
Changes to $t_1$ , $t_2$ , and $t_3$ Parameters, Table 4.....	7

### 7/11—Rev. A to Rev. B

Changed 30 MHz to 50 MHz Throughout.....	1
Changes to $t_1$ , $t_2$ , and $t_3$ Parameters, Table 4.....	7
Changes to Table 21.....	25
Changes to Ordering Guide .....	27

### 10/09—Rev. 0 to Rev. A

Deleted Endnote 1, Table 2.....	4
Deleted Endnote 1, Table 3.....	6
Deleted Endnote 1, Table 4.....	7
Changes to $t_6$ Parameter, Table 4 .....	7

### 1/09—Revision 0: Initial Version

FUNCTIONAL BLOCK DIAGRAM

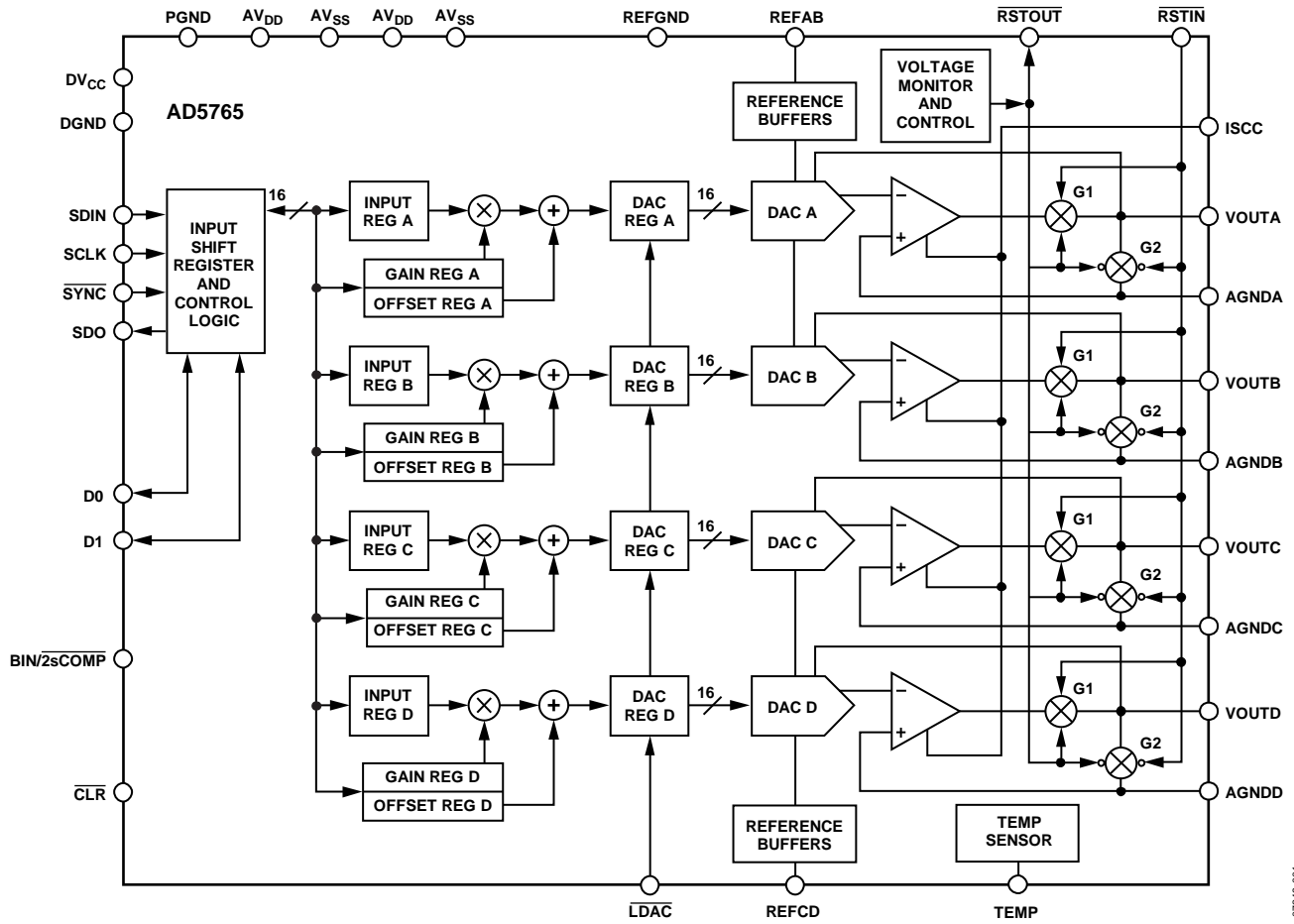

Figure 1.

07248-001

## SPECIFICATIONS

$AV_{DD} = 4.75\text{ V to }5.25\text{ V}$ ,  $AV_{SS} = -4.75\text{ V to }-5.25\text{ V}$ ,  $AGND_x = DGND = REFGND = PGND = 0\text{ V}$ ,  $REFAB = REFCD = 2.048\text{ V}$ ,  $DV_{CC} = 2.7\text{ V to }5.25\text{ V}$ ,  $R_{LOAD} = 5\text{ k}\Omega$ ,  $C_{LOAD} = 200\text{ pF}$ . All specifications  $T_{MIN}$  to  $T_{MAX}$ , unless otherwise noted.

Table 2.

Parameter	B Grade <sup>1</sup>	C Grade <sup>1</sup>	Unit	Test Conditions/Comments
ACCURACY				Outputs unloaded
Resolution	16	16	Bits	
Relative Accuracy (INL)	$\pm 2$	$\pm 1$	LSB max	
Differential Nonlinearity (DNL)	$\pm 1$	$\pm 1$	LSB max	Guaranteed monotonic
Bipolar Zero Error	$\pm 2$	$\pm 2$	mV max	At 25°C
	$\pm 3$	$\pm 3$	mV max	
Bipolar Zero Temperature Coefficient (TC) <sup>2</sup>	$\pm 1$	$\pm 1$	ppm FSR/°C typ	
Zero-Scale Error	$\pm 2$	$\pm 2$	mV max	At 25°C
	$\pm 3.5$	$\pm 3.5$	mV max	
Zero-Scale Temperature Coefficient (TC) <sup>2</sup>	$\pm 1$	$\pm 1$	ppm FSR/°C typ	
Gain Error	$\pm 0.03$	$\pm 0.03$	% FSR max	At 25°C, coarse gain register = 0
	$\pm 0.04$	$\pm 0.04$	% FSR max	Coarse gain register = 0
Gain TC <sup>2</sup>	$\pm 1$	$\pm 1$	ppm FSR/°C typ	
DC Crosstalk <sup>2</sup>	0.5	0.5	LSB max	
REFERENCE INPUT <sup>2</sup>				
Reference Input Voltage	2.048	2.048	V nominal	$\pm 1\%$ for specified performance
DC Input Impedance	1	1	M $\Omega$ min	Typically, 100 M $\Omega$
Input Current	$\pm 10$	$\pm 10$	$\mu\text{A}$ max	Typically, $\pm 30\text{ nA}$
Reference Range	1 to 2.1	1 to 2.1	V min to V max	
OUTPUT CHARACTERISTICS <sup>2</sup>				
Output Voltage Range <sup>3</sup>	$\pm 4.31158$ $\pm 4.20103$ $\pm 4.096$ $\pm 4.42105$	$\pm 4.31158$ $\pm 4.20103$ $\pm 4.096$ $\pm 4.42105$	V min/V max V min/V max V min/V max V min/V max	Coarse gain register = 2 Coarse gain register = 1 Coarse gain register = 0 $V_{REFIN} = 2.1\text{ V}$ , coarse gain register = 2
Output Voltage Drift vs. Time	$\pm 32$ $\pm 37$	$\pm 32$ $\pm 37$	ppm FSR/500 hours typ ppm FSR/1000 hours typ	
Short-Circuit Current	10	10	mA typ	$R_{ISCC} = 6\text{ k}\Omega$ ; see Figure 23
Load Current	$\pm 1$	$\pm 1$	mA max	For specified performance
Capacitive Load Stability				
$R_{LOAD} = \infty$	200	200	pF max	
$R_{LOAD} = 10\text{ k}\Omega$	1000	1000	pF max	
DC Output Impedance	0.3	0.3	$\Omega$ max	
DIGITAL INPUTS <sup>2</sup>				$DV_{CC} = 2.7\text{ V to }5.25\text{ V}$ , JEDEC compliant
$V_{IH}$ , Input High Voltage	2	2	V min	
$V_{IL}$ , Input Low Voltage	0.8	0.8	V max	
Input Current	$\pm 1$	$\pm 1$	$\mu\text{A}$ max	Per pin
Pin Capacitance	10	10	pF max	Per pin

Parameter	B Grade <sup>1</sup>	C Grade <sup>1</sup>	Unit	Test Conditions/Comments
DIGITAL OUTPUTS (D0, D1, SDO) <sup>2</sup>				
Output Low Voltage	0.4	0.4	V max	DV <sub>CC</sub> = 5 V ± 5%, sinking 200 μA
Output High Voltage	DV <sub>CC</sub> – 1	DV <sub>CC</sub> – 1	V min	DV <sub>CC</sub> = 5 V ± 5%, sourcing 200 μA
Output Low Voltage	0.4	0.4	V max	DV <sub>CC</sub> = 2.7 V to 3.6 V, sinking 200 μA
Output High Voltage	DV <sub>CC</sub> – 0.5	DV <sub>CC</sub> – 0.5	V min	DV <sub>CC</sub> = 2.7 V to 3.6 V, sourcing 200 μA
High Impedance Leakage Current	±1	±1	μA max	SDO only
High Impedance Output Capacitance	5	5	pF typ	SDO only
DIE TEMPERATURE SENSOR				
Output Voltage at 25°C	1.44	1.44	V typ	
Output Voltage Scale Factor	3	3	mV/°C typ	
Output Voltage Range	1.175 to 1.9	1.175 to 1.9	V min to V max	
Output Load Current	200	200	μA max	
Power-On Time	10	10	ms typ	
POWER REQUIREMENTS				
AV <sub>DD</sub> /AV <sub>SS</sub>	4.75 to 5.25	4.75 to 5.25	V min to V max	
DV <sub>CC</sub>	2.7 to 5.25	2.7 to 5.25	V min to V max	
AI <sub>DD</sub>	2.25	2.25	mA/channel max	Outputs unloaded
AI <sub>SS</sub>	1.9	1.9	mA/channel max	Outputs unloaded
DI <sub>CC</sub>	1.2	1.2	mA max	V <sub>IH</sub> = DV <sub>CC</sub> , V <sub>IL</sub> = DGND, 750 μA typ
Power Supply Sensitivity <sup>2</sup>				
ΔV <sub>OUT</sub> /ΔAV <sub>DD</sub>	–110	–110	dB typ	
Power Dissipation	76	76	mW typ	±5 V operation output unloaded

<sup>1</sup> Temperature range: –40°C to +105°C; typical at +25°C.

<sup>2</sup> Guaranteed by design and characterization; not production tested.

<sup>3</sup> Output amplifier headroom requirement is 0.5 V minimum.

**AC PERFORMANCE CHARACTERISTICS**

$AV_{DD} = 4.75\text{ V to }5.25\text{ V}$ ,  $AV_{SS} = -4.75\text{ V to }-5.25\text{ V}$ ,  $AGND_x = DGND = REFGND = PGND = 0\text{ V}$ ,  $REFAB = REFCD = 2.048\text{ V}$ ,  $DV_{CC} = 2.7\text{ V to }5.25\text{ V}$ ,  $R_{LOAD} = 5\text{ k}\Omega$ ,  $C_{LOAD} = 200\text{ pF}$ . All specifications  $T_{MIN}$  to  $T_{MAX}$ , unless otherwise noted.

**Table 3.**

Parameter	B Grade	C Grade	Unit	Test Conditions/Comments
<b>DYNAMIC PERFORMANCE<sup>1</sup></b>				
Output Voltage Settling Time	8	8	$\mu\text{s typ}$	Full-scale step to $\pm 1\text{ LSB}$
	10	10	$\mu\text{s max}$	
	2	2	$\mu\text{s typ}$	
Slew Rate	5	5	$\text{V}/\mu\text{s typ}$	512 LSB step settling
Digital-to-Analog Glitch Energy	20	20	$\text{nV}\cdot\text{sec typ}$	
Glitch Impulse Peak Amplitude	30	30	$\text{mV typ}$	
Channel-to-Channel Isolation	60	60	$\text{dB typ}$	
DAC-to-DAC Crosstalk	8	8	$\text{nV}\cdot\text{sec typ}$	
Digital Crosstalk	2	2	$\text{nV}\cdot\text{sec typ}$	
Digital Feedthrough	2	2	$\text{nV}\cdot\text{sec typ}$	Effect of input bus activity on DAC outputs
Output Noise, 0.1 Hz to 10 Hz	0.1	0.1	$\text{LSB p-p typ}$	
Output Noise, 0.1 Hz to 100 kHz	50	50	$\mu\text{V rms typ}$	
1/f Corner Frequency	300	300	$\text{Hz typ}$	
Output Noise Spectral Density	70	70	$\text{nV}/\sqrt{\text{Hz typ}}$	Measured at 10 kHz
Complete System Output Noise Spectral Density <sup>2</sup>	80	80	$\text{nV}/\sqrt{\text{Hz typ}}$	Measured at 10 kHz

<sup>1</sup> Guaranteed by design and characterization; not production tested.

<sup>2</sup> Includes noise contributions from integrated reference buffers, 16-bit DAC, and output amplifier.

**TIMING CHARACTERISTICS**

$AV_{DD} = 4.75\text{ V to }5.25\text{ V}$ ,  $AV_{SS} = -4.75\text{ V to }-5.25\text{ V}$ ,  $AGND_x = DGND = REFGND = PGND = 0\text{ V}$ ,  $REFAB = REFCD = 2.048\text{ V}$ ,  $DV_{CC} = 2.7\text{ V to }5.25\text{ V}$ ,  $R_{LOAD} = 5\text{ k}\Omega$ ,  $C_{LOAD} = 200\text{ pF}$ . All specifications  $T_{MIN}$  to  $T_{MAX}$ , unless otherwise noted.

**Table 4.**

Parameter <sup>1, 2, 3</sup>	Limit at $T_{MIN}, T_{MAX}$	Unit	Description
$t_1$	33	ns min	SCLK cycle time
$t_2$	13	ns min	SCLK high time
$t_3$	13	ns min	SCLK low time
$t_4$	13	ns min	$\overline{SYNC}$ falling edge to SCLK falling edge setup time
$t_5^4$	13	ns min	24 <sup>th</sup> SCLK falling edge to $\overline{SYNC}$ rising edge
$t_6$	90	ns min	Minimum $\overline{SYNC}$ high time
$t_7$	2	ns min	Data setup time
$t_8$	5	ns min	Data hold time
$t_9$	1.7	$\mu\text{s min}$	$\overline{SYNC}$ rising edge to $\overline{LDAC}$ falling edge when all DACs are updated
	480	ns min	$\overline{SYNC}$ rising edge to $\overline{LDAC}$ falling edge when a single DAC is updated
$t_{10}$	10	ns min	$\overline{LDAC}$ pulse width low
$t_{11}$	500	ns max	$\overline{LDAC}$ falling edge to DAC output response time
$t_{12}$	10	$\mu\text{s max}$	DAC output settling time
$t_{13}$	10	ns min	$\overline{CLR}$ pulse width low
$t_{14}$	2	$\mu\text{s max}$	$\overline{CLR}$ pulse activation time
$t_{15}^{5, 6}$	25	ns max	SCLK rising edge to SDO valid
$t_{16}$	13	ns min	$\overline{SYNC}$ rising edge to SCLK falling edge
$t_{17}$	2	$\mu\text{s max}$	$\overline{SYNC}$ rising edge to DAC output response time ( $\overline{LDAC} = 0$ )
$t_{18}$	170	ns min	$\overline{LDAC}$ falling edge to $\overline{SYNC}$ rising edge

<sup>1</sup> Guaranteed by design and characterization; not production tested.

<sup>2</sup> All input signals are specified with  $t_r = t_f = 5\text{ ns}$  (10% to 90% of  $DV_{CC}$ ) and timed from a voltage level of 1.2 V.

<sup>3</sup> See Figure 2, Figure 3, and Figure 4.

<sup>4</sup> Standalone mode only.

<sup>5</sup> Measured with the load circuit of Figure 5.

<sup>6</sup> Daisy-chain mode only.

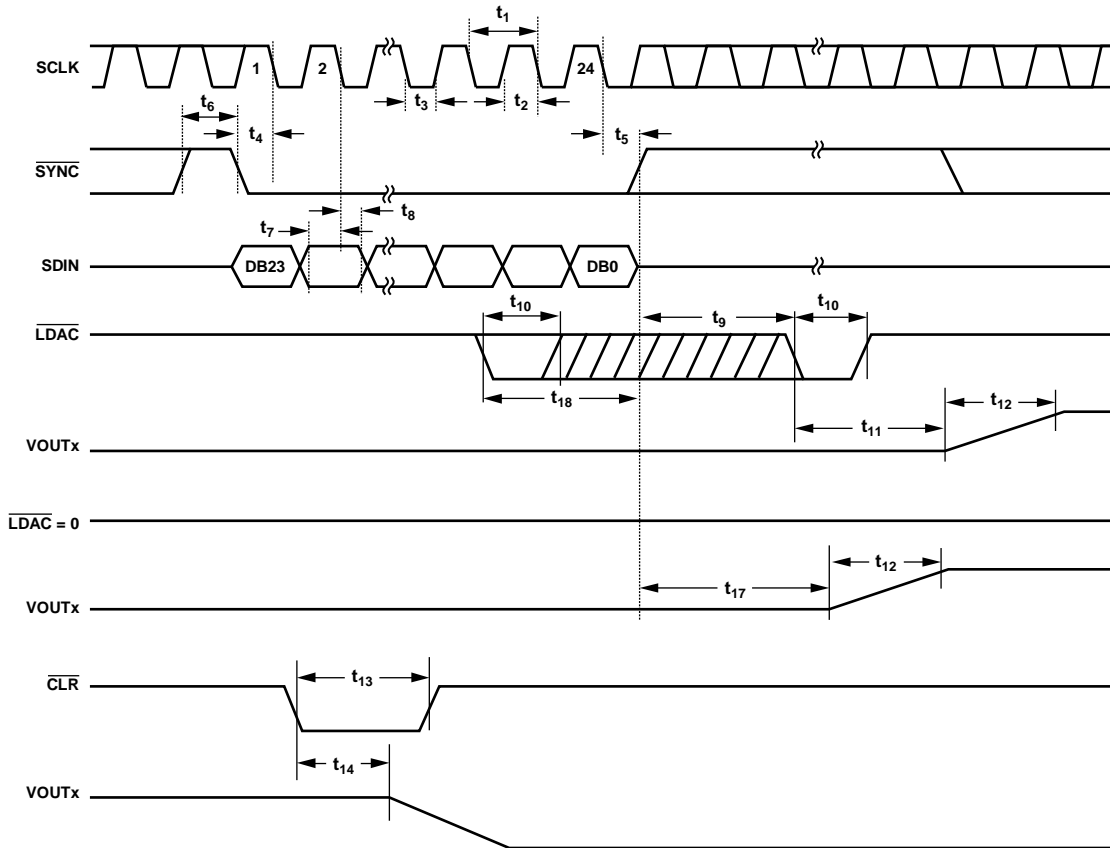

07249-002

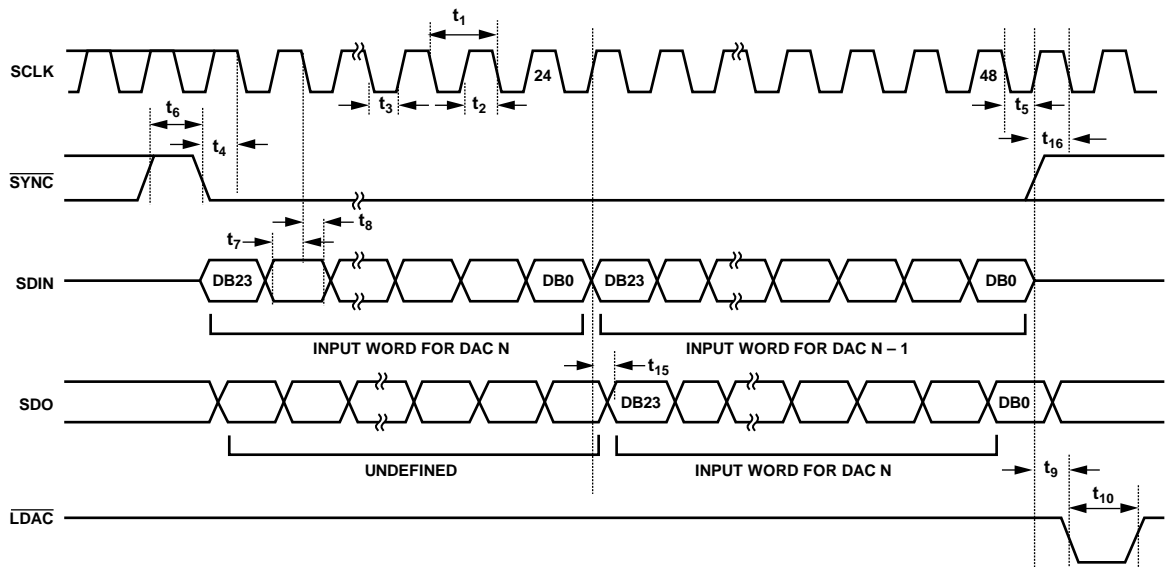

07249-003



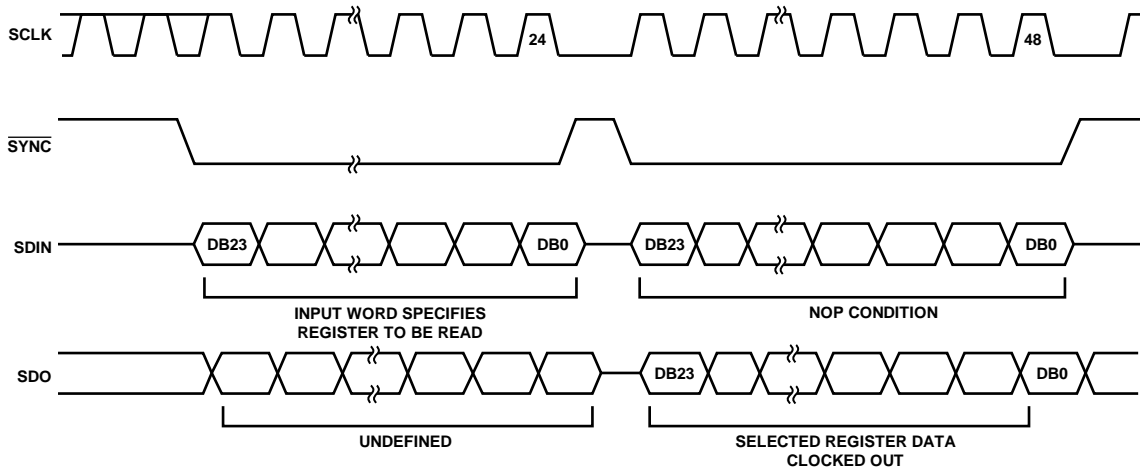

07249-004

Figure 4. Readback Timing Diagram

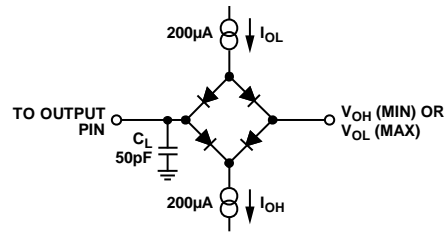

07249-005

Figure 5. Load Circuit for SDO Timing Diagram

## ABSOLUTE MAXIMUM RATINGS

$T_A = 25^\circ\text{C}$ , unless otherwise noted. Transient currents of up to 100 mA do not cause SCR latch-up.

Table 5.

Parameter	Rating
$AV_{DD}$ to AGNDx, DGND	-0.3 V to +7 V
$AV_{SS}$ to AGNDx, DGND	+0.3 V to -7 V
$DV_{CC}$ to DGND	-0.3 V to +7 V
$DV_{CC}$ to AVDD	- $DV_{CC}$ to +0.25 V
Digital Inputs to DGND	-0.3 V to $DV_{CC} + 0.3$ V or 7 V (whichever is less)
Digital Outputs to DGND	-0.3 V to $DV_{CC} + 0.3$ V
REFx to AGNDx, PGND	-0.3 V to $AV_{DD} + 0.3$ V
VOUx to AGNDx	$AV_{SS}$ to $AV_{DD}$
AGNDx to DGND	-0.3 V to +0.3 V
Operating Temperature Range ( $T_A$ )	
Industrial	-40°C to +105°C
Storage Temperature Range	-65°C to +150°C
Junction Temperature ( $T_J$ max)	150°C
Power Dissipation	$(T_J \text{ max} - T_A)/\theta_{JA}$
Lead Temperature	JEDEC industry standard
Soldering	J-STD-020

Stresses above those listed under Absolute Maximum Ratings may cause permanent damage to the device. This is a stress rating only; functional operation of the device at these or any other conditions above those listed in the operational sections of this specification is not implied. Exposure to absolute maximum rating conditions for extended periods may affect device reliability.

### THERMAL RESISTANCE

$\theta_{JA}$  is specified for the worst-case conditions, that is, a device soldered in a circuit board for surface-mount packages.

Table 6. Thermal Resistance

Package Type	$\theta_{JA}$	$\theta_{JC}$	Unit
32-Lead TQFP	65	12	$^\circ\text{C}/\text{W}$

### ESD CAUTION



**ESD (electrostatic discharge) sensitive device.** Charged devices and circuit boards can discharge without detection. Although this product features patented or proprietary protection circuitry, damage may occur on devices subjected to high energy ESD. Therefore, proper ESD precautions should be taken to avoid performance degradation or loss of functionality.

# PIN CONFIGURATION AND FUNCTION DESCRIPTIONS

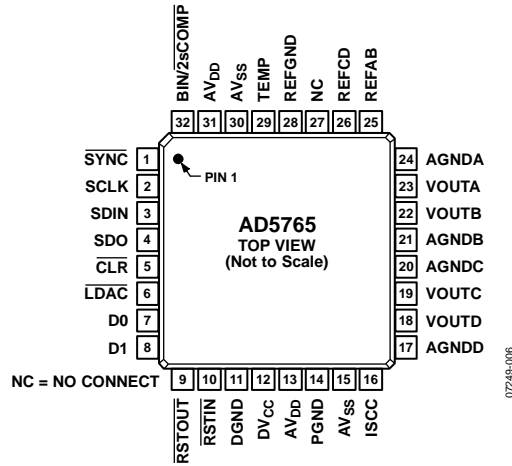

Figure 6. Pin Configuration

Table 7. Pin Function Descriptions

Pin No.	Mnemonic	Description
1	SYNC	Active Low Input. This is the frame synchronization signal for the serial interface. While SYNC is low, data is transferred in on the falling edge of SCLK.
2	SCLK	Serial Clock Input. Data is clocked into the shift register on the falling edge of SCLK. This operates at clock speeds of up to 30 MHz.
3	SDIN	Serial Data Input. Data must be valid on the falling edge of SCLK.
4	SDO	Serial Data Output. This is used to clock data from the serial register in daisy-chain or readback mode.
5 <sup>1</sup>	CLR	Negative Edge Triggered Input. Asserting this pin sets the DAC registers to 0x0000.
6	LDAC	Load DAC. Logic input. This is used to update the DAC registers and consequently the analog outputs. When tied permanently low, the addressed DAC register is updated on the rising edge of SYNC. If LDAC is held high during the write cycle, the DAC input register is updated but the output update is held off until the falling edge of LDAC. In this mode, all analog outputs can be updated simultaneously on the falling edge of LDAC. The LDAC pin must not be left unconnected.
7, 8	D0, D1	D0 and D1 form a digital I/O port. The user can set up these pins as inputs or outputs that are configurable and readable over the serial interface. When configured as inputs, these pins have weak internal pull-ups to DVCC. When programmed as outputs, D0 and D1 are referenced by DVCC and DGND.
9	RSTOUT	Reset Logic Output. This is the output from the on-chip voltage monitor used in the reset circuit. If desired, it can be used to control other system components.
10	RSTIN	Reset Logic Input. This input allows external access to the internal reset logic. Applying a Logic 0 to this input clamps the DAC outputs to 0 V. In normal operation, RSTIN should be tied to Logic 1. Register values remain unchanged.
11	DGND	Digital Ground Pin.
12	DVCC	Digital Supply Pin. Voltage ranges from 2.7 V to 5.25 V.
13, 31	AVDD	Positive Analog Supply Pins. Voltage ranges from 4.75 V to 5.25 V.
14	PGND	Ground Reference Point for Analog Circuitry.
15, 30	AVSS	Negative Analog Supply Pins. Voltage ranges from -4.75 V to -5.25 V.
16	ISCC	This pin is used in association with an optional external resistor to AGND to program the short-circuit current of the output amplifiers. See the Design Features section for additional details.
17	AGNDD	Ground Reference Pin for the DAC D Output Amplifier.
18	VOUTD	Analog Output Voltage of DAC D. This provides buffered output with a nominal full-scale output range of ±4.096 V. The output amplifier is capable of directly driving a 5 kΩ, 200 pF load.

Pin No.	Mnemonic	Description
19	VOUTC	Analog Output Voltage of DAC C. This provides buffered output with a nominal full-scale output range of $\pm 4.096$ V. The output amplifier is capable of directly driving a 5 k $\Omega$ , 200 pF load.
20	AGNDC	Ground Reference Pin for the DAC C Output Amplifier.
21	AGNDB	Ground Reference Pin for the DAC B Output Amplifier.
22	VOUTB	Analog Output Voltage of DAC B. This provides buffered output with a nominal full-scale output range of $\pm 4.096$ V. The output amplifier is capable of directly driving a 5 k $\Omega$ , 200 pF load.
23	VOUTA	Analog Output Voltage of DAC A. This provides buffered output with a nominal full-scale output range of $\pm 4.096$ V. The output amplifier is capable of directly driving a 5 k $\Omega$ , 200 pF load.
24	AGNDA	Ground Reference Pin for the DAC A Output Amplifier.
25	REFAB	External Reference Voltage Input for Channel A and Channel B. The reference input range is 1 V to 2.1 V; this programs the full-scale output voltage. $V_{REFIN} = 2.048$ V for specified performance.
26	REFCD	External Reference Voltage Input for Channel C and Channel D. The reference input range is 1 V to 2.1 V; this programs the full-scale output voltage. $V_{REFIN} = 2.048$ V for specified performance.
27	NC	No Connect.
28	REFGND	Reference Ground Return for the Reference Generator and Buffers.
29	TEMP	This pin provides an output voltage proportional to temperature. The output voltage is 1.4 V, typical, at 25°C die temperature; variation with temperature is 5 mV/°C.
32	BIN/ <u>2sCOMP</u>	Determines the DAC Coding. This pin should be hardwired to either DV <sub>CC</sub> or DGND. When hardwired to DV <sub>CC</sub> , input coding is offset binary. When hardwired to DGND, input coding is twos complement (see Table 8).

<sup>1</sup> Internal pull-up device on this logic input. Therefore, it can be left floating and defaults to a logic high condition.

# TYPICAL PERFORMANCE CHARACTERISTICS

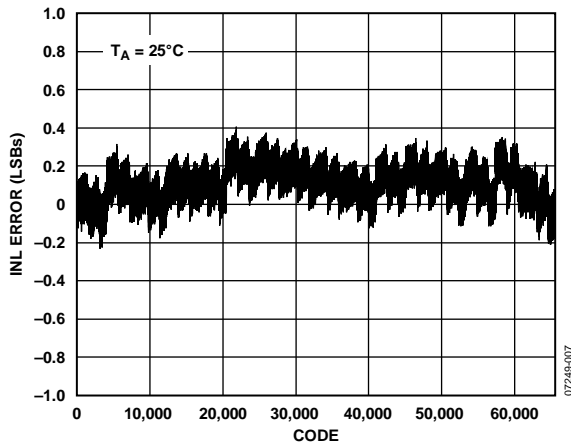

Figure 7. Integral Nonlinearity Error vs. Code

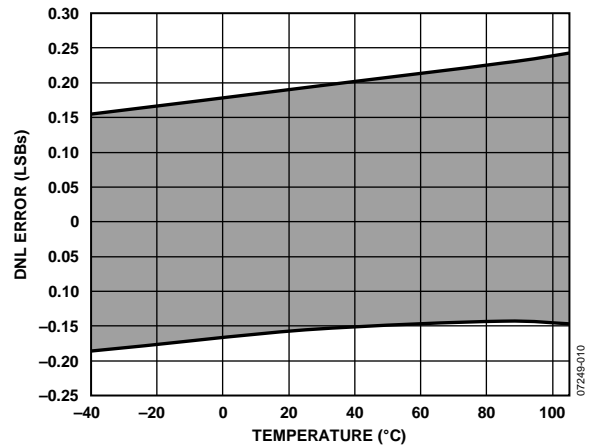

Figure 10. Differential Nonlinearity Error vs. Temperature

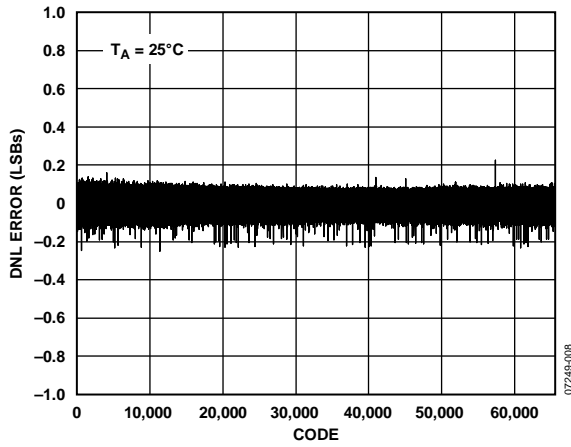

Figure 8. Differential Nonlinearity Error vs. Code

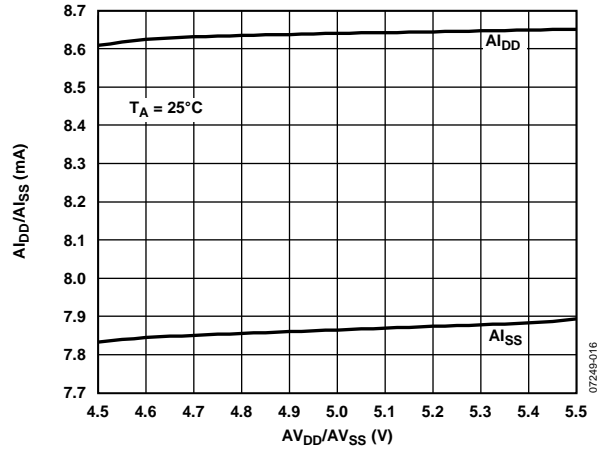

Figure 11.  $I_{BDP}/I_{LSS}$  vs.  $AV_{DD}/AV_{SS}$

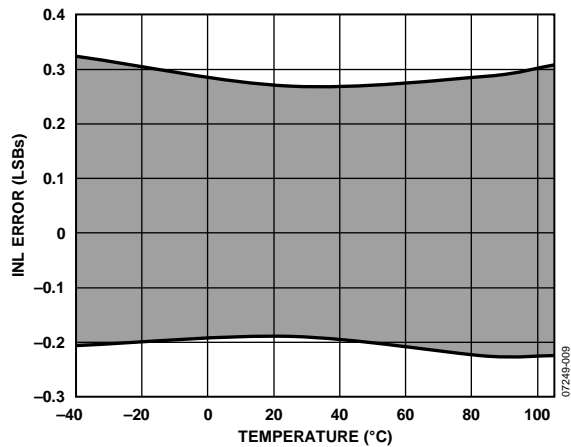

Figure 9. Integral Nonlinearity Error vs. Temperature

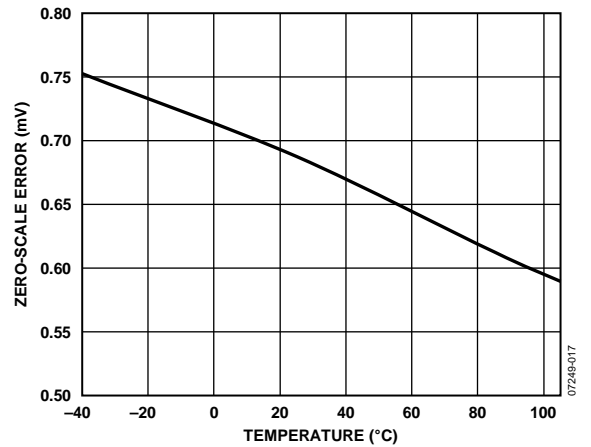

Figure 12. Zero-Scale Error vs. Temperature

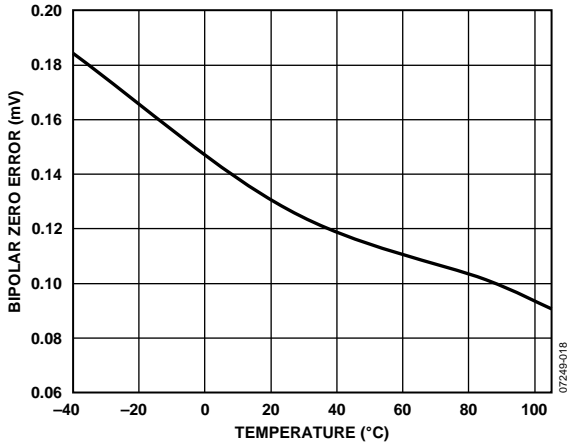

Figure 13. Bipolar Zero Error vs. Temperature

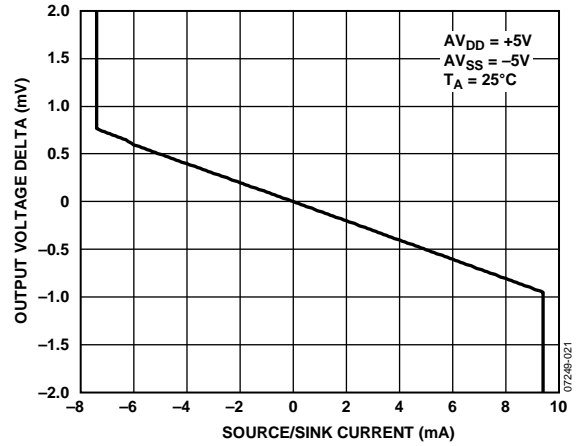

Figure 16. Source and Sink Capability of Output Amplifier with Positive Full-Scale Loaded

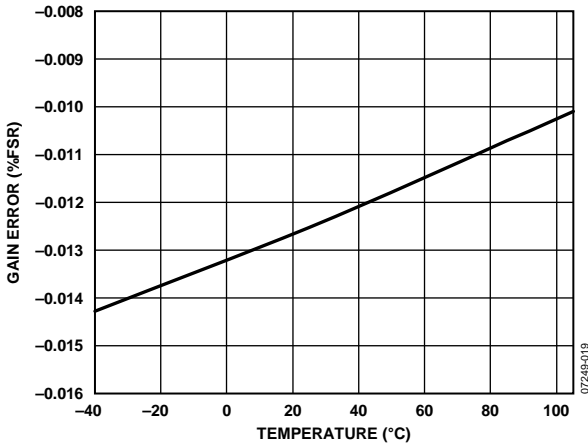

Figure 14. Gain Error vs. Temperature

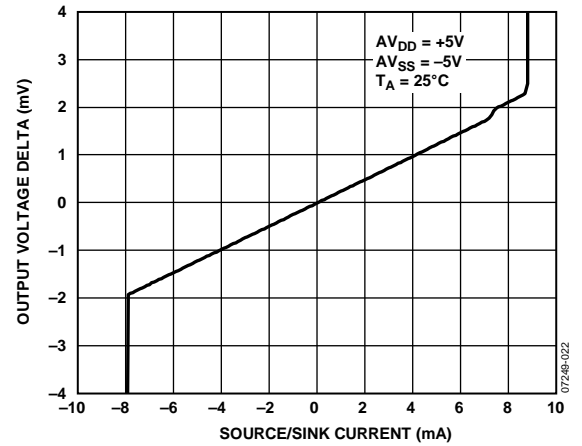

Figure 17. Source and Sink Capability of Output Amplifier with Negative Full-Scale Loaded

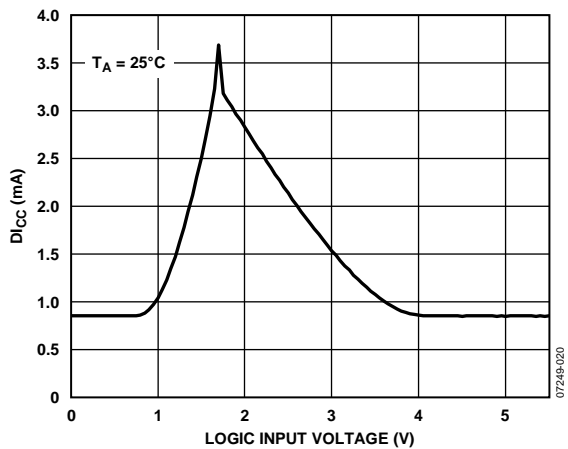

Figure 15. D<sub>ICC</sub> vs. Logic Input Voltage

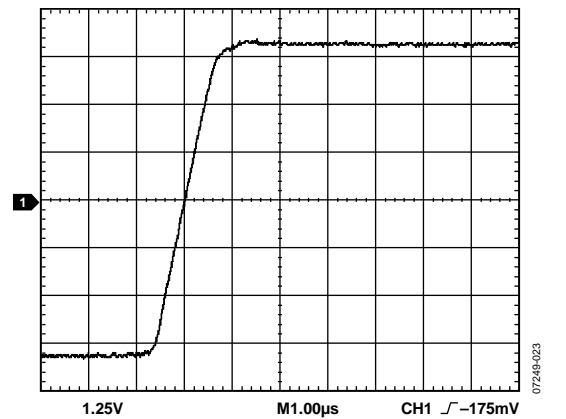

Figure 18. Positive Full-Scale Step

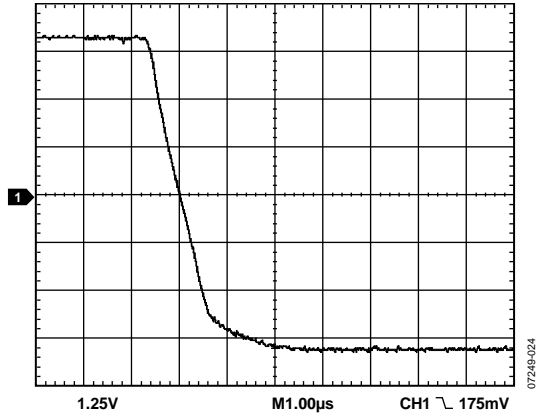

Figure 19. Negative Full-Scale Step

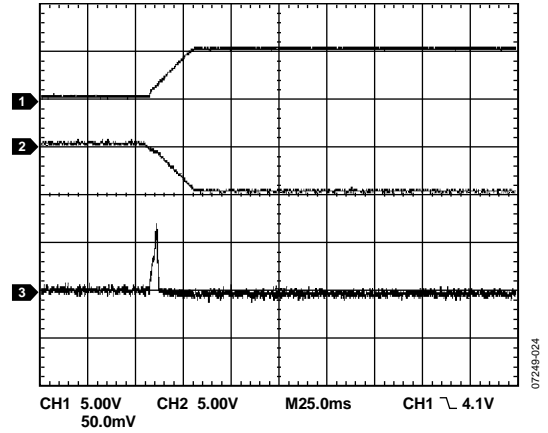

Figure 22. VOUT vs. AVDD/AVSS on Power-Up

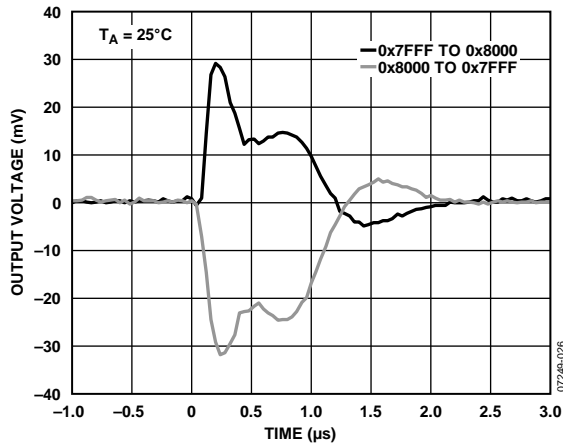

Figure 20. Major Code Transition Glitch Energy

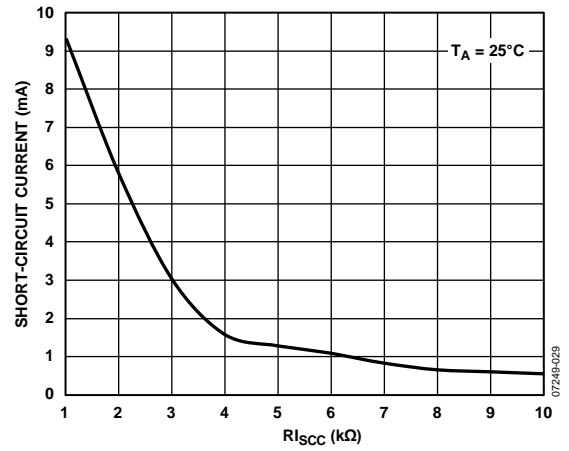

Figure 23. Short-Circuit Current vs. RLSC

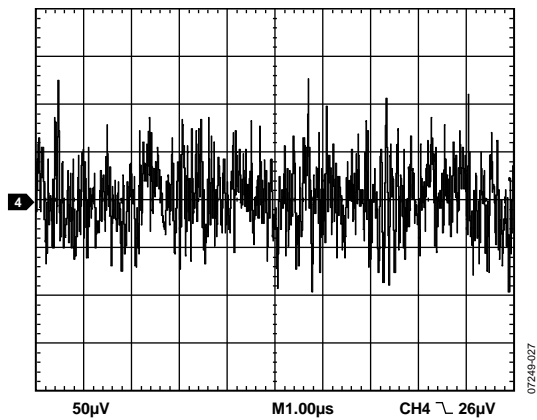

Figure 21. Peak-to-Peak Noise (100 kHz Bandwidth)

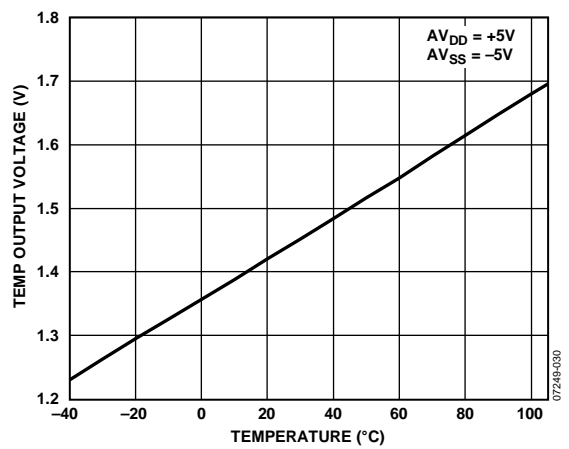

Figure 24. TEMP Output Voltage vs. Temperature

## TERMINOLOGY

### Relative Accuracy or Integral Nonlinearity (INL)

For the DAC, relative accuracy or integral nonlinearity (INL) is a measure of the maximum deviation, in LSBs, from a straight line passing through the endpoints of the DAC transfer function. A typical INL vs. code plot can be seen in Figure 7.

### Differential Nonlinearity (DNL)

Differential nonlinearity is the difference between the measured change and the ideal 1 LSB change between any two adjacent codes. A specified differential nonlinearity of  $\pm 1$  LSB maximum ensures monotonicity. This DAC is guaranteed monotonic. A typical DNL vs. code plot can be seen in Figure 8.

### Monotonicity

A DAC is monotonic if the output either increases or remains constant for increasing digital input code. The AD5765 is monotonic over its full operating temperature range.

### Bipolar Zero Error

Bipolar zero error is the deviation of the analog output from the ideal half-scale output of 0 V when the DAC register is loaded with 0x8000 (offset binary coding) or 0x0000 (twos complement coding). A plot of bipolar zero error vs. temperature can be seen in Figure 13.

### Bipolar Zero Temperature Coefficient (TC)

Bipolar zero temperature coefficient is the measure of the change in the bipolar zero error with a change in temperature. It is expressed as (ppm FSR)/°C.

### Full-Scale Error

Full-scale error is a measure of the output error when full-scale code is loaded to the DAC register. Ideally, the output voltage should be  $2 \times V_{REF} - 1$  LSB. Full-scale error is expressed as a percentage of the full-scale range.

### Negative Full-Scale Error/Zero Scale Error

Negative full-scale error is the error in the DAC output voltage when 0x0000 (offset binary coding) or 0x8000 (twos complement coding) is loaded to the DAC register. Ideally, the output voltage is  $-2 \times V_{REF}$ . A plot of zero-scale error vs. temperature can be seen in Figure 12.

### Output Voltage Settling Time

Output voltage settling time is the amount of time it takes for the output to settle to a specified level for a full-scale input change.

### Slew Rate

The slew rate of a device is a limitation in the rate of change of the output voltage. The output slewing speed of a voltage-output DAC is usually limited by the slew rate of the amplifier used at its output. Slew rate is measured from 10% to 90% of the output signal and is given in V/ $\mu$ s.

### Gain Error

Gain error is a measure of the span error of the DAC. It is the deviation in slope of the DAC transfer characteristic from the ideal, expressed as a percentage of the full-scale range. A plot of gain error vs. temperature can be seen in Figure 14.

### Total Unadjusted Error (TUE)

Total unadjusted error (TUE) is a measure of the output error considering all the various errors.

### Zero-Scale Error Temperature Coefficient

Zero-scale error temperature coefficient is a measure of the change in zero-scale error with a change in temperature. Zero-scale error TC is expressed as (ppm FSR)/°C.

### Gain Error Temperature Coefficient

Gain error temperature coefficient is a measure of the change in gain error with changes in temperature. Gain error temperature coefficient is expressed as (ppm of FSR)/°C.

### Digital-to-Analog Glitch Impulse

Digital-to-analog glitch impulse is the impulse injected into the analog output when the input code in the DAC register changes state. It is normally specified as the area of the glitch in nV-sec and is measured when the digital input code is changed by 1 LSB at the major carry transition, 0x7FFF to 0x8000 (see Figure 20).

### Digital Feedthrough

Digital feedthrough is a measure of the impulse injected into the analog output of the DAC from the digital inputs of the DAC but is measured when the DAC output is not updated. It is specified in nV-sec and is measured with a full-scale code change on the data bus, that is, from all 0s to all 1s and vice versa.

### Power Supply Sensitivity

Power supply sensitivity indicates how the output of the DAC is affected by changes in the power supply voltage.

### DC Crosstalk

DC crosstalk is the dc change in the output level of one DAC in response to a change in the output of another DAC. It is measured with a full-scale output change on one DAC while monitoring another DAC and is expressed in LSBs.

### DAC-to-DAC Crosstalk

DAC-to-DAC crosstalk is the glitch impulse transferred to the output of one DAC due to a digital code change and subsequent output change of another DAC. This includes both digital and analog crosstalk. It is measured by loading one of the DACs with a full-scale code change (all 0s to all 1s and vice versa) with LDAC low and monitoring the output of another DAC. The energy of the glitch is expressed in nV-sec.

### Channel-to-Channel Isolation

Channel-to-channel isolation is the ratio of the amplitude of the signal at the output of one DAC to a sine wave on the reference input of another DAC. It is measured in decibels.

### Digital Crosstalk

Digital crosstalk is a measure of the impulse injected into the analog output of one DAC from the digital inputs of another DAC but is measured when the DAC output is not updated. It is specified in nV-sec and measured with a full-scale code change on the data bus, that is, from all 0s to all 1s and vice versa.



## THEORY OF OPERATION

The AD5765 is a quad, 16-bit, serial input, bipolar voltage output DAC that operates from supply voltages of  $\pm 4.75$  V to  $\pm 5.25$  V and has a buffered output voltage of up to  $\pm 4.311$  V. Data is written to the AD5765 in a 24-bit word format, via a 3-wire serial interface. The device also offers an SDO pin, which is available for daisy-chaining or readback.

The AD5765 incorporates a power-on reset circuit, which ensures that the DAC registers power up loaded with 0x0000. The AD5765 features a digital I/O port that can be programmed via the serial interface, on-chip reference buffers and per channel digital gain, and offset registers.

### DAC ARCHITECTURE

The DAC architecture of the AD5765 consists of a 16-bit current mode segmented R-2R DAC. The simplified circuit diagram for the DAC section is shown in Figure 25.

The four MSBs of the 16-bit data-word are decoded to drive 15 switches, E1 to E15. Each of these switches connects one of the 15 matched resistors to either AGNDx or IOUT. The remaining 12 bits of the data-word drive switches S0 to S11 of the 12-bit R-2R ladder network.

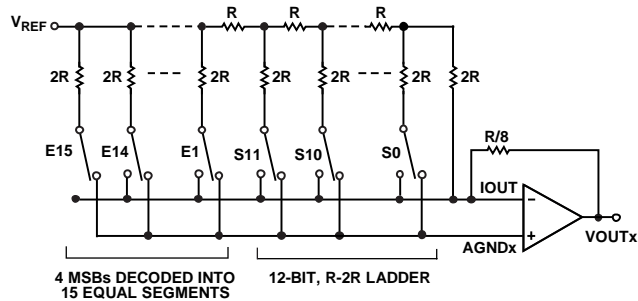

Figure 25. DAC Ladder Structure

### REFERENCE BUFFERS

The AD5765 operates with an external reference. The reference inputs (REFAB and REFCB) have an input range up to 2.1 V. This input voltage is then used to provide a buffered positive and negative reference for the DAC cores. The positive reference is given by

$$+V_{REF} = 2 V_{REF}$$

The negative reference to the DAC cores is given by

$$-V_{REF} = -2 V_{REF}$$

These positive and negative reference voltages (along with the gain register values) define the output ranges of the DACs.

### SERIAL INTERFACE

The AD5765 is controlled over a versatile 3-wire serial interface that operates at clock rates of up to 30 MHz and is compatible with SPI, QSPI™, MICROWIRE™, and DSP standards.

#### Input Shift Register

The input shift register is 24 bits wide. Data is loaded into the device MSB first as a 24-bit word under the control of a serial clock input, SCLK. The input register consists of a read/write bit, three register select bits, three DAC address bits, and 16 data bits as shown in Table 9. The timing diagram for this operation is shown in Figure 2.

At power-up, the DAC registers are loaded with zero code (0x0000), and the outputs are clamped to 0 V via a low impedance path. The outputs can be updated with the zero code value at this time by asserting either  $\overline{LDAC}$  or  $\overline{CLR}$ . The corresponding output voltage depends on the state of the BIN/2sCOMP pin. If the BIN/2sCOMP pin is tied to DGND, the data coding is twos complement, and the outputs update to 0 V. If the BIN/2sCOMP pin is tied to DV<sub>CC</sub>, the data coding is offset binary, and the outputs update to negative full scale. To have the outputs power up with zero code loaded to the outputs, the  $\overline{CLR}$  pin should be held low during power-up.

#### Standalone Operation

The serial interface works with both a continuous and noncontinuous serial clock. A continuous SCLK source can be used only if SYNC is held low for the correct number of clock cycles. In gated clock mode, a burst clock containing the exact number of clock cycles must be used, and SYNC must be taken high after the final clock to latch the data. The first falling edge of  $\overline{SYNC}$  starts the write cycle. Exactly 24 falling clock edges must be applied to SCLK before  $\overline{SYNC}$  is brought high again. If  $\overline{SYNC}$  is brought high before the 24<sup>th</sup> falling SCLK edge, the data written is invalid. If more than 24 falling SCLK edges are applied before  $\overline{SYNC}$  is brought high, the input data is also invalid. The input register addressed is updated on the rising edge of  $\overline{SYNC}$ . In order for another serial transfer to take place,  $\overline{SYNC}$  must be brought low again. After the end of the serial data transfer, data is automatically transferred from the input shift register to the addressed register.

When the data has been transferred into the chosen register of the addressed DAC, all DAC registers and outputs can be updated by taking  $\overline{LDAC}$  low.

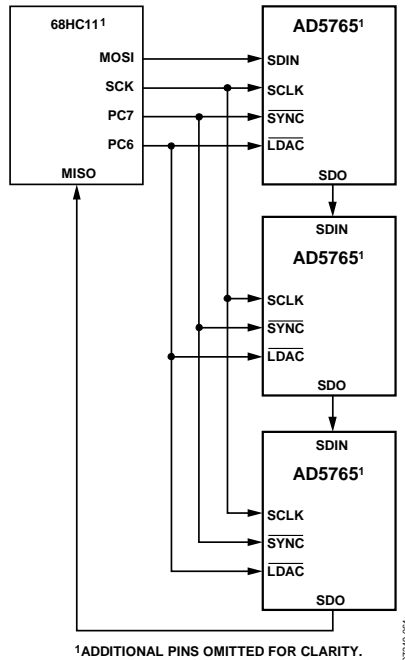

Figure 26. Daisy-Chaining the AD5765

### Daisy-Chain Operation

For systems that contain several devices, the SDO pin can be used to daisy-chain several devices together. This daisy-chain mode can be useful in system diagnostics and in reducing the number of serial interface lines. The first falling edge of SYNC starts the write cycle. The SCLK is continuously applied to the input shift register when SYNC is low. If more than 24 clock pulses are applied, the data ripples out of the shift register and appears on the SDO line. This data is clocked out on the rising edge of SCLK and is valid on the falling edge. By connecting the SDO of the first device to the SDIN input of the next device in the chain, a multidevice interface is constructed. Each device in the system requires 24 clock pulses. Therefore, the total number of clock cycles must equal 24 N, where N is the total number of AD5765 devices in the chain. When the serial transfer to all devices is complete, SYNC is taken high. This latches the input data in each device in the daisy chain and prevents additional data from being clocked into the input shift register. The serial clock can be a continuous or a gated clock.

A continuous SCLK source can be used only if SYNC is held low for the correct number of clock cycles. In gated clock mode, a burst clock containing the exact number of clock cycles must be used, and SYNC must be taken high after the final clock to latch the data.

### Readback Operation

Before a readback operation is initiated, the SDO pin must be enabled by writing to the function register and clearing the SDO disable bit; this bit is cleared by default. Readback mode is invoked by setting the R/W bit to 1 in the serial input register write. With R/W = 1, Bit A2 to Bit A0, in association with Bit REG2, Bit REG1, and Bit REG0, select the register to be read.

The remaining data bits in the write sequence are don't care. During the next SPI write, the data appearing on the SDO output is the data from the previously addressed register. For a read of a single register, the NOP command can be used in clocking out the data from the selected register on SDO. The readback diagram in Figure 4 shows the readback sequence. For example, to read back the fine gain register of Channel A on the AD5765, implement the following sequence:

1. Write 0xA0XXXX to the AD5765 input register. This configures the AD5765 for read mode with the fine gain register of Channel A selected. Note that all the data bits, DB15 to DB0, are don't cares.
2. Follow this with a second write, an NOP condition, 0x00XXXX. During this write, the data from the fine gain register is clocked out on the SDO line; that is, data clocked out contains the data from the fine gain register in Bit DB5 to Bit DB0.

### SIMULTANEOUS UPDATING VIA LDAC

Depending on the status of both SYNC and LDAC, and after data has been transferred into the input register of the DACs, there are two ways in which the DAC registers and DAC outputs can be updated: individually and simultaneously

#### Individual DAC Updating

In this mode, LDAC is held low while data is clocked into the input shift register. The addressed DAC output is updated on the rising edge of SYNC.

#### Simultaneous Updating of All DACs

In this mode, LDAC is held high while data is clocked into the input shift register. All DAC outputs are updated by taking LDAC low any time after SYNC has been taken high. The update now occurs on the falling edge of LDAC.

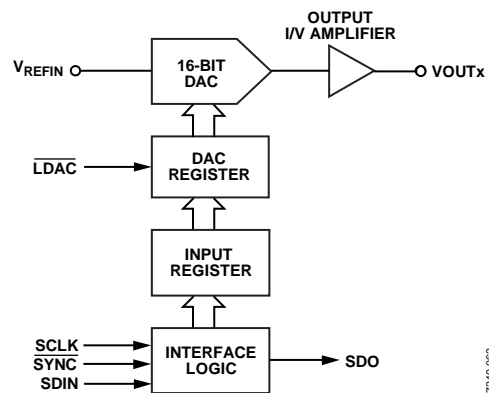

Figure 27. Simplified Serial Interface of Input Loading Circuitry for One DAC Channel

**TRANSFER FUNCTION**

Table 8 shows the ideal input-code-to-output-voltage relationship for the AD5765 for both offset binary and twos complement data coding.

**Table 8. Ideal Output Voltage to Input Code Relationship**

Digital Input				Analog Output
Offset Binary Data Coding				
MSB		LSB		VOUTx
1111	1111	1111	1111	$2 V_{REF} \times (32,767/32,768)$
1000	0000	0000	0001	$2 V_{REF} \times (1/32,768)$
1000	0000	0000	0000	0 V
0111	1111	1111	1111	$-2 V_{REF} \times (1/32,768)$
0000	0000	0000	0000	$-2 V_{REF} \times (32,767/32,768)$
Twos Complement Data Coding				
MSB		LSB		VOUTx
0111	1111	1111	1111	$2 V_{REF} \times (32,767/32,768)$
0000	0000	0000	0001	$2 V_{REF} \times (1/32,768)$
0000	0000	0000	0000	0 V
1111	1111	1111	1111	$-2 V_{REF} \times (1/32,768)$
1000	0000	0000	0000	$-2 V_{REF} \times (32,767/32,768)$

**Table 9. AD5765 Input Register Format**

MSB								LSB
DB23	DB22	DB21	DB20	DB19	DB18	DB17	DB16	DB15:DB0
R/W	0	REG2	REG1	REG0	A2	A1	A0	Data

**Table 10. Input Register Bit Functions**

Bit	Description																								
R/W	Indicates a read from or a write to the addressed register																								
REG2, REG1, REG0	Used in association with the address bits to determine if a read or write operation is to the data register, offset register, gain register, or function register																								
	<table border="1"> <thead> <tr> <th>REG2</th> <th>REG1</th> <th>REG0</th> <th>Function</th> </tr> </thead> <tbody> <tr> <td>0</td> <td>0</td> <td>0</td> <td>Function register</td> </tr> <tr> <td>0</td> <td>1</td> <td>0</td> <td>Data register</td> </tr> <tr> <td>0</td> <td>1</td> <td>1</td> <td>Coarse gain register</td> </tr> <tr> <td>1</td> <td>0</td> <td>0</td> <td>Fine gain register</td> </tr> <tr> <td>1</td> <td>0</td> <td>1</td> <td>Offset register</td> </tr> </tbody> </table>	REG2	REG1	REG0	Function	0	0	0	Function register	0	1	0	Data register	0	1	1	Coarse gain register	1	0	0	Fine gain register	1	0	1	Offset register
REG2	REG1	REG0	Function																						
0	0	0	Function register																						
0	1	0	Data register																						
0	1	1	Coarse gain register																						
1	0	0	Fine gain register																						
1	0	1	Offset register																						
A2, A1, A0	Used to decode the DAC channels																								
	<table border="1"> <thead> <tr> <th>A2</th> <th>A1</th> <th>A0</th> <th>Channel Address</th> </tr> </thead> <tbody> <tr> <td>0</td> <td>0</td> <td>0</td> <td>DAC A</td> </tr> <tr> <td>0</td> <td>0</td> <td>1</td> <td>DAC B</td> </tr> <tr> <td>0</td> <td>1</td> <td>0</td> <td>DAC C</td> </tr> <tr> <td>0</td> <td>1</td> <td>1</td> <td>DAC D</td> </tr> <tr> <td>1</td> <td>0</td> <td>0</td> <td>All DACs</td> </tr> </tbody> </table>	A2	A1	A0	Channel Address	0	0	0	DAC A	0	0	1	DAC B	0	1	0	DAC C	0	1	1	DAC D	1	0	0	All DACs
A2	A1	A0	Channel Address																						
0	0	0	DAC A																						
0	0	1	DAC B																						
0	1	0	DAC C																						
0	1	1	DAC D																						
1	0	0	All DACs																						
D15:D0	Data bits																								

The output voltage expression for the AD5765 is given by

$$V_{OUT} = -2 \times V_{REFIN} + 4 \times V_{REFIN} \left[ \frac{D}{65,536} \right]$$

where:

D is the decimal equivalent of the code loaded to the DAC.

$V_{REFIN}$  is the reference voltage applied at the REFAB and REFCD pins.

**ASYNCHRONOUS CLEAR (CLR)**

CLR is a negative edge triggered clear that allows the outputs to be cleared to either 0 V (twos complement coding) or negative full scale (offset binary coding). It is necessary to maintain CLR low for a minimum amount of time (see Figure 2) for the operation to complete. When the CLR signal is returned high, the output remains at the cleared value until a new value is programmed. If, at power-on, CLR is at 0 V, then all DAC outputs are updated with the clear value. A clear can also be initiated through software by writing the command 0x04XXXX to the AD5765.

## FUNCTION REGISTER

The function register is addressed by setting the three REG bits to 000. The values written to the address bits and the data bits determine the function addressed. The functions available via the function register are outlined in Table 11 and Table 12.

**Table 11. Function Register Options**

REG2	REG1	REG0	A2	A1	A0	DB15:DB6	DB5	DB4	DB3	DB2	DB1	DB0
0	0	0	0	0	0	No operation, data = don't care						
0	0	0	0	0	1	Don't care	Local ground offset adjustment	D1 direction	D1 value	D0 direction	D0 value	SDO disable
0	0	0	1	0	0	Clear, data = don't care						
0	0	0	1	0	1	Load, data = don't care						

**Table 12. Explanation of Function Register Options**

Option	Description
NOP	No operation instruction used in readback operations.
Local Ground Offset Adjustment	Set by the user to enable the local ground offset adjustment function. Cleared by the user to disable the local ground offset adjustment function (default). See the Design Features section for additional details.
D0/D1 Direction	Set by the user to enable D0/D1 as outputs. Cleared by the user to enable D0/D1 as inputs (default). See the Design Features section for additional details.
D0/D1 Value	I/O port status bits. Logic values written to these locations determine the logic outputs on the D0 and D1 pins when configured as outputs. These bits indicate the status of the D0 and D1 pins when the I/O port is active as an input. When enabled as inputs, these bits are don't cares during a write operation.
SDO Disable	Set by the user to disable the SDO output. Cleared by the user to enable the SDO output (default).
Clear	Addressing this function resets the DAC outputs to 0 V in twos complement mode and negative full scale in binary mode.
Load	Addressing this function updates the DAC registers and, consequently, the analog outputs.

## DATA REGISTER

The data register is addressed by setting the three REG bits to 010. The DAC address bits select the DAC channel with which the data transfer is to take place (see Table 10). The data bits are in the DB15 to DB0 positions, as shown in Table 13.

**Table 13. Programming the AD5765 Data Register**

REG2	REG1	REG0	A2	A1	A0	DB15:DB0
0	1	0	DAC address			16-bit DAC data

## COARSE GAIN REGISTER

The coarse gain register is addressed by setting the three REG bits to 011. The DAC address bits select the DAC channel with which the data transfer is to take place (see Table 10). The coarse gain register is a 2-bit register and allows the user to select the output range of each DAC, as shown in Table 14 and Table 15.

**Table 14. Programming the AD5765 Coarse Gain Register**

REG2	REG1	REG0	A2	A1	A0	DB15:DB2	DB1	DB0
0	1	1	DAC address			Don't care	CG1	CG0

**Table 15. Output Range Selection**

Output Range	CG1	CG0
±4.096 V (default)	0	0
±4.20103 V	0	1
±4.31158 V	1	0

## FINE GAIN REGISTER

The fine gain register is addressed by setting the three REG bits to 100. The DAC address bits select the DAC channel with which the data transfer is to take place (see Table 10). The fine gain register is a 6-bit register and allows the user to adjust the gain of each DAC channel by  $-32$  LSBs to  $+31$  LSBs in 1 LSB increments as shown in Table 16 and Table 17. The adjustment is made to both the positive full-scale and negative full-scale points simultaneously, each point being adjusted by  $\frac{1}{2}$  of one step. The fine gain register coding is twos complement.

**Table 16. Programming AD5765 Fine Gain Register**

REG2	REG1	REG0	A2	A1	A0	DB15:DB6	DB5	DB4	DB3	DB2	DB1	DB0
1	0	0	DAC address			Don't care	FG5	FG4	FG3	FG2	FG1	FG0

**Table 17. AD5765 Fine Gain Register Options**

Gain Adjustment	FG5	FG4	FG3	FG2	FG1	FG0
+31 LSBs	0	1	1	1	1	1
+30 LSBs	0	1	1	1	1	0
...	...	...	...	...	...	...
No Adjustment (Default)	0	0	0	0	0	0
...	...	...	...	...	...	...
-31 LSBs	1	0	0	0	0	1
-32 LSBs	1	0	0	0	0	0

## OFFSET REGISTER

The offset register is addressed by setting the three REG bits to 101. The DAC address bits select the DAC channel with which the data transfer is to take place (see Table 10). The AD5765 offset register is an 8-bit register and allows the user to adjust the offset of each channel by  $-16$  LSBs to  $+15.875$  LSBs in increments of  $\frac{1}{8}$  LSB as shown in Table 18 and Table 19. The offset register coding is twos complement.

**Table 18. Programming the AD5765 Offset Register**

REG2	REG1	REG0	A2	A1	A0	DB15:DB8	DB7	DB6	DB5	DB4	DB3	DB2	DB1	DB0
1	0	1	DAC address			Don't care	OF7	OF6	OF5	OF4	OF3	OF2	OF1	OF0

**Table 19. AD5765 Offset Register Options**

Offset Adjustment	OF7	OF6	OF5	OF4	OF3	OF2	OF1	OF0
+15.875 LSBs	0	1	1	1	1	1	1	1
+15.75 LSBs	0	1	1	1	1	1	1	0
...	...	...	...	...	...	...	...	...
No Adjustment (Default)	0	0	0	0	0	0	0	0
...	...	...	...	...	...	...	...	...
-15.875 LSBs	1	0	0	0	0	0	0	1
-16 LSBs	1	0	0	0	0	0	0	0

## OFFSET AND GAIN ADJUSTMENT WORKED EXAMPLE

Using the information provided in the Theory of Operation section, the following worked example demonstrates how the AD5765 functions can be used to eliminate both offset and gain errors. Because the AD5765 is factory calibrated, offset and gain errors should be negligible. However, errors can be introduced by the system that the AD5765 is operating within; for example, a voltage reference value that is not equal to 2.048 V introduces a gain error. An output range of  $\pm 4.096$  V and twos complement data coding are assumed.

### Removing Offset Error

The AD5765 can eliminate an offset error in the range of  $-2$  mV to  $+1.98$  mV with a step size of  $\frac{1}{8}$  of a 16-bit LSB.

1. Calculate the step size of the offset adjustment.

$$\text{Offset Adjust Step Size} = \frac{8.192}{2^{16} \times 8} = 15.625 \mu\text{V}$$

2. Measure the offset error by programming 0x0000 to the data register and measuring the resulting output voltage; for this example, the measured value is 614  $\mu\text{V}$ .
3. Calculate the number of offset adjustment steps that this value represents.

$$\text{Number of Steps} = \frac{\text{Measured Offset Value}}{\text{Offset Step Size}} = \frac{614 \mu\text{V}}{15.625 \mu\text{V}} = 13 \text{ Steps}$$

The offset error measured is positive; therefore, a negative adjustment of 40 steps is required. The offset register is 8-bits wide and the coding is twos complement.

The required offset register value can be calculated as follows:

1. Convert the adjustment value to binary: 00101000.

2. Convert the binary number to a negative twos complement number by inverting all bits and adding 1: 11011000.

11011000 is the value that should be programmed to the offset register.

Note that this twos complement conversion is not necessary in the case of a positive offset adjustment. The value to be programmed to the offset register is simply the binary representation of the adjustment value.

### Removing Gain Error

The AD5765 can eliminate a gain error at negative full-scale output in the range of  $-2$  mV to  $+1.94$  mV with a step size of  $\frac{1}{2}$  of a 16-bit LSB.

1. Calculate the step size of the gain adjustment.

$$\text{Gain Adjust Step Size} = \frac{8.192}{2^{16} \times 2} = 62.5 \mu\text{V}$$

2. Measure the gain error by programming 0x8000 to the data register and measuring the resulting output voltage. The gain error is the difference between this value and  $-4.096$  V; for this example, the gain error is  $-0.8$  mV.
3. Calculate how many gain adjustment steps this value represents.

$$\text{Number of Steps} = \frac{\text{Measured Gain Value}}{\text{Gain Step Size}} = \frac{0.8 \text{ mV}}{62.5 \mu\text{V}} = 13 \text{ Steps}$$

The gain error measured is negative (in terms of magnitude); therefore, a positive adjustment of 13 steps is required. The gain register is six bits wide and the coding is twos complement.

The required gain register value can be determined as follows:

1. Convert the adjustment value to binary: 001101.

The value to be programmed to the gain register is simply this binary number.

## DESIGN FEATURES

### ANALOG OUTPUT CONTROL

In many industrial process control applications, it is vital that the output voltage be controlled during power-up and during brownout conditions. When the supply voltages are changing, the output pins are clamped to 0 V via a low impedance path. To prevent the output amp being shorted to 0 V during this time, transmission gate G1 is also opened (see Figure 28). These conditions are maintained until the power supplies stabilize and a valid word is written to the DAC register. At this time, G2 opens and G1 closes.

Both transmission gates are also externally controllable via the reset logic ( $\overline{\text{RSTIN}}$ ) control input. For instance, if  $\overline{\text{RSTIN}}$  is driven from a battery supervisor chip, the  $\overline{\text{RSTIN}}$  input is driven low to open G1 and close G2 on power-down or during a brownout. Conversely, the on-chip voltage detector output ( $\overline{\text{RSTOUT}}$ ) is also available to the user to control other parts of the system. The basic transmission gate functionality is shown in Figure 28.

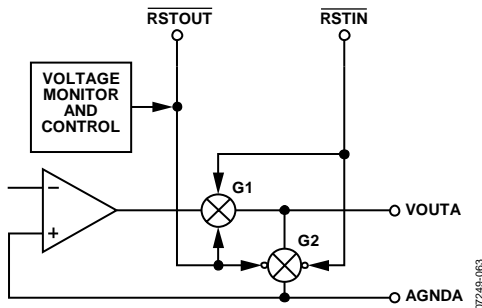

Figure 28. Analog Output Control Circuitry

### DIGITAL OFFSET AND GAIN CONTROL

The AD5765 incorporates a digital offset adjustment function with a  $\pm 16$  LSB adjustment range and 0.125 LSB resolution. The gain register allows the user to adjust the AD5765 full-scale output range. The full-scale output can be programmed to achieve full-scale ranges of  $\pm 4.096$  V,  $\pm 4.201$  V, and  $\pm 4.311$  V. A fine gain trim is also provided.

### PROGRAMMABLE SHORT-CIRCUIT PROTECTION

The short-circuit current of the output amplifiers can be programmed by inserting an external resistor between the ISCC pin and PGND. The programmable range for the current is 500  $\mu\text{A}$  to 10 mA, corresponding to a resistor range of 120 k $\Omega$  to 6 k $\Omega$ . The resistor value is calculated as follows:

$$R \approx \frac{60}{I_{sc}}$$

If the ISCC pin is left unconnected, the short-circuit current limit defaults to 5 mA. It should be noted that limiting the short-circuit current to a small value can affect the slew rate of the output when driving into a capacitive load; therefore, the value of the short-circuit current programmed should take into account the size of the capacitive load being driven.

### DIGITAL I/O PORT

The AD5765 contains a 2-bit digital I/O port (D1 and D0). These bits can be configured as inputs or outputs independently and can be driven or have their values read back via the serial interface. The I/O port signals are referenced to  $\text{DV}_{CC}$  and  $\text{DGND}$ . When configured as outputs, they can be used as control signals to multiplexers or can be used to control calibration circuitry elsewhere in the system. When configured as inputs, the logic signals from limit switches, for example, can be applied to D0 and D1 and can be read back via the digital interface.

### DIE TEMPERATURE SENSOR

The on-chip die temperature sensor provides a voltage output that is linearly proportional to the centigrade temperature scale. Its nominal output voltage is 1.44 V at  $+25^{\circ}\text{C}$  die temperature, varying at 3 mV/ $^{\circ}\text{C}$  and resulting in a typical output range of 1.175 V to 1.9 V over the full temperature range. Its low output impedance and linear output simplify interfacing to temperature control circuitry and ADCs. The temperature sensor is provided as more of a convenience than a precise feature; it is intended to indicate a die temperature change for recalibration purposes.

### LOCAL-GROUND-OFFSET ADJUSTMENT

The AD5765 incorporates a local-ground-offset adjustment feature that, when enabled in the function register, adjusts the DAC outputs for voltage differences between the individual DAC ground pins and the REFGND pin, ensuring that the DAC output voltages are always referenced with respect to the local DAC ground pin. For instance, if Pin AGNDA is at +5 mV with respect to the REFGND pin and VOUTA is measured with respect to AGNDA, a  $-5$  mV error results, enabling the local-ground-offset adjustment feature to adjust VOUTA by +5 mV, thereby eliminating the error.

## POWER-ON STATUS

The AD5765 has multiple power supply and digital input pins. It is important to consider the sequence in which the pins are powered up to ensure that the AD5765 powers on in the required state. The outputs power on either clamped to AGNDx, driving 0 V, or driving negative full-scale output (−4.096 V), depending on how the BIN/2sCOMP, CLR, and LDAC pins are configured during power-up.

The CLR pin, if connected to DGND, causes the DAC registers to be loaded with 0x0000 and the outputs to be updated; consequently, the outputs are loaded with 0 V if BIN/2sCOMP is connected to DGND or with negative full-scale (−4.096 V) if BIN/2sCOMP is connected to DVCC, corresponding respectively to the two's complement and binary voltages for the digital code 0x0000. During power-up, the state of the LDAC pin has an identical effect to that of the CLR pin. If both the CLR and

LDAC pins are connected to DVCC during power-up, the outputs power on clamped to AGNDx and remain so until a valid write is made to the device. Table 20 outlines the possible output power-on states.

**Table 20. Output Power-On States**

BIN/2sCOMP	CLR	LDAC	V <sub>OUT</sub> at Power-On
DGND	DGND	DGND	0 V
DGND	DGND	DV <sub>CC</sub>	0 V
DGND	DV <sub>CC</sub>	DGND	0 V
DGND	DV <sub>CC</sub>	DV <sub>CC</sub>	Clamped to AGNDx
DV <sub>CC</sub>	DGND	DGND	−4.096 V
DV <sub>CC</sub>	DGND	DV <sub>CC</sub>	−4.096 V
DV <sub>CC</sub>	DV <sub>CC</sub>	DGND	−4.096 V
DV <sub>CC</sub>	DV <sub>CC</sub>	DV <sub>CC</sub>	Clamped to AGNDx





## LAYOUT GUIDELINES

For any circuit in which accuracy is important, careful consideration of the power supply and ground return layout helps to ensure the rated performance. The printed circuit board on which the AD5765 is mounted should be designed so that the analog and digital sections are separated and confined to certain areas of the board. If the AD5765 is in a system in which multiple devices require an AGND-to-DGND connection, the connection should be made at one point only. The star ground point should be established as close as possible to the device. The AD5765 should have ample supply bypassing of 10  $\mu\text{F}$  in parallel with 0.1  $\mu\text{F}$  on each supply located as close to the package as possible, ideally right up against the device. The 10  $\mu\text{F}$  capacitors are the tantalum bead type. The 0.1  $\mu\text{F}$  capacitor should have low effective series resistance (ESR) and low effective series inductance (ESI) such as the common ceramic types, which provide a low impedance path to ground at high frequencies to handle transient currents due to internal logic switching.

The power supply lines of the AD5765 should use as large a trace as possible to provide low impedance paths and reduce the effects of glitches on the power supply line. Fast switching signals, such as clocks, should be shielded with digital ground to avoid radiating noise to other parts of the board and should never be run near the reference inputs. A ground line routed between the SDIN and SCLK lines helps reduce crosstalk between them (this is not required on a multilayer board, which has a separate ground plane; however, it is helpful to separate the lines). It is essential to minimize noise on the reference inputs because such noise couples through to the DAC output. Avoid crossover of digital and analog signals. Traces on opposite sides of the board should run at right angles to each other. This reduces the effects of feedthrough on the board. A microstrip technique is recommended but not always possible with a double-sided board. In this technique, the component side of the board is dedicated to the ground plane, and signal traces are placed on the solder side.

## GALVANICALLY ISOLATED INTERFACE

In many process control applications, it is necessary to provide an isolation barrier between the controller and the unit being controlled to protect and isolate the controlling circuitry from any hazardous common-mode voltages that may occur. Isocouplers provide voltage isolation in excess of 2.5 kV. The serial loading structure of the AD5765 makes it ideal for

isolated interfaces because the number of interface lines is kept to a minimum. Figure 30 shows a 4-channel isolated interface to the AD5765 using an ADuM1400. For more information, go to [www.analog.com](http://www.analog.com).

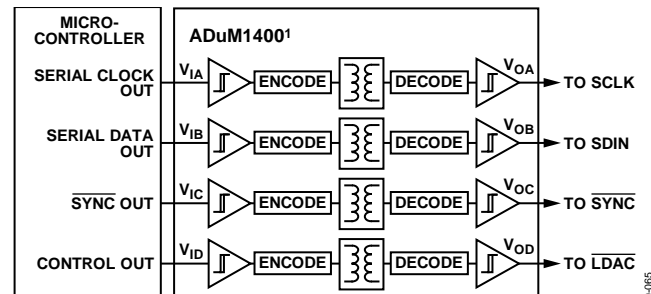

<sup>1</sup>ADDITIONAL PINS OMITTED FOR CLARITY.

Figure 30. Isolated Interface

## MICROPROCESSOR INTERFACING

Microprocessor interfacing to the AD5765 is via a serial bus that uses a standard protocol that is compatible with microcontrollers and DSP processors. The communications channel is a 3-wire (minimum) interface consisting of a clock signal, a data signal, and a synchronization signal. The AD5765 requires a 24-bit data-word with data valid on the falling edge of SCLK.

For all the interfaces, the DAC output update can be done automatically when all the data is clocked in, or it can be done under the control of LDAC. The contents of the DAC register can be read using the readback function.

### AD5765 to Blackfin DSP Interface

Figure 31 shows how the AD5765 can be interfaced to an Analog Devices, Inc., Blackfin<sup>®</sup> DSP. The Blackfin has an integrated SPI port that can be connected directly to the SPI pins of the AD5765 and programmable I/O pins that can be used to set the state of a digital input such as the LDAC pin.

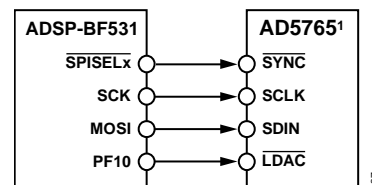

<sup>1</sup>ADDITIONAL PINS OMITTED FOR CLARITY.

Figure 31. AD5765 to Blackfin Interface

# OUTLINE DIMENSIONS

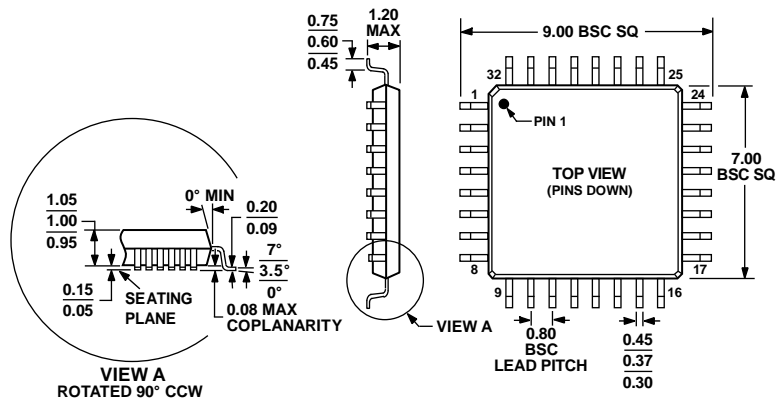

COMPLIANT TO JEDEC STANDARDS MS-026-ABA

Figure 32. 32-Lead Thin Plastic Quad Flat Package [TQFP] (SU-32-2)

Dimensions shown in millimeters

020607-A

## ORDERING GUIDE

Model <sup>1</sup>	INL	Temperature Range	Package Description	Package Option
AD5765BSUZ	± 2 LSB	-40°C to +105°C	32-Lead TQFP	SU-32-2
AD5765BSUZ-REEL7	± 2 LSB	-40°C to +105°C	32-Lead TQFP	SU-32-2
AD5765CSUZ	± 1 LSB	-40°C to +105°C	32-Lead TQFP	SU-32-2
AD5765CSUZ-REEL7	± 1 LSB	-40°C to +105°C	32-Lead TQFP	SU-32-2
EVAL-AD5765EBZ			Evaluation Board	

<sup>1</sup> Z = RoHS Compliant Part.

**NOTES**



Компания «ЭлектроПласт» предлагает заключение долгосрочных отношений при поставках импортных электронных компонентов на взаимовыгодных условиях!

Наши преимущества:

- Оперативные поставки широкого спектра электронных компонентов отечественного и импортного производства напрямую от производителей и с крупнейших мировых складов;
- Поставка более 17-ти миллионов наименований электронных компонентов;
- Поставка сложных, дефицитных, либо снятых с производства позиций;
- Оперативные сроки поставки под заказ (от 5 рабочих дней);
- Экспресс доставка в любую точку России;
- Техническая поддержка проекта, помощь в подборе аналогов, поставка прототипов;
- Система менеджмента качества сертифицирована по Международному стандарту ISO 9001;
- Лицензия ФСБ на осуществление работ с использованием сведений, составляющих государственную тайну;
- Поставка специализированных компонентов (Xilinx, Altera, Analog Devices, Intersil, Interpoint, Microsemi, Aeroflex, Peregrine, Syfer, Eurofarad, Texas Instrument, Miteq, Cobham, E2V, MA-COM, Hittite, Mini-Circuits, General Dynamics и др.);

Помимо этого, одним из направлений компании «ЭлектроПласт» является направление «Источники питания». Мы предлагаем Вам помощь Конструкторского отдела:

- Подбор оптимального решения, техническое обоснование при выборе компонента;
- Подбор аналогов;
- Консультации по применению компонента;
- Поставка образцов и прототипов;
- Техническая поддержка проекта;
- Защита от снятия компонента с производства.



#### Как с нами связаться

**Телефон:** 8 (812) 309 58 32 (многоканальный)

**Факс:** 8 (812) 320-02-42

**Электронная почта:** [org@eplast1.ru](mailto:org@eplast1.ru)

**Адрес:** 198099, г. Санкт-Петербург, ул. Калинина, дом 2, корпус 4, литера А.