

Manual Switches

Solid State LED Annunciators

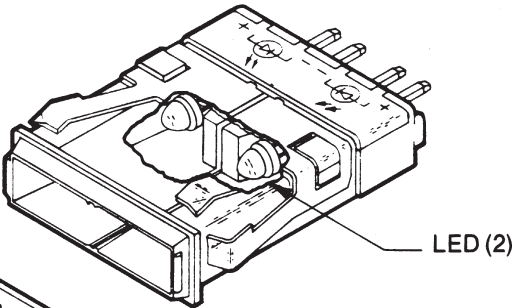

AML45 Housing



AML59 Cap Assembly

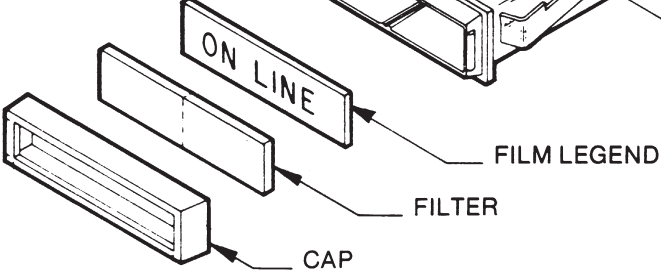

AML45/59 solid state LED annunciators are a state-of-the-art advancement over traditional back-lighted legend displays which utilize incandescent lamps. The LED light source imparts the benefits of solid state long-life and reliability, with low power requirements. Operating life is measured by years, instead of hours.

The AML45 housing has two high efficiency LED's which illuminate color filters and film legends located in the snap-on AML59 cap assembly. There is a choice of full face one-color and split one-color or two-color displays. Color options are red, green, and yellow.

Film legends offer a choice of negative or positive formats. (Note: human factors engineers generally favor negative annunciator messages, reserving the positive format for use if special attention is necessary, such as "PAPER JAM.")

When unlighted, the legend is hidden (dead front).

FEATURES

- Messages are backlighted with LED's for long, reliable operating life. Reduces service and maintenance costs.
- Low voltage and current (without inrush), enables direct drive with integrated circuits. Reduces cost of interface components (and installation), and power supply.
- Low operating temperature allows high-density, continuous operation. Minimal heat build-up.
- Inherently rugged. Resists effects of shock and vibration (no filaments to break).
- High density message display. Illuminates up to four legend sectors in color, in a 0.8 x 1.2 inch area.
- Dead front hides legends until illuminated. Non-glare display with no flickering.
- UL recognized.

NEGATIVE

When illuminated, colored legend appears against a black background.



POSITIVE

When illuminated, black legend appears against a colored background.



This annunciator is totally compatible with other devices in the MICRO SWITCH AML Advanced Manual Line both in front of, and behind the panel. Two of them fit in the same space as a rectangular AML indicators or switch. All terminals exit at AML's standard 1.7-inch depth for convenient, single-level wiring.

Manuals

Manual Switches

Solid State LED Annunciators

AML45 LED HOUSINGS

LEDs should be specified as the same color if a full or split screen one-color display is desired (RR = red); or different colors for a split screen two-color display (RY = red/yellow). (Baffle plate inside housing prevents light spillage from one LED color section to the other on split screen versions.)

LED colors should match filter colors specified in AML59 cap assembly (see page 40).

Spring clips on sides of the housing hold units securely in panel. For mounting strips of two or more units, AML61 mounting hardware may be used (see page 55).

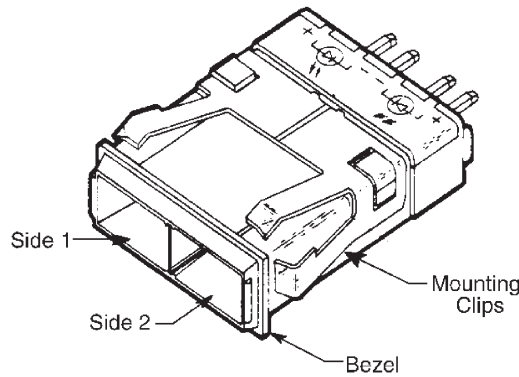

LED APPLICATION INFORMATION

Refer to page 59.

PANEL ORIENTATION

Drawing (above) indicates Side 1 and Side 2 LED locations, with MICRO SWITCH identifications facing UP. Consider this orientation when ordering an **AML45S** housing with two different LED

colors, such as RG (red/Side 1, green/Side 2). Since LED's are permanently installed, color location is specially important to note when the device is to be terminated in a printed circuit board.

AML45 ORDER GUIDE

AML45 S	W	A	2	RY	
				Side 1	Side 2
Housing Type	Color of Housing Bezel	LED Voltage*	Terminal Type		
AML45 R 2 LED's (For use with Full Screen)	W White	A 2.4 V	2 .110 × .020 (Solder or Quick-Connect)	R Red	R Red
AML45 S 2 LED's (For use with Split Screen)	K Black	B 5 V	3 .025 × .025 (Printed Circuit)	Y Yellow	Y Yellow
		C 10 V	8 .110 × .020 with diode protection for LED's	G Green	G Green
		D 15 V			
		F 24 V			

* Current draw is 20 mA. "B", "C", "D" and "F" have built-in current limiting resistors.

Example: **AML45SWA2RY**

Split screen type housing with white bezel, 2.4 V LED's, .110 × .020 termination, red LED in Side 1 and yellow LED in Side 2.

Manual Switches

Solid State Annunciators

SUBPANEL MOUNTING



Order AML45/59 annunciators and AML61 mounting hardware separately.

AML61 mounting hardware may be used for mounting strips of two or more annunciators in pairs in a single cutout. This method is most cost-effective for multi-unit application, since it generally takes less time to make one large hole to accept several units than it does to make a hole for each individual unit. Also, if the front panel is not required for mounting support, it can be made thinner, and easier to cut out, minimizing installed cost.

AML61 strips are factory assembled with metal cans welded together, and mounting brackets welded to the end cans. Refer to page 45 for ordering information.

INSTALLATION

Each rectangular AML61 mounting can will accommodate two annunciators, as shown in the drawing. Panel appearance is enhanced if a spacer .05 in./1.3 mm thick (approx.) is installed between the housings at the terminal end. Specify Catalog Listing 30PA1-AML for a package of 10 spacers.

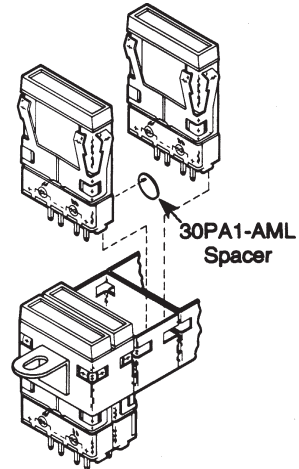

Mounting centers and panel cutout dimensions are shown on page 64. An installation instruction sheet PK8520 is shipped with each order.

PRINTED CIRCUIT BOARD DIMENSIONS

Suggested printed circuit board layout for up to ten AML45 units assembled in an AML61 assembly:

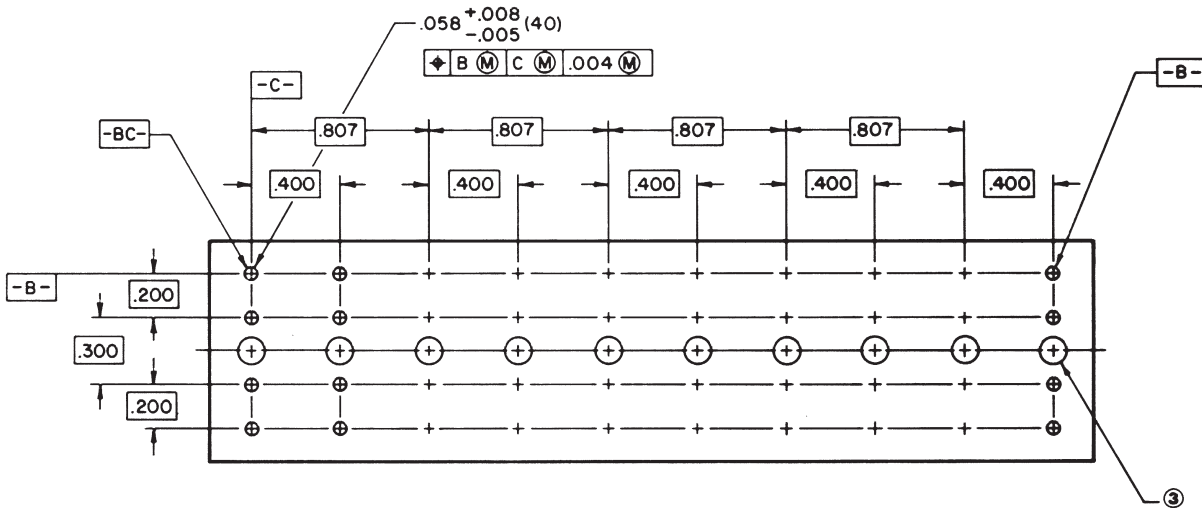

© .125" minimum diameter hole recommended to permit access to annunciator, allowing it to be driven out panel front should replacement become necessary.

Manuals

Maual Switches

Solid State LED Annunciators

AML59 CAP ASSEMBLIES

The cap assembly consists of: black cap, color filter(s), and optional film legend; furnished unassembled. It snaps onto housing, flush with the housing bezel.

Filters, assembled with their matte finish facing the LED's, efficiently diffuse the illumination. They are color-tinted to complement the red, yellow, and green LED's.

NOTE: Cap assembly should not be subjected to the temperature and chemical atmosphere associated with wave soldering. These parts should be installed after soldering and cleanup.



Catalog listings for AML59 cap assemblies are derived from the ordering guide below. The ordering guide for AML45 LED housings is on page 38.

CUSTOM LEGENDS

A 2:1 drawing in black ink is required for satisfactory reproduction of custom film legends. As an alternative, you may submit an office copy of a page from a typographic supplier catalog such as Charpak, Letraset, and Zipatone. MICRO SWITCH can also furnish graphic legends from the "Henry Dreyfus Symbol Source Book." (Custom legends require a one-time start-up charge.)

- ① Viewing area inside cap:
X = 1.04 min.; Y = .272 min.
- ② Customers ordering film legends from commercial photographic or typesetting sources should specify that the film be precision cut, per the following dimensions, to insure proper retention and alignment on the face of the annunciator: A = .007 max.; B = 1.1 ± .010; C = .300 ± .003.

STANDARD LEGENDS

AML59 Legend Sheet (see page 42) provides ordering information for negative and positive standard film legends in the type style (14-point Helvetica condensed bold) shown below. Use separate legend sheet for each AML59 catalog listing and attach it (them) to your purchase order.

ABCDEFGHIJKLMN OPQRST
UVWXYZ &?!(:) :',.-/#% 1/2
\$0123456789 ↓

Approx. .165" ↓

AML59 ORDER GUIDE

Cap Style		Cap Color	Legend Type	Filter Color		
AML59-R		K	10	Full Screen	Split Screen	
Full Screen		Black	No Legend	R Red	R Red	R Red
AML59-S			20 Negative Film Legend	Y Yellow	Y Yellow	Y Yellow
			21 Positive Film Legend	G Green	G Green	G Green

Examples:
AML59-RK10R
 Full screen style, black cap, no legend, and red filter.

AML59-SK20RY
 Split screen style, black cap, negative film legend, red and yellow color filters.

AML59 Legend Sheet

Account NO _____

Use this form to describe film legends to be used with AML59 Series Cover Assemblies

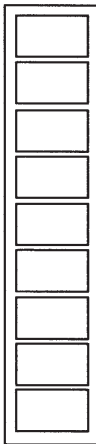
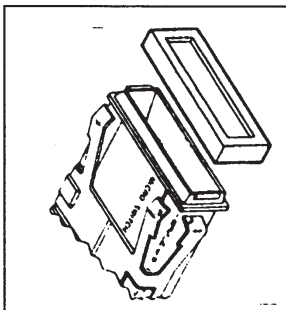

Style "R" (Full Screen)

Special Direction _____

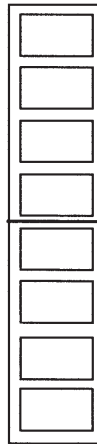
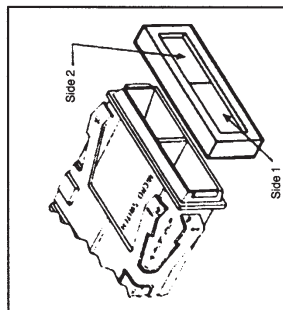

Style "S" (Split Screen)

Special Direction _____

Catalog Listing AML59 -	Quantity Ordered
P.O. No.	Line No
Schedule No.	Customer Part No.
	Customer Dwg. No.

Customer: _____
Address: _____ (city) _____ (state)

INSTRUCTIONS:

- Please use black ink to fill in shaded areas.
- Fill in appropriate catalog listing. - One listing per sheet.
- Fill in quantity ordered and your order no.
- Indicate legends desired - do not exceed 9 characters for style "R" or 4 characters on either side of style "S".
- This completed form must accompany your purchase order

NOTES:

- Legends must be designed to properly assemble to housings, which are to be installed with the MICRO SWITCH logo "up".
- All legends will be centered unless special directions are given.
- Standard legends are 14 pt. helvetica, condensed - Bold. A thru Z and numerals 0 thru 9 are standard.
- Legend Type:
 - Type "20" **NEGATIVE**
 - Type "21" **POSITIVE**



Компания «ЭлектроПласт» предлагает заключение долгосрочных отношений при поставках импортных электронных компонентов на взаимовыгодных условиях!

Наши преимущества:

- Оперативные поставки широкого спектра электронных компонентов отечественного и импортного производства напрямую от производителей и с крупнейших мировых складов;
- Поставка более 17-ти миллионов наименований электронных компонентов;
- Поставка сложных, дефицитных, либо снятых с производства позиций;
- Оперативные сроки поставки под заказ (от 5 рабочих дней);
- Экспресс доставка в любую точку России;
- Техническая поддержка проекта, помощь в подборе аналогов, поставка прототипов;
- Система менеджмента качества сертифицирована по Международному стандарту ISO 9001;
- Лицензия ФСБ на осуществление работ с использованием сведений, составляющих государственную тайну;
- Поставка специализированных компонентов (Xilinx, Altera, Analog Devices, Intersil, Interpoint, Microsemi, Aeroflex, Peregrine, Syfer, Eurofarad, Texas Instrument, Miteq, Cobham, E2V, MA-COM, Hittite, Mini-Circuits, General Dynamics и др.);

Помимо этого, одним из направлений компании «ЭлектроПласт» является направление «Источники питания». Мы предлагаем Вам помощь Конструкторского отдела:

- Подбор оптимального решения, техническое обоснование при выборе компонента;
- Подбор аналогов;
- Консультации по применению компонента;
- Поставка образцов и прототипов;
- Техническая поддержка проекта;
- Защита от снятия компонента с производства.



Как с нами связаться

Телефон: 8 (812) 309 58 32 (многоканальный)

Факс: 8 (812) 320-02-42

Электронная почта: org@eplast1.ru

Адрес: 198099, г. Санкт-Петербург, ул. Калинина, дом 2, корпус 4, литера А.