



# HD1750FX

## HIGH VOLTAGE NPN POWER TRANSISTOR FOR HIGH DEFINITION AND NEW SUPER-SLIM CRT DISPLAYS

- STATE-OF-THE-ART TECHNOLOGY: DIFFUSED COLLECTOR "ENHANCED GENERATION" EHVS1
- WIDER RANGE OF OPTIMUM DRIVE CONDITIONS
- LESS SENSITIVE TO OPERATING TEMPERATURE VARIATION
- FULLY INSULATED POWER PACKAGE U.L. COMPLIANT

### APPLICATIONS

- HORIZONTAL DEFLECTION OUTPUT FOR DIGITAL TV, HDTV AND HIGH-END MONITORS

### DESCRIPTION

The device is manufactured using Diffused Collector in Planar technology adopting "Enhance High Voltage Structure" (EHVS1) developed to fit High-Definition CRT displays.

The new HD product series show improved silicon efficiency bringing updated performance to the Horizontal Deflection stage.

Figure 1: Package

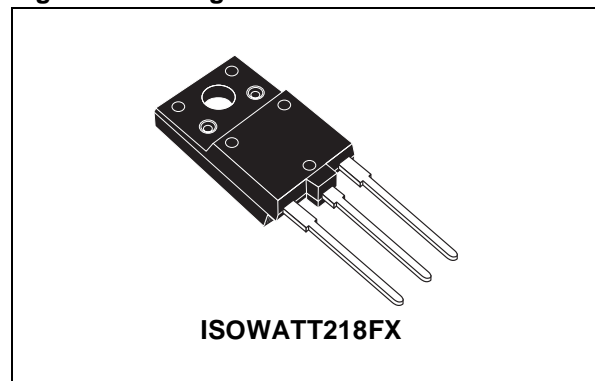

Figure 2: Internal Schematic Diagram

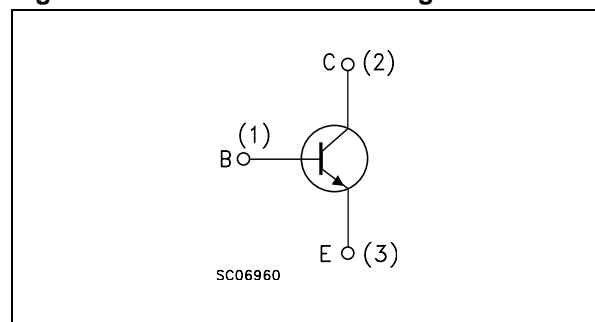

Table 1: Order Codes

Part Number	Marking	Package	Packaging
HD1750FX	HD1750FX	ISOWATT218FX	TUBE

## HD1750FX

**Table 2: Absolute Maximum Ratings**

Symbol	Parameter	Value	Unit
$V_{CES}$	Collector-Emitter Voltage ( $V_{BE} = 0$ )	1700	V
$V_{CEO}$	Collector-Emitter Voltage ( $I_B = 0$ )	800	V
$V_{EBO}$	Emitter-Base Voltage ( $I_C = 0$ )	10	V
$I_C$	Collector Current	24	A
$I_{CM}$	Collector Peak Current ( $t_p < 5\text{ms}$ )	36	A
$I_B$	Base Current	12	A
$I_{BM}$	Base Peak Current ( $t_p < 5\text{ms}$ )	18	A
$P_{tot}$	Total Dissipation at $T_C = 25\text{ }^\circ\text{C}$	75	W
$V_{ins}$	Insulation Withstand Voltage (RMS) from All Three Leads to External Heatsink	2500	V
$T_{stg}$	Storage Temperature	-65 to 150	$^\circ\text{C}$
$T_J$	Max. Operating Junction Temperature	150	$^\circ\text{C}$

**Table 3: Thermal Data**

$R_{thj-case}$	Thermal Resistance Junction-Case	Max	1.67	$^\circ\text{C}/\text{W}$
----------------	----------------------------------	-----	------	---------------------------

**Table 4: Electrical Characteristics ( $T_{case} = 25\text{ }^\circ\text{C}$  unless otherwise specified)**

Symbol	Parameter	Test Conditions	Min.	Typ.	Max.	Unit
$I_{CES}$	Collector Cut-off Current ( $V_{BE} = 0$ )	$V_{CE} = 1700\text{ V}$ $V_{CE} = 1700\text{ V}$ $T_C = 125\text{ }^\circ\text{C}$			0.2 2	mA mA
$I_{EBO}$	Emitter Cut-off Current ( $I_C = 0$ )	$V_{EB} = 5\text{ V}$			10	$\mu\text{A}$
$V_{CEO(sus)}^*$	Collector-Emitter Sustaining Voltage ( $I_B = 0$ )	$I_C = 10\text{ mA}$	800			V
$V_{EBO}$	Emitter-Base Voltage ( $I_C = 0$ )	$I_E = 10\text{ mA}$	10			V
$V_{CE(sat)}^*$	Collector-Emitter Saturation Voltage	$I_C = 12\text{ A}$ $I_B = 3\text{ A}$			3	V
$V_{BE(sat)}^*$	Base-Emitter Saturation Voltage	$I_C = 12\text{ A}$ $I_B = 3\text{ A}$		0.95	1.5	V
$h_{FE}$	DC Current Gain	$I_C = 1\text{ A}$ $V_{CE} = 5\text{ V}$ $I_C = 12\text{ A}$ $V_{CE} = 5\text{ V}$	6.5	30	9.5	
$t_s$ $t_f$	INDUCTIVE LOAD Storage Time Fall Time	$I_C = 12\text{ A}$ $f_h = 31250\text{ Hz}$ $I_{B(on)} = 1.9\text{ A}$ $I_{B(off)} = -8.1\text{ A}$ $V_{CE(fly)} = 1320\text{ V}$ $V_{BE(off)} = -2.7\text{ V}$ $L_{BB(off)} = 0.8\text{ }\mu\text{H}$		3.1 350	3.8 500	$\mu\text{s}$ ns
$t_s$ $t_f$	INDUCTIVE LOAD Storage Time Fall Time	$I_C = 6.5\text{ A}$ $f_h = 100\text{ kHz}$ $I_{B(on)} = 1.2\text{ A}$ $I_{B(off)} = -5.85\text{ A}$ $V_{CE(fly)} = 1220\text{ V}$ $V_{BE(off)} = -2.7\text{ V}$ $L_{BB(off)} = 0.25\text{ }\mu\text{H}$		1.7 180	2 250	$\mu\text{s}$ ns

\* Pulsed: Pulsed duration = 300  $\mu\text{s}$ , duty cycle  $\leq 1.5\%$ .

Figure 3: Safe Operating Area

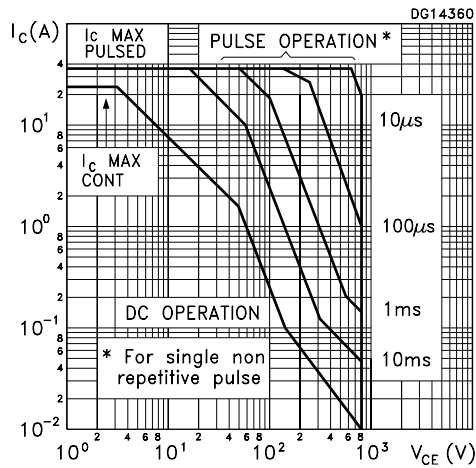

Figure 4: Output Characteristics

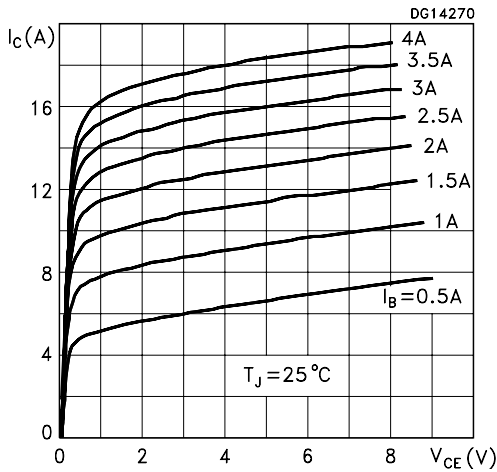

Figure 5: DC Current Gain

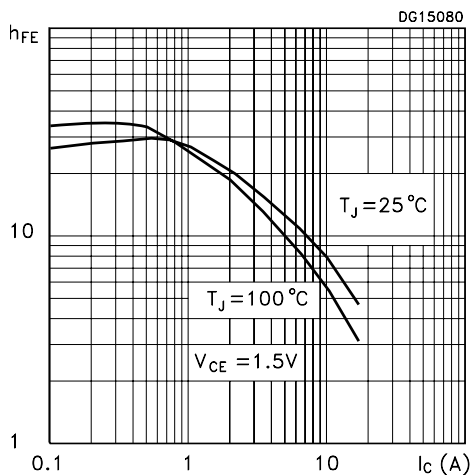

Figure 6: Derating Curve

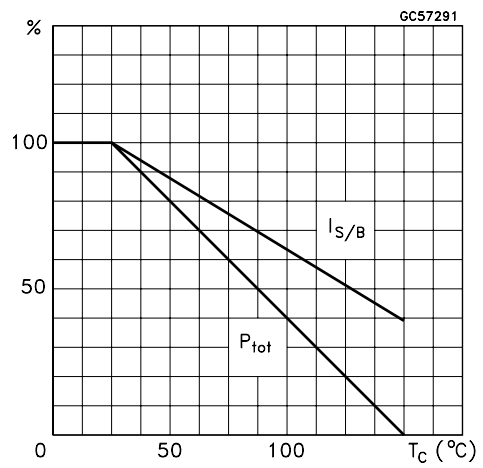

Figure 7: Reverse Biased SOA

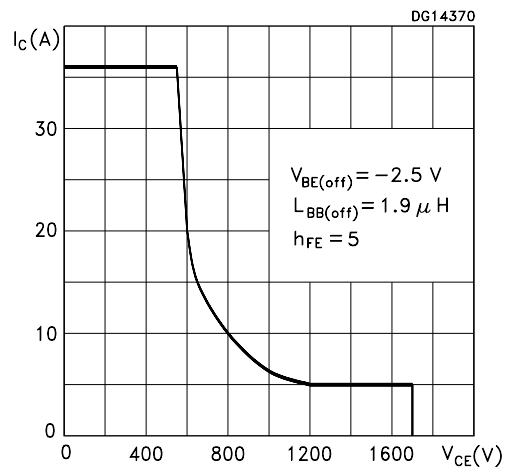

Figure 8: DC Current Gain

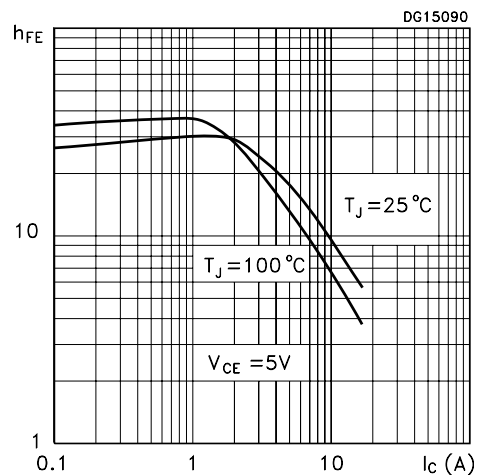

Figure 9: Collector-Emitter Saturation Voltage

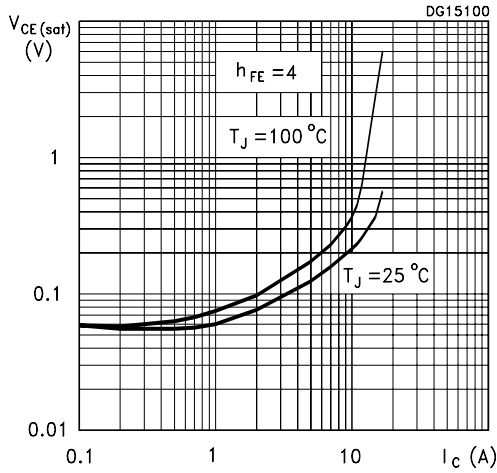

Figure 10: Power Losses

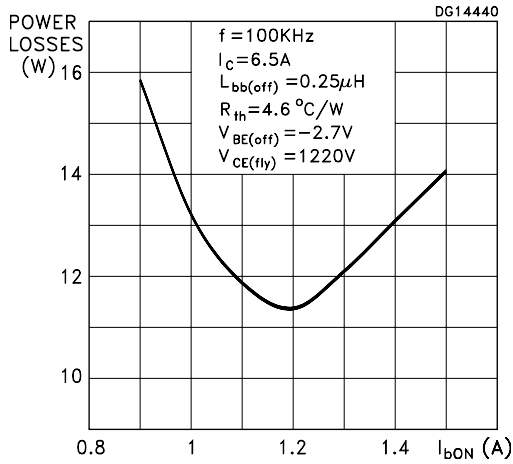

Figure 11: Inductive Load Switching Time

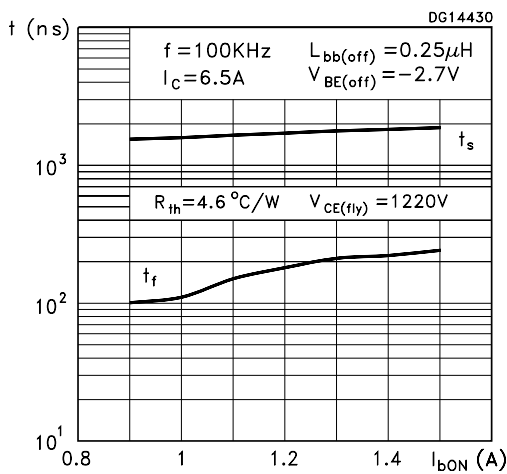

Figure 12: Base-Emitter Saturation Voltage

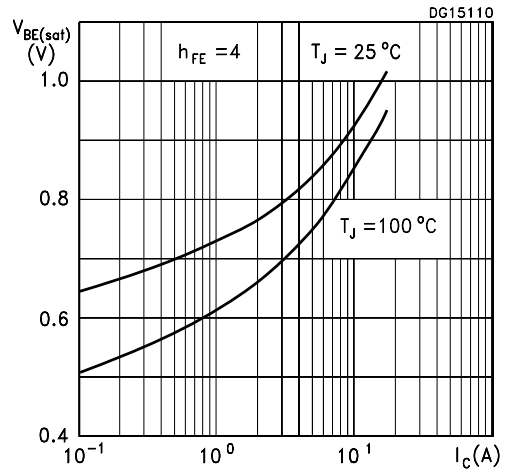

Figure 13: Power Losses

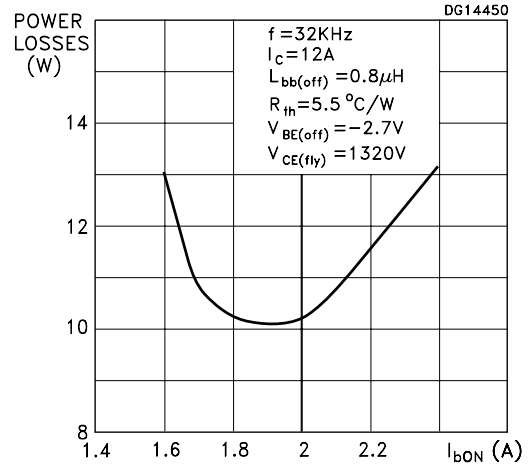

Figure 14: Inductive Load Switching Time

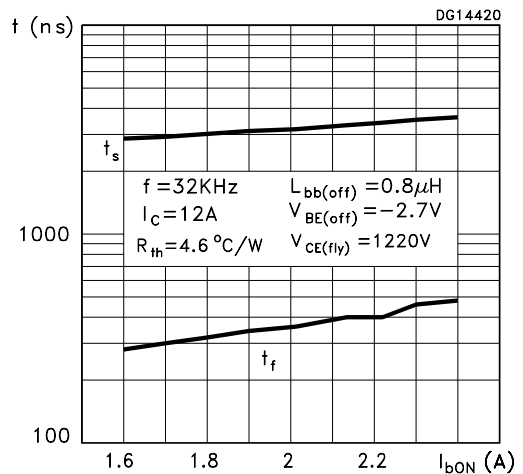

Figure 15: Power Losses and Inductive Load Switching Test Circuit

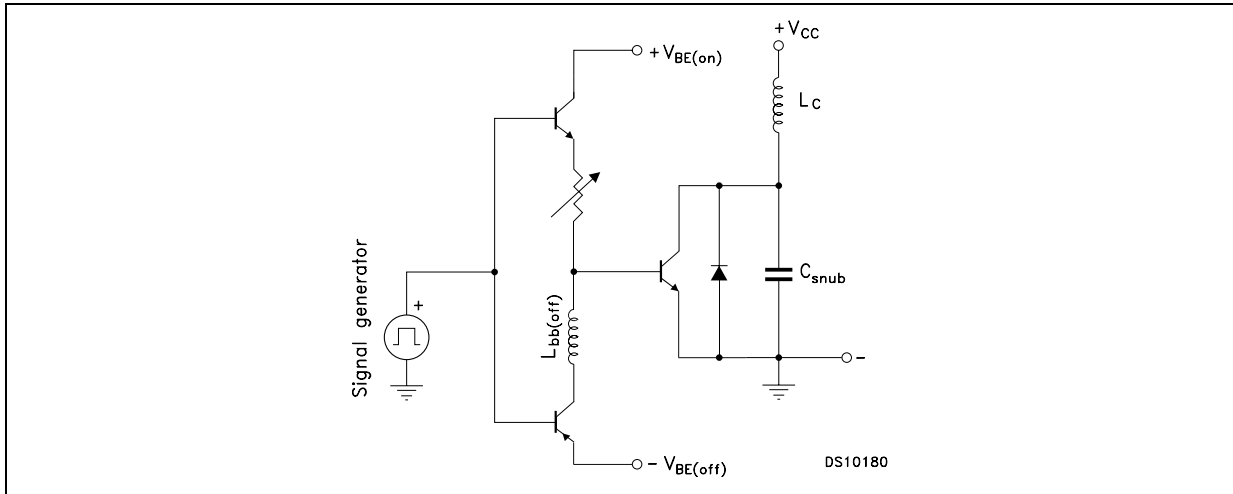
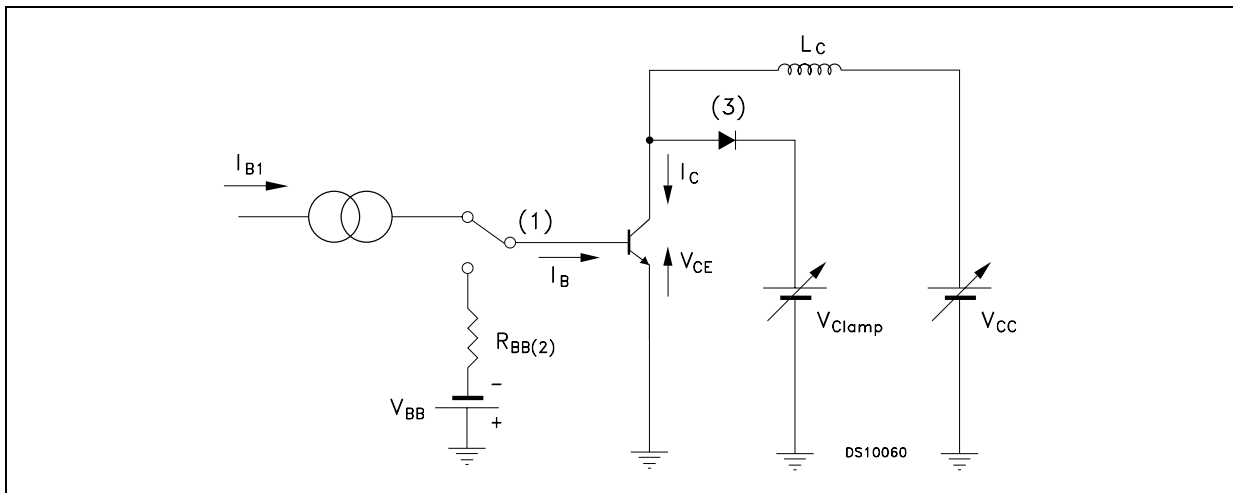
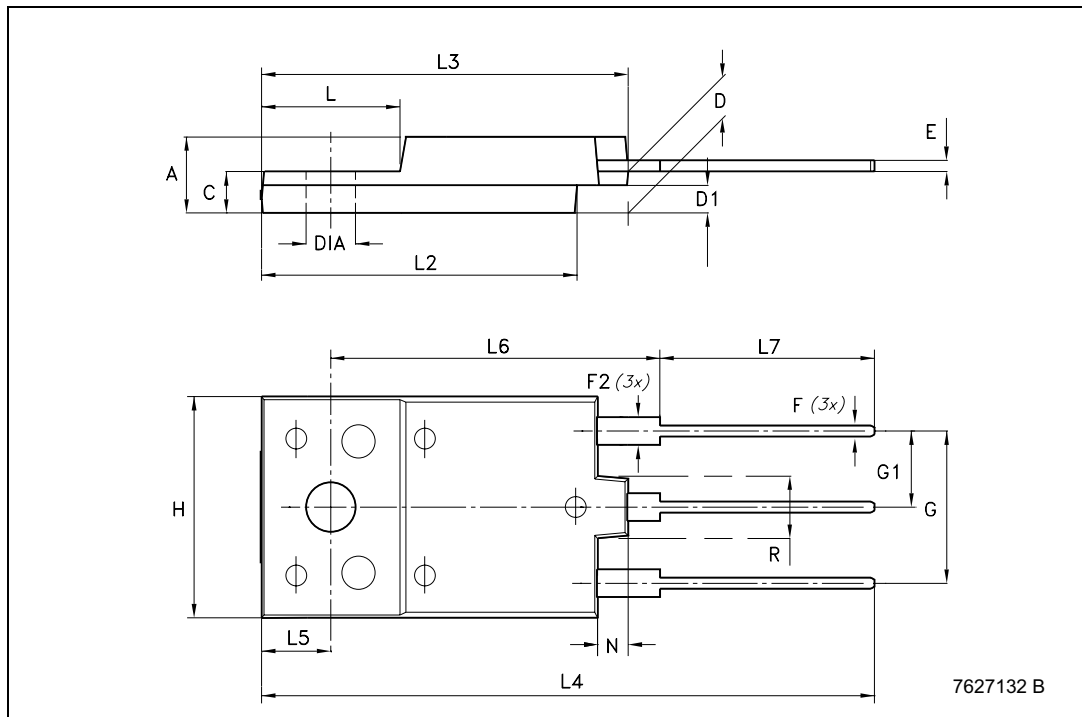

Figure 16: Reverse Biased Safe Operating Area Test Circuit



**ISOWATT218FX MECHANICAL DATA**

DIM.	mm.		
	MIN.	TYP	MAX.
A	5.30		5.70
C	2.80		3.20
D	3.10		3.50
D1	1.80		2.20
E	0.80		1.10
F	0.65		0.95
F2	1.80		2.20
G	10.30		11.50
G1		5.45	
H	15.30		15.70
L	9		10.20
L2	22.80		23.20
L3	26.30		26.70
L4	43.20		44.40
L5	4.30		4.70
L6	24.30		24.70
L7	14.60		15
N	1.80		2.20
R	3.80		4.20
Dia	3.40		3.80



**Figure 5: Revision History**

<b>Release Date</b>	<b>Version</b>	<b>Change Designator</b>
30-May-2005	1	Initial Release.
19-Dec-2005	2	New $h_{FE}$ value in table 4

Information furnished is believed to be accurate and reliable. However, STMicroelectronics assumes no responsibility for the consequences of use of such information nor for any infringement of patents or other rights of third parties which may result from its use. No license is granted by implication or otherwise under any patent or patent rights of STMicroelectronics. Specifications mentioned in this publication are subject to change without notice. This publication supersedes and replaces all information previously supplied. STMicroelectronics products are not authorized for use as critical components in life support devices or systems without express written approval of STMicroelectronics.

The ST logo is a registered trademark of STMicroelectronics  
All other names are the property of their respective owners

© 2005 STMicroelectronics - All Rights Reserved

STMicroelectronics group of companies

Australia - Belgium - Brazil - Canada - China - Czech Republic - Finland - France - Germany - Hong Kong - India - Israel - Italy - Japan -  
Malaysia - Malta - Morocco - Singapore - Spain - Sweden - Switzerland - United Kingdom - United States of America

[www.st.com](http://www.st.com)





Компания «ЭлектроПласт» предлагает заключение долгосрочных отношений при поставках импортных электронных компонентов на взаимовыгодных условиях!

Наши преимущества:

- Оперативные поставки широкого спектра электронных компонентов отечественного и импортного производства напрямую от производителей и с крупнейших мировых складов;
- Поставка более 17-ти миллионов наименований электронных компонентов;
- Поставка сложных, дефицитных, либо снятых с производства позиций;
- Оперативные сроки поставки под заказ (от 5 рабочих дней);
- Экспресс доставка в любую точку России;
- Техническая поддержка проекта, помощь в подборе аналогов, поставка прототипов;
- Система менеджмента качества сертифицирована по Международному стандарту ISO 9001;
- Лицензия ФСБ на осуществление работ с использованием сведений, составляющих государственную тайну;
- Поставка специализированных компонентов (Xilinx, Altera, Analog Devices, Intersil, Interpoint, Microsemi, Aeroflex, Peregrine, Syfer, Eurofarad, Texas Instrument, Miteq, Cobham, E2V, MA-COM, Hittite, Mini-Circuits, General Dynamics и др.);

Помимо этого, одним из направлений компании «ЭлектроПласт» является направление «Источники питания». Мы предлагаем Вам помощь Конструкторского отдела:

- Подбор оптимального решения, техническое обоснование при выборе компонента;
- Подбор аналогов;
- Консультации по применению компонента;
- Поставка образцов и прототипов;
- Техническая поддержка проекта;
- Защита от снятия компонента с производства.



#### Как с нами связаться

**Телефон:** 8 (812) 309 58 32 (многоканальный)

**Факс:** 8 (812) 320-02-42

**Электронная почта:** [org@eplast1.ru](mailto:org@eplast1.ru)

**Адрес:** 198099, г. Санкт-Петербург, ул. Калинина, дом 2, корпус 4, литера А.