



TGAR-W1061+-4G-M12

Industrial EN50155 IEEE 802.11 a/b/g/n 4G LTE Cellular Router with 1x10/100/1000Base-T(X) PoE P.D., IP-67

Features

- High Speed Air Connectivity: WLAN interface support up to 300Mbps link speed
- Provide 1 port 10/100/1000Base-T(X) port with PoE P.D.
- **4G LTE Modem dial up included**
- Provide HNAT enhance LAN to WAN routing performance
- Highly Security Capability: WEP/WPA/WPA-PSK(TKIP,AES)/WPA2/WPA2-PSK(TKIP,AES)/802.1X Authentication supported
- Secured Management by HTTPs
- Various kind of WAN Connection Type supported: Dynamic/Static IP, PPPoE, Modem/Dial Up
- Support client operating mode
- IP table to prevent access from unauthorized IP address
- Support VPN for secured network connection (Open VPN , PPTP, IPSEC, VPN)
- Support NAT Setting (Virtual Server , Port Trigger , DMZ , UPnP)
- 1KV isolation for PoE P.D.
- Wireless connecting status monitoring
- Versatile modes & event alarm by e-mail
- Event Warning by Syslog, Email, SNMP Trap, Relay and Beeper
- Rigid IP-67 waterproof housing design



Introduction

TGAR-W1061+-4G-M12 is a reliable IEEE 802.11 a/b/g/n WLAN VPN router with 1 ports 10/100/1000Base-T(X) router where ETH1 for LAN. It supports 802.1X and MAC filter for security control. It could be configured to operate in 3 modes of routing function: Dynamic/Static IP route, PPPoE authentication, and Modem (GPRS/3G/3.5G /LTE Modem) dial up. Users can set up WLAN environment to fulfill demands of various applications rapidly by dialing up cellular modems. In addition, TGAR-W1061+-4G-M12 also provides P.D. feature which is fully compliant with IEEE802.3af PoE P.D. specification. This feature extends the layout up to 100 meters. Therefore, TGAR-W1061+-4G-M12 is one of the best solution for applications of wireless communication.

Application

In practical operation of wireless access point, Windows utility (Open-Version) is supported. This utility is very helpful for you to search and configure IP of access point on the industrial network.

In addition, the wireless access point support various kinds of operation modes include AP/Dual Client /Bridge /AP-Client Mode.

Dimension

Dimension (Unit =mm)

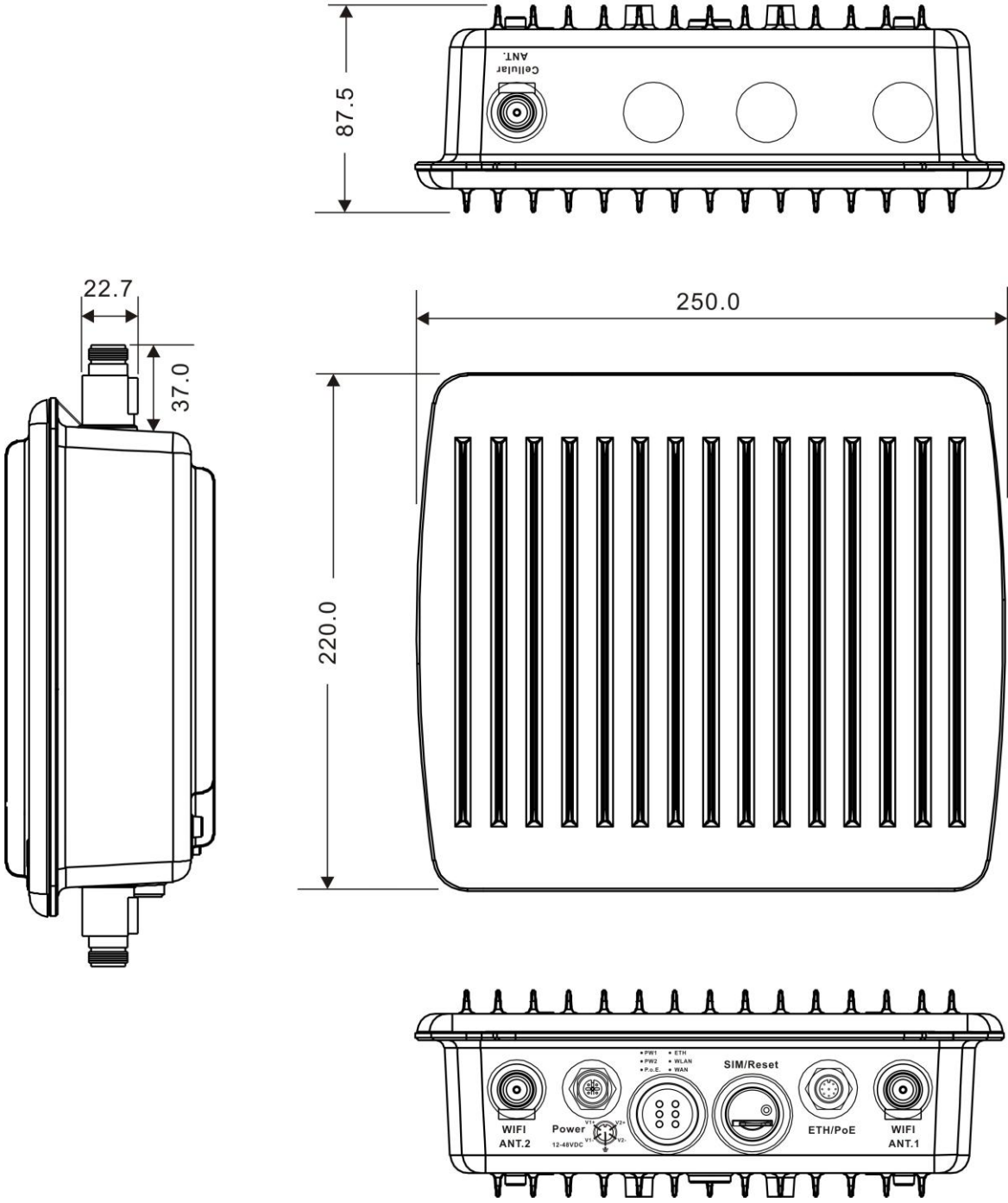

* All specifications are subject to change without notice.

Specifications

ORing AP Router Model	TGAR-W1061+-4G-M12
Physical Ports	
10/100/1000Base-T(X) Ports in M12 Auto MDI/MDIX (8-pin A-coding)	1
PoE P.D. port	Fully compliant with IEEE 802.3af Power Device specification Over load & short circuit protection Isolation Voltage: 1000 VDC min. Isolation Resistance : 10 ⁸ ohms min
Sim Card Slot	1
Cellular Interface	
Cellular Standard	GSM / GPRS/ EGPRS/ EDGE / WCDMA / HSDPA / HSUPA /HSPA+ /LTE
Antenna Connector	1 x External N-Type female antenna connector
Band Option	America(US) LTE: 700/1700/2100/ MHz UMTS/HSDPA/HSUPA/HSPA+/DC-HSPA+: 800/850/1900/2100 MHz GSM/GPRS/EDGE: 850/900/1800/1900 MHz Europe(EU) LTE: 800/900/1800/2100/2600 MHz UMTS/HSDPA/HSUPA/HSPA+/DC-HSPA+: 900/2100 MHz GSM/GPRS/EDGE: 900/1800/1900 MHz
WLAN interface	
Antenna Connector	2 x External N-Type female antenna connector
Modulation	IEEE802.11b: CCK/DQPSK/DBPSK IEEE802.11a/g: OFDM IEEE802.11n: BPSK, QPSK, 16-QAM, 64-QAM
Frequency Band	America / FCC: 2.412~2.462 GHz (11 channels) 5.180~5.240 GHz & 5.745~5.825 GHz (9 channels) Europe CE / ETSI: 2.412~2.472 GHz (13 channels) 5.180~5.240 GHz (4 channels)
Transmission Rate	802.11b: 1/2/5.5/11 Mbps 802.11a/g: 6/9/12/18/24/36/48/54 Mbps 802.11n(40MHz): UP to 300 Mbps
Transmit Power	802.11a: 12dBm ± 1.5dBm@54Mbps 802.11b: 17dBm ± 1.5dBm@11Mbps 802.11g: 16dBm ± 1.5dBm@54Mbps 802.11gn HT20: 15dBm ± 1.5dBm @MCS7 802.11gn HT40: 14dBm ± 1.5dBm @MCS7 802.11an HT20: 12dBm ± 1.5dBm @MCS7 802.11an HT40: 11dBm ± 1.5dBm @MCS7
Receiver Sensitivity	802.11a : -76dBm ± 2dBm@54Mbps 802.11b : -85dBm ± 2dBm@11Mbps 802.11g : -76dBm ± 2dBm@54Mbps 802.11gn HT20:-75dBm ± 2dBm@MCS7 802.11gn HT40:-72dBm ± 2dBm@MCS7 802.11an HT20:-74dBm ± 2dBm@MCS7 802.11an HT40:-71dBm ± 2dBm@MCS7
Encryption Security	WEP: (64-bit ,128-bit key supported) WPA/WPA2 :802.11i(WEP and AES encryption) WPA-PSK (256-bit key pre-shared key supported)

	802.1X Authentication supported TKIP encryption
Wireless Security	SSID broadcast disable
LED indicators	
Power indicator	3 x LEDs, PW1/PW2/PoE Green On : Power is on and booting up
10/100/1000T RJ45 port indicator	1 x LEDs, Green for port Link/ Act at 1000Mbps
WLAN LEDs:	1 x LEDs, Green for WLAN Link /Act
WAN LED	1 x LEDs, Green for WAN is on and functioning Normal
Power	
Redundant Input power	Dual DC inputs. 12-48VDC on M12 connector
Power consumption	9.5W
Overload current protection	Present
Reverse polarity protection	Present
Physical Characteristic	
Enclosure	IP-67
Dimension (W x D x H)	310 (W) x 310(D) x 87 (H) (12.2 x 12.2 x 3.4 inch)
Weight (g)	3990g
Environmental	
Storage Temperature	-40 to 85oC (-40 to 185°F)
Operating Temperature	-25 to 70°C (-13 to 158°F)
Operating Humidity	5% to 95% Non-condensing
Regulatory approvals	
EMI	FCC Part 15, CISPR (EN55022) class A, EN50155 (EN50121-3-2)
EMS	EN61000-4-2 (ESD), EN61000-4-3 (RS), EN61000-4-4 (EFT), EN61000-4-5 (Surge), EN61000-4-6 (CS), EN61000-4-8, EN61000-4-11
Shock	IEC60068-2-27, EN61373
Free Fall	IEC60068-2-32
Vibration	IEC60068-2-6, EN61373
Rail Traffic	EN50155
Cooling	EN60068-2-1
Dry Heat	En60068-2-2
Safety	EN60950-1
Warranty	5 years

Ordering Information

TGAR-W **A B C D E F F**

Code Definition	Cellular Module Number	2 nd Wireless Mode	1 st Wireless Mode	Giga Ethernet Port Number	PoE Identification	Cellular Generation
Option	1: One SIM	1: 802.11 b/g 2: 802.11 a 3: 802.11 a/b/g 4: 802.11 b/g/n 5: 802.11 a/n 6: 802.11 a/b/g/n	1: 802.11 b/g 2: 802.11 a 3: 802.11 a/b/g 4: 802.11 b/g/n 5: 802.11 a/n 6: 802.11 a/b/g/n	1: 1 ports	+ : PoE P.D. present at ETH	4G :LTE

	Model Name	Description
Available	TGAR-W1061+-4G-M12_US	Industrial IEEE 802.11 a/b/g/n 4G LTE Cellular router with 1x10/100/1000Base-T(X), PoE P.D., IP-67 grade, US band
Model	TGAR-W1061+-4G-M12_EU	Industrial IEEE 802.11 a/b/g/n 4G LTE Cellular router with 1x10/100/1000Base-T(X), PoE P.D., IP-67 grade, EU band

Packing List

- TGAR-W1061+-4G-M12 x 1
- Wall Mount Kit x 1
- CD x 1
- 2.4GHz/5GHz Antenna x 2
- Quick Installation Guide x 1
- Cellular Antenna x 1

Optional Accessories

- DR-45 series : 45 Watts power supply
- DR-120 series : 120 Watts power supply
- RF Antenna Base series
- DR-75 series : 75 Watts power supply
- WLAN RF Antenna series
- RF Cable series



Компания «ЭлектроПласт» предлагает заключение долгосрочных отношений при поставках импортных электронных компонентов на взаимовыгодных условиях!

Наши преимущества:

- Оперативные поставки широкого спектра электронных компонентов отечественного и импортного производства напрямую от производителей и с крупнейших мировых складов;
- Поставка более 17-ти миллионов наименований электронных компонентов;
- Поставка сложных, дефицитных, либо снятых с производства позиций;
- Оперативные сроки поставки под заказ (от 5 рабочих дней);
- Экспресс доставка в любую точку России;
- Техническая поддержка проекта, помощь в подборе аналогов, поставка прототипов;
- Система менеджмента качества сертифицирована по Международному стандарту ISO 9001;
- Лицензия ФСБ на осуществление работ с использованием сведений, составляющих государственную тайну;
- Поставка специализированных компонентов (Xilinx, Altera, Analog Devices, Intersil, Interpoint, Microsemi, Aeroflex, Peregrine, Syfer, Eurofarad, Texas Instrument, Miteq, Cobham, E2V, MA-COM, Hittite, Mini-Circuits, General Dynamics и др.);

Помимо этого, одним из направлений компании «ЭлектроПласт» является направление «Источники питания». Мы предлагаем Вам помощь Конструкторского отдела:

- Подбор оптимального решения, техническое обоснование при выборе компонента;
- Подбор аналогов;
- Консультации по применению компонента;
- Поставка образцов и прототипов;
- Техническая поддержка проекта;
- Защита от снятия компонента с производства.



Как с нами связаться

Телефон: 8 (812) 309 58 32 (многоканальный)

Факс: 8 (812) 320-02-42

Электронная почта: org@eplast1.ru

Адрес: 198099, г. Санкт-Петербург, ул. Калинина, дом 2, корпус 4, литера А.