

# MAXIMUM SOLUTIONS

## Mill-Max Now Offers Nine Sizes of Beryllium Nickel Spring Contacts for High Temperature Applications.



Mill-Max offers nine contacts (#19, #24, #25, #26, #27, #33, #38, #56, #58) made from Beryllium Nickel Alloy 360 (UNS N03360.) Contacts made from Beryllium Nickel are recommended for receptacle applications where the operating temperature exceeds 150°C. Some common applications for these contacts are found in: the oil industry for down-hole wells and exploration; "Test & Burn-in" sockets for stress testing electronic devices (i.e. chips;) high temperature commercial lighting fixtures (e.g. Halogen lamps) and autoclave sterilization for the medical industry. BeNi is suitable for continuous use up to 250°C, and periodic use up to 350°C, without significant loss of its spring properties (see graph.) For use below 150°C, Mill-Max has an extensive range of

29 standard Beryllium Copper (Alloy 172) spring contacts.

These nine contacts are available assembled in a wide range of standard precision-machined receptacles (discrete sockets for printed circuit boards) and various types of socket assemblies (DIP, SIP etc.) These contacts are the internal spring member of the highly reliable, two piece Mill-Max receptacle and are not sold as individual items.

### Properties of BeNi Alloy 360

Chemical composition: Ni 97.6%, Be 1.9%, Ti 0.5%  
 Modulus of Elasticity: 27-30x10<sup>6</sup> psi  
 Tensile Strength: 245x10<sup>3</sup> psi min.  
 Yield Strength (0.2% offset): 200x10<sup>3</sup> psi min.  
 Hardness: 49 Rockwell C

### Contact Material and Stress Relaxation at High Temperature

Mill-Max contacts are made from either beryllium copper or beryllium nickel that has been heat treated to achieve ultimate spring properties. The graph illustrates how beryllium copper loses its spring properties over time at a high temperature (225°C). Thus, for burn-in applications and continuous operation above 150°C, beryllium nickel should be substituted for beryllium copper.

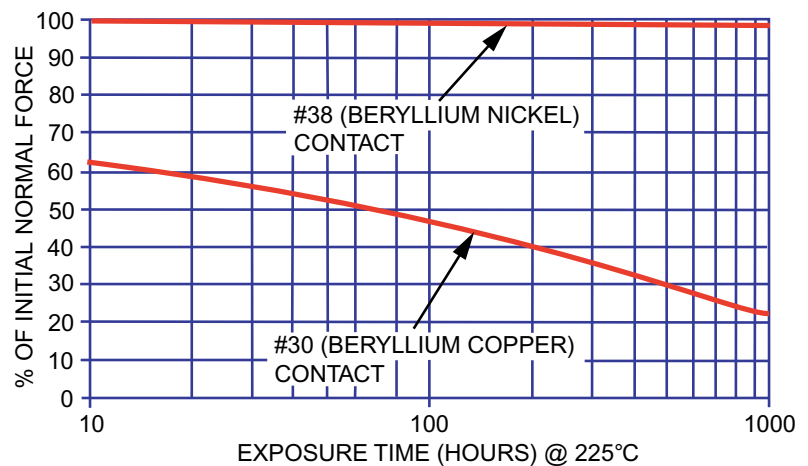

(11/12 -- PR548)

Mill-Max Mfg. Corp. • 190 Pine Hollow Road, Oyster Bay, NY 11771  
 516-922-6000 • Fax: 516-922-9253 • www.mill-max.com



## #25 CONTACT

FOR .015-.020 DIAMETER PINS ( $d=.003$ )  
3-FINGER, GROUP A (see page 214)

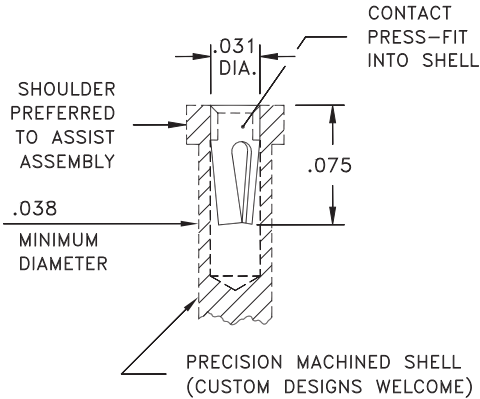

**CONTACT MATERIAL:**  
BERYLLIUM NICKEL Alloy 360, Heat Treated

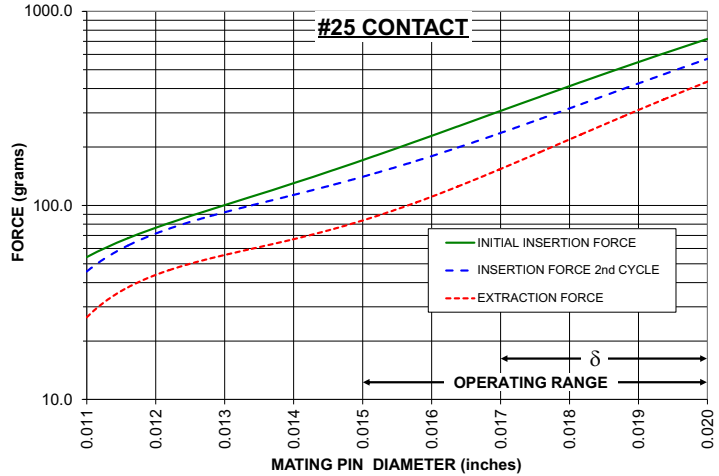

The insertion/extraction/normal force characteristics above were derived using 30 microinch gold plated contact and polished steel gauge pins having a bullet-shaped tip.

The curves represent typical average values; they are best used to compare the differences between similar size contacts and to guide you in selecting one that is suitable for your application. Your results may vary, so for your specification, we encourage you to obtain complimentary samples for your evaluation.

## #38 CONTACT

FOR .015-.025 DIAMETER PINS ( $d=.004$ )  
4-FINGER, GROUP C (see page 214)

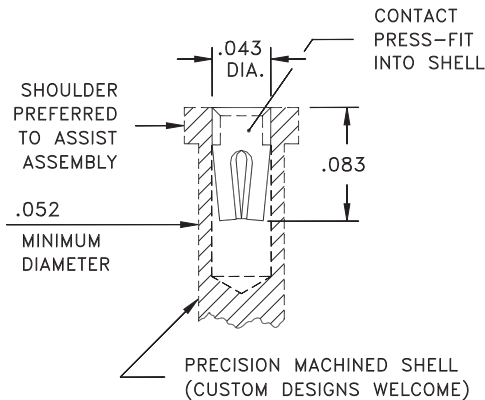

**CONTACT MATERIAL:**  
BERYLLIUM NICKEL Alloy 360, Heat Treated

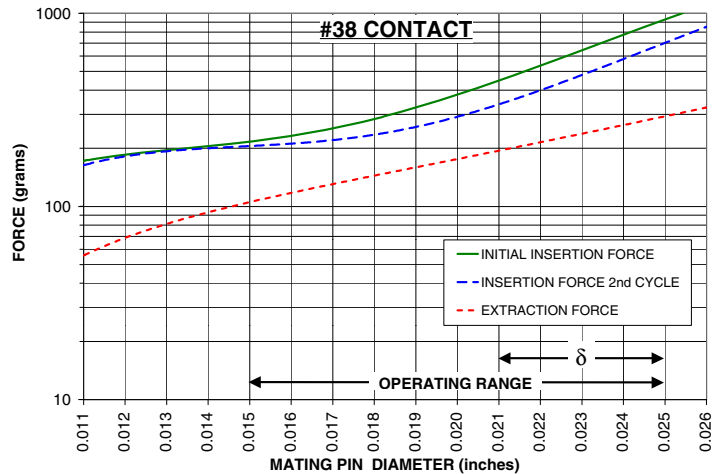

The insertion/extraction/normal force characteristics above were derived using 30 microinch gold plated contact and polished steel gauge pins having a bullet-shaped tip.

The curves represent typical average values; they are best used to compare the differences between similar size contacts and to guide you in selecting one that is suitable for your application. Your results may vary, so for your specification, we encourage you to obtain complimentary samples for your evaluation.

## #19 CONTACT

FOR .020-.032 DIAMETER PINS ( $d=.003$ )  
6-FINGER, GROUP K (see page 214)

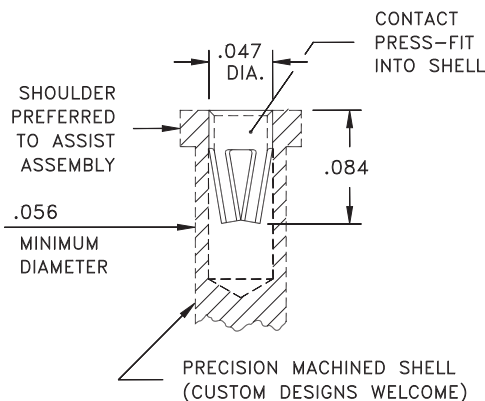

**CONTACT MATERIAL:**  
BERYLLIUM NICKEL Alloy 360, Heat Treated

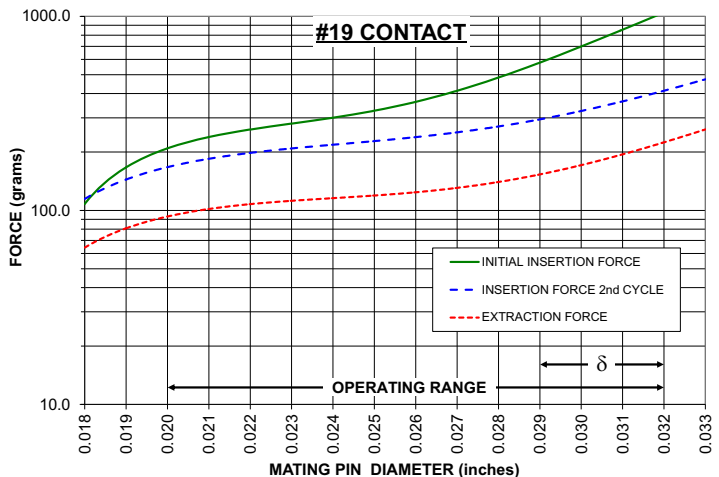

The insertion/extraction/normal force characteristics above were derived using 30 microinch gold plated contact and polished steel gauge pins having a bullet-shaped tip.

The curves represent typical average values; they are best used to compare the differences between similar size contacts and to guide you in selecting one that is suitable for your application. Your results may vary, so for your specification, we encourage you to obtain complimentary samples for your evaluation.

## #26 CONTACT

FOR .022-.032 DIAMETER PINS ( $d=.005$ )  
4-FINGER, GROUP D (see page 214)

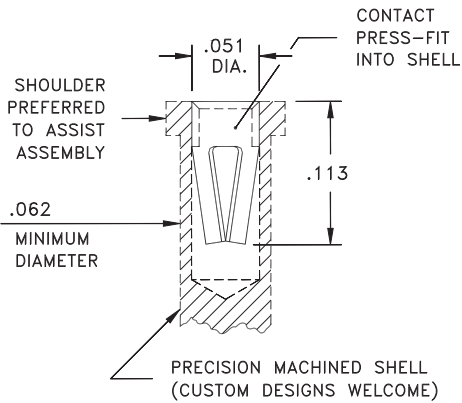

**CONTACT MATERIAL:**  
BERYLLIUM NICKEL Alloy 360, Heat Treated

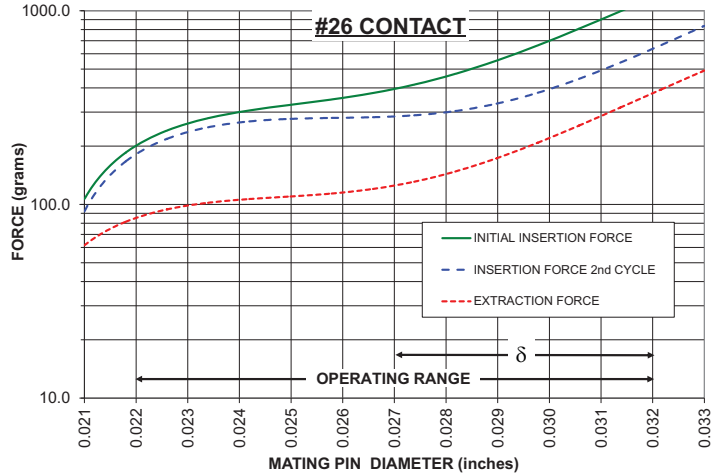

The insertion/extraction/normal force characteristics above were derived using 30 microinch gold plated contact and polished steel gauge pins having a bullet-shaped tip.

The curves represent typical average values; they are best used to compare the differences between similar size contacts and to guide you in selecting one that is suitable for your application. Your results may vary, so for your specification, we encourage you to obtain complimentary samples for your evaluation.

## #56 CONTACT

FOR .025-.037 DIA. & .025 SQ. ( $d=.009$ )  
6-FINGER, GROUP D (see page 214)

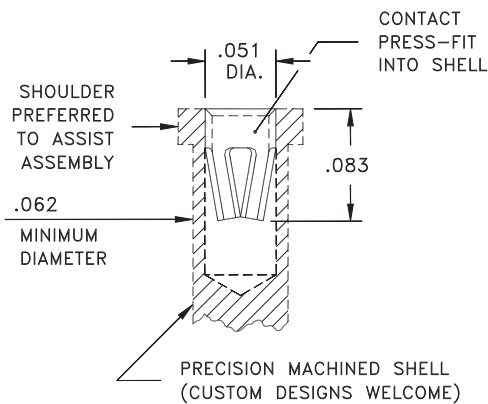

**CONTACT MATERIAL:**  
BERYLLIUM NICKEL Alloy 360, Heat Treated

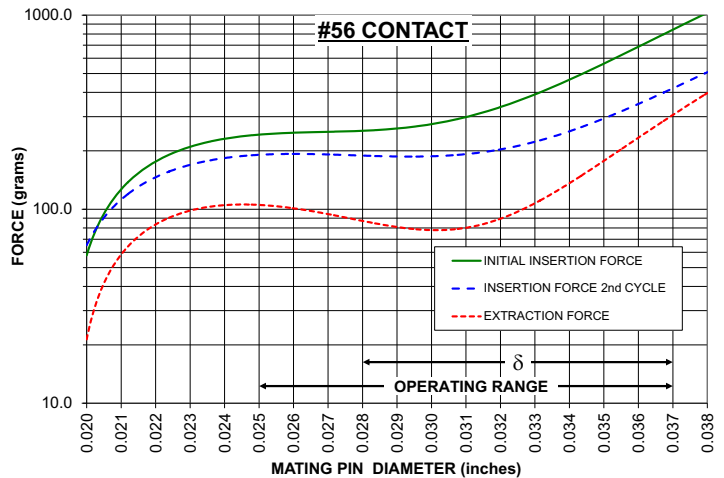

The insertion/extraction/normal force characteristics above were derived using 30 microinch gold plated contact and polished steel gauge pins having a bullet-shaped tip.

The curves represent typical average values; they are best used to compare the differences between similar size contacts and to guide you in selecting one that is suitable for your application. Your results may vary, so for your specification, we encourage you to obtain complimentary samples for your evaluation.

## #58 CONTACT

FOR .037-.043 DIAMETER PINS ( $d=.003$ )  
6-FINGER, GROUP L (see page 214)

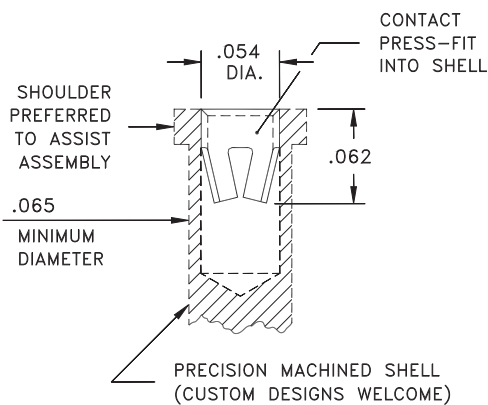

**CONTACT MATERIAL:**  
BERYLLIUM NICKEL Alloy 360, Heat Treated

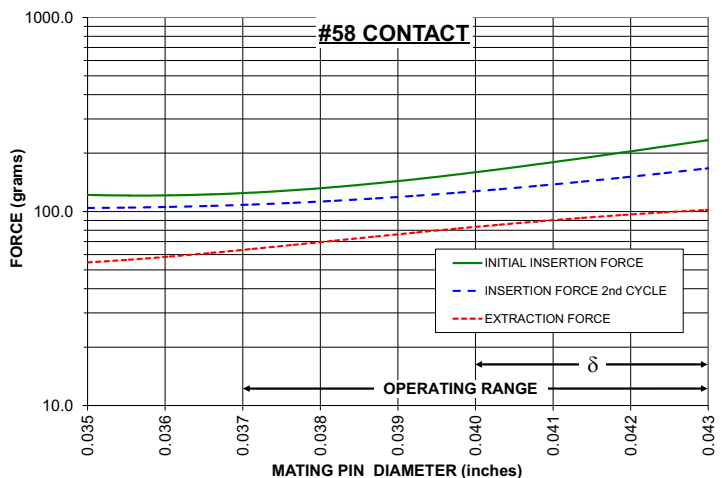

The insertion/extraction/normal force characteristics above were derived using 30 microinch gold plated contact and polished steel gauge pins having a bullet-shaped tip.

The curves represent typical average values; they are best used to compare the differences between similar size contacts and to guide you in selecting one that is suitable for your application. Your results may vary, so for your specification, we encourage you to obtain complimentary samples for your evaluation.

## #24 CONTACT

FOR .032-.046 DIAMETER PINS ( $d = .009$ )  
4-FINGER, GROUP E (see page 214)

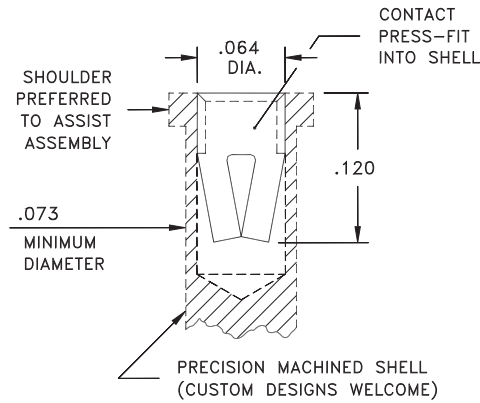

**CONTACT MATERIAL:**  
BERYLLIUM NICKEL Alloy 360, Heat Treated

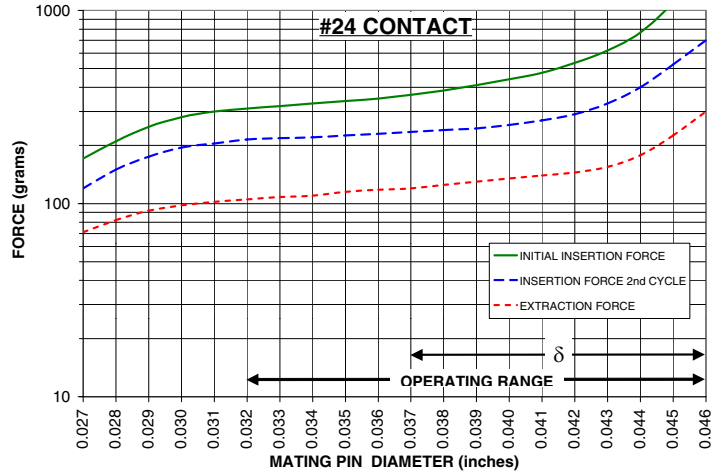

The insertion/extraction/normal force characteristics above were derived using 30 microinch gold plated contact and polished steel gauge pins having a bullet-shaped tip.

The curves represent typical average values; they are best used to compare the differences between similar size contacts and to guide you in selecting one that is suitable for your application. Your results may vary, so for your specification, we encourage you to obtain complimentary samples for your evaluation.

## #33 CONTACT

FOR .048-.064 DIAMETER PINS ( $d = .008$ )  
4-FINGER, GROUP G (see page 214)

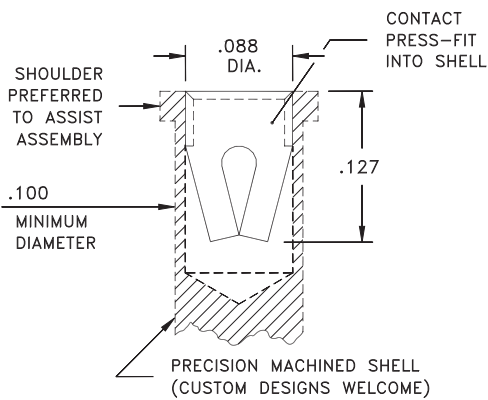

**CONTACT MATERIAL:**  
BERYLLIUM NICKEL Alloy 360, Heat Treated

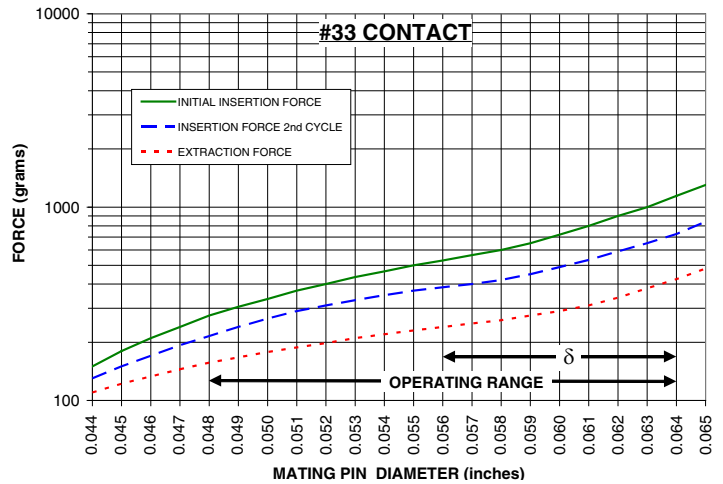

The insertion/extraction/normal force characteristics above were derived using 30 microinch gold plated contact and polished steel gauge pins having a bullet-shaped tip.

The curves represent typical average values; they are best used to compare the differences between similar size contacts and to guide you in selecting one that is suitable for your application. Your results may vary, so for your specification, we encourage you to obtain complimentary samples for your evaluation.

## #27 CONTACT

FOR .065-.082 DIAMETER PINS ( $d = .012$ )  
4-FINGER, GROUP H (see page 214)

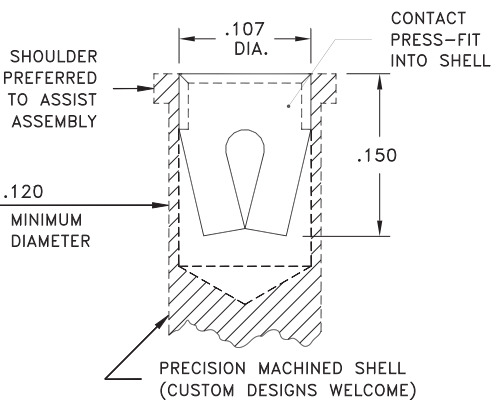

**CONTACT MATERIAL:**  
BERYLLIUM NICKEL Alloy 360, Heat Treated

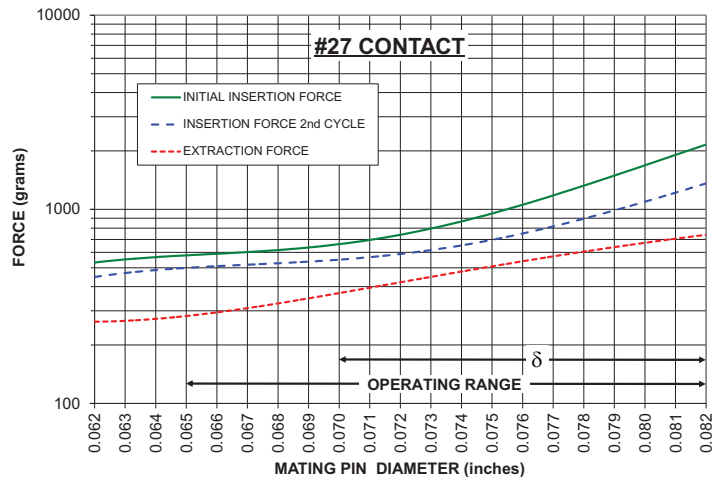

The insertion/extraction/normal force characteristics above were derived using 30 microinch gold plated contact and polished steel gauge pins having a bullet-shaped tip.

The curves represent typical average values; they are best used to compare the differences between similar size contacts and to guide you in selecting one that is suitable for your application. Your results may vary, so for your specification, we encourage you to obtain complimentary samples for your evaluation.



Компания «ЭлектроПласт» предлагает заключение долгосрочных отношений при поставках импортных электронных компонентов на взаимовыгодных условиях!

Наши преимущества:

- Оперативные поставки широкого спектра электронных компонентов отечественного и импортного производства напрямую от производителей и с крупнейших мировых складов;
- Поставка более 17-ти миллионов наименований электронных компонентов;
- Поставка сложных, дефицитных, либо снятых с производства позиций;
- Оперативные сроки поставки под заказ (от 5 рабочих дней);
- Экспресс доставка в любую точку России;
- Техническая поддержка проекта, помощь в подборе аналогов, поставка прототипов;
- Система менеджмента качества сертифицирована по Международному стандарту ISO 9001;
- Лицензия ФСБ на осуществление работ с использованием сведений, составляющих государственную тайну;
- Поставка специализированных компонентов (Xilinx, Altera, Analog Devices, Intersil, Interpoint, Microsemi, Aeroflex, Peregrine, Syfer, Eurofarad, Texas Instrument, Miteq, Cobham, E2V, MA-COM, Hittite, Mini-Circuits, General Dynamics и др.);

Помимо этого, одним из направлений компании «ЭлектроПласт» является направление «Источники питания». Мы предлагаем Вам помощь Конструкторского отдела:

- Подбор оптимального решения, техническое обоснование при выборе компонента;
- Подбор аналогов;
- Консультации по применению компонента;
- Поставка образцов и прототипов;
- Техническая поддержка проекта;
- Защита от снятия компонента с производства.



#### Как с нами связаться

**Телефон:** 8 (812) 309 58 32 (многоканальный)

**Факс:** 8 (812) 320-02-42

**Электронная почта:** [org@eplast1.ru](mailto:org@eplast1.ru)

**Адрес:** 198099, г. Санкт-Петербург, ул. Калинина, дом 2, корпус 4, литера А.