

HLMP-132x Series, HLMP-142x Series, HLMP-152x Series



T-1 (3 mm) High Intensity LED Lamps

Data Sheet



Description

This family of T-1 lamps is specially designed for applications requiring higher on-axis intensity than is achievable with a standard lamp. The light generated is focused to a narrow beam to achieve this effect.

Features

- High intensity
- Choice of 3 bright colors
 - High Efficiency Red
 - Yellow
 - High Performance Green
- Popular T-1 diameter package
- Selected minimum intensities
- Narrow viewing angle
- General purpose leads
- Reliable and rugged
- Available on tape and reel
- For more information, please refer to Tape and Reel Option data sheet

Package Dimensions

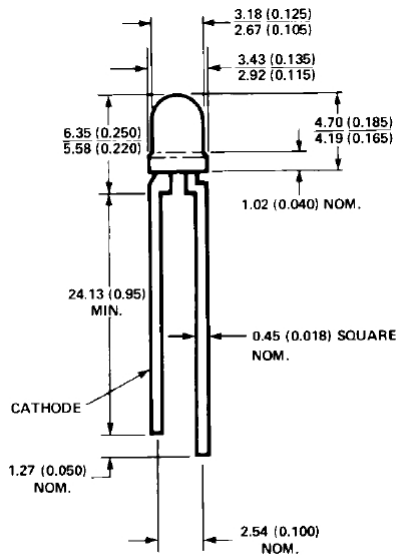

NOTES:
1. ALL DIMENSIONS ARE IN MILLIMETRES (INCHES).
2. AN EPOXY MENISCUS MAY EXTEND ABOUT 1mm (0.040") DOWN THE LEADS.

Selection Guide

| Part Number | Package Description | Color | Luminous Intensity I _v (mcd) @ 10 mA | |
|-----------------|------------------------------|------------------------|--|------|
| | | | Min. | Max. |
| HLMP-1321 | Tinted, Non-diffused | High Efficiency Red | 8.6 | - |
| HLMP-1321-G00xx | | | 8.6 | - |
| HLMP-1420 | Microtinted, Non-diffused | Yellow | 9.2 | - |
| HLMP-1421 | Tinted, Non-diffused | | 9.2 | - |
| HLMP-1421-F00xx | | 9.2 | - | |
| HLMP-1520 | Microtinted, Non-diffused | Green | 6.7 | - |
| HLMP-1521 | Tinted, Non-diffused | | 6.7 | - |
| HLMP-1521-E00xx | | 6.7 | - | |

Part Numbering System



Absolute Maximum Ratings at $T_A = 25^\circ\text{C}$

| Parameter | Red | Yellow | Green | Units |
|---|-------------|-------------|-------------|------------------|
| Peak Forward Current | 90 | 60 | 90 | mA |
| Average Forward Current ^[1] | 25 | 20 | 25 | mA |
| DC Current ^[2] | 30 | 20 | 30 | mA |
| Power Dissipation ^[3] | 135 | 85 | 135 | mW |
| Reverse Voltage ($I_R = 100 \mu\text{A}$) | 5 | 5 | 5 | V |
| Transient Forward Current ^[4] (10 μsec Pulse) | 500 | 500 | 500 | mA |
| LED Junction Temperature | 110 | 110 | 110 | $^\circ\text{C}$ |
| Operating Temperature Range | -40 to +100 | -40 to +100 | -20 to +100 | $^\circ\text{C}$ |
| Storage Temperature Range | -40 to +100 | -40 to +100 | -40 to +100 | |

Notes:

- See Figure 5 (Red), 10 (Yellow), or 15 (Green) to establish pulsed operating conditions.
- For Red and Green series derate linearly from 50°C at $0.5 \text{ mA}/^\circ\text{C}$. For Yellow series derate linearly from 50°C at $0.2 \text{ mA}/^\circ\text{C}$.
- For Red and Green series derate power linearly from 25°C at $1.8 \text{ mW}/^\circ\text{C}$. For Yellow series derate power linearly from 50°C at $1.6 \text{ mW}/^\circ\text{C}$.
- The transient peak current is the maximum non-recurring peak current that can be applied to the device without damaging the LED die and wirebond. It is not recommended that the device be operated at peak currents beyond the peak forward current listed in the Absolute Maximum Ratings.

Electrical Characteristics at $T_A = 25^\circ\text{C}$

| Symbol | Description | Device | | | Units | Test Conditions | |
|--------------------------|--|--------|------|------|--------------------|---|--------------------------------|
| | | HLMP- | Min. | Typ. | | | Max. |
| I_V | Luminous Intensity | 1320 | 8.6 | 30 | mcd | $I_F = 10\text{ mA}$ (Figure 3) | |
| | | 1321 | 8.6 | 30 | | | |
| | | 1420 | 9.2 | 15 | mcd | $I_F = 10\text{ mA}$ (Figure 8) | |
| | | 1421 | 9.2 | 15 | | | |
| | | 1520 | 6.7 | 22 | mcd | $I_F = 10\text{ mA}$ (Figure 3) | |
| 1521 | 6.7 | 22 | | | | | |
| $2\theta^{1/2}$ | Including Angle Between Half Luminous Intensity Points | All | | 45 | Deg. | $I_F = 10\text{ mA}$ See Note 1 (Figures 6, 11, 16, 21) | |
| λ_{PEAK} | Peak Wavelength | 132x | | 635 | nm | Measurement at Peak (Figure 1) | |
| | | 142X | | 583 | | | |
| | | 152X | | 565 | | | |
| $\Delta\lambda_{1/2}$ | Spectral Line Halfwidth | 132x | | 40 | nm | | |
| | | 142X | | 36 | | | |
| | | 152X | | 28 | | | |
| λ_d | Dominant Wavelength | 132x | | 626 | nm | See Note 2 (Figure 1) | |
| | | 142X | | 585 | | | |
| | | 152X | | 569 | | | |
| τ_s | Speed of Response | 132x | | 90 | ns | | |
| | | 142X | | 90 | | | |
| | | 152X | | 500 | | | |
| C | Capacitance | 132x | | 11 | pF | $V_F = 0; f = 1\text{ MHz}$ | |
| | | 142X | | 15 | | | |
| | | 152X | | 18 | | | |
| $R\theta_{\text{J-PIN}}$ | Thermal Resistance | All | | 290 | $^\circ\text{C/W}$ | Junction to Cathode Lead | |
| V_F | Forward Voltage | 132x | | 1.9 | 2.4 | V | $I_F = 10\text{ mA}$ |
| | | 142X | | 2.0 | 2.4 | | |
| | | 152X | | 2.1 | 2.7 | | |
| V_R | Reverse Breakdown Voltage | All | 5.0 | | | V | $I_R = 100\text{ }\mu\text{A}$ |
| η_V | Luminous Efficacy | 132x | | 145 | | $\frac{\text{lumens}}{\text{watt}}$ | See Note 3 |
| | | 142X | | 500 | | | |
| | | 152X | | 595 | | | |

Notes:

- $\theta^{1/2}$ is the off-axis angle at which the luminous intensity is half the axial luminous intensity.
- The dominant wavelength, λ_d , is derived from the CIE chromaticity diagram and represents the single wavelength which defines the color of the device.
- Radiant intensity, I_e , in watts/steradian, may be found from the equation $I_e = I_v/\eta_v$, where I_v is the luminous intensity in candelas and η_v is the luminous efficacy in lumens/watt.



Figure 1. Relative intensity vs. wavelength.

T-1 High Efficiency Red Non-Diffused

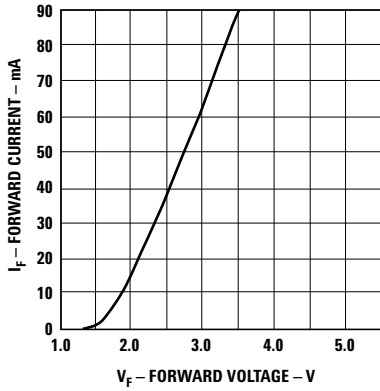

Figure 2. Forward current vs. forward voltage characteristics.

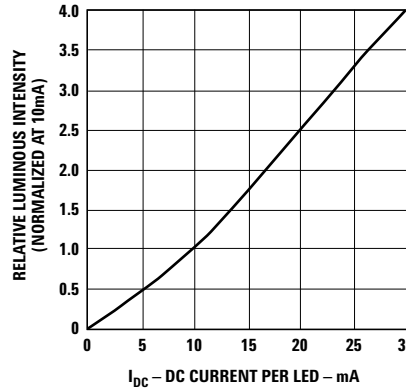

Figure 3. Relative luminous intensity vs. DC forward current.

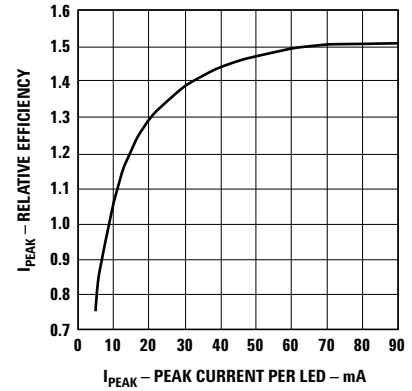

Figure 4. Relative efficiency (luminous intensity per unit current) vs. peak LED current.

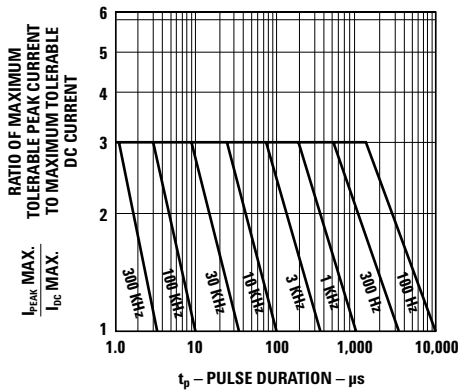

Figure 5. Maximum tolerable peak current vs. pulse duration. (I_{DC} MAX as per MAX ratings).

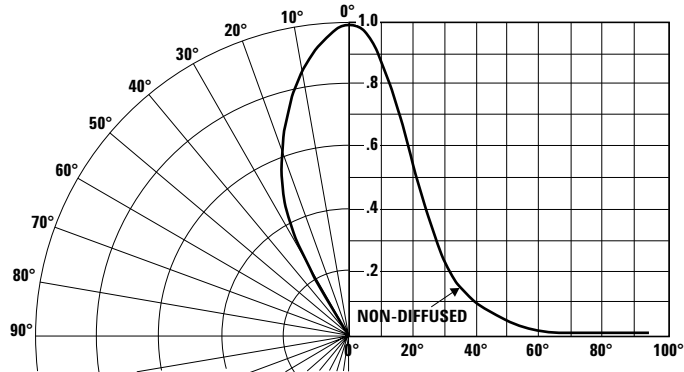

Figure 6. Relative luminous intensity vs. angular displacement.

T-1 Yellow Non-Diffused



Figure 7. Forward current vs. forward voltage characteristics.

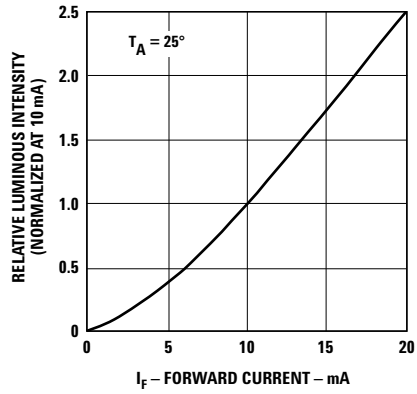

Figure 8. Relative luminous intensity vs. forward current.

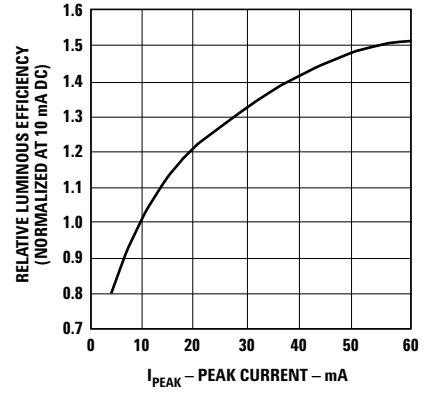

Figure 9. Relative efficiency (luminous intensity per unit current) vs. peak current.



Figure 10. Maximum tolerable peak current vs. pulse duration. (I_{DC} MAX as per MAX ratings).

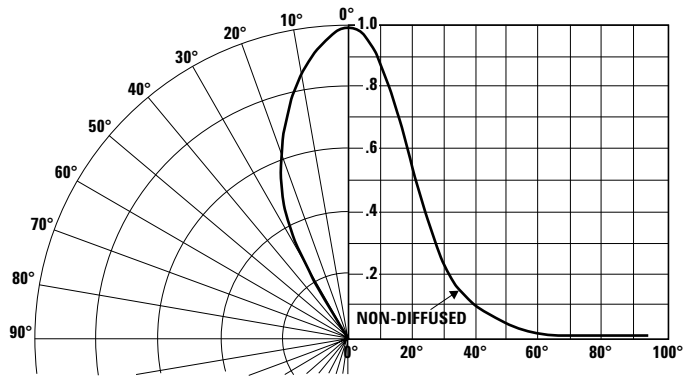

Figure 11. Relative luminous intensity vs. angular displacement.

T-1 Green Non-Diffused



Figure 12. Forward current vs. forward voltage characteristics.



Figure 13. Relative luminous intensity vs. forward current.



Figure 14. Relative efficiency (luminous intensity per unit current) vs. peak LED current.



Figure 15. Maximum tolerable peak current vs. pulse duration. (I_{DCMAX} as per MAX ratings).

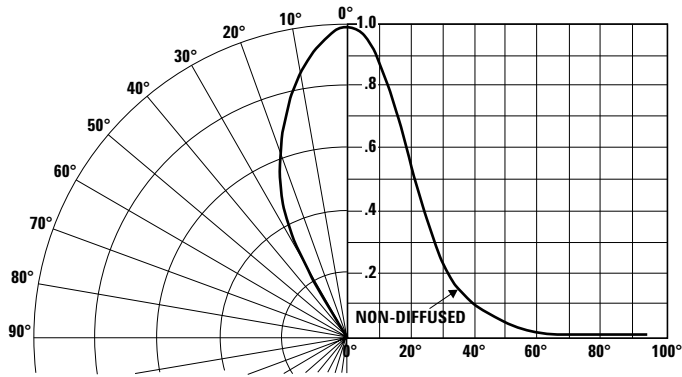

Figure 16. Relative luminous intensity vs. angular displacement.

Intensity Bin Limits

| Color | Bin | Intensity Range (mcd) | |
|--------|---------|-----------------------|---------|
| | | Min. | Max. |
| Red | G | 9.7 | 15.5 |
| | H | 15.5 | 24.8 |
| | I | 24.8 | 39.6 |
| | J | 39.6 | 63.4 |
| | K | 63.4 | 101.5 |
| | L | 101.5 | 162.4 |
| | M | 162.4 | 234.6 |
| | N | 234.6 | 340.0 |
| | O | 340.0 | 540.0 |
| | P | 540.0 | 850.0 |
| | Q | 850.0 | 1200.0 |
| | R | 1200.0 | 1700.0 |
| | S | 1700.0 | 2400.0 |
| | T | 2400.0 | 3400.0 |
| | U | 3400.0 | 4900.0 |
| | V | 4900.0 | 7100.0 |
| | W | 7100.0 | 10200.0 |
| | X | 10200.0 | 14800.0 |
| | Y | 14800.0 | 21400.0 |
| | Z | 21400.0 | 30900.0 |
| Yellow | F | 10.3 | 16.6 |
| | G | 16.6 | 26.5 |
| | H | 26.5 | 42.3 |
| | I | 42.3 | 67.7 |
| | J | 67.7 | 108.2 |
| | K | 108.2 | 173.2 |
| | L | 173.2 | 250.0 |
| | M | 250.0 | 360.0 |
| | N | 360.0 | 510.0 |
| | O | 510.0 | 800.0 |
| | P | 800.0 | 1250.0 |
| | Q | 1250.0 | 1800.0 |
| | R | 1800.0 | 2900.0 |
| | S | 2900.0 | 4700.0 |
| | T | 4700.0 | 7200.0 |
| | U | 7200.0 | 11700.0 |
| V | 11700.0 | 18000.0 | |
| W | 18000.0 | 27000.0 | |

Intensity Bin Limits

| Color | Bin | Intensity Range (mcd) | |
|-------|---------|-----------------------|---------|
| | | Min. | Max. |
| Green | E | 7.6 | 12.0 |
| | F | 12.0 | 19.1 |
| | G | 19.1 | 30.7 |
| | H | 30.7 | 49.1 |
| | I | 49.1 | 78.5 |
| | J | 78.5 | 125.7 |
| | K | 125.7 | 201.1 |
| | L | 201.1 | 289.0 |
| | M | 289.0 | 417.0 |
| | N | 417.0 | 680.0 |
| | O | 680.0 | 1100.0 |
| | P | 1100.0 | 1800.0 |
| | Q | 1800.0 | 2700.0 |
| | R | 2700.0 | 4300.0 |
| | S | 4300.0 | 6800.0 |
| | T | 6800.0 | 10800.0 |
| U | 10800.0 | 16000.0 | |
| V | 16000.0 | 25000.0 | |
| W | 25000.0 | 40000.0 | |

Maximum tolerance for each bin limit is $\pm 18\%$.

Color Categories

| Color | Category # | Lambda (nm) | |
|--------|------------|-------------|-------|
| | | Min. | Max. |
| Green | 6 | 561.5 | 564.5 |
| | 5 | 564.5 | 567.5 |
| | 4 | 567.5 | 570.5 |
| | 3 | 570.5 | 573.5 |
| | 2 | 573.5 | 576.5 |
| Yellow | 1 | 582.0 | 584.5 |
| | 3 | 584.5 | 587.0 |
| | 2 | 587.0 | 589.5 |
| | 4 | 589.5 | 592.0 |
| | 5 | 592.0 | 593.0 |

Maximum tolerance for each bin limit is ± 0.5 nm.

Mechanical Option Matrix

| Mechanical Option Code | Definition |
|------------------------|--|
| 00 | Bulk Packaging, minimum increment 500 pcs/bag |
| 01 | Tape & Reel, crimped leads, minimum increment 1800 pcs/bag |
| 02 | Tape & Reel, straight leads, minimum increment 1800 pcs/bag |
| A1 | Right Angle Housing, uneven leads, minimum increment 500 pcs/bag |
| A2 | Right Angle Housing, even leads, minimum increment 500 pcs/bag |

Note:

All categories are established for classification of products. Products may not be available in all categories. Please contact your local Avago representative for further clarification/information.

Precautions:

Lead Forming

- The leads of an LED lamp may be preformed or cut to length prior to insertion and soldering into PC board.
- If lead forming is required before soldering, care must be taken to avoid any excessive mechanical stress induced to LED package. Otherwise, cut the leads of LED to length after soldering process at room temperature. The solder joint formed will absorb the mechanical stress of the lead cutting from traveling to the LED chip die attach and wirebond.
- It is recommended that tooling made to precisely form and cut the leads to length rather than rely upon hand operation.

Soldering Conditions

- Care must be taken during PCB assembly and soldering process to prevent damage to LED component.
- The closest LED is allowed to solder on board is 1.59 mm below the body (encapsulant epoxy) for those parts without standoff.
- Recommended soldering conditions:

| | Wave Soldering | Manual Solder Dipping |
|----------------------|----------------|-----------------------|
| Pre-heat Temperature | 105°C Max. | – |
| Pre-heat Time | 30 sec Max. | – |
| Peak Temperature | 250°C Max. | 260°C Max. |
| Dwell Time | 3 sec Max. | 5 sec Max. |

- Wave soldering parameter must be set and maintained according to recommended temperature and dwell time in the solder wave. Customer is advised to periodically check on the soldering profile to ensure the soldering profile used is always conforming to recommended soldering condition.
- If necessary, use fixture to hold the LED component in proper orientation with respect to the PCB during soldering process.
- Proper handling is imperative to avoid excessive thermal stresses to LED components when heated. Therefore, the soldered PCB must be allowed to cool to room temperature, 25°C, before handling.
- Special attention must be given to board fabrication, solder masking, surface plating and lead holes size and component orientation to assure solderability.
- Recommended PC board plated through hole sizes for LED component leads:

| LED Component Lead Size | Diagonal | Plated Through Hole Diameter |
|--|--------------------------|--|
| 0.457 x 0.457 mm (0.018 x 0.018 inch) | 0.646 mm (0.025 inch) | 0.976 to 1.078 mm (0.038 to 0.042 inch) |
| 0.508 x 0.508 mm (0.020 x 0.020 inch) | 0.718 mm (0.028 inch) | 1.049 to 1.150 mm (0.041 to 0.045 inch) |

Note: Refer to application note AN1027 for more information on soldering LED components.

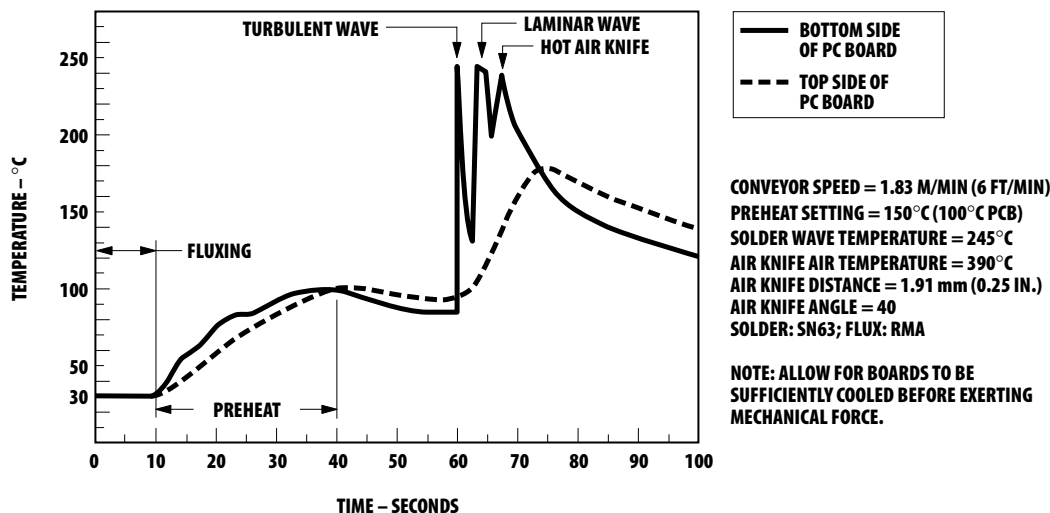

Figure 17. Recommended wave soldering profile.

For product information and a complete list of distributors, please go to our website: www.avagotech.com



Компания «ЭлектроПласт» предлагает заключение долгосрочных отношений при поставках импортных электронных компонентов на взаимовыгодных условиях!

Наши преимущества:

- Оперативные поставки широкого спектра электронных компонентов отечественного и импортного производства напрямую от производителей и с крупнейших мировых складов;
- Поставка более 17-ти миллионов наименований электронных компонентов;
- Поставка сложных, дефицитных, либо снятых с производства позиций;
- Оперативные сроки поставки под заказ (от 5 рабочих дней);
- Экспресс доставка в любую точку России;
- Техническая поддержка проекта, помощь в подборе аналогов, поставка прототипов;
- Система менеджмента качества сертифицирована по Международному стандарту ISO 9001;
- Лицензия ФСБ на осуществление работ с использованием сведений, составляющих государственную тайну;
- Поставка специализированных компонентов (Xilinx, Altera, Analog Devices, Intersil, Interpoint, Microsemi, Aeroflex, Peregrine, Syfer, Eurofarad, Texas Instrument, Miteq, Cobham, E2V, MA-COM, Hittite, Mini-Circuits, General Dynamics и др.);

Помимо этого, одним из направлений компании «ЭлектроПласт» является направление «Источники питания». Мы предлагаем Вам помощь Конструкторского отдела:

- Подбор оптимального решения, техническое обоснование при выборе компонента;
- Подбор аналогов;
- Консультации по применению компонента;
- Поставка образцов и прототипов;
- Техническая поддержка проекта;
- Защита от снятия компонента с производства.



Как с нами связаться

Телефон: 8 (812) 309 58 32 (многоканальный)

Факс: 8 (812) 320-02-42

Электронная почта: org@eplast1.ru

Адрес: 198099, г. Санкт-Петербург, ул. Калинина, дом 2, корпус 4, литера А.