



## MHR-V SERIES

### Miniature Vented Case, High Temperature AC LVDT

#### SPECIFICATIONS

- ◆ Vented case for submersed applications
- ◆ Operating pressure up to 10,000 PSI
- ◆ Operating temperature 392°F [200°C]
- ◆ Small size and low mass core
- ◆ High output signal
- ◆ Stroke ranges from  $\pm 0.025$  to  $\pm 1$  inch
- ◆ AC operation from 2kHz to 20kHz
- ◆ Stainless steel housing
- ◆ Imperial or metric threaded core

The **MHR-V** Series LVDTs are a variant of the legendary MHR Series. The MHR-V is specifically designed for submersion in inert gas, mineral oil, and other non-aggressive oils (consult factory for medium compatibility) under pressures up to 10,000 PSI [700 bars].

With a diameter of just 3/8 inch [9.5mm], the MHR-V Series allow precision measurements in space restrictive installations at temperatures up to 392°F [200°C]. The extremely lightweight core makes the MHR-V an excellent choice for applications where excessive core weight could influence the motion; with less inertia, accurate measurements at higher displacement speeds are easier to achieve. The lightweight core also reduces mechanical stresses and helps preserve the structural integrity of the core actuation assembly.

The high output sensitivity resulting from the close electrical coupling between the coil and core provides ample signal for interfacing with practically all signal conditioners and conditioning circuits. The magnetic stainless steel housing provides electromagnetic and electrostatic shielding.

Available in a variety of stroke ranges from  $\pm 0.025$  to  $\pm 1$  inch, the MHR-V is compatible with the full line of Measurement Specialties LVDT signal conditioners.

#### FEATURES

- ◆ Compact size
- ◆ 10,000 PSI equipressure operation
- ◆ 392°F [200°C] continuous operation
- ◆ Lightweight core
- ◆ Stainless steel case
- ◆ Calibration certificate supplied with each unit

#### APPLICATIONS

- ◆ Immersion applications (oils, inert gasses)
- ◆ Subsea Oil & Gas equipment
- ◆ Down-hole tools and oil drilling equipment
- ◆ Hydrostatic test chambers
- ◆ Hydraulic spool valve feedback
- ◆ Automotive transmission servo testing

**PERFORMANCE SPECIFICATIONS**

<b>ELECTRICAL SPECIFICATIONS (common)</b>						
Input voltage	3 VRMS sine wave					
Input frequency	2kHz to 20kHz					
Test frequency	2.5kHz (standard)					
<b>ELECTRICAL SPECIFICATIONS @ 10kHz (recommended operation)</b>						
Parameter	MHR-V 025	MHR-V 050	MHR-V 100	MHR-V 250	MHR-V 500	MHR-V 1000
Stroke range	±0.025 [±0.64]	±0.05 [±1.27]	±0.10 [±2.54]	±0.25 [±6.35]	±0.5 [±12.7]	±1 [±25.4]
Sensitivity, V/V/inch [mV/V/mm]	8.10 [319]	3.15 [124]	2.80 [110]	2.07 [81.5]	1.96 [77.2]	0.77 [30.3]
Output at stroke ends, mV/V (*)	202.5	157.5	280	517.5	980	770
Phase shift	+21°	+8°	+5°	+7°	+7°	-1°
Input impedance (PRIMARY)	238Ω	419Ω	400Ω	345Ω	264Ω	155Ω
Output impedance (SECONDARY)	485Ω	154Ω	200Ω	420Ω	810Ω	450Ω
Non-linearity	±% of FR					
@ 50% stroke	0.15	0.15	0.15	0.15	0.15	0.20
<b>@100% stroke (maximum)</b>	<b>0.25</b>	<b>0.25</b>	<b>0.25</b>	<b>0.25</b>	<b>0.25</b>	<b>0.25</b>
@125% stroke	0.25	0.35	0.25	0.35	0.30 (**)	0.50
@150% stroke	0.30	0.50	0.30	0.50 (**)	0.75 (**)	/
Null voltage (max.)	0.5% of FSO					

<b>ELECTRICAL SPECIFICATIONS @ 2.5kHz (standard calibration)</b>						
Parameter	MHR-V 025	MHR-V 050	MHR-V 100	MHR-V 250	MHR-V 500	MHR-V 1000
Stroke range	±0.025 [±0.64]	±0.05 [±1.27]	±0.10 [±2.54]	±0.25 [±6.35]	±0.5 [±12.7]	±1 [±25.4]
Sensitivity, V/V/in [mV/V/mm]	4.36 [172]	2.55 [100]	2.40 [94]	1.73 [68]	1.60 [63]	0.70 [27]
Output at 100% stroke, mV/V (*)	109	127.5	240	432.5	800	700
Phase shift	+58°	+36°	+30°	+33°	+23°	+6°
Input impedance (PRIMARY)	116Ω	141Ω	135Ω	147Ω	145Ω	100Ω
Output impedance (SECONDARY)	286Ω	90Ω	125Ω	268Ω	445Ω	370Ω
Non-linearity	±% of FR					
@ 50% stroke	0.15	0.15	0.15	0.15	0.15	0.20
<b>@100% stroke (maximum)</b>	<b>0.25</b>	<b>0.25</b>	<b>0.25</b>	<b>0.25</b>	<b>0.25</b>	<b>0.25</b>
@125% stroke	0.25	0.35	0.25	0.35	0.30 (**)	0.50
@150% stroke	0.30	0.50	0.30	0.50 (**)	0.75 (**)	/
Null voltage (max)	0.5% of FSO					

<b>ENVIRONMENTAL SPECIFICATIONS &amp; MATERIALS</b>	
Operating temperature	-4°F to +392°F [-20°C to +200°C]
Operating pressure	Up to 10,000 PSI [700 bars]; <b>maximum slew rate 1,000 PSI [70 bars] per minute (***)</b>
Housing material	AISI 400 Series stainless steel
Electrical connection	Six lead-wires, 32 AWG stranded plated Copper, PTFE insulated, 3 foot [1 meter] long

**Notes:**

All values are nominal unless otherwise noted

Electrical specifications are for the test frequency indicated in the table

Dimensions are in inch [mm] unless otherwise noted

FR: Full Range is the stroke range, end to end; FR=2xS for ±S stroke range

FSO (Full Scale Output): Largest absolute value of the outputs measured at the ends of the range

(\*) Unit for output at stroke ends is millivolt per volt of excitation (input voltage)

(\*\*) Requires special reduced core length

(\*\*\*) Do not increase or decrease pressure faster than 1,000 PSI [70 bars] per minute to avoid permanent damage



# MHR-T SERIES

Miniature High-Temperature AC LVDT

## MECHANICAL SPECIFICATIONS

Parameter	MHR-V 025	MHR-V 050	MHR-V 100	MHR-V 250	MHR-V 500	MHR-V 1000
Body length "A"	0.660 [16.8]	0.815 [20.7]	0.990 [25.1]	1.850 [47.0]	3.300 [83.82]	5.600 [142.2]
Core length "B"	0.400 [10.2]	0.500 [12.7]	0.625 [15.9]	1.125 [28.6]	2.000 [50.8]	3.000 [76.2]
Housing vent hole diameter "C"	0.063 [1.60]	0.063 [1.60]	0.063 [1.60]	0.063 [1.60]	0.063 [1.60]	0.063 [1.60]
Vent hole spacing "D"	0.20 [5.1] to 0.28 [7.1]	0.27 [6.9]	0.33 [8.4]	0.46 [11.7]	0.825 [21.0]	0.80 [20.3]
Number of vent holes per row "E"	2	2	2	3	3	6
Number of hole rows around housing "F"	4	4	4	3	3	3
Body weight, oz [g]	0.18 [5]	0.21 [6]	0.21 [6]	0.32 [9]	0.60 [17]	0.92 [26]
Core weight, oz [g]	0.016 [0.5]	0.016 [0.5]	0.025 [0.7]	0.032 [0.9]	0.056 [1.6]	0.088 [2.5]

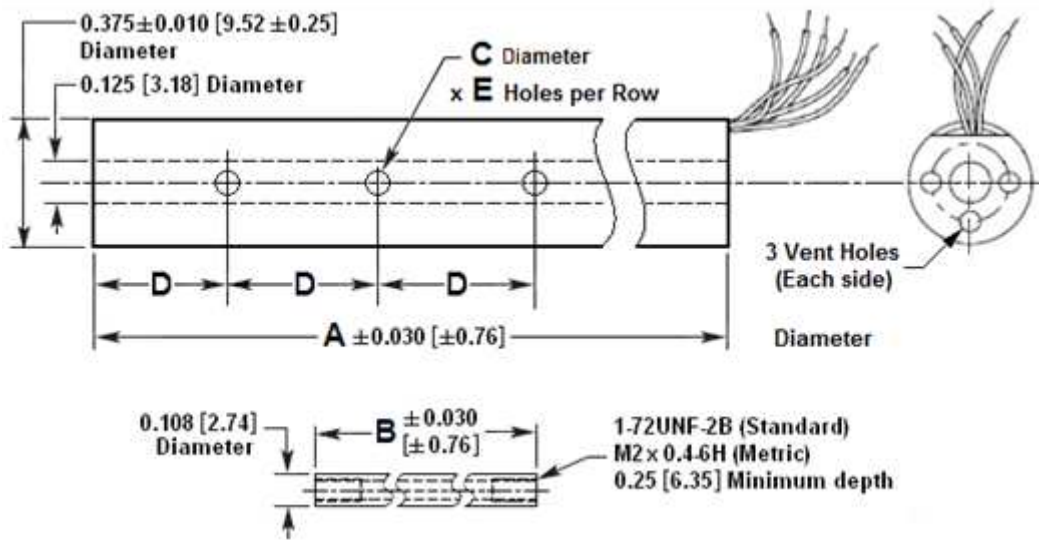

Dimensions are in inch [mm]

## WIRING INFORMATION

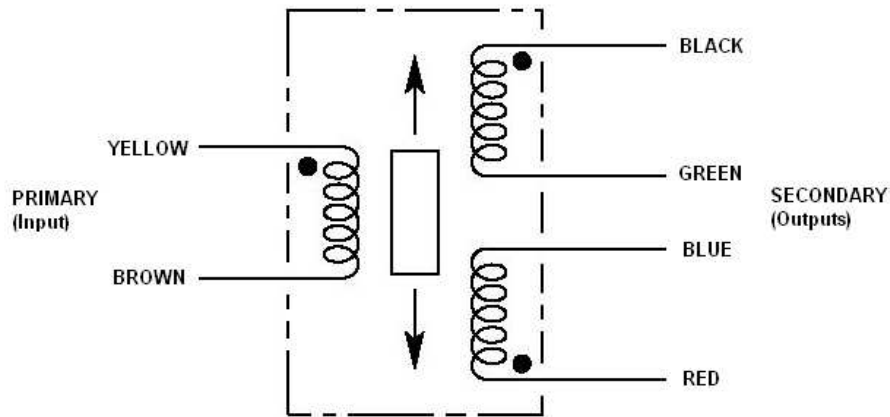

Connect Blue to Green for differential output

## MHR-T SERIES

Miniature High-Temperature AC LVDT

### ORDERING INFORMATION

Description	Model	Part Number
±0.025 inch LVDT	MHR-V 025	02564407-000
±0.05 inch LVDT	MHR-V 050	02564408-000
±0.10 inch LVDT	MHR-V 100	02564409-000

Description	Model	Part Number
±0.25 inch LVDT	MHR-V 250	02564410-000
±0.5 inch LVDT	MHR-V 500	02564411-000
±1 inch LVDT	MHR-V 1000	02564412-000

#### OPTIONS AND ACCESSORIES

OPTIONS AND ACCESSORIES	
Metric threaded core (use base part numbers from above)	XXXXXXXX-006
Core connecting rod, 6 inches long, 1-72 threads	05282945-006
Core connecting rod, 12 inches long, 1-72 threads	05282945-012
Core connecting rod, 24 inches long, 1-72 threads	05282945-024
Core connecting rod, 36 inches long, 1-72 threads	05282945-036
Core connecting rod, 6 inches long, M2x0.4 metric threads	05282976-006
Core connecting rod, 12 inches long, M2x0.4 metric threads	05282976-012

#### NORTH AMERICA

Measurement Specialties, Inc.,  
a TE Connectivity company  
Tel: 800-522-6752  
Email: [customercare.frm@te.com](mailto:customercare.frm@te.com)

#### EUROPE

Measurement Specialties (Europe), Ltd.,  
a TE Connectivity Company  
Tel: 800-440-5100  
Email: [customercare.bevx@te.com](mailto:customercare.bevx@te.com)

#### ASIA

Measurement Specialties (China) Ltd.,  
a TE Connectivity company  
Tel: 0400-820-6015  
Email: [customercare.shzn@te.com](mailto:customercare.shzn@te.com)

[TE.com/sensorsolutions](http://TE.com/sensorsolutions)

Measurement Specialties, Inc., a TE Connectivity company.

Measurement Specialties, TE Connectivity, TE Connectivity (logo) and EVERY CONNECTION COUNTS are trademarks. All other logos, products and/or company names referred to herein might be trademarks of their respective owners.

The information given herein, including drawings, illustrations and schematics which are intended for illustration purposes only, is believed to be reliable. However, TE Connectivity makes no warranties as to its accuracy or completeness and disclaims any liability in connection with its use. TE Connectivity's obligations shall only be as set forth in TE Connectivity's Standard Terms and Conditions of Sale for this product and in no case will TE Connectivity be liable for any incidental, indirect or consequential damages arising out of the sale, resale, use or misuse of the product. Users of TE Connectivity products should make their own evaluation to determine the suitability of each such product for the specific application.

© 2015 TE Connectivity Ltd. family of companies All Rights Reserved.



Компания «ЭлектроПласт» предлагает заключение долгосрочных отношений при поставках импортных электронных компонентов на взаимовыгодных условиях!

Наши преимущества:

- Оперативные поставки широкого спектра электронных компонентов отечественного и импортного производства напрямую от производителей и с крупнейших мировых складов;
- Поставка более 17-ти миллионов наименований электронных компонентов;
- Поставка сложных, дефицитных, либо снятых с производства позиций;
- Оперативные сроки поставки под заказ (от 5 рабочих дней);
- Экспресс доставка в любую точку России;
- Техническая поддержка проекта, помощь в подборе аналогов, поставка прототипов;
- Система менеджмента качества сертифицирована по Международному стандарту ISO 9001;
- Лицензия ФСБ на осуществление работ с использованием сведений, составляющих государственную тайну;
- Поставка специализированных компонентов (Xilinx, Altera, Analog Devices, Intersil, Interpoint, Microsemi, Aeroflex, Peregrine, Syfer, Eurofarad, Texas Instrument, Miteq, Cobham, E2V, MA-COM, Hittite, Mini-Circuits, General Dynamics и др.);

Помимо этого, одним из направлений компании «ЭлектроПласт» является направление «Источники питания». Мы предлагаем Вам помощь Конструкторского отдела:

- Подбор оптимального решения, техническое обоснование при выборе компонента;
- Подбор аналогов;
- Консультации по применению компонента;
- Поставка образцов и прототипов;
- Техническая поддержка проекта;
- Защита от снятия компонента с производства.



#### Как с нами связаться

**Телефон:** 8 (812) 309 58 32 (многоканальный)

**Факс:** 8 (812) 320-02-42

**Электронная почта:** [org@eplast1.ru](mailto:org@eplast1.ru)

**Адрес:** 198099, г. Санкт-Петербург, ул. Калинина, дом 2, корпус 4, литера А.