

MLX90366 Triaxis® Position Sensor IC

Datasheet

Features and Benefits

- Absolute Rotary & Linear Position Sensor IC
- **Triaxis®** Hall Technology
- Simple Magnetic Design
- Programmable Transfer Characteristic (Multi-Points – Piece-Wise-Linear)
- SENT output (according to SAE J2716-2010)
- 12 bit Resolution - 10 bit Thermal Accuracy
- On Board Diagnostics
- Over-Voltage Protection, under-Voltage Detection
- 48 bit ID Number option
- Automotive Temperature Range
- AEC-Q100 Qualified
- Reliable NoPCB Module Integration
- DMP-4 RoHS Compliant
- Output Thermal Offset correction



DMP-4

Applications

- Absolute Rotary Position Sensor
- Absolute Linear Position Sensor
- Pedal Position Sensor
- Steering Wheel Position Sensor
- Throttle Position Sensor
- Float-Level Sensor
- Ride Height Position Sensor
- Non-Contacting Potentiometer

Description

The MLX90366 is a monolithic sensor IC sensitive to the flux density applied orthogonally and parallel to the IC surface.

The MLX90366 is sensitive to the three components of the flux density applied to the IC (i.e. B_x , B_y and B_z). This allows the MLX90366 with the correct magnetic circuit to decode the absolute position of any moving magnet (e.g. rotary position from 0 to 360 Degrees or linear displacement, stroke). It enables the design of novel generation of non-contacting position sensors that are frequently required for both automotive and industrial applications.

MLX90366 provides SENT Frames encoded according the Throttle sensor format or Secure Sensor format. The circuit delivers enhanced serial messages providing error codes, and user-defined values.

MLX90366 Position Sensor Assembly enables the realization of position sensor modules for which a PCB is no longer needed: this yield to an increase of the electrical, mechanical and environmental robustness of the final application.



Contents

Features and Benefits.....	1
Applications.....	1
Description.....	1
1. Ordering Information	4
2. Functional Diagram	6
3. Glossary of Terms.....	6
4. Pinout.....	7
5. Absolute Maximum Ratings	7
6. Electrical Specification.....	7
7. Timing Specification.....	9
7.1. Timing diagrams.....	10
7.2. Application diagram used for rise and fall time measurement.....	11
8. Accuracy Specification	12
9. Magnetic Specification	13
10. CPU & Memory Specification.....	14
11. Traceability Information	14
12. End-User Programmable Items.....	15
13. SENT output Protocol	20
13.1. Generality.....	20
13.2. Throttle position / Single Secure Fast Channel	20
13.2.1. Frame Content.....	20
13.2.2. Diagnostic Reporting through the fast channel	21
13.3. Slow Channel.....	22
13.3.1. Enhanced Serial Message.....	22
13.3.2. Serial Message Sequence for AxU-xxx, AxV-xxx and AxX-xxx	22
13.3.3. Serial Message Sequence for ADS-xxx.....	24
13.3.4. Serial message sequence period	25
13.3.5. Serial Message Error Code	25
13.4. Start-up	26
13.5. Field sensing (ADC conversions) and the frame Synchro pulse	26

14. Description of End-User Programmable Items.....	26
14.1. Output Transfer Characteristic	26
14.1.1. CLOCKWISE Parameter	27
14.1.2. Discontinuity Point (DP or Zero Degree Point).....	27
14.1.3. 3-Pts LNR Parameters (for AxU-xxx option code only)	27
14.1.4. 17-Pts LNR Parameters (for AxV-xxx; ADS-xxx and AxX-xxx option codes).....	28
14.1.5. CLAMPING Parameters.....	29
14.1.6. Thermal Output Offset correction (for AxX-xxx option code only)	29
14.2. Identification	30
14.3. Lock (Not in ADS-xxx version).....	31
14.4. Sensor Front-End	31
14.4.1. MAPXYZ	31
14.4.2. SMISM, K and SELK Parameters	31
14.4.3. GAINMIN and GAINMAX Parameters	32
14.5. Filter	32
14.6. Diagnostic Features	33
14.7. EEPROM endurance.....	33
15. Self Diagnostic.....	33
16. Built-in Capacitors	36
17. Standard information regarding manufacturability of Melexis products with different soldering processes.....	37
18. ESD Precautions.....	37
19. Package Information.....	37
19.1. DMP-4 - Package Outline Dimensions (POD) – STD1 1.27	38
19.2. DMP-4 - Package Outline Dimensions (POD) – STD1 2.54	39
19.3. DMP-4 - Package Outline Dimensions (POD) – STD2 2.54	40
19.4. DMP-4 - Package Outline Dimensions (POD) – STD4 2.54	41
19.5. DMP-4 - Pinout and Marking.....	42
19.6. DMP-4 - Sensitive Spot Positioning.....	42
19.7. DMP-4 - Angle detection	43
20. Disclaimer.....	44
21. Contact.....	44

1. Ordering Information

Product Code	Temperature Code	Package Code	Option Code	Packing Form Code	Comment
MLX90366	L	VS	ADS-250	RE/RX	Not recommended for new design
MLX90366	L	VS	ADS-251	RE/RX	Not recommended for new design
MLX90366	L	VS	ADS-253	RE/RX	Not recommended for new design
MLX90366	L	VS	ADS-258	RE/RX	Not recommended for new design
MLX90366	L	VS	ADU-250	RE/RX	Not recommended for new design
MLX90366	L	VS	ADU-251	RE/RX	Not recommended for new design
MLX90366	L	VS	ADU-253	RE/RX	Not recommended for new design
MLX90366	L	VS	ADU-258	RE/RX	Not recommended for new design
MLX90366	L	VS	ADU-460	RE/RX	Not recommended for new design
MLX90366	L	VS	ADU-461	RE/RX	Not recommended for new design
MLX90366	L	VS	ADU-463	RE/RX	Not recommended for new design
MLX90366	L	VS	ADU-468	RE/RX	Not recommended for new design
MLX90366	L	VS	AEV-250	RE/RX	
MLX90366	L	VS	AEV-253	RE/RX	
MLX90366	L	VS	AEV-258	RE/RX	
MLX90366	L	VS	AEU-250	RE/RX	
MLX90366	L	VS	AEU-253	RE/RX	
MLX90366	L	VS	AEU-258	RE/RX	
MLX90366	L	VS	AEU-460	RE/RX	
MLX90366	L	VS	AEU-463	RE/RX	
MLX90366	L	VS	AEU-468	RE/RX	
MLX90366	L	VS	AEX-250	RE/RX	
MLX90366	L	VS	AEX-253	RE/RX	
MLX90366	L	VS	AEX-258	RE/RX	

Legend:

Temperature Code:	L: from -40 Deg.C to 150 Deg.C
Package Code:	“VS” for DMP-4 Package
Option Code:	<p>Axx-xxx: Die version ADx-xxx: Not recommended for new design AxU-xxx: Standard version with 3-Pts LNR Parameters ADS-xxx: Standard version with 17-Pts LNR Parameters AEV-xxx: Standard version with 17-Pts LNR Parameters AxX-xxx: Standard version with 17-Pts LNR Parameters and Thermal Output Offset correction</p> <p>xxx-123: 12: Capacitances configuration. See section 16 3: Trim-and-Form option</p> <ul style="list-style-type: none"> ▪ 0: Standard STD1 1.27. See section 19.1 ▪ 1: Trim-and-Form STD1 2.54. See section 19.2 ▪ 3: Trim-and-Form STD2 2.54. See section 19.3 ▪ 8: Trim-and-Form STD4 2.54. See section 19.4
Packing Form:	RE for Reel (face-up) RX for Reel (face down)
Ordering Example:	MLX90366LVS-AEX-250-RE

Table 1 – Legend

2. Functional Diagram



Figure 1 – Block Diagram

3. Glossary of Terms

Gauss (G), Tesla (T)	Units for the magnetic flux density - 1 mT = 10 G
TC	Temperature Coefficient (in ppm/Deg.C.)
NC	Not Connected
SENT	Single Edge Nibble Transmission
PWM	Pulse Width Modulation
ADC	Analog-to-Digital Converter
DAC	Digital to Analog Converter
LSB	Least Significant Bit
MSB	Most Significant Bit
DNL	Differential Non-Linearity
INL	Integral Non-Linearity
RISC	Reduced Instruction Set Computer
ASP	Analog Signal Processing
DSP	Digital Signal Processing
ATAN	Trigonometric function: arctangent (or inverse tangent)

IMC	Integrated Magneto-Concentrator (IMC®)
CoRDIC	Coordinate Rotation Digital Computer (i.e. iterative rectangular-to-polar transform)
EMC	Electro-Magnetic Compatibility
FE	Falling Edge
RE	Rising Edge
FW	Firmware
HW	Hardware
MT3V	More than 3V Condition (when $V_{DD} > 3V$ with 0.1V hysteresis)
MT4V	More than 4V Condition (when $V_{DD} < 4V$ with 0.1V hysteresis)
LSD	Low Side Driver = Open drain N
PP	Push-Pull
DMP	Dual Mold Package

Table 2 – Glossary of Terms

4. Pinout

PIN	Pin name
1	VSS (Ground)
2	VDD
3	OUT
4	VSS (Ground)

Either Vss pin can be used for grounding, but always leave 1 floating.

5. Absolute Maximum Ratings

Parameter	Value
Supply Voltage, VDD (overvoltage)	+ 24 V
Reverse Voltage Protection	– 12 V (breakdown at -14 V)
Positive Output Voltage	+ 18 V (breakdown at 24 V)
Output Current (I _{OUT})	+ 30 mA (in breakdown)
Reverse Output Voltage	– 0.3 V
Reverse Output Current	– 50 mA (in breakdown)
Operating Ambient Temperature Range, T _A	– 40 ... + 150 Deg.C
Storage Temperature Range, T _S	– 40 ... + 150 Deg.C
Magnetic Flux Density	± 1 T

Exceeding the absolute maximum ratings may cause permanent damage. Exposure to absolute maximum-rated conditions for extended periods may affect device reliability.

6. Electrical Specification

DC Operating Parameters at Nominal Supply Voltage (unless otherwise specified) and for T_A as specified by the Temperature suffix (L).

Parameter	Symbol	Test Conditions	Min	Typ	Max	Units
Nominal Supply Voltage	VDD		4.5	5	5.5	V
Supply Current ⁽¹⁾	I _{DD}	Power saving Enabled, All modes For Outmode=1		6	10 ⁽²⁾ 10 ⁽²⁾	mA
Isurge Current ⁽³⁾	I _{surge}				20	mA
Power-On reset (rising)	HPOR_LH	Refer to internal voltage V _{dig}	2	2.25	2.5	V
Power-On reset Hysteresis	HPOR_Hyst		50		200	mV
Start-up Level (rising)	MT4V_LH		3.8	4.0	4.2	V
Start-up Hysteresis	MT4V_Hyst		50		200	mV
PTC Entry Level (rising)	MT7V_LH		5.8	6.2	6.6	V
PTC Entry Level Hysteresis	MT7V_Hyst		50		200	mV
Output Short Circuit Current	I _{SHORT}	V _{out} = 0 V V _{out} = 5 V V _{out} = 18 V (T _A = 25 Deg.C)			15 15 18	mA mA mA
Output Load	R _L	Pull-down to Ground Pull-up to 5V	1 1	10 10	∞ ∞	kΩ kΩ
Active Diagnostic Output Level	Dsat_lo	Pull-up load R _L ≥ 10 kΩ to 5 V Pull-up load R _L ≥ 5 kΩ to 18V		0.5 2	2 3	%VDD
Digital Saturation Output Level	Dsat_hi	Pull-down load R _L ≥ 5 kΩ Pull-down load R _L ≥ 10 kΩ	95 97.5	97 98.5		%VDD
Passive Diagnostic Output Level (Broken Track Diagnostic) ⁽⁴⁾	BV _{ssPD}	Broken V _{ss} & Pull-down load R _L ≥ 5 kΩ Pull-down load R _L ≥ 10 kΩ	95 97.5			%VDD
	BV _{ssPU}	Broken V _{ss} & Pull-up load R _L ≥ 4.7kΩ	99.5	100		%VDD
	BV _{DDPD}	Broken V _{DD} & Pull-down load R _L ≥ 4.7kΩ		0	0.5	%VDD
	BV _{DDPU}	Broken V _{DD} & Pull-up load R _L ≥ 5kΩ			2	%VDD
Digital output Ron	R _{on}	Diag_low Diag_hi	15 120		30 300	Ohms

1 Averaged current consumption, for the dual version, the supply current is multiplied by 2.

2 To reach 10mA, the power saving option should be enabled. This option switches off and on internal blocks dynamically. It can be disabled in case of extreme emission requirements; the maximum supply current consumption is then increased up to 12mA.

3 The specified value is valid during early start-up time only; the current might dynamically exceed the specified value, shortly, during the Start-up phase.

4 For detailed information on diagnostics, see also section 15

7. Timing Specification

DC Operating Parameters at Nominal Supply Voltage (unless otherwise specified) and for T_A as specified by the Temperature suffix (L).

Parameter	Symbol	Test Conditions	Min	Typ	Max	Units
Main Clock Frequency	Ck	All contributors included thermal drift	12.6	13.3	14	MHz
Main Clock Frequency Thermal Drift	ΔTck				± 3%	Ck _{NOM}
Tick time		Default EEPROM setting		3		μs
Low pulse tick count		Exact value for Ck = 13.3 MHz The typical value will be affected by any variation of the clock	4	5		ticks
SENT Frame Period	tframe			882		μs
Internal Angle Measurement Period	tper			441		μs
First Angle Measurement to Sync Pulse latency	ta1			1084		μs
Second Angle Measurement to Sync Pulse latency	ta2			643		μs
Field Change to SENT Data : Average Latency	Latency		FILTER = 1 (recommended) SENT Transmission Included	1745		1745
SENT Frame Tick Count		Default EEPROM setting	294		294	
Watchdog	Twd		114.5	118	121.5	ms
Start-up Time (up to first sync pulse)	Tsu1			1.8		ms
Start-up Time (up to first data received)	Tsu2	Last pause pulse not included		5.9	6.3	ms
Rise Time @ Cable		Thresholds : 0.5V and 4.5V See section 9.2	2.97		5.31	μs
Rise Time @ Receiver			5.07		6.84	μs
Fall Time @ Cable			2.65		2.82	μs
Fall Time @ Receiver			4.84		4.9	μs

7.1. Timing diagrams



Figure 2 - Start-up phase timings



Figure 3 - Latencies (acquisition to output delays) – FILTER = 1 (recommended)

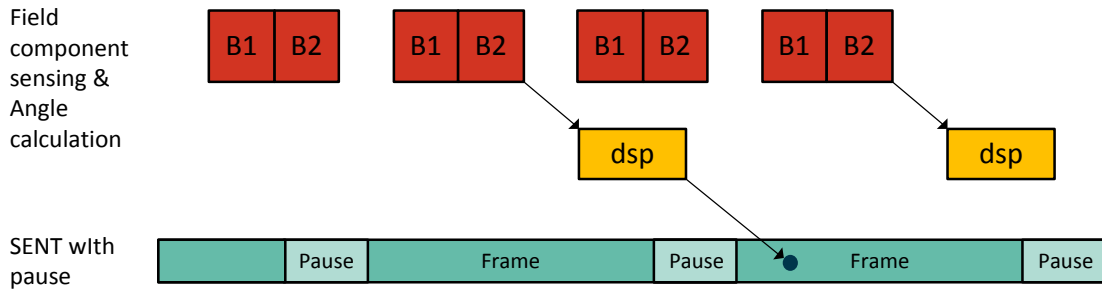

Figure 4 - Latency - Case FILTER = 0 (not recommended)



Figure 5 - Latency - Case FILTER = 2

7.2. Application diagram used for rise and fall time measurement

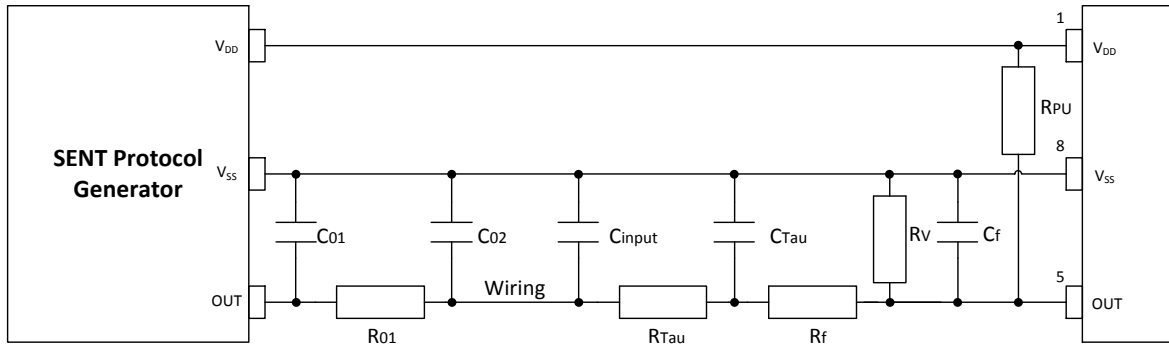

Figure 6 - Schematic used for rise and fall time measurements (ref: J2716 Rev Jan 2010 Fig. 6.3.4)

Component	Value	Unit
C01	10 ± 25%	nF
C02	not mounted	nF
R01	not mounted	Ohms
Cinput	68	pF
CTau	2.2	nF
Cf	100	pF
RTau	568	Ohms
Rf	10	kOhms
RPU	14.7	kOhms
RV	not mounted	Ohms

Component values used for rise and fall time measurements (ref: J2716 Rev Jan 2010 Fig. 6.3.4)

8. Accuracy Specification

DC Operating Parameters at Nominal Supply Voltage (unless otherwise specified) and for T_A as specified by the Temperature suffix (L).

Parameter	Symbol	Test Conditions	Min	Typ	Max	Units
ADC Resolution on the raw signals sine and cosine ⁽⁵⁾	RADC			15		bits
Thermal Offset Drift #1 ⁽⁶⁾ at the DSP input (excl. DAC and output stage)		T_A from -40 to 125°C T_A from -40 to 150°C	-60 -90		+60 +90	LSB15
Thermal Drift of Sensitivity Mismatch ⁽⁷⁾		XY axis XZ (YZ) axis	- 0.5 -1		+ 0.5 +1	%
Magnetic Angle phase error		$T_A = 25^\circ\text{C}$ – XY axis $T_A = 25^\circ\text{C}$ – XZ axis $T_A = 25^\circ\text{C}$ – YZ axis	-0.3 -2 -2		0.3 2 2	Deg.
Thermal Drift of Magnetic Angle phase error		XY axis, XZ (YZ) axis		0.01		Deg.
XY – Intrinsic Linearity Error ⁽⁸⁾	Le	$T_A = 25^\circ\text{C}$ – factory trim. “SMISM”	-1		1	Deg.
XZ - Intrinsic Linearity Error ⁽⁸⁾	Le	$T_A = 25^\circ\text{C}$ – “k” trimmed for XZ	-2.5	± 1.25	+2.5	Deg.
YZ - Intrinsic Linearity Error ⁽⁸⁾	Le	$T_A = 25^\circ\text{C}$ – “k” trimmed for YZ	-2.5	± 1.25	+2.5	Deg.
Noise pk-pk ⁽⁹⁾		Filter = 0; 40mT Filter = 1 (recommended); 30mT Filter = 2; 20mT		0.10 0.10 0.10	0.2 0.2 0.2	Deg.

5 16 bits corresponds to 15 bits + sign. Internal computation is performed using 16 bits.

6 For instance, in case of a rotary position sensor application, Thermal Offset Drift #1 equal $\pm 60\text{LSB15}$ yields to max. ± 0.3 Deg. angular error for the computed angular information (output of the DSP). This is only valid if $k = 1$.

7 For instance, in case of a rotary position sensor application, Thermal Drift of Sensitivity Mismatch equal $\pm 0.5\%$ yields to max. ± 0.15 Deg. angular error for the computed angular information (output of the DSP).

8 The Intrinsic Linearity Error refers to the IC itself (offset, sensitivity mismatch, orthogonality) taking into account an ideal rotating field for BX and BY. Once associated to a practical magnetic construction and the associated mechanical and magnetic tolerances, the output linearity error increases. However, it can be improved with the multi-point end-user calibration.

9 Noise pk-pk (peak-to-peak) is here intended as 6 times the Noise standard Deviation. The application diagram used is described in the recommended wiring. For detailed information, refer to section Filter in application mode (Section 14.5).

9. Magnetic Specification

DC Operating Parameters at Nominal Supply Voltage (unless otherwise specified) and for TA as specified by the Temperature suffix (L).

Parameter	Symbol	Test Conditions	Min	Typ	Max	Units
Magnetic Flux Density	$B_x, B_y^{(10)}$	$\sqrt{B_x^2 + B_y^2}$			70 ⁽¹¹⁾	mT
Magnetic Flux Density	B_z				126	mT
Magnetic Flux Norm	Norm	$\sqrt{B_x^2 + B_y^2 + (B_z/1.2)^2}$	20 ⁽¹²⁾			mT
IMC Gain in X and Y ⁽¹³⁾	GainIMC _{XY}		1.2	1.4	1.8	
IMC Gain in Z	GainIMC _Z		1.1		1.3	
k factor	k	GainIMC _{XY} / GainIMC _Z	1	1.2	1.5	
Magnet Temperature Coefficient	TCm		-2400		0	ppm/Deg.C

¹⁰ The condition must be fulfilled for at least one field BX or BY.

¹¹ Above 70 mT, the IMC® starts saturating yielding to an increase of the linearity error.

¹² Below 20 mT, the performances slightly degrade due to a reduction of the signal-to-noise ratio, signal-to-offset ratio.

¹³ This is the magnetic gain linked to the Integrated Magneto Concentrator structure. This is the overall variation. Within one lot, the part to part variation is typically ± 10% versus the average value of the IMC gain of that lot.

10. CPU & Memory Specification

The DSP is based on a 16 bit RISC μ Controller. This CPU provides 2.5 Mips while running at 10 MHz.

Parameter	Symbol	Test Conditions	Min	Typ	Max	Units
ROM				10		KB
RAM				384		B
EEPROM				128		B

11. Traceability Information

Every device contains a unique ID that is programmed by Melexis in the EEPROM. Melexis strongly recommends storing this value during the EOL (End-Of-Line) programming to ensure full traceability of the final product.

These parameters shall never be erased during the EOL programming.

Parameter	Comments	Default Values	Parameter # bit
MELEXISID1	Melexis identification reference	MLX	16
MELEXISID2	Melexis identification reference	MLX	16
MELEXISID3	Melexis identification reference	MLX	16

12. End-User Programmable Items

Parameter	Comments	AxU-xxx		ADS-xxx		AxV-xxx		AxX-xxx	
		#bit	Std	#bit	Std	#bit	Std	#bit	Std
MAPXYZ	Mapping fields for output angle	2	0x0	2	0x0	2	0x0	2	0x0
CLAMPHIGH	Clamping High	16	0xFF80	16	0xFFFF	16	0xFFFF	16	0xFF80
CLAMPLOW	Clamping Low	16	0x0010	16	0x0000	16	0x0000	16	0x0010
SMISM	Sensitivity mismatch factor X, Y	15	MLX	15	MLX	15	MLX	15	MLX
K	Sensitivity mismatch factor X (Y), Z	15	MLX	15	MLX	15	MLX	15	MLX
SELK	Location for K – correction	1	0x0	1	0x0	1	0x0	1	0x0
GAINMIN	Low threshold for virtual gain	8	0x00	8	0x00	8	0x00	8	0x01
GAINMAX	High threshold for virtual gain	8	0x28	8	0x28	8	0x28	8	0x28
GAINSATURATION	Gain Saturates on GAINMIX and GAINMAX	1	0x0	1	0x0	1	0x0	1	0x0
DP	Discontinuity point	15	0x0000	15	0x0000	15	0x0000	15	0x0000
CW	Clock Wise	1	0x0	1	0x0	1	0x0	1	0x0
LNRSO	3pts – Initial Slope	16	0x0000		N/A		N/A		N/A
LNRAX	3pts – AX Coordinate	16	0x0000		N/A		N/A		N/A
LNRAY	3pts – AY Coordinate	16	0x0010		N/A		N/A		N/A
LNRAS	3pts – AS Coordinate	16	0x1FF0		N/A		N/A		N/A
LNRBX	3pts – BX Coordinate	16	0xFFFF		N/A		N/A		N/A
LNRBY	3pts – BY Coordinate	16	0xFFFF		N/A		N/A		N/A
LNRBS	3pts – BS Coordinate	16	0x0000		N/A		N/A		N/A
LNRCS	3pts – CS Coordinate	16	0xFFFF		N/A		N/A		N/A

Parameter	Comments	AxU-xxx		ADS-xxx		AxV-xxx		AxX-xxx	
		#bit	Std	#bit	Std	#bit	Std	#bit	Std
LNRCY	3pts – CY Coordinate	16	0xFFFF		N/A		N/A		N/A
LNRCX	3pts – CS Coordinate	16	0x0000		N/A		N/A		N/A
DIAGSETTINGS	16 Bit Diagnostics enabling	16	0x4080	16	0xFDFF	16	0x4080	16	0x4080
CRCDISABLE	Enable EEPROM CRC check (0x0000=enabled)	16	0x0000	16	0x0000	8	0x00	8	0x00
SERIALERROR	Diagnostic reporting through fast channel	3	0x0	3	0x0	3	0x0	3	0x0
FILTER	FIR Filter	2	0x0	1	0x0	2	0x0	2	0x0
SENTSERIAL	Serial Message	8	0x80	8	0xC0	8	0x80	8	0x80
SERIAL_OEM1	Serial Message (12 lsb are used)	16	0x0000		N/A	12	0x0000	12	0x0000
SERIAL_OEM2	Serial Message (12 lsb are used)	16	0x0000		N/A	12	0x0000	12	0x0000
SERIAL_OEM3	Serial Message (12 lsb are used)	16	0x0000		N/A	12	0x0000	12	0x0000
SERIAL_OEM4	Serial Message (12 lsb are used)	16	0x0000		N/A	12	0x0000	12	0x0000
SERIAL_OEM5	Serial Message (12 lsb are used)	16	0x0000		N/A		N/A		N/A
SERIAL_OEM6	Serial Message (12 lsb are used)	16	0x0000		N/A		N/A		N/A
SERIAL_OEM7	Serial Message (12 lsb are used)	16	0x0000		N/A		N/A		N/A
SERIAL_OEM8	Serial Message (12 lsb are used)	16	0x0000		N/A		N/A		N/A
SERIAL_MANCODE	Serial Message (12 lsb are used)	16	0x0000		N/A	16	0x0000	16	0x0000
SERIAL_SensorType	Serial Message	12	0x000		N/A	12	0x000	12	0x000
SERIAL_SENTREV	Serial Message	4	0x3		N/A	4	0x3	4	0x3

Parameter	Comments	AxU-xxx		ADS-xxx		AxV-xxx		AxX-xxx	
		#bit	Std	#bit	Std	#bit	Std	#bit	Std
USERID1	Cust identification reference: Default = Bin1 Can be used as incoming inspection, only set when final test was PASS.	16	0x0001	16	0x0001		N/A		N/A
USERID2	Cust identification reference: Default Rev nr	16	0x0305	16	0x0303		N/A		N/A
USERID3	Cust identification reference: Default Sens.	16	MLX	16	MLX		N/A		N/A
SERIAL_ID1	Serial data for serial 29 (12 lsb are used)	16	0x0000		N/A	12	0x000	12	0x000
SERIAL_ID2	Serial data for serial 2A (12 lsb are used)	16	0x0000		N/A	12	0x000	12	0x000
SERIAL_ID3	Serial data for serial 2B (12 lsb are used)	16	0x0000		N/A	12	0x000	12	0x000
SERIAL_ID4	Serial data for serial 2C (12 lsb are used)	16	0x0000		N/A	12	0x000	12	0x000
SERIALID1	ID of user serial message #1		N/A	8	0x00		N/A		N/A
SERIALID2	ID of user serial message #2		N/A	8	0x00		N/A		N/A
SERIALID3	ID of user serial message #3		N/A	8	0x00		N/A		N/A
SERIALID4	ID of user serial message #4		N/A	8	0x00		N/A		N/A
SLOW_MESSAGE	Enable or disable the serial message	1	0x1		N/A	1	0x1	1	0x1
PAUSEPULSE	Enable or disable the pause pulse	1	0x1		N/A	1	0x1	1	0x1
CRC2010	CRC according 2010 or 2007 standard	1	0x1		N/A	1	0x1	1	0x1
MEMLOCK	EEPROM memory lock	2	0x0		N/A	2	0x0	2	0x0

Parameter	Comments	AxU-xxx		ADS-xxx		AxV-xxx		AxX-xxx	
		#bit	Std	#bit	Std	#bit	Std	#bit	Std
SERIALDATA1	Data of user serial message #1 (12 lsb used) Not available to USER until MemLock performed. For more details, see: EEPROM_MLX90366_default_settings.doc		N/A	16	0x56EE		N/A		N/A
SERIALDATA2	Data of user serial message #2 (12 lsb used)		N/A	16	0x0000		N/A		N/A
SERIALDATA3	Data of user serial message #3 (12 lsb used)		N/A	16	0x0000		N/A		N/A
SERIALDATA4	Data of user serial message #4 (12 lsb used)		N/A	16	0x0000		N/A		N/A
SERIAL_X1	Serial Message (12 lsb used)	16	0x0000			12	0x000	12	0x000
SERIAL_X2	Serial Message (12 lsb used)	16	0x0000			12	0x000	12	0x000
SERIAL_Y1	Serial Message (12 lsb used)	16	0x0000			12	0x000	12	0x000
SERIAL_Y2	Serial Message (12 lsb used)	16	0x0000			12	0x000	12	0x000
W	17pts – Output angle range		N/A	4	0x0	4	0x0	4	0x0
LNR0	Y coordinate point 0/16		N/A	16	0x4000	16	0x4001	16	0x4009
LNR1	Y coordinate point 1/16		N/A	16	0x4800	16	0x4801	16	0x4804
LNR2	Y coordinate point 2/16		N/A	16	0x5000	16	0x5001	16	0x5000
LNR3	Y coordinate point 3/16		N/A	16	0x5800	16	0x5801	16	0x57FC
LNR4	Y coordinate point 4/16		N/A	16	0x6000	16	0x6001	16	0x5FF8
LNR5	Y coordinate point 5/16		N/A	16	0x6800	16	0x6801	16	0x67F4
LNR6	Y coordinate point 6/16		N/A	16	0x7000	16	0x7001	16	0x6FF0

Parameter	Comments	AxU-xxx		ADS-xxx		AxV-xxx		AxX-xxx	
		#bit	Std	#bit	Std	#bit	Std	#bit	Std
LNR7	Y coordinate point 7/16		N/A	16	0x7800	16	0x7801	16	0x77EC
LNR8	Y coordinate point 8/16		N/A	16	0x8000	16	0x8001	16	0x7FE8
LNR9	Y coordinate point 9/16		N/A	16	0x8800	16	0x8801	16	0x87E4
LNR10	Y coordinate point 10/16		N/A	16	0x9000	16	0x9001	16	0x8FE0
LNR11	Y coordinate point 11/16		N/A	16	0x9800	16	0x9801	16	0x97DC
LNR12	Y coordinate point 12/16		N/A	16	0xA000	16	0xA001	16	0x8FD8
LNR13	Y coordinate point 13/16		N/A	16	0xA800	16	0xA801	16	0xA7D4
LNR14	Y coordinate point 14/16		N/A	16	0xB000	16	0xB001	16	0xAFD0
LNR15	Y coordinate point 15/16		N/A	16	0xB800	16	0xB801	16	0xB7CC
LNR16	Y coordinate point 16/16		N/A	16	0xC000	16	0xC001	16	0xBFC8
ANGLEOFSSLOPECOLD	Temperature coefficient offset at cold temperatures		N/A		N/A		N/A	8	0x0
ANGLEOFSSLOPEHOT	Temperature coefficient offset at hot temperatures		N/A		N/A		N/A	8	0x0

Melexis strongly recommends checking the User Identification data (Parameters USERID) during EOL programming.

13. SENT output Protocol

13.1. Generality

The MLX90366 complies with the sub-set of the norm J2716 Revised **JAN2010**, “A.1 Throttle Position” or “A.3 Single Secure Sensors”

13.2. Throttle position / Single Secure Fast Channel

MLX90366 delivers SENT frames according the Throttle Position (not available in ADS-xxx version) or Single Secure format.

This format is explicitly described in this section.

13.2.1. Frame Content

The MLX90366 SENT frames have 6 data nibbles, and are formatted according the below table

Single Secure									
	Nibble 0	Nibble 1	Nibble 2	Nibble 3	Nibble 4	Nibble 5	Nibble 6	Nibble 7	
SENT Frame :	Status	CH1-MSN	CH1-MidN	CH1-LSN	RC-MSN	RC-LSN	CCH1-MSN	CRC	Optional Pause
optional error code		F	F	8+EE_REPORT			0		
Status[0]	Channel 1 indicator ("1" = error, "0" otherwise)								
Status[1]	0								
Status[2]	Enhanced Serial Message (dissable option)								
Status[3]	Enhanced Serial Message (dissable option)								
CRC	Enhanced CRC (the legacy CRC is optional)								
Ch1	12 bit angle								
RC	8 bit rolling counter								
CCH1	Inverted Copy Ch1								
Throttle position									
	Nibble 0	Nibble 1	Nibble 2	Nibble 3	Nibble 4	Nibble 5	Nibble 6	Nibble 7	
SENT Frame :	Status	CH1-MSN	CH1-MidN	CH1-LSN	CH2-LSN	CH2-MidN	CH2-MSN	CRC	Optional Pause
optional error code		F	F	8+EE_REPORT	F	F	8+EE_REPORT		
Status[0]	Channel 1 indicator ("1" = error, "0" otherwise)								
Status[1]	Channel 2 indicator ("1" = error, "0" otherwise)								
Status[2]	Enhanced Serial Message (dissable option)								
Status[3]	Enhanced Serial Message (dissable option)								
CRC	Enhanced CRC (the legacy CRC is optional)								
Ch1	12 bit angle								
Ch2	12 bit angle = Inverted CH1 (optional : FFF-CH1 or FF9-CH1)								

13.2.2. Diagnostic Reporting through the fast channel

Diagnostic Reporting, bit Status[0]

The bit Status[0] is high whenever the three following conditions are met:

1. A diagnostic (analog/environmental) detects an error⁽¹⁴⁾
2. The reporting of the above error is enabled⁽¹⁵⁾
3. The debouncing time has elapsed.

Diagnostic Reporting, Channel 1

The diagnostic can be reported through the 12 bit payload of channel 1, and not only through the status bit Status[0].

The EEPROM parameters SERIALERROR controls the diagnostic reporting through channel 1 as follows:

If SERIALERROR =0, the channel 1 reports the angle, and not the diagnostic, as if no diagnostic.

The error is reported only thanks to the Status bits.

If SERIALERROR >0, the channel1 payload contains the value Channel1 = (4088 + SERIALERROR)

Diagnostic Reporting Time

The Diagnostic Reporting Time is programmable (defined as multiple of a macro-cycle unit time).

A macro-cycle is a sequence of 20 angle acquisitions, and has a duration of approximately 6 ms.

Diagnostic Debouncing

The Diagnostic Reporting is Debounced. The debouncing parameters are user-programmable, by steps of approximately 6 ms.

Pause pulse

A pause pulse, as defined by the standard, is present at the end of every frame.

The pause pulse mode can be disabled (not for ADS-xxx version). Please contact our Direct Sales team to obtain the complete procedure for deactivating the pause pulse mode.

The pause pulse length is adjusted by the circuit so that the frame period is constant.

¹⁴ A diagnostic of type digital cause the circuit to switch in fail-safe-mode

¹⁵ See EEPROM bits EE_DIAG_SETTINGS

The field sensing and the frame synchro pulse are in sync.

Fast Channel CRC

The MLX90366 features the new recommended implementation. Optionally the legacy implementation can be selected for AxU-xxx, AxV-xxx, and AxX-xxx version.

13.3. Slow Channel

13.3.1. Enhanced Serial Message

The circuit encodes the slow messages according the Enhanced Serial Message Format as specified at Chapter 5.2.4.3 of the SENT norm, except for the following restriction:

The configuration bit is always 0, meaning that the payload consists in 12-bit data and 8-bit message ID.

13.3.2. Serial Message Sequence for AxU-xxx, AxV-xxx and AxX-xxx

The circuit complies with the following sub-set specifications of the norm for pressure sensors.

(The norm for the angular sensor case does not specify the serial message format)

ID	Item	12 bit data	Comment	AxU-xxx		AxV-xxx and AxX-xxx	
				#	Optional part	#	Optional part
1	Diagnostic error codes	RAM	cf section 13.3.5	1		1	
6	SENT standard revision	Prog.	EEPROM: SERIAL_SENTREV	2		2	
1	Diagnostic error codes	RAM		3		3	
5	Manufacturer code	Prog.	EEPROM: SERIAL_MANCODE	4		4	
1	Diagnostic error codes	RAM		5		5	
3	Channel 1 / 2 sensor type	Prog.	EEPROM: SERIAL_SensorType	6		6	
1	Diagnostic error codes	RAM		7		7	
7	Fast channel 1 - X1	Prog.	EEPROM: SERIAL_X1	8		8	
1	Diagnostic error codes	RAM		9		9	
8	Fast channel 1 - X2	Prog.	EEPROM: SERIAL_X2	10		10	
1	Diagnostic error codes	RAM		11		11	
9	Fast channel 1 - Y1	Prog.	EEPROM: SERIAL_Y1	12		12	
1	Diagnostic error codes	RAM		13		13	
A	Fast channel 1 - Y2	Prog.	EEPROM: SERIAL_Y2	14		14	

ID	Item	12 bit data	Comment	AxU-xxx		AxV-xxx and AxX-xxx	
				#	Optional part	#	Optional part
1	Diagnostic error codes	RAM		15		15	
23	Temperature sensor	Prog.		16		16	
1	Diagnostic error codes	RAM		17		17	
29	Sensor ID #1	Prog.	EEPROM: SERIAL_ID1	18		18	
1	Diagnostic error codes	RAM		19		19	
2A	Sensor ID #2	Prog.	EEPROM: SERIAL_ID2	20		20	
1	Diagnostic error codes	RAM		21		21	
2B	Sensor ID #3	Prog.	EEPROM: SERIAL_ID3	22		22	
1	Diagnostic error codes	RAM		23		23	
2C	Sensor ID #4	Prog.	EEPROM: SERIAL_ID4	24		24	
1	Diagnostic error codes	RAM		25	X	25	X
90	OEM Code #1	Prog.	EEPROM: SERIAL_OEM1	26	X	26	X
1	Diagnostic error codes	RAM		27	X	27	X
91	OEM Code #2	Prog.	EEPROM: SERIAL_OEM2	28	X	28	X
1	Diagnostic error codes	RAM		29	X	29	X
92	OEM Code #3	Prog.	EEPROM: SERIAL_OEM3	30	X	30	X
1	Diagnostic error codes	RAM		31	X	31	X
93	OEM Code #4	Prog.	EEPROM: SERIAL_OEM4	32	X	32	X
1	Diagnostic error codes	RAM		33	X	N/A	
94	OEM Code #5	Prog.	EEPROM: SERIAL_OEM5	34	X	N/A	
1	Diagnostic error codes	RAM		35	X	N/A	
95	OEM Code #6	Prog.	EEPROM: SERIAL_OEM6	36	X	N/A	
1	Diagnostic error codes	RAM		37	X	N/A	
96	OEM Code #7	Prog.	EEPROM: SERIAL_OEM7	38	X	N/A	
1	Diagnostic error codes	RAM		39	X	N/A	
97	OEM Code #8	Prog.	EEPROM: SERIAL_OEM8	40	X	N/A	

Table 3 - Serial Message Sequence

The first part (positions 1 to 24) provides the Error Code and the Sensor ID alternatively. The second part is optional as a whole enabled with EEPROM bit (EE_ExtendedSequence=1). This second part consists of the error code, up to 8 OEM -defined Code.

The temperature can be derived from SENT ID 23, TEMP sensor, with the following equation:

$$\text{SENT@ ID 23} = 8 * (T[\text{C}] - 35[\text{C}]) + 865 \text{ lsb12}$$

The accuracy of the actual Temperature is around ± 10 Deg.C.

13.3.3. Serial Message Sequence for ADS-xxx

ID	Item	12 bit data	Comment	ADS-xxx	
				#	Optional part
29	Sensor ID	Prog.	EEPROM: USERID1[11:0]	1	
01	Error Code	RAM	See section 13.3.5	2	
2A	Sensor ID	Prog.	EEPROM: USERID2[7:0], USERID1[15:12]	3	
01 / 80	Error Code / User-defined RAM value	RAM	RAM variable @ address EE_RAM_PROBE_ADDR e.g. Temp, GainCode, FieldStrength	4	
2B	Sensor ID	Prog.	EEPROM: USERID3[3:0], USERID2[15:8]	5	
01	Error Code	RAM		6	
2C	Sensor ID	Prog.	EEPROM: USERID3[15:4]	7	
01 / 80	Error Code / User-defined RAM value	RAM		8	
9	06	SENT Revision	003	9	X
10	01	Error Code	RAM	10	X
11	EEPROM: SERIALID1	User-defined #1	EEPROM: SERIALDATA1	11	X
12	01 / 80	Error Code / User-defined RAM value	RAM	12	X
13	EEPROM: SERIALID2	User-defined #2	EEPROM: SERIALDATA2	13	X
14	01	Error Code	RAM	14	X
15	EEPROM: SERIALID3	User-defined #3	EEPROM: SERIALDATA3	15	X
16	01 / 80	Error Code / User-defined RAM value	RAM	16	X
17	EEPROM: SERIALID4	User-defined #4	EEPROM: SERIALDATA4	17	X
18	01	Error Code	RAM	18	X

The payloads of the positions 4, 8 (and 12, 16 if relevant) are user-defined. Three possibilities:

1. Error Code
2. 12 LSBs of a user-defined RAM value
3. 12 MSBs of a user-defined RAM value

The positions 4, 8, 12, 16 refer necessarily to the same user-defined RAM address. Three RAM addresses are of interest:

Variable name	Address	Description
ramTempSens	4E	Calibrated Temperature sensor value
VG	46	Actual Virtual Gain
Norm	48	Actual field norm

The actual absolute Temperature (T) can be derived from the 12 MSBs of ramTempSens (see possibility 3 above) using the following formula (decimal):

$$\text{ramTempSens} = 8 \times (T - 35) + 2048$$

The accuracy of the actual Temperature is around ± 10 DegC

13.3.4. Serial message sequence period

Sequence Length (serial message count)	Sequence Length (frame count)	Sequence Period (ms, typical)
8	144	121
18	324	273
24	432	381
32	576	509
40	720	636

Error Code Rate

The Error Code are on purpose transmitted every second message, to maximize the rate, which equals then 36 SENT frames.

13.3.5. Serial Message Error Code

The list of error and status messages transmitted in the 12-bit Enhanced Serial Message data field when Enhance Serial Message ID is \$01 is given in the following Table.

12 Bit Data	Diagnostic	Comments
\$000	No error	
\$801	GainOOS	Front-end Gain code Out-of-spec (too low, too high)
\$808	ADCSatura	Diag
\$810	ADCMonitor	ADC monitor
\$820	VanaMoni	Analog Internal Supply Too Low
\$840	VddMoni	External Supply Too Low
\$880	Rough Offset	Front-end Rough Offset too low, too high
\$900	TempMonitor	Temperature Sensor monitor

In case multiple errors occur, then the resulting 12 bit enhanced serial message data will be the OR-operation of the individual data values. Example \$809 = GainOOS + ADCsatura

13.4. Start-up

During the chip initialization, the output remains high until the circuit emits four initialization frames (all 6 data nibble zero). The fifth frame is not an initialization frame but a valid frame containing a measured angle. See also section 7 “Timing specifications”. The first four frames conform to the SENT specification and include a valid CRC.

13.5. Field sensing (ADC conversions) and the frame Synchro pulse

By default setting of the Timer period and Filter =1, the digital angle (fast channel payload) results of the average of two angles. These angles are themselves computed from 4 ADCs values.

The time between the ADCs and the frame synchronization pulse is constant.

As a result, the phase delay between the magnetic field angle and the SENT synchronization pulse is constant, allowing filtering at the ECU side.

See also section 7 Timing Specification.

14. Description of End-User Programmable Items

14.1. Output Transfer Characteristic

To define the transfer function (LNR):

Parameter	Comments	Value	Unit
CW	For all versions	0 → CounterClockWise 1 → ClockWise	LSB
DP	For all versions	0 ... 359.9999	Deg.
CLAMPLOW	For all versions	0 ... 100	%
CLAMPHIGH	For all versions	0 ... 100	%
LNRAX, LNRBX, LNRXC	3pts LNR only	0 ... 359.9999	Deg.
LNRAY, LNRBY, LNRCY	3pts LNR only	0 ... 100	%
LNR0, LNRAS, LNRBS, LNRCS	3pts LNR only	-17... 0 ... 17	%/Deg.
LNR0...LNR16	17pts LNR only	-50 ...+150	%
W	17pts LNR only	65.5 ... 360	Deg.
ANGLEOFSSLOPECOLD	Thermal Output Offset correction only	0..255	LSB In %/ Deg.C
ANGLEOFSSLOPEHOT	Thermal Output Offset correction only	0..255	LSB In %/ Deg.C

14.1.1. CLOCKWISE Parameter

The CLOCKWISE parameter defines the magnet rotation direction.

- CCW is defined by the 1-2-3-4 pin order direction for the Dual Mold Package.
- CW is defined by the reverse direction: 4-3-2-1 pin order direction for the Dual Mold Package.

Refer to the drawing in the sensitive spot positioning sections (Section 19.6).

14.1.2. Discontinuity Point (DP or Zero Degree Point)

The Discontinuity Point defines the 0Deg. point on the circle. The discontinuity point places the origin at any location of the trigonometric circle. The DP is used as reference for all the angular measurements.



Figure 7 - Discontinuity Point Positioning

14.1.3. 3-Pts LNR Parameters (for AxU-xxx option code only)

The LNR parameters, together with the clamping values, fully define the relation (the transfer function) between the digital angle and the output signal.

The shape of the MLX90366 transfer function from the digital angle value to the output voltage is described by the drawing below. Six segments can be programmed but the clamping levels are necessarily flat.

Two, three, or even five calibration points are then available, reducing the overall non-linearity of the IC by almost an order of magnitude each time. Three or five point calibration will be preferred by customers looking for excellent non-linearity figures. Two-point calibrations will be preferred by customers looking for a cheaper calibration set-up and shorter calibration time.



Figure 8 - 3-Pts LNR Parameters

14.1.4. 17-Pts LNR Parameters (for AxV-xxx; ADS-xxx and AxX-xxx option codes)

The LNR parameters, together with the clamping values, fully define the relation (the transfer function) between the digital angle and the output signal.

The shape of the MLX90366 transfer function from the digital angle value to the output voltage is described by the drawing below. In the 17-Pts mode, the output transfer characteristic is Piece-Wise-Linear (PWL).

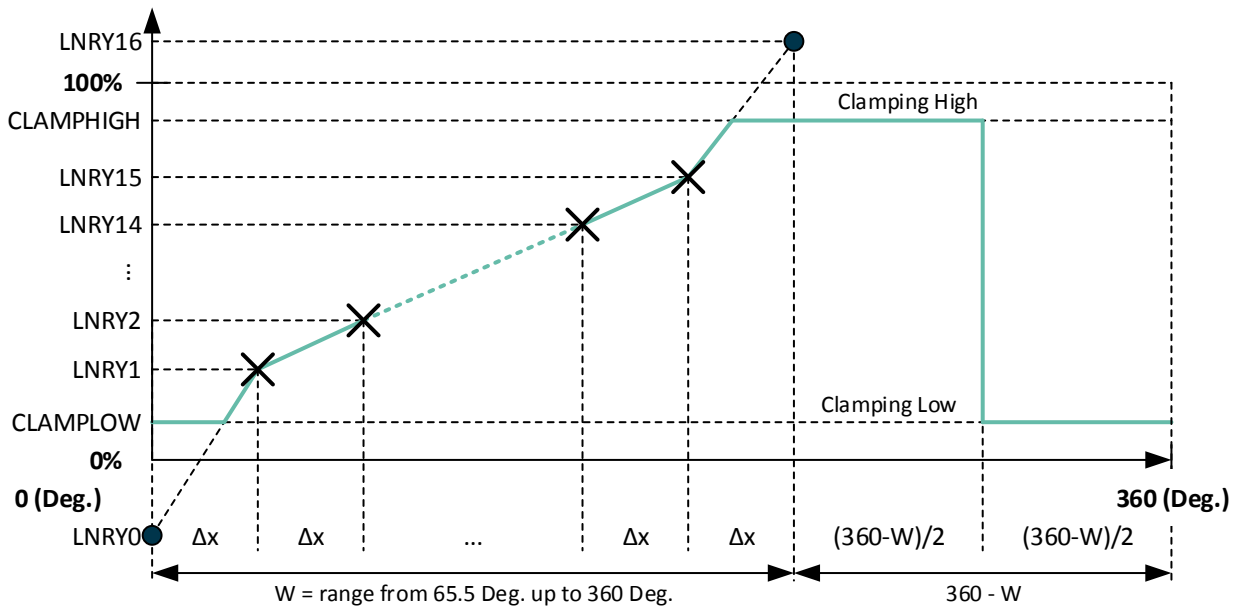

Figure 9 - Input range from 65.5Deg. up to 360Deg.

All the Y-coordinates can be programmed from -50% up to +150% to allow clamping in the middle of one segment (like on the Figure 9), but the output value is limited to CLAMPLOW and CLAMPHIGH values.

Between two consecutive points, the output characteristic is interpolated.

The parameter W determines the input range on which the 17 points (16 segments) are uniformly spread:

W	Range	Δx	W	Range	Δx
0 (0000b)	360.0Deg.	22.5Deg.	8	180.0Deg.	11.3Deg.
1	320.0Deg.	20.0Deg.	9	144.0Deg.	9.0Deg.
2	288.0Deg.	18.0Deg.	10	120.0Deg.	7.5Deg.
3	261.8Deg.	16.4Deg.	11	102.9Deg.	6.4Deg.
4	240.0Deg.	15.0Deg.	12	90.0Deg.	5.6Deg.
5	221.5Deg.	13.8Deg.	13	80.0Deg.	5.0Deg.
6	205.7Deg.	12.9Deg.	14	72.0Deg.	4.5Deg.
7	192.0Deg.	12.0Deg.	15 (1111b)	65.5Deg.	4.1Deg.

Outside of the selected range, the output will remain in clamping levels.

14.1.5. CLAMPING Parameters

The clamping levels are two independent values to limit the output voltage range. The CLAMPLOW parameter adjusts the minimum output voltage level. The CLAMPHIGH parameter sets the maximum output voltage level. Both parameters have 16 bits of adjustment and are available for both LNR modes.

14.1.6. Thermal Output Offset correction (for AxX-xxx option code only)

The two parameters ANGLEOFSSLOPEHOT and ANGLEOFSSLOPECOLD, defined in the section End-User programmable parameters see section 12, enable to add to the output, an offset depending on the measured temperature see the Figure 10.

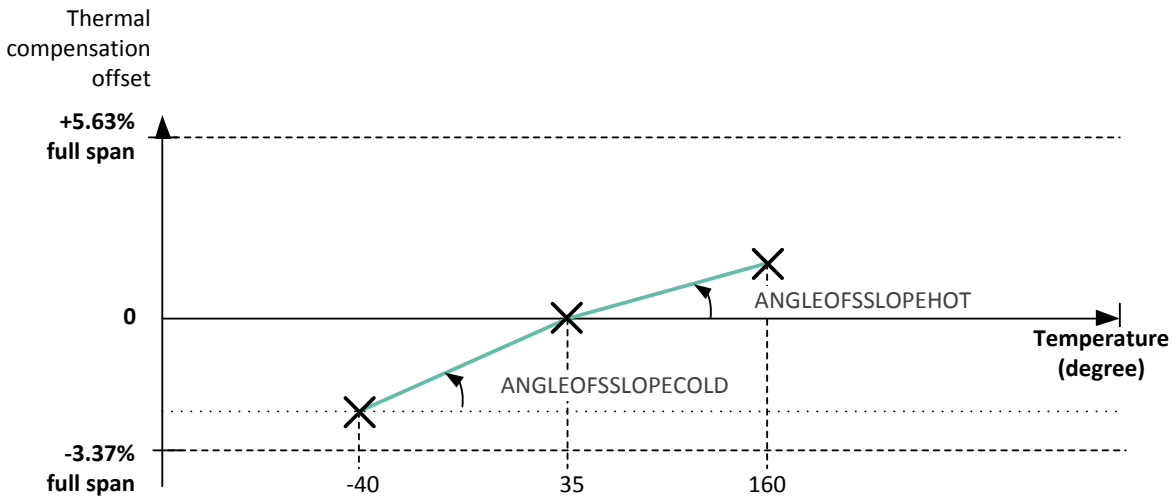

Figure 10 - Input range from -40Deg.C up to 160 Deg.C

The thermal offset is added before the clamping (see section 14.1.5). The span of this offset is +5.62/-3.37% of the full output scale. The added thermal offset varies with temperature see the equation below and the thermal coefficient is defined separately before (used coefficient ANGLEOFSSLOPECOLD) and after 35Deg.C (used coefficient ANGLEOFSSLOPEHOT).

If temperature is higher than 35Deg.C then:

$$\text{output} \leq \text{output} - \Delta T * \text{ANGLEOFSSLOPEHOT}$$

If temperature is lower than 35 Deg.C then:

$$\text{output} \leq \text{output} - \Delta T * \text{ANGLEOFSSLOPECOLD}$$

Where output is the calculated output adjusted by the thermal correction offset $\Delta T * \text{ANGLEOFSSLOPECOLD}$. Where ΔT is the difference between current temperature and reference temperature 35Deg.C. The output correction capability at hot and room (extreme temperature and maximum value of ANGLEOFSSLOPEHOT and ANGLEOFSSLOPECOLD) are given in the table below.

Parameter	min	typ	max	Unit
Output correction capability at 160Deg.C	5%	5.62%		of Full span
Output correction capability at -40Deg.C	-3.09%	-3.372%		of Full span

14.2. Identification

Parameter	Comments	Value
USERID1	For AxU-xxx and ADS-xxx versions only	0...65535
USERID2		0...65535
USERID3		0...65535

Identification number: 48 bits (3 words) freely useable by Customer for traceability purpose.

14.3. Lock (Not in ADS-xxx version)

The MEMLOCK write protects all the EEPROM parameters set by the Melexis and user. Once the lock is enabled, it is not possible to change the EEPROM values anymore.

Note that the MEMLOCK bits should be set by the solver function “MemLock”.

14.4. Sensor Front-End

Parameter	Value
MAPXYZ	0...3
SMISM	0...32768
K	0...32768
SELK	0 or 1
GAINMIN	0 ... 41
GAINMAX	0 ... 41
GAINSATURATION	0...1

14.4.1. MAPXYZ

The MAPXYZ parameter defines which fields are used to calculate the angle. The different possibilities are described in the tables below.

This 2 bits value selects the first (B1) and second (B2) field components according the table below.

MAPXYZ	B1	B2	Angular
0 – 00b	X	Y	XY mode
1 – 01b	Zx	X	XZx mode
2 – 10b	Y	Zx	YZx mode

Note: MAPXYZ = 3 is not recommended.

14.4.2. SMISM, K and SELK Parameters

(i) SMISM

When the mapping (B1=X, B2=Y) is selected, SMSIM defines the sensitivity mismatch factor that is applied on B1, B2; When another B1, B2 mapping is selected, this parameter is “don’t care”.

This parameter is trimmed at factory; Melexis strongly recommends TO NOT overwrite it for optimal performances.

(ii) K

When the mapping (B1=X, B2=Y) is **NOT** selected, K defines the sensitivity mismatch factor that is applied on B1 or B2 (according to parameter SELK – see below). When the mapping (B1=X, B2=Y) is selected, this parameter is “don’t care”.

This parameter is trimmed at factory for mapping (B1=Z, B2=X). Melexis recommends to fine trim it when a smaller linearity error (Le) is required and a different mapping than (B1=X, B2=Y) is selected.

(iii) SELK

When the mapping (B1=X, B2=Y) is **NOT** selected, SELK defines the component on which the sensitivity mismatch factor K (see above): SELK = 0 means B1 → k · B1 and SELK = 1 means B2 → k · B2.

14.4.3. GAINMIN and GAINMAX Parameters

GAINMIN and GAINMAX define the thresholds on the gain code outside which the fault “GAIN out of Spec.” is set;

If GAINSATURATION is set, then the virtual gain code is saturated at GAINMIN and GAINMAX, and no Diagnostic fault is set since the saturations applies before the diagnostic check.

14.5. Filter

Parameter	Value
FILTER	0...2

The MLX90366 features 2 FIR filter modes controlled with Filter = 1...2. Filter = 0 corresponds to no filtering. The transfer function is described below:

$$y_n = \frac{1}{\sum_{i=0}^j a_i} \sum_{i=0}^j a_i x_{n-i}$$

The filters characteristic is given in the following table:

Filter	0	1	2 (for AxU-xxx, AxV-xxx and AxX-xxx only)
J No	0	1	3
Type	Disable	Finite Impulse Response	
Coefficients ai	1	11	1111
Title	No filter	ExtraLight	Light
99% Response Time	1	2	4
Efficiency RMS (dB)	0	3.0	6.0

14.6. Diagnostic Features

It is recommended to enable the diagnostic features for safety critical applications.

Refer to Application_note_Diagnostic_Behavior_90366 for EE_CRC_Enable function description and for Diagnostic features which can be enabled by user.

14.7. EEPROM endurance

Although the EEPROM is used for Calibration Data Storage (similarly to an OTPROM), the MLX90366 embedded EEPROM is qualified to guarantee an endurance of minimum 1000 write cycles at 125°C for (engineering/calibration purpose).

15. Self Diagnostic

The MLX90366 provides numerous self-diagnostic features. Those features increase the robustness of the IC functionality as it will prevent the IC to provide erroneous output signal in case of internal or external failure modes (“fail-safe”).

Diagnostic Item	Action	Effect on Outputs	Type	Monitoring Rate	Reporting Rate
Start-up phase Diagnostics					
RAM March C-10N Test	Fail-safe mode ** ** CPU reset after 120ms	Diagnostic low/ high Reporting (optional)	Digi HW	n/applicable (start-up only)	n/applicable (start-up only)
Watchdog BIST	Fail-safe mode ** ** CPU reset after 120ms	Diagnostic low/ high Reporting (optional)	Digi HW	n/applicable (start-up only)	n/applicable (start-up only)
Under Voltage Monitoring <i>SUPPLYMONI = (MT3VB) OR (MT4VB)</i>	Start-up on Hold ** ** CPU reset after 120ms	Diagnostic low/high	Environ & Analog	n/applicable (start-up only)	n/applicable (start-up only)
Over Voltage Monitoring <i>MT7V</i>	PTC entry	Output in High-Impedance	Environ	n/applicable (start-up only)	n/applicable (start-up only)
Back-Ground Loop Diagnostics					
ROM 16bit checksum (continuous)	Fail-safe mode ** ** CPU reset after 120ms	Diagnostic low//high Reporting (optional)	Digi HW	800ms	800ms
EEPROM 8 bit CRC Check (continuous)	Fail-safe mode ** ** CPU reset after 120ms	Diagnostic low/high Reporting (optional)	Digi HW	10ms	10ms

Diagnostic Item	Action	Effect on Outputs	Type	Monitoring Rate	Reporting Rate
Watchdog (continuous)	CPU reset	--	Digi HW	120ms	n/a
DSP Loop Diagnostics					
ADC Clipping ADCCLIP	Debouncing (programmable)	SENT Status bit0 = 1 (optional)	Environ & Analog	5/DSP	$\frac{6ms \times \text{Diag_Debounce_Thresh}}{\text{Diag_Debounce_Stepup}}$
Virtual Gain Code Out-of- spec GAINOOS	Debouncing (programmable)	SENT Status bit0 = 1 (optional)	Environ & Analog	1/DSP	$\frac{6ms \times \text{Diag_Debounce_Thresh}}{\text{Diag_Debounce_Stepup}}$
Virtual Gain Code Saturation [GAINMIN..GAINMAX]	Saturation (optional)	Gain Saturated @ GAINMIN-GAINMAX	Environ & Analog	n/applicable Not a diagnostic	n/applicable Not a diagnostic
ADC Monitor (Analog to Digital Converter) ADCMONI	Debouncing (programmable)	SENT Status bit0 = 1 (optional)	Analog HW	1/DSP	$\frac{6ms \times \text{Diag_Debounce_Thresh}}{\text{Diag_Debounce_Stepup}}$
Under Voltage Monitoring SUPPLYMONI = (MT3VB) OR (MT4VB)	Supply Debouncing (programmable)	SENT Status bit0 = 1 (optional)	Environ & Analog	1/DSP	$\frac{6ms \times \text{Diag_Debounce_Thresh}}{\text{Diag_Debounce_Stepup}}$
Over Voltage Monitoring MT7V	PTC entry after PTC Debouncing	Output in High- Impedance	Environ	2ms	2ms
Temperature Sensor Monitor TEMPMONI	Debouncing (programmable)	SENT Status bit0 = 1 (optional)	Analog	1/DSP	$\frac{6ms \times \text{Diag_Debounce_Thresh}}{\text{Diag_Debounce_Stepup}}$
Temperature > 170 Deg.C (± 20) Temperature < -60 Deg.C (± 20)	Saturate value used for the compensations to -40Deg.C and +150 Deg.C resp.	No effect	Environ & Analog		n/applicable Not a diagnostic

Hardware Diagnostics (continuously checked by dedicated Logic)

Diagnostic Item	Action	Effect on Outputs	Type	Monitoring Rate	Reporting Rate
Read/Write Access out of physical memory	Fail-safe mode ** ** CPU reset after 120ms	Diagnostic Low/High	Digi HW	n/a immediate Diag	n/a immediate Diagnostic
Write Access to protected area (IO and RAM Words)	Fail-safe mode ** ** CPU reset after 120ms	Diagnostic low/high	Digi HW	n/a immediate Diag.	n/a immediate Diagnostic
Unauthorized Mode Entry	Fail-safe mode ** ** CPU reset after 120ms	Diagnostic low/high	Digi HW	n/a immediate Diag	n/a immediate Diagnostic
EEPROM Error Correcting Code (Hamming correction)	(Transparent) Error Correction	no effect	Digi HW	n/a.	n/a

Hardware Diagnostics (continuously checked by dedicated Analog circuits)

Broken VSS	CPU Reset on recovery	Pull down load => Diagnostic High Pull up load => Diagnostic High	Environ	n/a immediate Diagnostic	n/a immediate Diagnostic
Broken VDD	CPU Reset on recovery	Pull down load => Diagnostic Low Pull up load => Diagnostic Low	Environ	n/a immediate Diagnostic	n/a immediate Diagnostic
Resistive Cable Test	Start-up on Hold	Diagnostic low/high	Environ	n/a immediate Diagnostic	n/a immediate Diagnostic.

16. Built-in Capacitors

Built-in capacitors are ceramic multilayer type X8R. The capacitors are specifically suited for high temperature applications with stable capacitance value (+/- 15%) up to 150 DegC.



Ordering Code	C1	C2	C3	C4
MLX90366LVS-Axx-25x	100nF	10nF	100nF	100nF
MLX90366LVS-Axx-46x	220nF	22nF	100nF	220nF

The capacitors are assembled using a gluing method instead of soldering to be more reliable towards thermal/mechanical stress. The maximum rated voltage for the capacitors is 50V.

17. Standard information regarding manufacturability of Melexis products with different soldering processes

Our products are classified and qualified regarding soldering technology, solderability and moisture sensitivity level according to standards in place in Semiconductor industry.

For further details about test method references and for compliance verification of selected soldering method for product integration, Melexis recommends reviewing on our web site the General Guidelines soldering recommendation (<http://www.melexis.com/en/quality-environment/soldering>).

For all soldering technologies deviating from the one mentioned in above document (regarding peak temperature, temperature gradient, temperature profile etc), additional classification and qualification tests have to be agreed upon with Melexis.

For package technology embedding trim and form post-delivery capability, Melexis recommends consulting the dedicated trim&forming recommendation application note: lead trimming and forming recommendations (<http://www.melexis.com/en/documents/documentation/application-notes/lead-trimming-and-forming-recommendations>).

Melexis is contributing to global environmental conservation by promoting lead free solutions. For more information on qualifications of RoHS compliant products (RoHS = European directive on the Restriction Of the use of certain Hazardous Substances) please visit the quality page on our website: <http://www.melexis.com/en/quality-environment>.

18. ESD Precautions

Electronic semiconductor products are sensitive to Electro Static Discharge (ESD).

Always observe Electro Static Discharge control procedures whenever handling semiconductor products.

19. Package Information

19.1. DMP-4 - Package Outline Dimensions (POD) – STD1 1.27



Figure 11 – DMP-4 information for STD1 1.27 MLX90366LVS-Axx-xx0

19.2. DMP-4 - Package Outline Dimensions (POD) – STD1 2.54

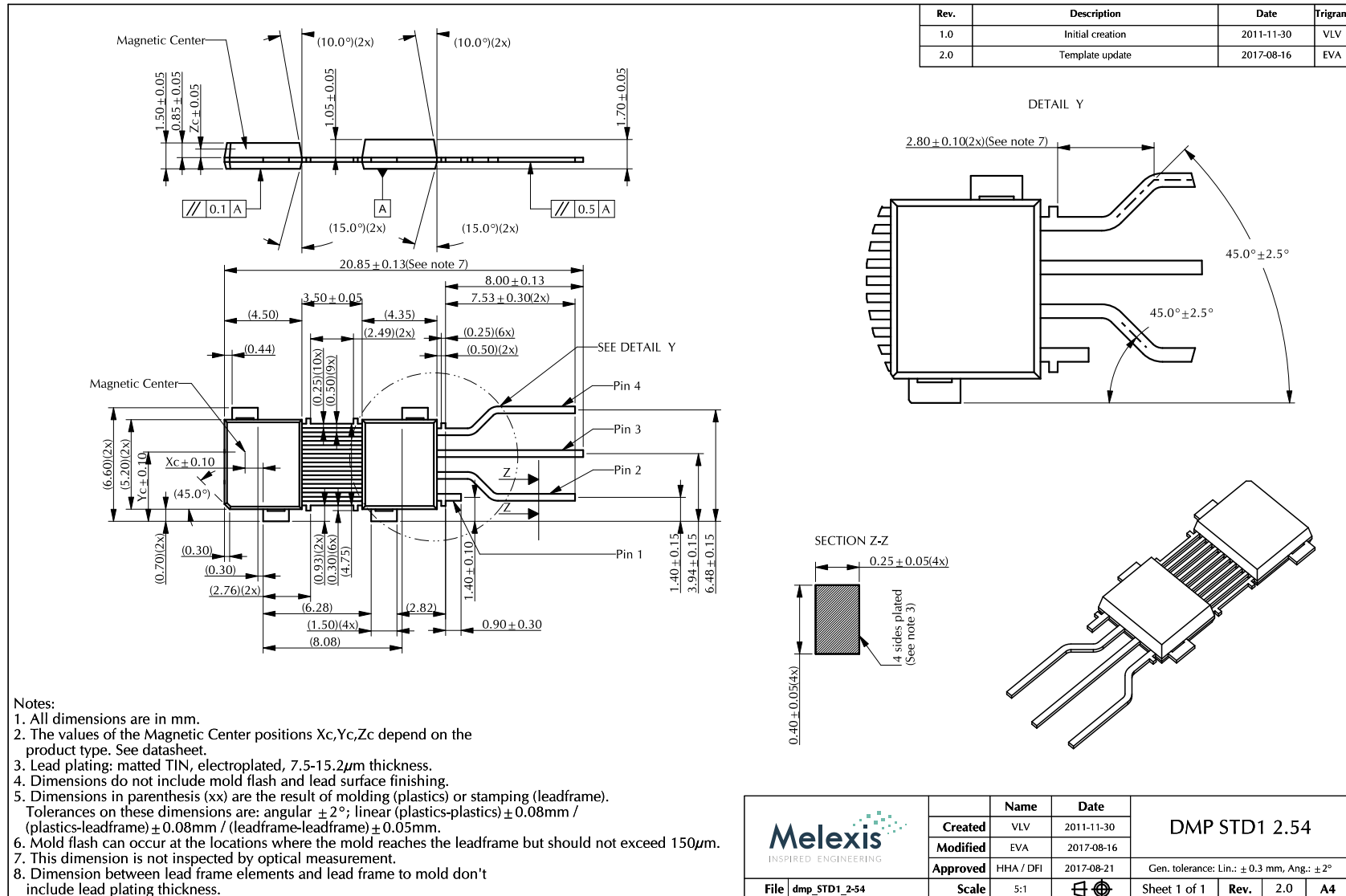

Figure 12 – DMP-4 Information for STD1 2.54 MLX90366LVS-Axx-xx1

19.3. DMP-4 - Package Outline Dimensions (POD) – STD2 2.54



Figure 13 – DMP-4 information for STD2 2.54 MLX90366LVS-Axx-xx3

19.4. DMP-4 - Package Outline Dimensions (POD) – STD4 2.54



Figure 14 – DMP-4 information for STD4 2.54 MLX90366LVS-Axx-xx8

19.5. DMP-4 - Pinout and Marking

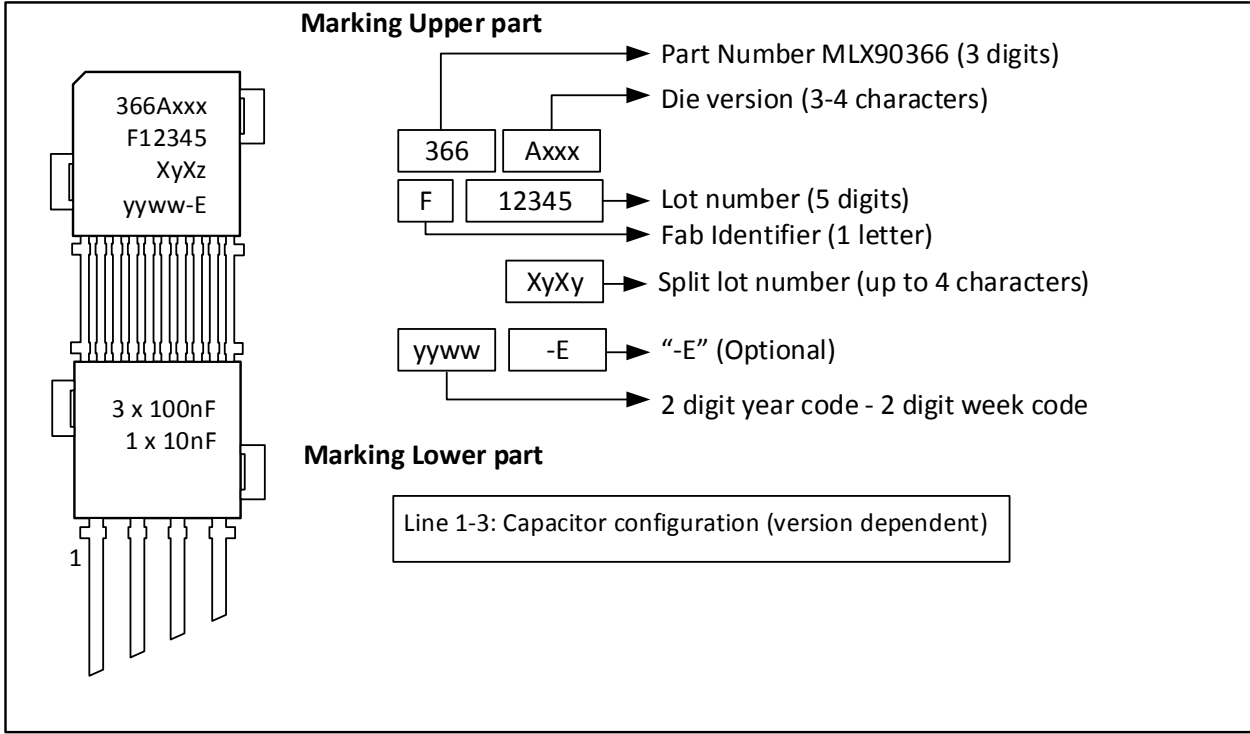

Figure 15 – DMP-4 marking and pinout convention

The pin order is indicated in sections 19.6 and 4.

19.6. DMP-4 - Sensitive Spot Positioning

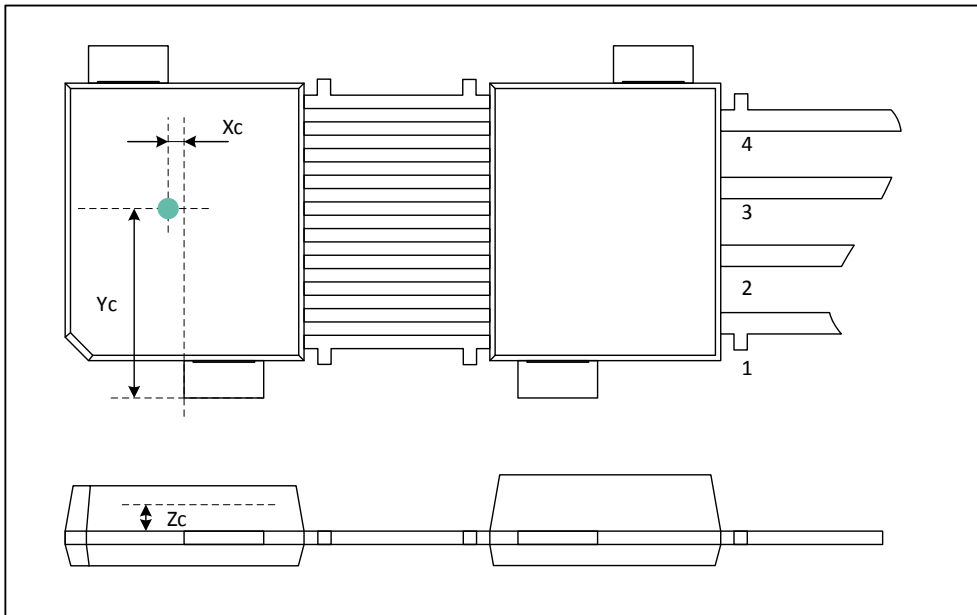

Figure 16 – DMP-4 sensitive spot positioning

Magnetic center position	Position in mm
Xc	0.23
Yc	3.67
Zc	0.495

19.7. DMP-4 - Angle detection

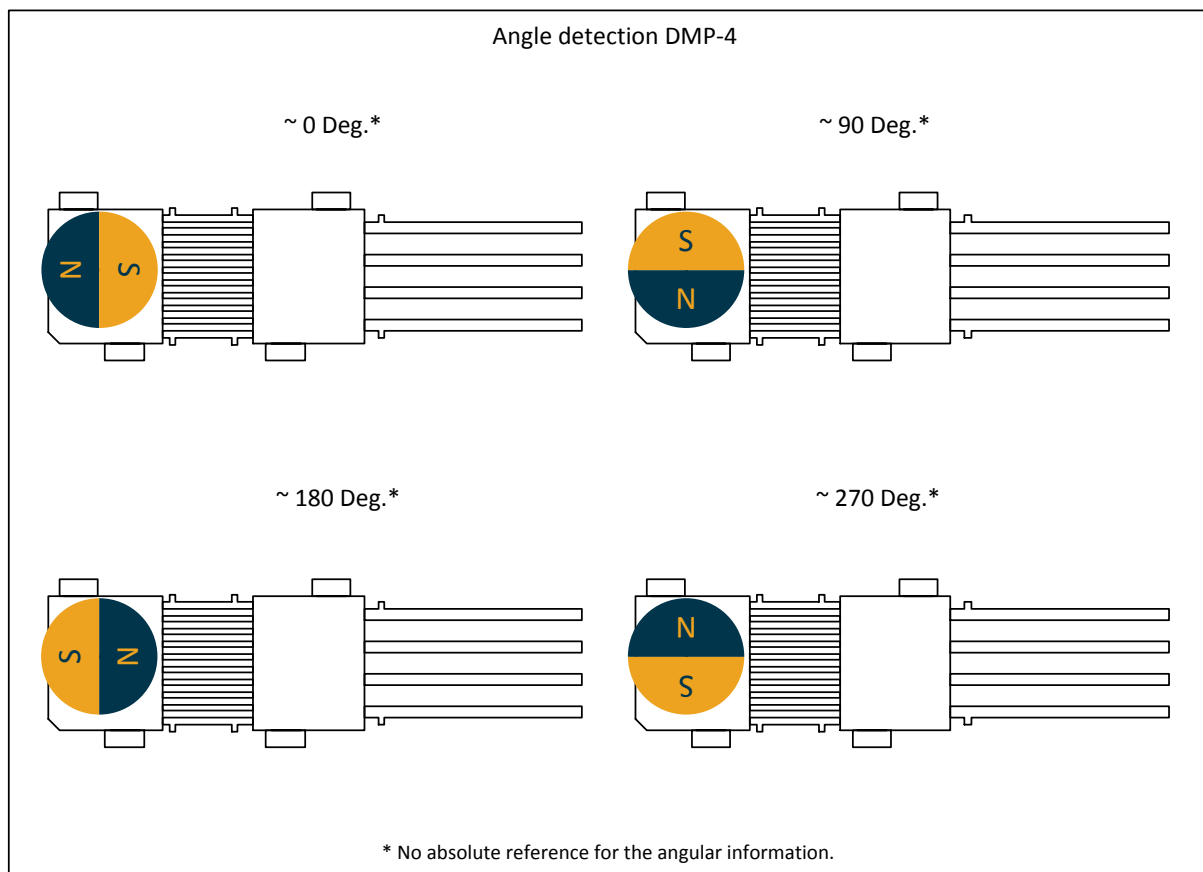

Figure 17 – DMP-4 angle detection

The MLX90366 is an absolute angular position sensor. Note however that the linearity error (See section 8) does not include the error linked to the absolute reference 0 Deg., which can be fixed in the application through the discontinuity point.

20. Disclaimer

The information furnished by Melexis herein ("Information") is believed to be correct and accurate. Melexis disclaims (i) any and all liability in connection with or arising out of the furnishing, performance or use of the technical data or use of the product(s) as described herein ("Product") (ii) any and all liability, including without limitation, special, consequential or incidental damages, and (iii) any and all warranties, express, statutory, implied, or by description, including warranties of fitness for particular purpose, non-infringement and merchantability. No obligation or liability shall arise or flow out of Melexis' rendering of technical or other services.

The Information is provided "as is" and Melexis reserves the right to change the Information at any time and without notice. Therefore, before placing orders and/or prior to designing the Product into a system, users or any third party should obtain the latest version of the relevant information to verify that the information being relied upon is current.

Users or any third party must further determine the suitability of the Product for its application, including the level of reliability required and determine whether it is fit for a particular purpose.

The Information is proprietary and/or confidential information of Melexis and the use thereof or anything described by the Information does not grant, explicitly or implicitly, to any party any patent rights, licenses, or any other intellectual property rights.

This document as well as the Product(s) may be subject to export control regulations. Please be aware that export might require a prior authorization from competent authorities.

The Product(s) are intended for use in normal commercial applications. Unless otherwise agreed upon in writing, the Product(s) are not designed, authorized or warranted to be suitable in applications requiring extended temperature range and/or unusual environmental requirements. High reliability applications, such as medical life-support or life-sustaining equipment are specifically not recommended by Melexis.

The Product(s) may not be used for the following applications subject to export control regulations: the development, production, processing, operation, maintenance, storage, recognition or proliferation of 1) chemical, biological or nuclear weapons, or for the development, production, maintenance or storage of missiles for such weapons; 2) civil firearms, including spare parts or ammunition for such arms; 3) defense related products, or other material for military use or for law enforcement; 4) any applications that, alone or in combination with other goods, substances or organisms could cause serious harm to persons or goods and that can be used as a means of violence in an armed conflict or any similar violent situation.

The Products sold by Melexis are subject to the terms and conditions as specified in the Terms of Sale, which can be found at <https://www.melexis.com/en/legal/terms-and-conditions>.

This document supersedes and replaces all prior information regarding the Product(s) and/or previous versions of this document.

Melexis NV © - No part of this document may be reproduced without the prior written consent of Melexis. (2019)

ISO/TS 16949 and ISO14001 Certified

21. Contact

For the latest version of this document, go to our website at www.melexis.com. For additional information, please contact our Direct Sales team and get help for your specific needs:

Europe, Africa	Telephone: +32 13 67 04 95 Email : sales_europe@melexis.com
Americas	Telephone: +1 603 223 2362 Email : sales_usa@melexis.com
Asia	Email : sales_asia@melexis.com



Компания «ЭлектроПласт» предлагает заключение долгосрочных отношений при поставках импортных электронных компонентов на взаимовыгодных условиях!

Наши преимущества:

- Оперативные поставки широкого спектра электронных компонентов отечественного и импортного производства напрямую от производителей и с крупнейших мировых складов;
- Поставка более 17-ти миллионов наименований электронных компонентов;
- Поставка сложных, дефицитных, либо снятых с производства позиций;
- Оперативные сроки поставки под заказ (от 5 рабочих дней);
- Экспресс доставка в любую точку России;
- Техническая поддержка проекта, помощь в подборе аналогов, поставка прототипов;
- Система менеджмента качества сертифицирована по Международному стандарту ISO 9001;
- Лицензия ФСБ на осуществление работ с использованием сведений, составляющих государственную тайну;
- Поставка специализированных компонентов (Xilinx, Altera, Analog Devices, Intersil, Interpoint, Microsemi, Aeroflex, Peregrine, Syfer, Eurofarad, Texas Instrument, Miteq, Cobham, E2V, MA-COM, Hittite, Mini-Circuits, General Dynamics и др.);

Помимо этого, одним из направлений компании «ЭлектроПласт» является направление «Источники питания». Мы предлагаем Вам помощь Конструкторского отдела:

- Подбор оптимального решения, техническое обоснование при выборе компонента;
- Подбор аналогов;
- Консультации по применению компонента;
- Поставка образцов и прототипов;
- Техническая поддержка проекта;
- Защита от снятия компонента с производства.



Как с нами связаться

Телефон: 8 (812) 309 58 32 (многоканальный)

Факс: 8 (812) 320-02-42

Электронная почта: org@eplast1.ru

Адрес: 198099, г. Санкт-Петербург, ул. Калинина, дом 2, корпус 4, литера А.