



# IAP-W420+/W422+

**Industrial outdoor IEEE 802.11 b/g/n wireless access point  
with 2x10/100Base-T(X) PoE P.D., IP-67 grade**

## Features

- High Speed Air Connectivity: WLAN interface support up to 300Mbps link speed
- Highly Security Capability: WEP/WPA/WPA-PSK(TKIP,AES)/WPA2/WPA2-PSK(TKIP,AES)/802.1X Authentication supported
- High throughput > **80Mbps**
- High power output **800mw** Max.
- Far Distance Air Connectivity up to **7 KM** (IAP-W420+)
- Support **X-Roaming** < 100 ms
- Support AP/Bridge/Client/AP-Client Mode
- Wireless connecting status monitoring
- HTTPs protocol supported for secured management
- Event Warning by Syslog, Email, SNMP Trap
- Rigid **IP-67** housing design
- Pole-mount enabled



## Introduction

IAP-W420+ / W422+ is a reliable IP-67 outdoor IEEE 802.11 b/g/n WLAN Access Point with 1 PoE P.D. Ethernet port. It can be configured to operate in AP/Bridge/AP-Client/Client mode. It is specifically designed for the toughest industrial environments. In combination with its IP-67 design and the superb management functionality, IAP-W420+ / W422+ provides a waterproof, dust-tight connection. In addition, IAP-W420+ provides high power output of 800mw and high throughput up to 80Mbps to satisfy far distance connection. IAP-W422+ provides two N-type connectors, which can install any N-type antennas to extend communication distance. You are able to configure IAP-W420+ / W422+ by WEB interface via LAN port or WLAN interface. In addition, IAP-W420+ / W422+ also provides P.D. feature which is fully compliant with IEEE802.3af PoE P.D. specification to save the layout cost of power line. The IAP-W420+ / W422+ can be easily adopted in almost all kinds of applications and provides the most rugged solutions for managing your network in outdoor. Therefore, IAP-W420+ / W422+ is one of the best outdoor communication solutions for wireless applications

## Application

In practical operation of wireless access point, Windows utility (Open-Vision) is supported. This utility is very helpful for you to search and configure IP of access point on the industrial wireless network. In addition, the wireless access point

support various kinds of operation modes include AP/ Bridge/AP-Client/Client mode. IAP-W420+ also can connect to each other up to 7,000 meters with built-in panel antenna.

## Dimension

### IAP-W420+

Dimension (Unit =mm)

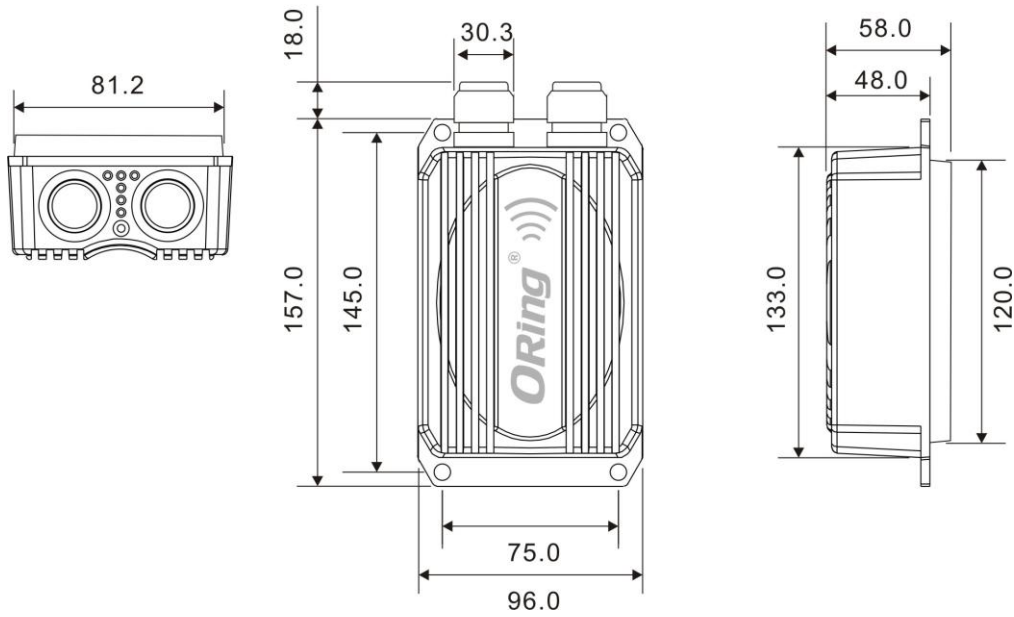

### IAP-W422+

Dimension (Unit =mm)

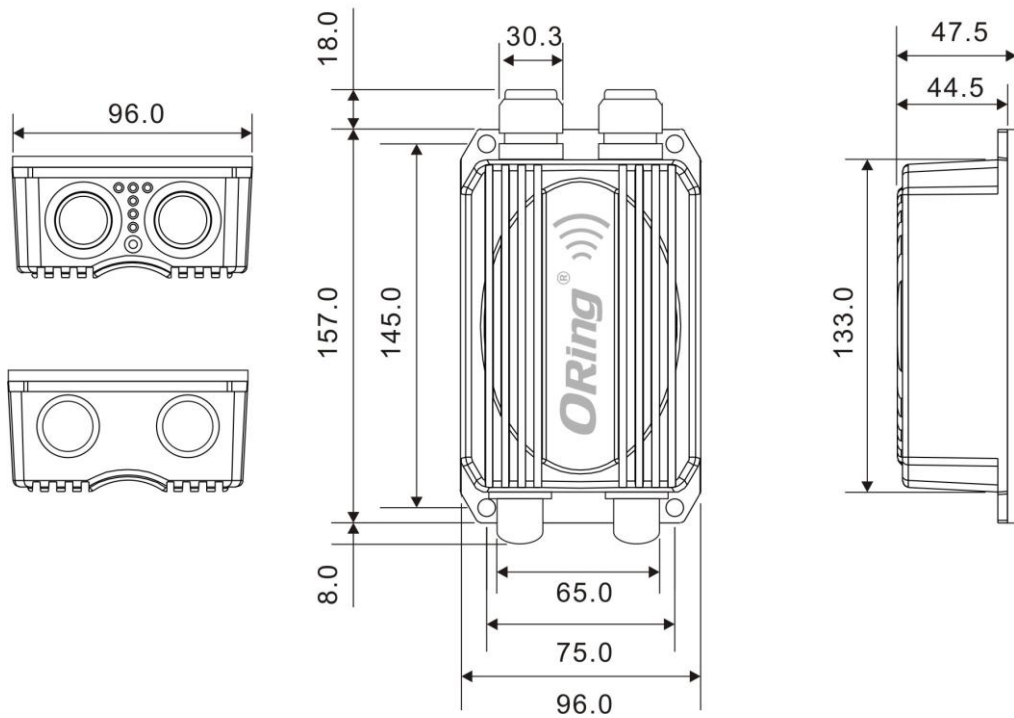

## Specifications

ORing WLAN Access Point Model	IAP-W420+	IAP-W422+
<b>Physical Ports</b>		
10/100 Base-T(X) Ports in RJ45 Auto MDI/MDIX	<b>2(one port with PoE)</b>	
<b>WLAN interface</b>		
Operating Mode	AP/Bridge/AP-Client/Client	
Antenna Connector	Build-in 10dBi panel antenna	2 x External N-type antenna connector
Radio Frequency Type	OFDM	
Modulation	IEEE802.11b: CCK, DQPSK, DBPSK IEEE802.11g/n: OFDM with BPSK, QPSK, 16QAM, 64QAM	
Frequency Band	America / FCC : 2.412~2.462 GHz (11 channels ) Europe CE / ETSI: 2.412~2.472 GHz ( 13 channels )	
Transmission Rate	IEEE802.11b: 11, 5.5, 2, 1 Mbps; IEEE 802.11g: 54, 48, 36, 24, 18, 12, 9, 6 Mbps IEEE 802.11n: up to 300Mbps	
Transmit Power	800mw Max.	
Receiver Sensitivity	-96dBi ± 2dBi	
Encryption Security	WEP: (64-bit ,128-bit key supported) WPA/WPA2 :802.11i(WEP and AES encryption) WPAPSK (256-bit key pre-shared key supported) 802.1X Authentication supported TKIP encryption	
Wireless Security	SSID broadcast disable	
<b>Protocol Support</b>		
Protocol	ARP,BOOTP, DHCP, DNS, HTTPs, IP, ICMP, SNTP, TCP, UDP, RADIUS, SNMP, STP (IEEE 802.1D)	
<b>LED indicators</b>		
Power indicator	1 x LED, Green On: Power(PoE) is on and functioning Normally.	
10/100Base-T(X) RJ45 port indicator	2 x LED, Green On: Port Link / Act, Blinking: data transmission	
WLAN LED	3 x LED, Green for WLAN Strength: 1<30%, 2<60%, 3<90%	
<b>Power</b>		
Input power	48VDC from P.o.E	
Power consumption (Typ.)	9watts	
<b>Physical Characteristic</b>		
Enclosure	IP-67	
Dimension (W x D x H)	157(W)x 96(D)x 58(H) mm (6.18x 3.77x 2.28 inch.)	157(W)x 96(D)x 47.5(H) mm (6.18x 3.77x 1.87 inch.)
Weight (g)	720 g	790 g
<b>Environmental</b>		
Storage Temperature	-30 to 85°C (-22 to 185°F)	
Operating Temperature	-20 to 70°C (-4 to 158°F)	
Operating Humidity	100% Non-condensing	
<b>Regulatory approvals</b>		
EMI	FCC Part 15, CISPR (EN55022) class A	
EMS	EN61000-4-2 (ESD), EN61000-4-3 (RS), EN61000-4-4 (EFT), EN61000-4-5 (Surge), EN61000-4-6 (CS), EN61000-4-8, EN61000-4-11	
Shock	IEC60068-2-27	
Free Fall	IEC60068-2-32	
Vibration	IEC60068-2-6	

Safety	EN60950-1
Warranty	3 years

## Ordering Information

IAP-W **A** **B** **C** +

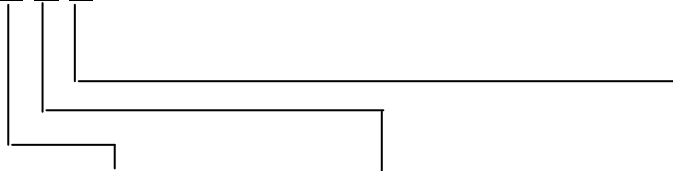

Code Definition	Wireless Mode	10/100Base-T(X) Port Number	Antenna Connector Number
Option	- 1: 802.11 b/g - 2: 802.11 a - 3: 802.11 a/b/g - 4: 802.11 b/g/n - 5: 802.11 a/n - 6: 802.11 a/b/g/n	-"2": 2 port	-"2": 2 connectors

	Model Name	Description
Available Model	IAP-W420+_US	Industrial outdoor IEEE 802.11 b/g/n wireless access point with 2x10/100Base-T(X), IP-67 grade, US band
	IAP-W420+_EU	Industrial outdoor IEEE 802.11 b/g/n wireless access point with 2x10/100Base-T(X), IP-67 grade, EU band
	IAP-W422+_US	Industrial outdoor IEEE 802.11 b/g/n wireless access point with 2x10/100Base-T(X), IP-67 grade, N-type antenna connector, US band
	IAP-W422+_EU	Industrial outdoor IEEE 802.11 b/g/n wireless access point with 2x10/100Base-T(X), IP-67 grade, N-type antenna connector, EU band

## Packing List

- IAP- W420+ / W422+ x 1
- Pole Mount Kit x 1
- CD x 1
- RJ-45 Rubber Seal x 2
- Quick Installation Guide x 1
- N-type ANT. Rubber Seal x 2 (IAP-W422+)



Компания «ЭлектроПласт» предлагает заключение долгосрочных отношений при поставках импортных электронных компонентов на взаимовыгодных условиях!

Наши преимущества:

- Оперативные поставки широкого спектра электронных компонентов отечественного и импортного производства напрямую от производителей и с крупнейших мировых складов;
- Поставка более 17-ти миллионов наименований электронных компонентов;
- Поставка сложных, дефицитных, либо снятых с производства позиций;
- Оперативные сроки поставки под заказ (от 5 рабочих дней);
- Экспресс доставка в любую точку России;
- Техническая поддержка проекта, помощь в подборе аналогов, поставка прототипов;
- Система менеджмента качества сертифицирована по Международному стандарту ISO 9001;
- Лицензия ФСБ на осуществление работ с использованием сведений, составляющих государственную тайну;
- Поставка специализированных компонентов (Xilinx, Altera, Analog Devices, Intersil, Interpoint, Microsemi, Aeroflex, Peregrine, Syfer, Eurofarad, Texas Instrument, Miteq, Cobham, E2V, MA-COM, Hittite, Mini-Circuits, General Dynamics и др.);

Помимо этого, одним из направлений компании «ЭлектроПласт» является направление «Источники питания». Мы предлагаем Вам помощь Конструкторского отдела:

- Подбор оптимального решения, техническое обоснование при выборе компонента;
- Подбор аналогов;
- Консультации по применению компонента;
- Поставка образцов и прототипов;
- Техническая поддержка проекта;
- Защита от снятия компонента с производства.



#### Как с нами связаться

**Телефон:** 8 (812) 309 58 32 (многоканальный)

**Факс:** 8 (812) 320-02-42

**Электронная почта:** [org@eplast1.ru](mailto:org@eplast1.ru)

**Адрес:** 198099, г. Санкт-Петербург, ул. Калинина, дом 2, корпус 4, литера А.