



# Grove – MOSFET User Manual

Release date: 2015/9/22

Version: 1.0

Wiki: [http://www.seeedstudio.com/wiki/Grove - MOSFET](http://www.seeedstudio.com/wiki/Grove_-_MOSFET)

Bazaar: <http://www.seeedstudio.com/depot/Grove-MOSFET-p-1594.html>

## Document Revision History

---

Revision	Date	Author	Description
1.0	Sep 22, 2015	Jiankai.li	Create file

## Contents

Document Revision History .....	2
1. Introduction .....	2
2. Specification .....	3
3. Interface .....	4
4. Demonstration .....	5
4.1 With Arduino .....	5
4.2 With Raspberry Pi .....	6
5. Resource .....	8

### *Disclaimer*

*For physical injuries and possessions loss caused by those reasons which are not related to product quality, such as operating without following manual guide, natural disasters or force majeure, we take no responsibility for that.*

*Under the supervision of Seeed Technology Inc., this manual has been compiled and published which covered the latest product description and specification. The content of this manual is subject to change without notice.*

### *Copyright*

*The design of this product (including software) and its accessories is under tutelage of laws. Any action to violate relevant right of our product will be penalized through law. Please consciously observe relevant local laws in the use of this product.*

## 1. Introduction

---

Grove - MOSFET enables you to control higher voltage project, say 15VDC, with low voltage, say 5V, on microcontroller. MOSFET is also a kind of switch, but its switching frequency can reach up to 5MHz, much faster than normal mechanical relay. There are two screw terminals on the board. One for outer power source and the other for device you want to control. Grove - MOSFET will pass the power from one end to another when closed. But if outer power source is absent, your device can still draw power from microcontroller via the Grove interface.

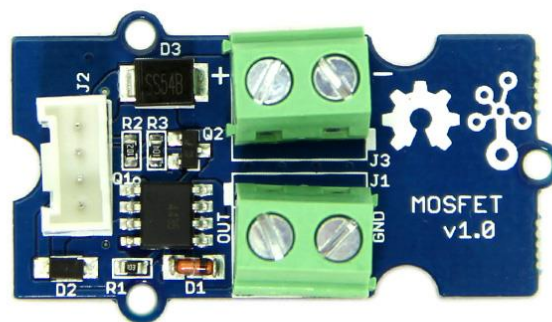

## 2. Specification

---

- Working voltage: 5V
- Vin: 5 ~ 15V
- MOSFET Model: CJQ4435

### 3. Interface

---

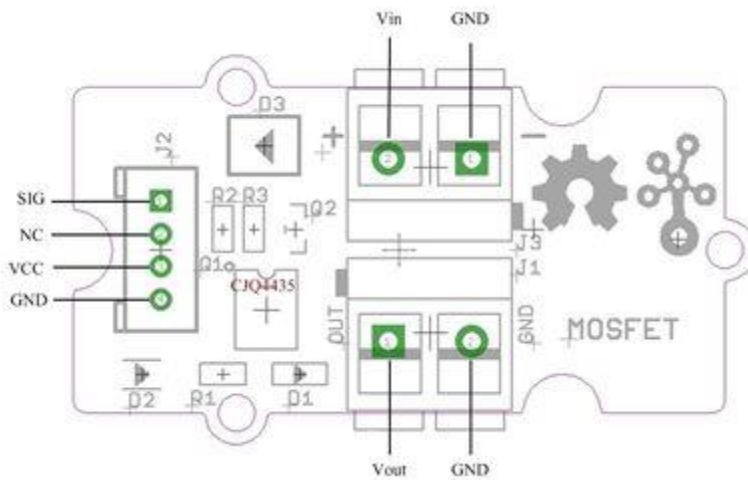

- Vin: accepts 5V ~ 15V power of which current is less than 2A.
- Vout: attach actuators here.

## 4. Demonstration

---

### 4.1 With Arduino

Here we demonstrates how to use Grove - MOSFET to control a motor. We provide power for it with external power source, but if your controlled device needs current smaller than 300mA, Seeeduino can totally support it and no extra power source needed.

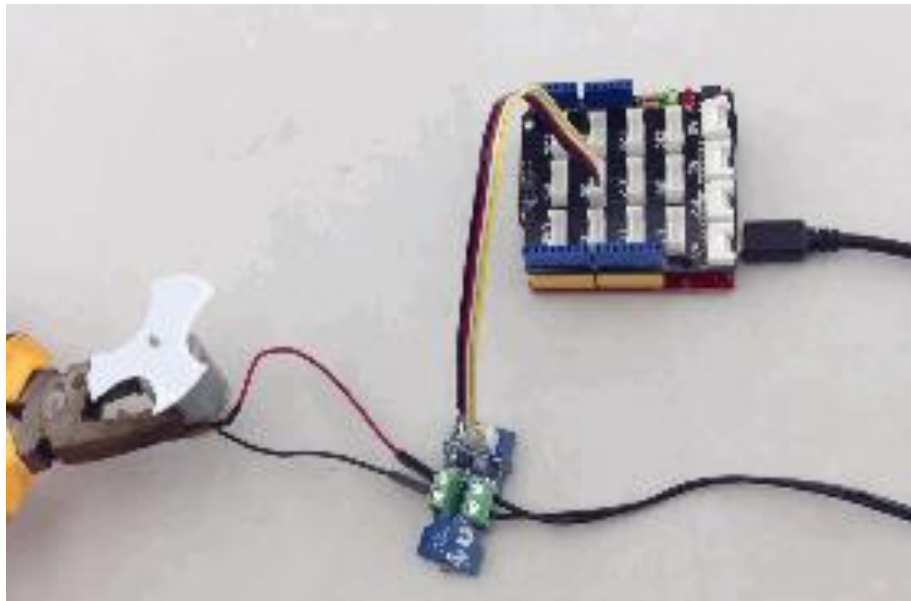

```
// demo of Grove - MOSFET
// use pin 6 to control a motor

int motorPin = 6;

void setup()
{
  Serial.begin(38400);
  pinMode(motorPin, OUTPUT);
  Serial.println("Grove - MOSFET Test Demo!");
}

void loop()
{
  motorOnThenOffWithSpeed();
  motorAcceleration();
}

void motorOnThenOffWithSpeed()
{
```



```

int onSpeed = 200; // a number between 0 (stopped) and 255 (full speed)
int onTime = 2500;
int offSpeed = 50; // a number between 0 (stopped) and 255 (full speed)
int offTime = 1000;
analogWrite(motorPin, onSpeed);
delay(onTime);
analogWrite(motorPin, offSpeed);
delay(offTime);
}

void motorAcceleration()
{
  int delayTime = 50;
  for(int i=0; i<256; i++)
  {
    analogWrite(motorPin, i);
    delay(delayTime);
  }

  for(int i=255; i>=0; i--)
  {
    analogWrite(motorPin, i);
    delay(delayTime);
  }
}

```

## 4.2 With Raspberry Pi

1. You should have got a raspberry pi and a grovepi or grovepi+.
2. You should have completed configuring the development enviroment, otherwise follow [here](#).
3. Connection.

- Plug the sensor to grovepi socket D6 by using a grove cable.

4. Navigate to the demos' directory:

```
cd yourpath/GrovePi/Software/Python/
```

- To see the code

```
nano grove_mosfet.py # "Ctrl+x" to exit #
import time
import grovepi
```

```
# Connect the Grove MOSFET to analog port D6
# SIG, NC, VCC, GND
mosfet = 6

grovepi.pinMode(mosfet, "OUTPUT")
time.sleep(1)

while True:
    try:
        # Full speed
        grovepi.analogWrite(mosfet, 255)
        print "full speed"
        time.sleep(2)

        # Half speed
        grovepi.analogWrite(mosfet, 128)
        print "half speed"
        time.sleep(2)

        # Off
        grovepi.analogWrite(mosfet, 0)
        print "off"
        time.sleep(2)

    except KeyboardInterrupt:
        grovepi.analogWrite(mosfet, 0)
        break
    except IOError:
        print "Error"
```

## 5. Run the demo.

```
sudo python grove_mosfet.py
```

## 5. Resource

---

- [Grove - MOSFET Eagle File](#)
- [CJQ4435 Datasheet](#)
- [MOSFET\\_WIKI](#)
- [Getting started with Arduino](#)



Компания «ЭлектроПласт» предлагает заключение долгосрочных отношений при поставках импортных электронных компонентов на взаимовыгодных условиях!

Наши преимущества:

- Оперативные поставки широкого спектра электронных компонентов отечественного и импортного производства напрямую от производителей и с крупнейших мировых складов;
- Поставка более 17-ти миллионов наименований электронных компонентов;
- Поставка сложных, дефицитных, либо снятых с производства позиций;
- Оперативные сроки поставки под заказ (от 5 рабочих дней);
- Экспресс доставка в любую точку России;
- Техническая поддержка проекта, помощь в подборе аналогов, поставка прототипов;
- Система менеджмента качества сертифицирована по Международному стандарту ISO 9001;
- Лицензия ФСБ на осуществление работ с использованием сведений, составляющих государственную тайну;
- Поставка специализированных компонентов (Xilinx, Altera, Analog Devices, Intersil, Interpoint, Microsemi, Aeroflex, Peregrine, Syfer, Eurofarad, Texas Instrument, Miteq, Cobham, E2V, MA-COM, Hittite, Mini-Circuits, General Dynamics и др.);

Помимо этого, одним из направлений компании «ЭлектроПласт» является направление «Источники питания». Мы предлагаем Вам помощь Конструкторского отдела:

- Подбор оптимального решения, техническое обоснование при выборе компонента;
- Подбор аналогов;
- Консультации по применению компонента;
- Поставка образцов и прототипов;
- Техническая поддержка проекта;
- Защита от снятия компонента с производства.



#### Как с нами связаться

**Телефон:** 8 (812) 309 58 32 (многоканальный)

**Факс:** 8 (812) 320-02-42

**Электронная почта:** [org@eplast1.ru](mailto:org@eplast1.ru)

**Адрес:** 198099, г. Санкт-Петербург, ул. Калинина, дом 2, корпус 4, литера А.