

NEW

0.5mm Pitch, Vertical Connection Board-to-Micro Coaxial Cable Connectors

DF80 Series

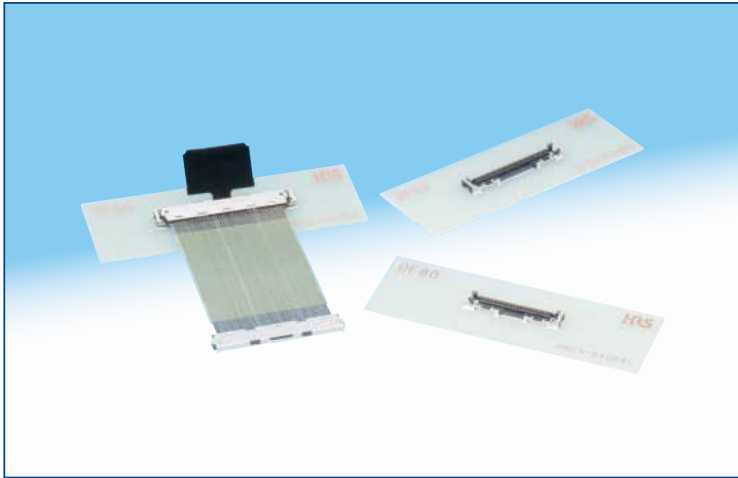

Excellent mating workability

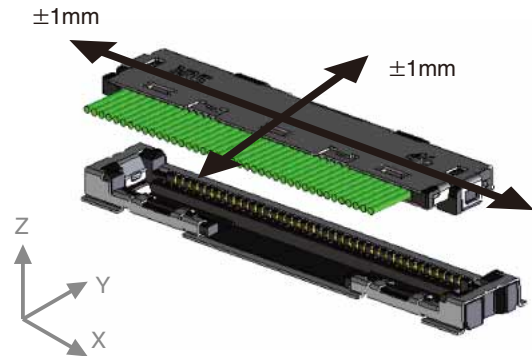

Figure 1

■ Features

1.High speed signal connector

With its excellent signal characteristics, this series conforms to ver 1.2 of eDP™ [Embedded DisplayPort™] with 2.7 Gbps and 5.4 Gbps signal transmission speed.

2.Space saving and low mated height

Designed to be a space saving connector, it features a 0.5mm pitch, low mated height, single row contact arrangement and vertical connection type.

3.Excellent mating workability

The mating position can be easily identified visually and has a long insertion guide for mating. The length of the guide is $\pm 1\text{mm}$ (Fig. 1)

4.Highly reliable contact structure

The DF80 series utilizes its effective contact length of 0.5mm and its pinching type 2 point contacting structure, to ensure high contact reliability. (Fig. 2)

5.Effective Shielding Enhanced

Utilizing multiple contact areas between the plug shell and the receptacle shell provides stability and contact reliability. (Fig. 3)

6.Durable plug structure

The metal shell is comprised of two sheets to cover up the plug and form a rigid structure.

7.Secure lock structure with a tactile click

A tactile click ensures that the lock function has been completed and the actuator is secured. This structure also delivers excellent lock retention.

8.Adaptable Structure

The structure was designed to allow a pull tab to be utilized to aid in the removal of the connectors.

9.Halogen free and RoHS Compliant

Chlorine and Bromine are not used in amounts that exceed the standard values in these connectors.

*Defined according to IEC 61249-2-21

Br: 900ppm or less, Cl: 900ppm or less and (Br + Cl): 1,500ppm or less

High contact reliability

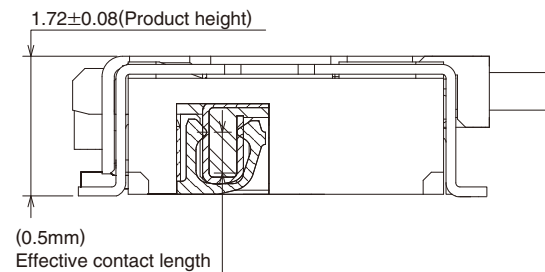
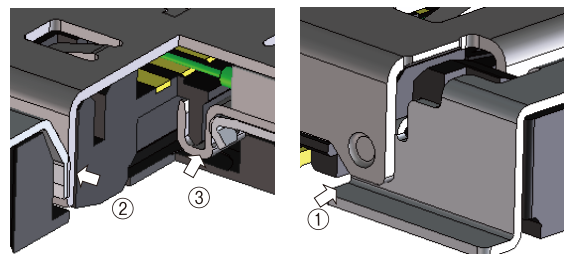
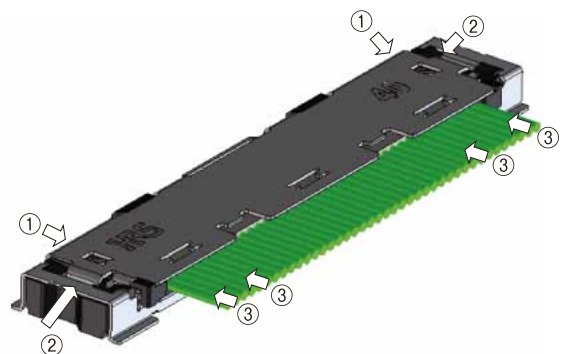

Figure 2

Enhancement of shielding effectiveness



Many ground springs are used (8 locations)

Figure 3

Product specification

Ratings	Current rating	[Discreet cable] AWG32 : 0.5A AWG36 : 0.35A [Micro coaxial cable] AWG40 : 0.2A AWG42 : 0.2A AWG44 : 0.15A AWG46 : 0.1A	(Note 3)	Operating temperature range Operating humidity range	-35 - 85°C (Note 1) 20 - 80%
	Voltage rating	AC/DC 50V		Storage temperature range Storage humidity range	-10 - 60°C (Note 2) 40 - 70% (Note 2)

Items	Specifications	Condition
1. Insulation resistance	50MΩ min.	Measured at DC 100V
2. Withstanding voltage	No flashover and insulation breakdown	AC 150V for one minute
3. Contact resistance	Signal: 80mΩ max. GND: 80mΩ max.	Measured at 100mA (DC or 1000Hz)
4. Vibration resistance	No electrical discontinuity of 1 μs or more	Frequency: 10 to 55Hz, single amplitude of 0.75mm, 3 directions, 10 cycles for each direction
5. Humidity resistance	Contact resistance (amount of variation from the start): 50mΩ max. Insulation resistance: 25MΩ min.	Exposed for 96 hours at the temperature of 40±2°C and the humidity of 90 to 95%
6. Temperature cycle	Contact resistance (amount of variation from the start): 50mΩ max. Insulation resistance: 25MΩ min.	(-55°C: 30 minutes → 5 to 35°C: 2 to 3 minutes → 85°C: 30 minutes → 5 to 35°C: 2 to 3 minutes) 5 cycles
7. Number of mating and un-mating cycles	Contact resistance (amount of variation from the start): 50mΩ max.	30 mating and un-mating cycles
8. Resistance to soldering heat	No melting of resin part that affects to performance	Reflow: At the recommended temperature profile Manual soldering: The temperature of the soldering iron of 350°C for 3 seconds

(Note 1) This shall include the temperature rise caused by current flow.

(Note 2) The term "storage" refers to products stored for long period of time prior to mounting on the board and use. The operating temperature and humidity range covers the non-conducting conditions of connectors after being mounted on the board and the temporary storage conditions during transportation.

(Note 3) Current rating shall be set according to the value of the temperature rise of only connector part.

(Note 4) The specification shown above represents general requirements for this series. Please refer to "Delivery Specification" for a specific official agreement.

Material

Product	Part	Material	Finish	Specification
Receptacle	Insulator	LCP (Liquid Crystalline Polymer)	Black color	UL94V-0
	Contacts	Phosphor bronze	Gold plated	————
	Metal fitting	Phosphor bronze	Tin plated	————
Plug	Insulator	LCP	Black color	UL94V-0
	Contacts	Phosphor bronze	Gold plated	————
	Outer metal shell	Stainless steel	Tin plated	————
Shell	Outer metal shell	Stainless steel	Tin plated	————

Ordering information

Please use the information below when identifying the specification of the product based on the numbering.

Please select a product based on the ordering information described on page 4 to 8 of this catalog when ordering.

Connector

DF **80** - ***** **S** - **0.5** **V** (******)
 ① ② ③ ④ ⑤ ⑥ ⑦
DF **80** - ***** **P** - **SHL**
 ① ② ③ ④ ⑧

①	Series name: DF
②	Series number: 80
③	Number of contacts: 30, 40 and 50
④	Connector type S: Receptacle P: Plug
⑤	Contact pitch: 0.5mm
⑥	Termination type V: Straight SMT SD: Micro coaxial cable plug
⑦	Packaging type (51): Embossed tape packaging product
⑧	Attached parts SHL: Outer metal shell

■ Receptacle (SMT)

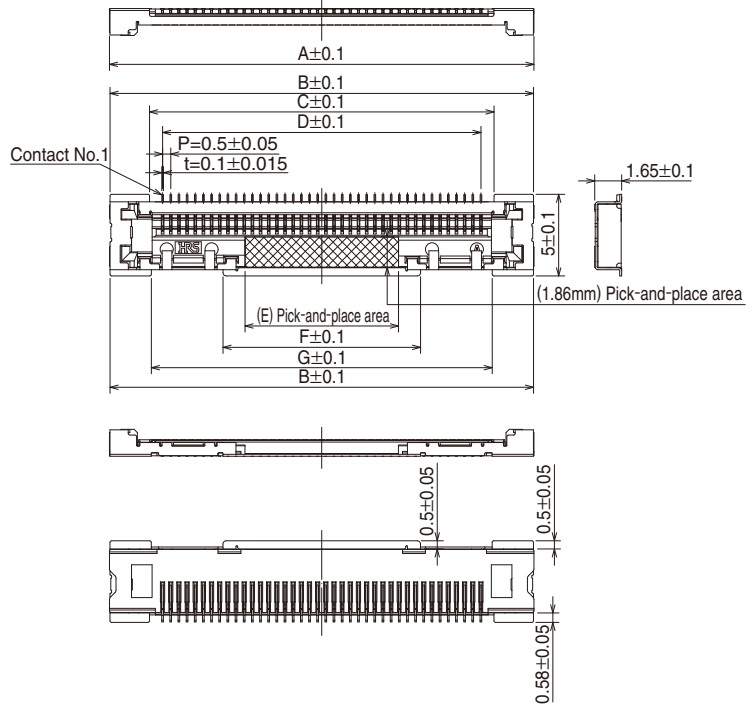

[Specification number] -**, (**)
(51): Embossed tape packaging

Unit: mm

Part number	HRS No.	Number of contacts	A	B	C	D	E	F	G
DF80-30S-0.5V(**)	CL662-8004-0-**	30	21.00	20.94	16.10	14.50	4.40	7.10	15.88
DF80-40S-0.5V(**)	CL662-8001-2-**	40	26.00	25.94	21.10	19.50	9.40	12.10	20.88
DF80-50S-0.5V(**)	CL662-8007-9-**	50	31.00	30.94	26.10	24.50	14.40	17.10	25.88

(Note 1) Please order by number of reels for embossed tape packaging products. (5,000 pieces per reel)

◆ Recommended Pattern Drawing

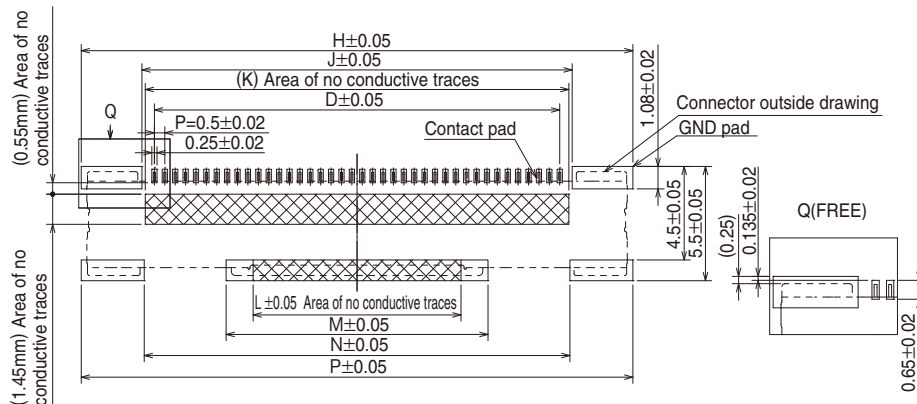

Unit: mm

Part number	HRS No.	Number of contacts	H	J	K	D	L	M	N	P
DF80-30S-0.5V(**)	CL662-8004-0-**	30	21.54	15.70	15.38	14.50	5.00	7.60	15.48	21.54
DF80-40S-0.5V(**)	CL662-8001-2-**	40	26.54	20.70	20.38	19.50	10.00	12.60	20.48	26.54
DF80-50S-0.5V(**)	CL662-8007-9-**	50	31.54	25.70	25.38	24.50	15.00	17.60	25.48	31.54

■ Plug

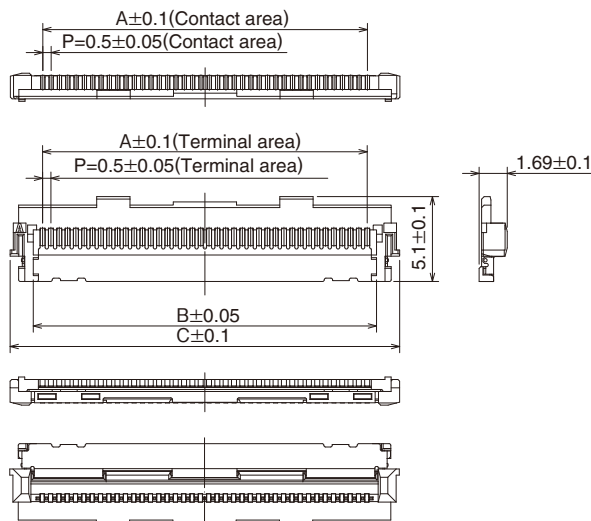

[Specification number] -**, (**)
(51): Embossed tape packaging

Unit: mm

Part number	HRS No.	Number of contacts	A	B	C	D
DF80-30P-0.5SD(**)	CL662-8005-3-**	30	14.50	15.62	18.40	15.48
DF80-40P-0.5SD(**)	CL662-8002-5-**	40	19.50	20.62	23.40	20.48
DF80-50P-0.5SD(**)	CL662-8008-1-**	50	24.50	25.62	28.40	25.48

(Note 1) Please order by number of reels for embossed tape packaging products. (5,000 pieces per reel)

(Note 2) The outer metal shell (DF80-*P-SHL) is required for fine coaxial cable termination.

◆ Recommended fine coaxial cable preparation

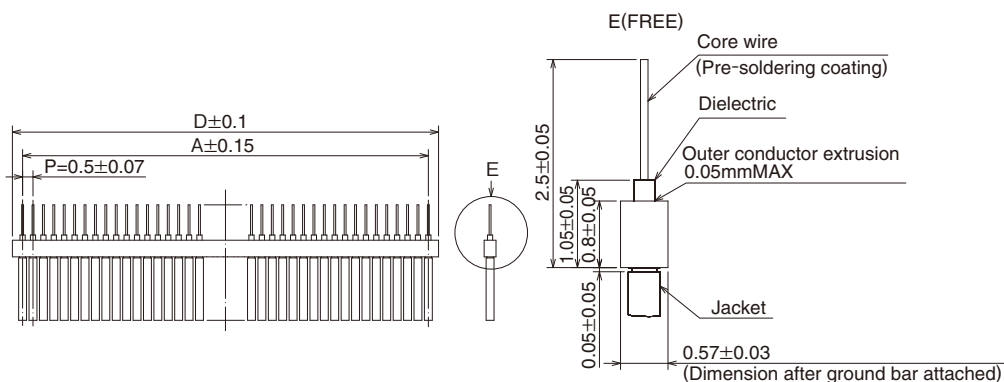

(Note 1) Core conductor requires pre-soldering (lead free) treatment.

Outer metal shell

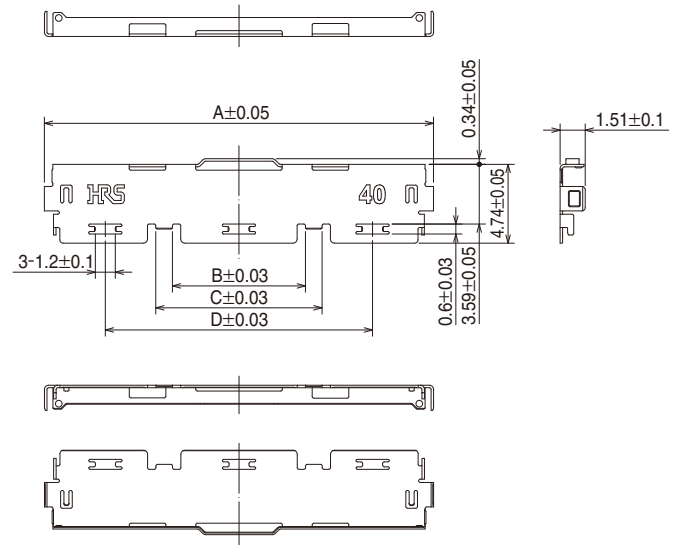
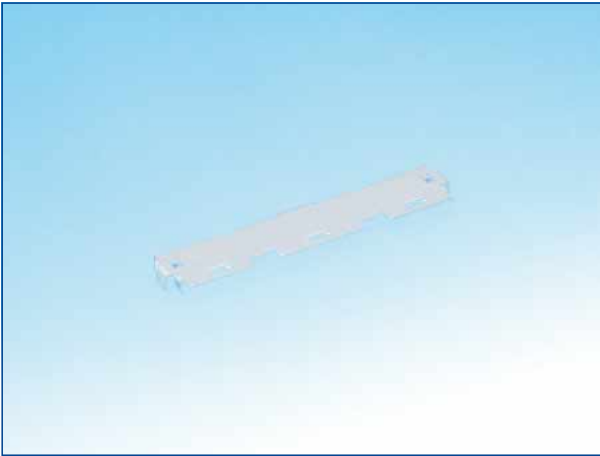

Unit: mm

Part number	HRS No.	Number of contacts	A	B	C	D
DF80-30P-SHL	CL662-8006-6	30	18.40	4.50	6.50	11.07
DF80-40P-SHL	CL662-8003-8	40	23.40	8.00	10.00	16.07
DF80-50P-SHL	CL662-8009-4	50	28.40	10.00	12.00	21.07

(Note 1) Amount of sale is by number of reels. Please order by number of reels. (10,000 pieces per reel)

Precautions for use

1. Recommended temperature profile (Applicable to temperature profile for lead free mounting)	<p>Applicable conditions</p> <ol style="list-style-type: none"> 1. Peak temperature : 250°C max. 2. Heating : 220°C min. for 60 seconds max. 3. Pre-heating : 150 to 180°C for 90 to 120 seconds 4. Number of cycles : Up to 2 cycles <p>* Solder composition : Sn-3Ag-0.5Cu</p> <p>(Note 1) Values in this temperature profile are one of the recommendations.</p>
2. Recommended manual soldering conditions	Temperature of the soldering iron: 350°C max. Soldering time: 3 seconds max.
3. Recommended screen thickness and open area ration (Pattern area ratio)	Thickness: 0.1mm Open area ratio: Lead terminal: 100% Ground terminal: 100%
4. Board distortion	Maximum of 0.02mm at the center of the connector with both ends of the connector as reference points
5. Cleaning conditions	IPA (Isopropyl Alcohol) cleaning is permitted. (Cleaning is not recommended as it may change the feel of the mating and un-mating of the connector. Please contact your Hirose sales representative for information if you plan to use any other cleaning agents.)

◆ Embossed carrier tape dimensional drawing (In accordance with JIS C 0806)

● Receptacle

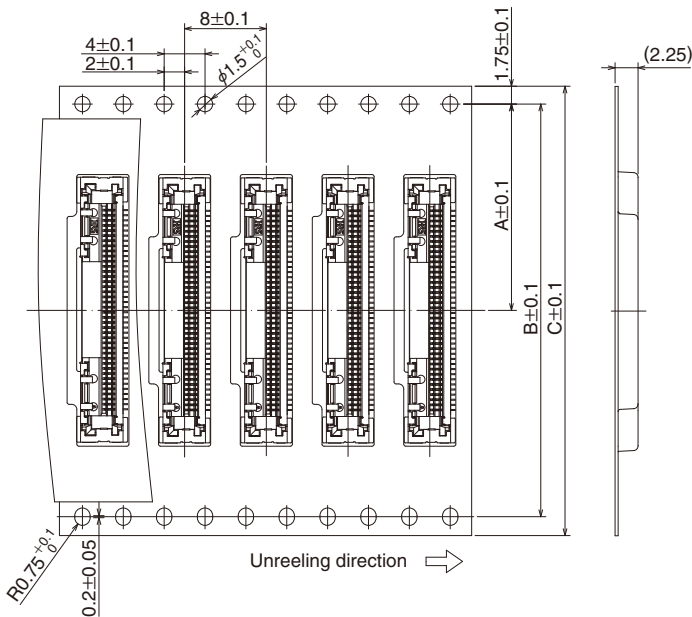

● Reel status dimensional drawing

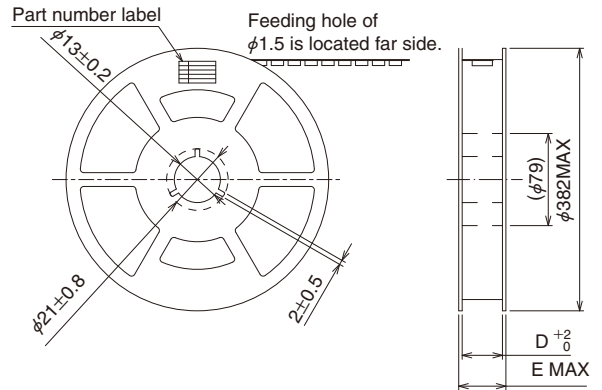

Unit: mm

Part number	HRS No.	Number of contacts	A	B	C	D	E
DF80-30S-0.5V(51)	CL662-8004-0-51	30	20.2	40.4	44.0	44.4	50.4
DF80-40S-0.5V(51)	CL662-8001-2-51	40	20.2	40.4	44.0	44.4	50.4
DF80-50S-0.5V(51)	CL662-8007-9-51	50	20.2	40.4	44.0	44.4	50.4

◆ Embossed carrier tape dimensional drawing

● Plug

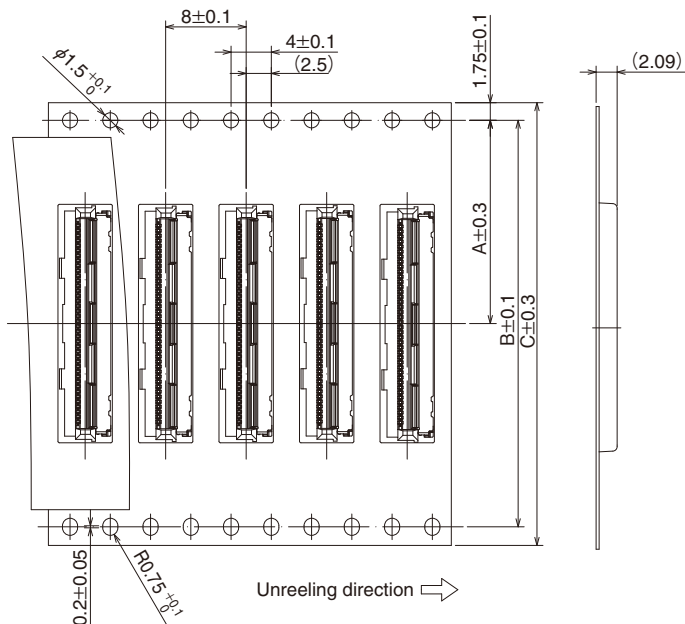

● Reel status dimensional drawing

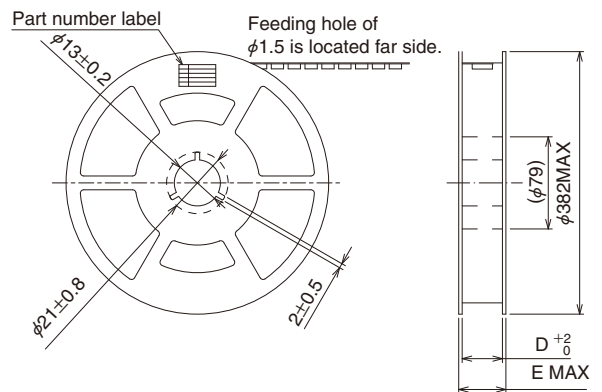

Unit: mm

Part number	HRS No.	Number of contacts	A	B	C	D	E
DF80-30P-0.5SD(51)	CL662-8005-3-51	30	20.2	40.4	44.0	44.4	50.4
DF80-40P-0.5SD(51)	CL662-8002-5-51	40	20.2	40.4	44.0	44.4	50.4
DF80-50P-0.5SD(51)	CL662-8008-1-51	50	20.2	40.4	44.0	44.4	50.4

◆ Precautions for use

Alert notes

■ Mating insertion operation

- When inserting the plug, press straight down on the entire surface of the plug into place.
- Please note that inserting the plug while holding the terminal cable may cause an inclined insertion and may result in breakage of the connector.

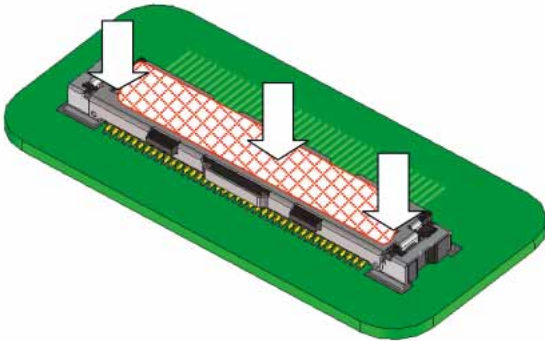

■ Removal operation

- There are two ways to remove the plug. [Removing it with your fingers or pulling it out with a pull tab]
- Do NOT pull-out the plug while holding the terminal cable. It may cause a disconnection of the cable and breakage of the connector.

[Removing with fingers]

To un-mate the plug with your fingers, lift up the hooking part that is installed on the metal shell of the plug connector.

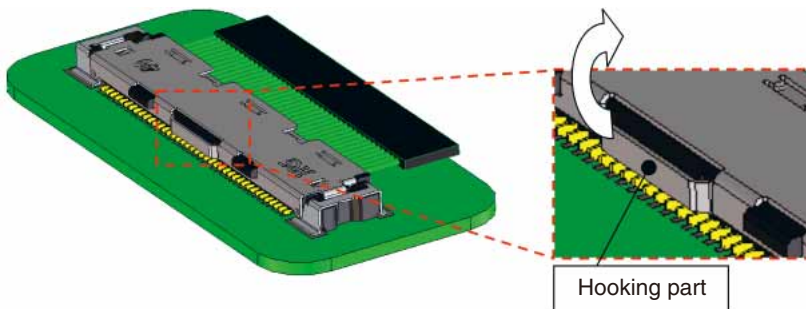

- Please be careful when trying to manipulate the hooking part as it is made of metal and it may hurt your finger or damage your finger nail.

[Removal via the pull tab]

Un-mate the plug by pulling-out the pull tab, installed on the plug connector, toward the direction of arrow (in a vertical direction).

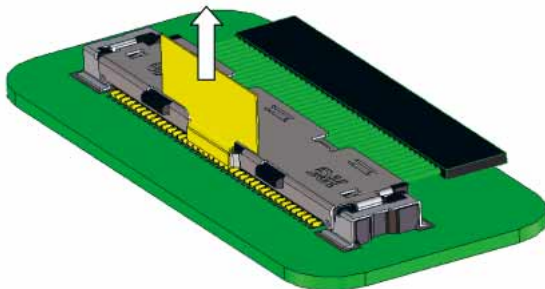

- Do NOT insert or pull-out the plug while the connector is not mounted to a board. It may cause breakage of the connector or deformation of the terminal.
- Do NOT insert or pull-out the plug with excessive force. It may cause breakage of the connector.
- Do NOT apply the flux in the manual soldering process. It may cause a flux blister on the connector.

USA:

HIROSE ELECTRIC (U.S.A.), INC. Headquarters

2688 Westhills Court, Simi Valley, CA 93065-6235
Phone : +1-805-522-7958
Fax : +1-805-522-3217
<http://www.hiroseusa.com>

USA:

HIROSE ELECTRIC (U.S.A.), INC. San Jose Office

20400 Stevens Creek Blvd., Ste 250, Cupertino,
CA 95014
Phone : +1-408-253-9640
Fax : +1-408-253-9641
<http://www.hiroseusa.com>

USA:

HIROSE ELECTRIC (U.S.A.), INC. Detroit Office (Automotive)

37677 Professional Center Drive, Suite #100C
Livonia, MI 48154
Phone : +1-734-542-9963
Fax : +1-734-542-9964
<http://www.hiroseusa.com>

THE NETHERLANDS:

HIROSE ELECTRIC EUROPE B.V.

Hogehillweg #8 1101 CC Amsterdam Z-0
Phone : +31-20-6557460
Fax : +31-20-6557469
<http://www.hiroseeurope.com>

GERMANY:

HIROSE ELECTRIC EUROPE B.V. GERMAN BRANCH

Herzog-Carl-Strasse 4 D-73760 Ostfildern
(Scharnhauser Park)
Phone : +49-711-4560-02-1
Fax : +49-711-4560-02-299
<http://www.hirose.de>

UNITED KINGDOM:

HIROSE ELECTRIC EUROPE B.V. UK BRANCH

First Floor, St Andrews House, Caldecotte Lake
Business Park, Milton Keynes MK7 8LE
Phone : +44-1908-369060
Fax : +44-1908-369078
<http://www.hirose.co.uk>

CHINA:

HIROSE ELECTRIC (SHANGHAI) CO., LTD.

1601, Henderson Metropolitan, NO.300, East Nanjing
Road, Huangpu District, Shanghai, China 200001
Phone : +86-21-6391-3355
Fax : +86-21-6391-3335
<http://www.hirose-china.com.cn>

CHINA:

HIROSE ELECTRIC (SHANGHAI) CO., LTD. BEIJING BRANCH

A1001, Ocean International Center, Building 56# East 4th
Ring Middle Road, Chao Yang District, Beijing, 100025
Phone : +86-10-5165-9332
Fax : +86-10-5908-1381
<http://www.hirose-china.com.cn>

CHINA:

HIROSE ELECTRIC TECHNOLOGIES (SHENZHEN) CO., LTD.

Room 09-13, 19/F, Office Tower Shun Hing Square, Di Wang Commercial Centre
5002, ShenNanDong Road, ShenZhen City, Guangdong Province, 518008
Phone : +86-755-8207-0851
Fax : +86-755-8207-0873
<http://www.hirose-china.com.cn>

HONG KONG:

HIROSE ELECTRIC HONGKONG TRADING CO., LTD.

Room 1001, West Wing, Tsim Sha Tsui Centre, 66
Mody Road, Tsim Sha Tsui East, Kowloon, Hong Kong
Phone : +852-2803-5338
Fax : +852-2591-6560
<http://www.hirose-hongkong.com.hk>

TAIWAN:

HIROSE ELECTRIC TAIWAN CO., LTD.

103 8F, No.87, Zhengzhou Rd., Taipei
Phone : +886-2-2555-7377
Fax : +886-2-2555-7350
<http://www.hirose-taiwan.com.tw>

KOREA:

HIROSE KOREA CO., LTD.

1261-10, Jeoungwhang-Dong, Shihung-City,
Kyunggi-Do 429-450
Phone : +82-31-496-7000, 7124
Fax : +82-31-496-7100
<http://www.hirose.co.kr>

SINGAPORE:

HIROSE ELECTRIC SINGAPORE PTE. LTD.

10 Anson Road #26-16 International Plaza 079903
Phone : +65-6324-6113
Fax : +65-6324-6123
<http://www.hirose-singapore.com.sg>

INDIA:

HIROSE ELECTRIC SINGAPORE PTE. LTD. BANGALORE LIAISON OFFICE

Unit No.03, Ground Floor, Explorer Building International Tech
Park Whitefield Road, Bangalore 560066 Karnataka, India
Phone : +65-6324-6113
Fax : +65-6324-6123
<http://www.hirose-singapore.com.sg>



HRS

HIROSE ELECTRIC CO.,LTD.

6-3, Nakagawa Chuoh-2-Chome, Tsuzuki-Ku, Yokohama-Shi 224-8540, JAPAN
TEL: +81-45-620-3526 Fax: +81-45-591-3726
<http://www.hirose.com>
<http://www.hirose-connectors.com>



Компания «ЭлектроПласт» предлагает заключение долгосрочных отношений при поставках импортных электронных компонентов на взаимовыгодных условиях!

Наши преимущества:

- Оперативные поставки широкого спектра электронных компонентов отечественного и импортного производства напрямую от производителей и с крупнейших мировых складов;
- Поставка более 17-ти миллионов наименований электронных компонентов;
- Поставка сложных, дефицитных, либо снятых с производства позиций;
- Оперативные сроки поставки под заказ (от 5 рабочих дней);
- Экспресс доставка в любую точку России;
- Техническая поддержка проекта, помощь в подборе аналогов, поставка прототипов;
- Система менеджмента качества сертифицирована по Международному стандарту ISO 9001;
- Лицензия ФСБ на осуществление работ с использованием сведений, составляющих государственную тайну;
- Поставка специализированных компонентов (Xilinx, Altera, Analog Devices, Intersil, Interpoint, Microsemi, Aeroflex, Peregrine, Syfer, Eurofarad, Texas Instrument, Miteq, Cobham, E2V, MA-COM, Hittite, Mini-Circuits, General Dynamics и др.);

Помимо этого, одним из направлений компании «ЭлектроПласт» является направление «Источники питания». Мы предлагаем Вам помощь Конструкторского отдела:

- Подбор оптимального решения, техническое обоснование при выборе компонента;
- Подбор аналогов;
- Консультации по применению компонента;
- Поставка образцов и прототипов;
- Техническая поддержка проекта;
- Защита от снятия компонента с производства.



Как с нами связаться

Телефон: 8 (812) 309 58 32 (многоканальный)

Факс: 8 (812) 320-02-42

Электронная почта: org@eplast1.ru

Адрес: 198099, г. Санкт-Петербург, ул. Калинина, дом 2, корпус 4, литера А.