

PmodDA1™ Reference Manual

Revised May 24, 2016

This manual applies to the PmodDA1 rev. C

Overview

The Digilent PmodDA1 is an 8-bit Digital-to-Analog Converter module that can output up to four different analog signals simultaneously. This module is ideal for users who want to output a variable voltage signal but do not want to use up their system board's analog capable pins.

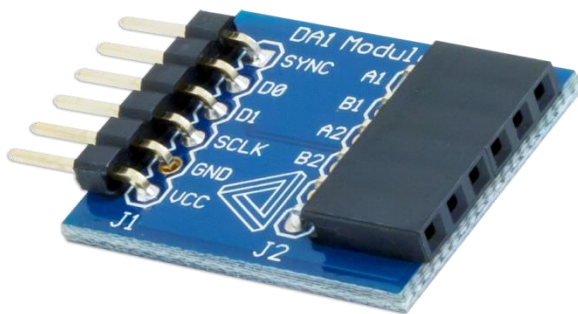

The PmodDA1.

Features include:

- Two 8-bit DACs
- Four D/A conversion channels
- Maximum conversion rate of 1.875 MSa
- Small PCB size for flexible designs 1.0" × 0.8" (2.5 cm × 2.0 cm)
- 6-pin Pmod connector with GPIO interface
- Library and example code available in [resource center](#)

1 Functional Description

The PmodDA1 converts an 8-bit digital input signal to a corresponding analog output voltage ranging from 0 to V_{dd}. Each of the two [AD7303s](#) on this Pmod have two 8-bit DACs allowing the user to select which DAC they want their stream of data to be passed through. Because each chip is double buffered, users may also choose to send two separate streams of data on an input and then update the two corresponding outputs simultaneously.

2 Interfacing with the Pmod

The PmodDA1 communicates with the host board via an SPI-like communication protocol. The difference between the standard SPI protocol and this protocol is manifested in the pin arrangement on this Pmod. A typical SPI interface would expect a Chip Select, a Master-Out-Slave-In, a Master-in-Slave-Out, and a Serial Clock signal. However, with the two DACs on this chip, both of the data lines (MOSI and MISO) are designed to operate only as inputs, making them both Master-Out-Slave-In data lines.

The PmodDA1 will receive its 8 bits of information from the system board through 16 clock cycles with first eight bits consisting of eight control bits and the remaining eight bits representing the 8 bits of the data with the MSB first. Each bit is received by the rising edge of the serial clock line. The function dictated by the first eight control bits is executed when the chip select line is brought high.

A pinout table and diagram for the PmodDA1 are provided below:

Header J1		
Pin	Signal	Description
1	~SYNC	Chip Select (active low)
2	D0	Input Data 1
3	D1	Input Data 2
4	SCK	Serial Clock
5	GND	Power Supply Ground
6	VCC	Power Supply (3.3V/5V)

Header J2		
Pin	Signal	Description
1	A1	Output Data A1
2	B1	Output Data B1
3	A2	Output Data A2
4	B2	Output Data B2
5	GND	Power Supply Ground
6	VCC	Positive Power Supply

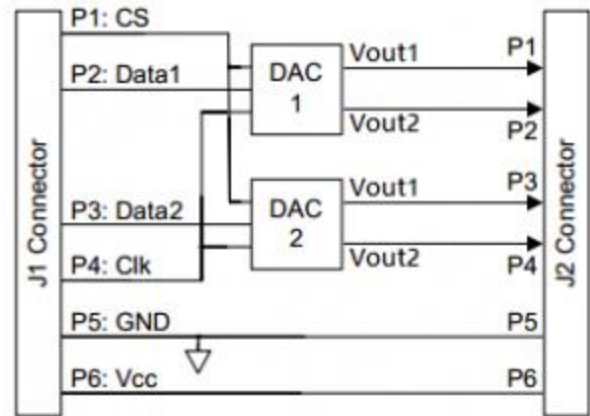

DA1 Circuit Diagram

Figure 1. PmodDA1 circuit diagram.

Table 1. Connector J1: Pin descriptions as labeled on the Pmod.

The on-board DACs can in principle use either an external or internal reference voltage; however, the PmodDA1 is designed that the internal reference voltage of $V_{dd}/2$ volts must be used. Because of this, the first bit in the command signal sent to the Pmod must always be a logic low signal in order to use the internal reference voltage on the DAC. Tables describing the command signal and the associated bits from the [AD7303 datasheet](#) are provided below.

Control Bits								Data Bits							
~INT/EXT	X	LDAC	PDB	PDA	~A/B	CR1	CR0	DB7	DB6	DB5	DB4	DB3	DB2	DB1	DB0
(MSB)								(LSB)							

Table 2. PmodDA1 input shift register structure.

Note: The "~" signifies that the signal is active when driven low.

Bite Name	Description
~INT/EXT	Selects between the internal and external voltage reference
X	Don't care
LDAC	Load DAC bit to both load and update the DAC outputs
PDB	Power-down DAC B
PDA	Power-down DAC A
~A/B	Selects either DAC A or DAC B to process the data
CR1	Works with CR0 as per the Control Bits Truth Table below
CR0	Works with CR1 as per the Control Bits Truth Table below
Data	The user submitted data where DB7 is the MSB and DB0 is the LSB

Table 3. Bit descriptions.

LDAC	~A/B	CR1	CR0	Resulting Operation
0	X	0	0	Both DAC registers loaded from the shift register
0	0	0	1	Update DAC A register from the shift register
0	1	0	1	Update DAC B register from the shift register
0	0	1	0	Update DAC A DAC register from the input register
0	1	1	0	Update DAC B DAC register from the input register
0	0	1	1	Update DAC A DAC register from the shift register
0	1	1	1	Update DAC B DAC register from the shift register
1	0	X	X	Load DAC A input register from the shift register and update both DAC registers
1	1	X	X	Load DAC B input register from the shift register and update both DAC registers

Table 4. Control bits truth table.

PDA	PDB	Description
0	0	Both DACs are active
0	1	DAC A is active and DAC B is in power-down mode
1	0	DAC B is active and DAC is in power-down mode
1	1	Both DACs are in power-down mode
~INT/EXT	Description	
0	Internal Vdd/2 reference voltage selected	
1	External reference voltage selected	

Table 5. Another truth table compiled from the AD7303 datasheet.

3 Physical Dimensions

The pins on the pin header are spaced 100 mil apart. The PCB is 1 inch long on the sides parallel to the pins on the pin header and 0.8 inches long on the sides perpendicular to the pin header.



Компания «ЭлектроПласт» предлагает заключение долгосрочных отношений при поставках импортных электронных компонентов на взаимовыгодных условиях!

Наши преимущества:

- Оперативные поставки широкого спектра электронных компонентов отечественного и импортного производства напрямую от производителей и с крупнейших мировых складов;
- Поставка более 17-ти миллионов наименований электронных компонентов;
- Поставка сложных, дефицитных, либо снятых с производства позиций;
- Оперативные сроки поставки под заказ (от 5 рабочих дней);
- Экспресс доставка в любую точку России;
- Техническая поддержка проекта, помощь в подборе аналогов, поставка прототипов;
- Система менеджмента качества сертифицирована по Международному стандарту ISO 9001;
- Лицензия ФСБ на осуществление работ с использованием сведений, составляющих государственную тайну;
- Поставка специализированных компонентов (Xilinx, Altera, Analog Devices, Intersil, Interpoint, Microsemi, Aeroflex, Peregrine, Syfer, Eurofarad, Texas Instrument, Miteq, Cobham, E2V, MA-COM, Hittite, Mini-Circuits, General Dynamics и др.);

Помимо этого, одним из направлений компании «ЭлектроПласт» является направление «Источники питания». Мы предлагаем Вам помощь Конструкторского отдела:

- Подбор оптимального решения, техническое обоснование при выборе компонента;
- Подбор аналогов;
- Консультации по применению компонента;
- Поставка образцов и прототипов;
- Техническая поддержка проекта;
- Защита от снятия компонента с производства.



Как с нами связаться

Телефон: 8 (812) 309 58 32 (многоканальный)

Факс: 8 (812) 320-02-42

Электронная почта: org@eplast1.ru

Адрес: 198099, г. Санкт-Петербург, ул. Калинина, дом 2, корпус 4, литера А.