

Ring Generator Controller IC

Features

- ▶ 3.3V operation, logic inputs 3.3V & 5.0V compatible
- ▶ Digital control of ring frequency, amplitude, and offset
- ▶ Control via 8-bit bus or via individual inputs
- ▶ 8 built-in ring frequencies: 12, $16\frac{2}{3}$, 20, 25, $33\frac{1}{3}$, 40, 50, 60Hz
- ▶ External ring frequency input
- ▶ Low distortion sine wave synthesizer
- ▶ AC-only, AC+DC, or DC-only ringer output
- ▶ Adjustable over-current protection
- ▶ Internal precision voltage references
- ▶ Power-on reset and undervoltage lockout for hotswap capability
- ▶ Sync output with adjustable lead time for synchronizing ringing relays
- ▶ Fault output for problem detection
- ▶ Open or closed loop operation
- ▶ Efficient 4-quadrant operation
- ▶ Zero-cross turn-on with zero-cross turn-off option

Applications

- ▶ PBX
- ▶ DLC
- ▶ Key Systems
- ▶ Remote Terminal
- ▶ Wireless Loop Systems

General Description

The HV461FG is a highly integrated ring generator controller IC, designed to work with a patented four-quadrant inverter topology, with synchronous rectifiers on the secondary side to achieve higher efficiencies. The inverter delivers the desired ring voltage from a standard -48V Telecom power supply.

The HV461 consists of a sine wave synthesizer that can provide eight different ring frequencies for universal applications. Any other frequency in the 12 to 63Hz range can be obtained by applying an external logic signal to the IC. A transparent latch permits control of the ringer output individually or through the 8-bit bus. The output amplitude and DC offset can be digitally controlled providing high flexibility to the designers. The patented inverter topology using the HV461 controller IC is capable of achieving higher efficiencies, typically over 80%, and drive up to a 40 REN load.

The controller allows ring generators to provide a floating 94VAC (rms) waveform that can be referenced to either the -48V or any other offset level by using the programmable offset pins of the IC. Output offset may be achieved by directly generating the offset within the power stage, or by floating the output stage on a DC source, or both.

The HV461 also has an internal boost converter that can be used to provide the gate drive voltages for the two MOSFETS on the primary side and the two secondary rectifiers on the secondary side.

Typical Application Circuit

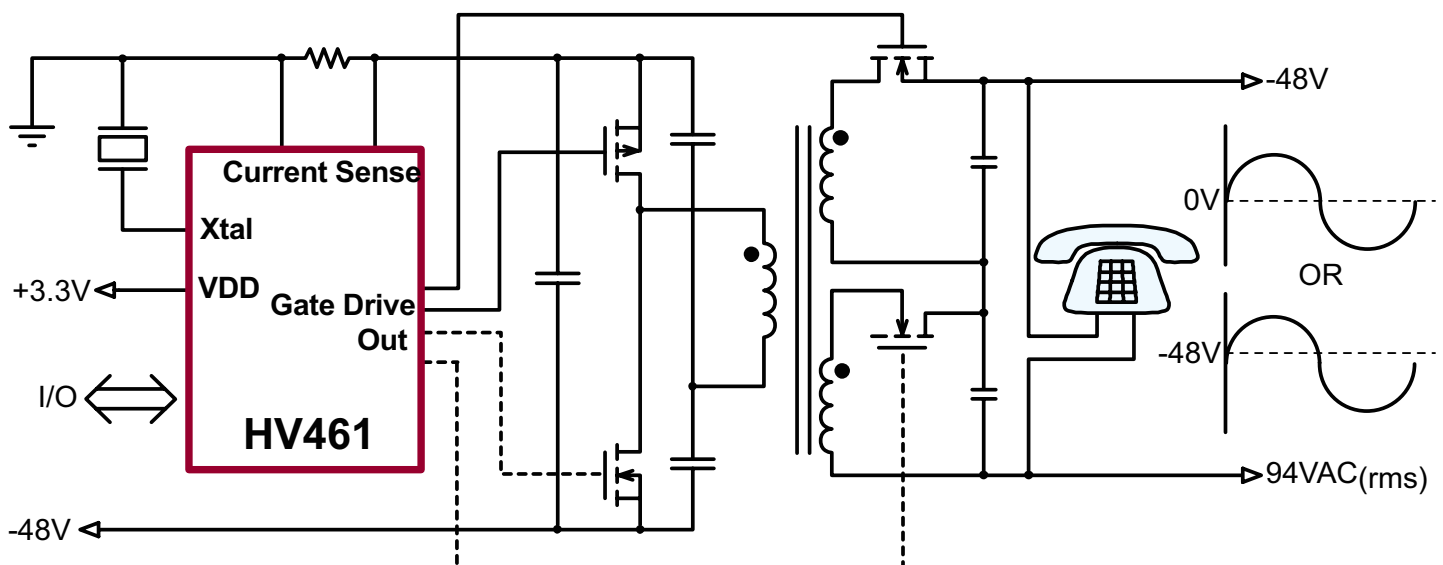

Ordering Information

Part Number	Package Option	Packing
HV461FG-G	48-Lead LQFP	250/Tray
HV461FG-G M931	48-Lead LQFP	1000/Reel

-G denotes a lead (Pb)-free / RoHS compliant package

Pin Configuration

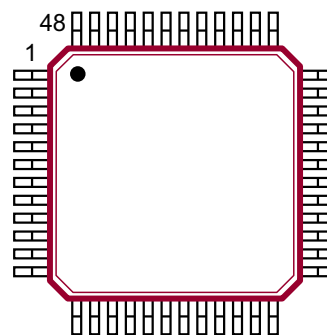

48-Lead LQFP
(top view)

Absolute Maximum Ratings

Parameter	Value
V_{DD}	+4.0V
Digital inputs	-0.5V to +7.0V
Analog inputs	-0.5V to +7.0V
Storage temperature	-65°C to +150°C
Operating temperature	-40°C to +85°C

Absolute Maximum Ratings are those values beyond which damage to the device may occur. Functional operation under these conditions is not implied. Continuous operation of the device at the absolute rating level may affect device reliability. All voltages are referenced to device ground.

Product Marking

Top Marking



YY = Year Sealed
 WW = Week Sealed
 L = Lot Number
 C = Country of Origin*
 A = Assembler ID*

Bottom Marking



— = "Green" Packaging
 *May be part of top marking

Package may or may not include the following marks: Si or

48-Lead LQFP

Typical Thermal Resistance

Package	θ_{ja}
48-Lead LQFP	52°C/W

Electrical Specifications (unless otherwise specified: $V_{DD} = 3.3V$, $T_A = -40^\circ C$ to $+85^\circ C$)

External Supply

Sym	Parameter	Min	Typ	Max	Units	Conditions
V_{DD}	Supply voltage	3.0	3.3	3.6	V	---
I_{DD}	Supply current ($AV_{DD} + DV_{DD}$)	-	7	30	mA	$f_{PWM} = 100kHz$ $f_{osc} = 19.6608MHz$ SW outputs NC Open loop config, External V_{GD}

Gate Drive Supply

Sym	Parameter	Min	Typ	Max	Units	Conditions
V_{GD}	Boost circuit voltage	9.0	9.6	10.2	V	---
I_{GD}	Gate drive supply current	-	-	5.0 10	mA	$V_{DD} = 2.97 - 3.63V$, SW outputs unloaded $V_{DD} = 2.50 - 2.93V$, SW outputs unloaded
$V_{DR(lo)}$	Drive voltage, low	-	-	0.2	V	$I_{OUT} = -10\mu A$
$V_{DR(hi)}$	Drive voltage, hi	$V_{DD} - 0.4$	-	-	V	$I_{OUT} = 10\mu A$
t_{RISE}	Rise time	-	-	100	ns	$C_L = 200pF$
t_{FALL}	Fall time	-	-	100	ns	$C_L = 200pF$
f_{GD}	Converter frequency	same as PWM				---
D_{GD}	Duty cycle	45	50	55	%	---

Voltage Reference

Sym	Parameter	Min	Typ	Max	Units	Conditions
V_{REF1}	Reference voltage 1	1.213	1.250	1.288	V	$T_a = 25^\circ\text{C}$
TC_{REF1}	Temperature coefficient	-	200	-	$\mu\text{V}/^\circ\text{C}$	---
ΔV_{ref1}	Output regulation	-6.25	-	+6.25	mV	$I_{out} = \pm 100\mu\text{A}$
V_{REF2}	Reference voltage 2	2.425	2.500	2.575	V	$T_A = 25^\circ\text{C}$
TC_{REF2}	Temperature coefficient	-	500	-	$\mu\text{V}/^\circ\text{C}$	---
ΔV_{ref2}	Output regulation	-12.5	-	0	mV	$I_{out} = 0 - 100\mu\text{A source}$

Logic Inputs

Sym	Parameter	Min	Typ	Max	Units	Conditions
$V_{IN(lo)}$	Input voltage low	-	-	$0.3 \cdot V_{DD}$	V	---
$V_{IN(hi)}$	Input voltage high	$0.7 \cdot V_{DD}$	-	-	V	---
$I_{IN(lo)}$	Input current low	-	-	-1	μA	$V_{IN} = 0\text{V}$
$I_{IN(hi)}$	Input current high	-	-	1	μA	$V_{IN} = 5.0\text{V}$
C_{IN}	Input capacitance	-	-	10	pF	---
t_S	Set-up time	-	-	100	ns	---
t_H	Hold time	-	-	100	ns	---

Reset

Sym	Parameter	Min	Typ	Max	Units	Conditions
$V_{RESET(ON)}$	RESET on voltage	1.200	1.325	1.450	V	---
$V_{RESET(OFF)}$	RESET off voltage	1.000	1.125	1.250	V	---
$V_{RESET(HYS)}$	RESET hysteresis	0.150	0.200	0.250	V	---
I_{P-UP}	RESET pull-up current	7.0	10.0	13.0	μA	---

Undervoltage Lockout

Sym	Parameter	Min	Typ	Max	Units	Conditions
$V_{DD(ON)}$	V_{DD} on voltage	2.75	2.85	2.95	V	---
$V_{DD(OFF)}$	V_{DD} off voltage	2.50	-	-	V	---
$V_{DD(HYS)}$	V_{DD} hysteresis	-	0.10	-	V	---
$V_{GD(ON)}$	V_{GD} on voltage	same as V_{GD} regulation point			V	---
$V_{GD(OFF)}$	V_{GD} off voltage	7.0	-	-	V	---
$V_{GD(HYS)}$	V_{GD} hysteresis	0.20	-	-	V	---

Fault Output

Sym	Parameter	Min	Typ	Max	Units	Conditions
V _{OUT(lo)}	Output voltage low	-	-	0.2	V	I _{OUT} = 1mA
K _{FAULT(on)}	FAULT on threshold	6	8	10	%*	C _{FAULT} = 10μF
K _{FAULT(off)}	FAULT off threshold	1	2	3	%*	C _{FAULT} = 10μF
t _{FAULT(hold)}	FAULT hold time	50	-	-	mS	C _{FAULT} = 10μF

* Percent of time PWM overrange or overcurrent is active.

Amplifiers

Sym	Parameter	Min	Typ	Max	Units	Conditions
V _{IN}	Input range	0.25	-	2.50	V	---
I _{IN}	Input bias current	-500	-	500	nA	V _{IN} = 0.5V to V _{DD} -0.5
V _{OFFSET}	Input offset voltage	-15	-	15	mV	---
V _{OUT(min)}	Min output	-	0.1	0.2	V	I _{OUT} = ±100uA
V _{OUT(max)}	Max output	V _{DD} -0.2	V _{DD} -0.1	-		I _{OUT} = ±100uA
A _{VOL}	Open loop gain	60	80	-	dB	---
CMRR	Common mode rejection ratio	-40	-60	-	dB	---
GBW	Gain-bandwidth product	1.0	-	-	MHz	---
SL	Slew rate	0.1	-	-	V/μs	---
PSRR	Power supply rejection ratio	-30	-	-	dB	f<10kHz

Sinewave Synthesizer

Sym	Parameter	Min	Typ	Max	Units	Conditions
V _{DC}	DC level	1.213	1.250	1.288	V	---
A	Amplitude	1.900	2.000	2.100 0	V _{P-P} V _{P-P}	AMP ≠ 00 AMP = 00
f ₀	Frequency	-	16 2/3	-	Hz	FREQ = 000, f _{OSC} = 19.6608MHz
f ₁	Frequency	-	20	-	Hz	FREQ = 001, f _{OSC} = 19.6608MHz
f ₂	Frequency	-	25	-	Hz	FREQ = 010, f _{OSC} = 19.6608MHz
f ₃	Frequency	-	30	-	Hz	FREQ = 011, f _{OSC} = 19.6608MHz
f ₄	Frequency	-	33 1/3	-	Hz	FREQ = 100, f _{OSC} = 19.6608MHz
f ₅	Frequency	-	40	-	Hz	FREQ = 101, f _{OSC} = 19.6608MHz
f ₆	Frequency	-	50	-	Hz	FREQ = 110, f _{OSC} = 19.6608MHz
f ₇	Frequency	-	60	-	Hz	FREQ = 111, f _{OSC} = 19.6608MHz
Δf	Frequency accuracy	-	-	0.1	%	f _{OSC} = 19.6608MHz
THD	Harmonic distortion	-	-	3	%	C _{SINE} = 33nF f _{ring} = 16 2/3 to 60Hz
R _{OUT}	Output resistance	14.4 72.0	16.0 80.0	17.6 88.0	kΩ kΩ	AMP ≠ 00 AMP = 00

External Ring Frequency

Sym	Parameter	Min	Typ	Max	Units	Conditions
$f_{CAP(lo)}$	Capture frequency low*	-	12	-	Hz	loop filter = (33 μ F+10k Ω) 4.7 μ F
$f_{CAP(hi)}$	Capture frequency high*	-	63	-	Hz	loop filter = (33 μ F+10k Ω) 4.7 μ F
$V_{IN(lo)}$	Input low	-	-	0.3 - V_{DD}	V	---
$V_{IN(hi)}$	Input high	0.7· V_{DD}	-	-	V	---
$\Delta\theta_{RING}$	Phase jitter, sine ref out	-5	-	+5	deg	loop filter = (33 μ F+10k Ω) 4.7 μ F

* Lock range is the same as capture range

Sine Reference Attenuator

Sym	Parameter	Min	Typ	Max	Units	Conditions
V_{DC}	DC level	1.213	1.250	1.288	V	$V_{IN(DC)} = 1.250V$
A_{OFF}	Attenuation	-	-	0.010	V/V	AMP = 00
A_{LO}	Attenuation	0.490	0.500	0.510	V/V	AMP = 01
A_{MED}	Attenuation	0.735	0.750	0.765	V/V	AMP = 10
A_{HI}	Attenuation	0.980	1.000	1.020	V/V	AMP = 11
V_{IN}	Input range	0.2	-	$V_{DD} - 0.2$	V	---

DC REF Multiplexer

Sym	Parameter	Min	Typ	Max	Units	Conditions
V_{IN}	Input range	0.0	-	V_{DD}	V	---
I_{IN}	Input bias current	-500	-	+500	nA	---
I_{OFF}	Off leakage current	-	-	1.0	μ A	$V_{IN} = 0.5$ to $V_{DD} - 0.5V$

Enable and SYNC

Sym	Parameter	Min	Typ	Max	Units	Conditions
$V_{OUT(lo)}$	SYNC output voltage low	-	-	0.2	V	$I_{OUT} = 1.0mA$ sink
$V_{OUT(hi)}$	SYNC output voltage high	$V_{DD} - 0.2$	-	-	V	$I_{OUT} = 1.0mA$ source
t_{ON}	ENABLE delay, on	-	-	5	μ s	---
t_{OFF}	ENABLE delay, off	0	-	60 1	μ s ring cycle	SYNCMODE = 0 SYNCMODE = 1
$T_{SYNC(ON)}$	SYNC on lead time	4.5	5.0	5.5	ms	$C_{SINE} = 0$ $R_{SYNC} = 154k\Omega$ $C_{SYNC} = 47nF$
$T_{SYNC(OFF)}$	SYNC off delay	-250	0	+250	μ s	$C_{SINE} = 10nF$
$t_{SYNC(rise)}$	SYNC rise time	-	-	300	ns	$C_L = 50pF$
$t_{SYNC(fall)}$	SYNC fall time	-	-	300	ns	$C_L = 50pF$

PWM Controller

Sym	Parameter	Min	Typ	Max	Units	Conditions
-----	-----------	-----	-----	-----	-------	------------

PWM Frequency

f_{PWM}	PWM frequency	21.25 127.5	25.00 150.0	28.75 172.5	kHz kHz	$R_{\text{PWM}} = 500\text{k}\Omega$ $R_{\text{PWM}} = 83\text{k}\Omega$
$t_{\text{PWMSYNC(OUT)}}$	PWM sync output pulse width	30	50	70	ns	---
$t_{\text{PWMSYNC(IN)}}$	PWM sync input pulse width	25	-	-	ns	---
$f_{\text{PWMSYNC(IN)}}$	PWM sync input frequency range	25	-	150	kHz	---
$V_{\text{PWMSYNC(lo)}}$	PWM sync output low voltage	-	-	0.2	V	$I_{\text{OUT}} = 1.0\text{mA sink}$
I_{PWMSYNC}	PWM sync pull-up current	-	100	-	μA	---

Switch Driver Outputs

$V_{\text{OUT(lo)}}$	Output voltage, low	-	-	0.2	V	$I_{\text{OUT}} = 20\text{mA sink}$
$V_{\text{OUT(hi)}}$	Output voltage, high	$V_{\text{GD}} - 0.2$	-	-	V	$I_{\text{OUT}} = 20\text{mA source}$
t_{RISE}	Rise time	-	-	50	ns	$C_{\text{L}} = 4\text{nF}$
t_{FALL}	Fall time	-	-	50	ns	$C_{\text{L}} = 4\text{nF}$

Timing

D	Duty cycle	23 48 73	25 50 75	27 52 77	% % %	$\text{PWM}_{\text{IN}} = 0.625\text{V}$ $\text{PWM}_{\text{IN}} = 1.250\text{V}$ $\text{PWM}_{\text{IN}} = 1.875\text{V}$ $V_{\text{DCL}} = 0\text{V}$
D_{limit}	Duty cycle limit	12 72 22 62	20 80 30 70	28 88 38 78	% % % %	$V_{\text{DCL}} = 0.50\text{V}, \text{PWM}_{\text{IN}} = 0\text{V}$ $V_{\text{DCL}} = 0.50\text{V}, \text{PWM}_{\text{IN}} = 2.5\text{V}$ $V_{\text{DCL}} = 0.75\text{V}, \text{PWM}_{\text{IN}} = 0\text{V}$ $V_{\text{DCL}} = 0.75\text{V}, \text{PWM}_{\text{IN}} = 2.5\text{V}$
I_{DCL}	V_{DCL} input current	-	-	1.0	μA	$V_{\text{DCL}} = 0 - 1.0\text{V}$
t_{DB}	Primary switch deadband	0 0.95	100 1.00	150 1.05	ns μs	$C_{\text{DB}} = 0\text{pF}$ $R_{\text{DB}} = 14\text{k}\Omega, C_{\text{DB}} = 100\text{pF}$
t_{DLY}	Secondary switch delay	0 0.95	100 1.00	150 1.05	ns μs	$C_{\text{DLY}} = 0\text{pF}$ $R_{\text{DLY}} = 14\text{k}\Omega, C_{\text{DLY}} = 100\text{pF}$

Switch Outputs

ENABLE	AMP	OFF	SW1	SW2	SW3	SW4
0	00	XX	Off	Off	Off	Off
0	≠00	XX	Off	Off	Switching	Switching
1	XX	XX	Switching	Switching	Switching	Switching

X = don't care, #00 = 01, 10, or 11

Figure 1: Switch Timing Diagram

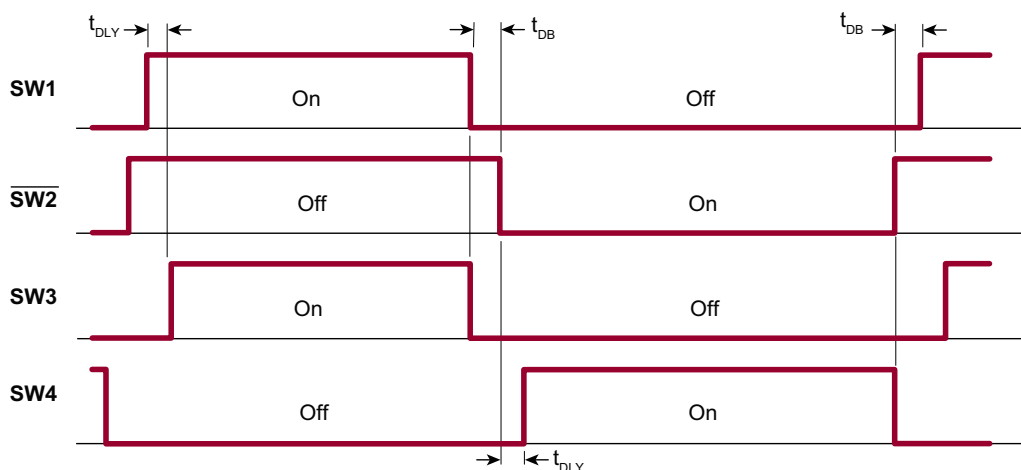

Figure 2: ENABLE and SYNC Timing - SYNCMODE = 0

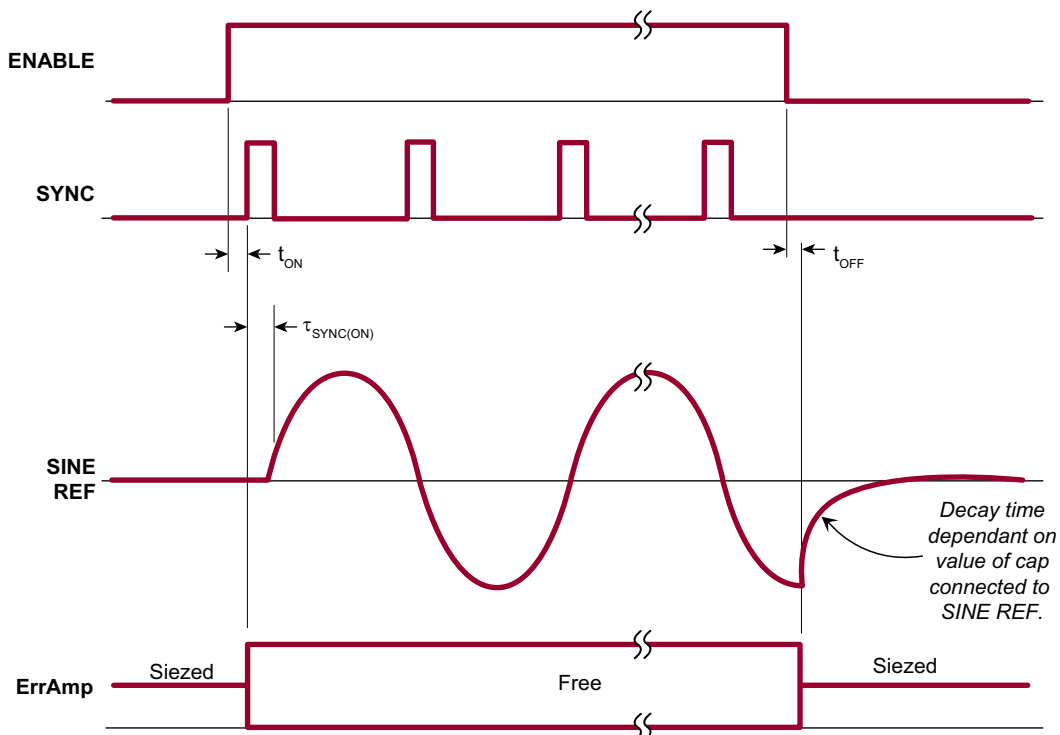

Figure 3: ENABLE and SYNC Timing - SYNCMODE = 1

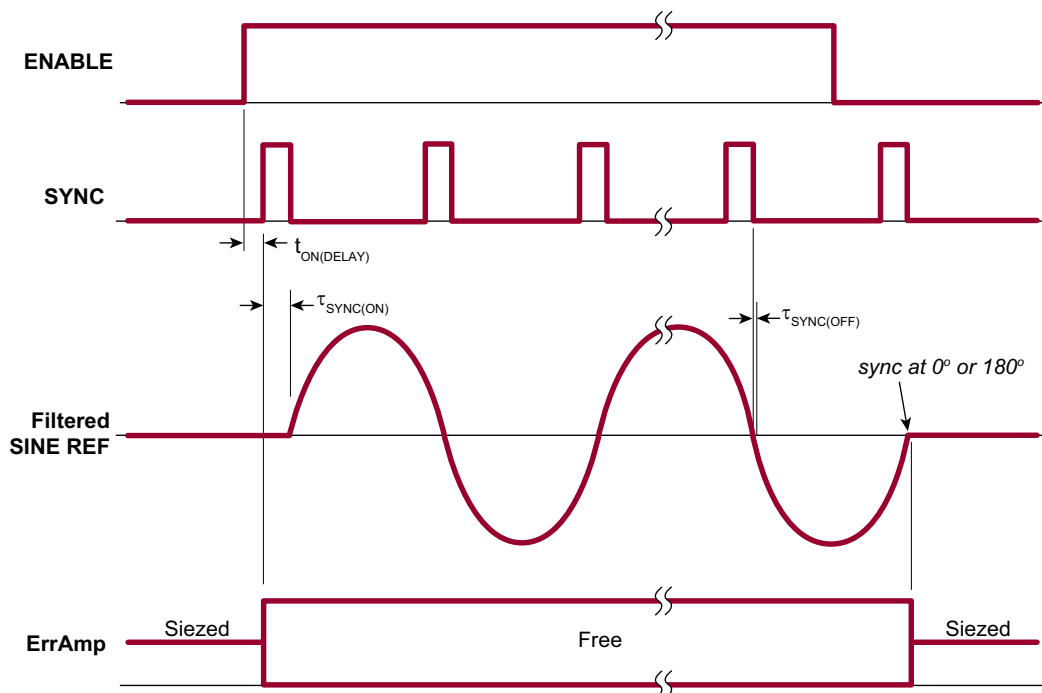
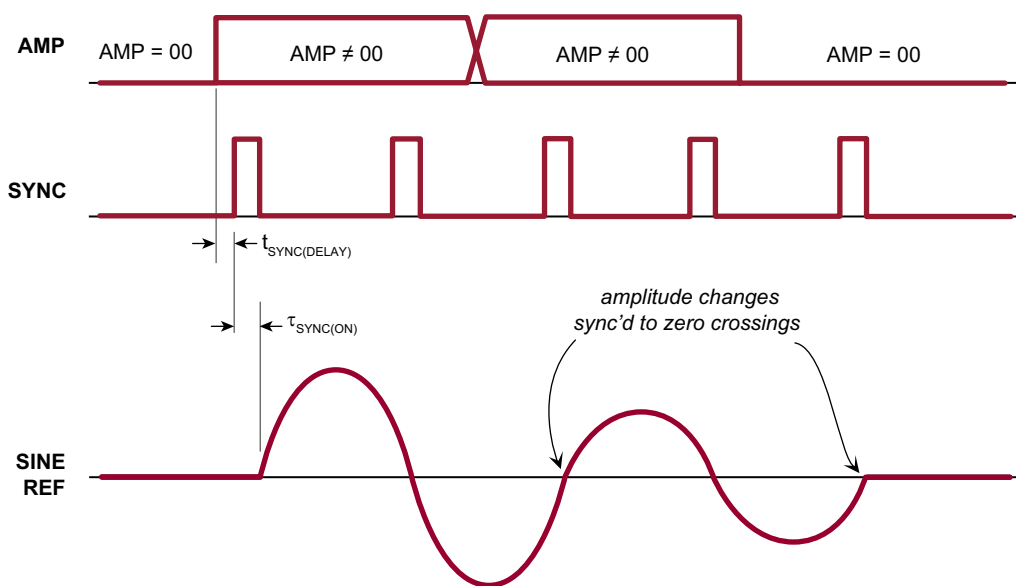

Figure 4: AMP Timing



Typical Application

Figures 5 and 6 on pages 9 and 10 show the schematic of a typical 15 REN ring generator application. The basic design equations for elements connected to different pins are given in the Pin Descriptions Table beginning on page 11.

Figure 5: Block Diagram and Typical Application Circuit

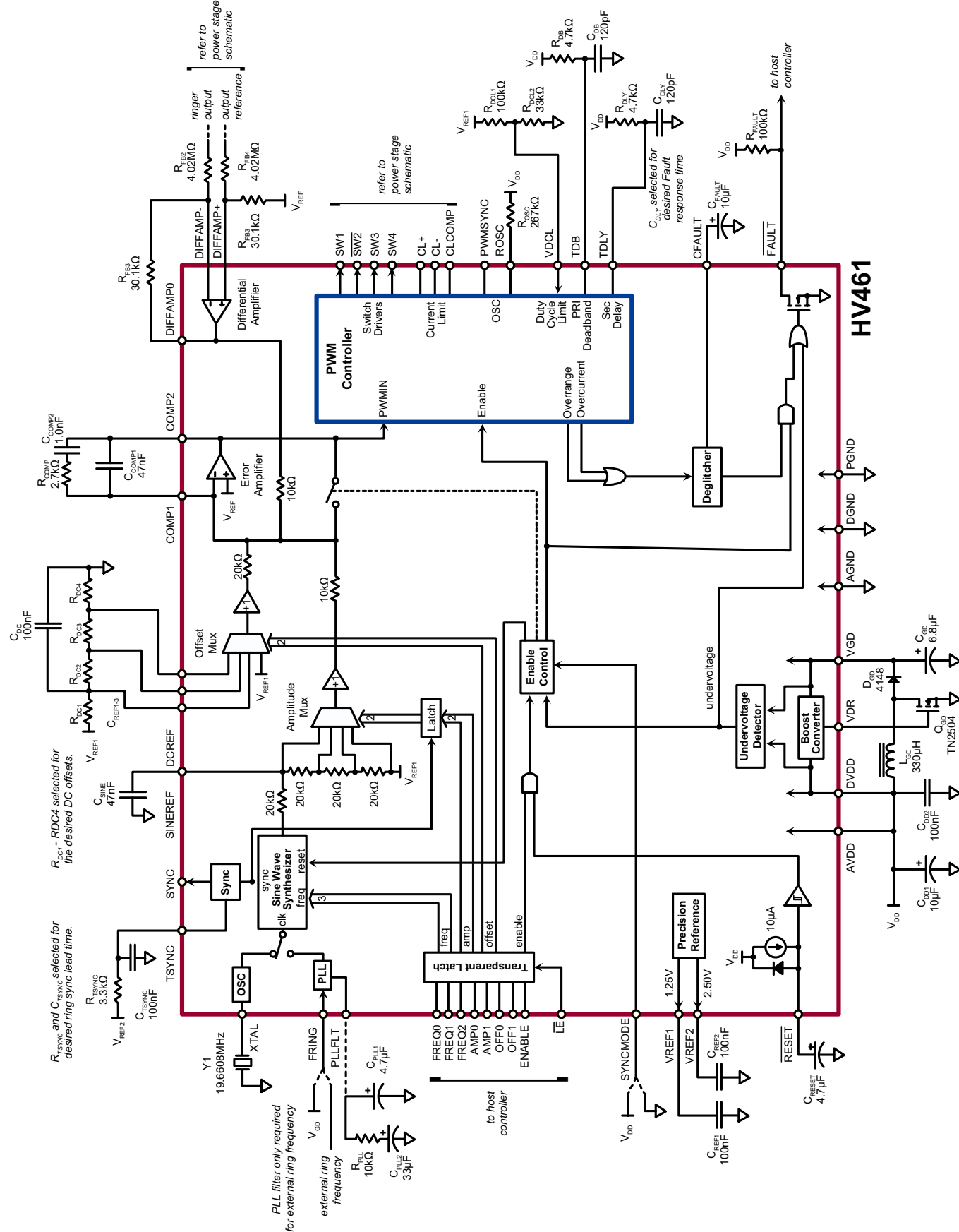
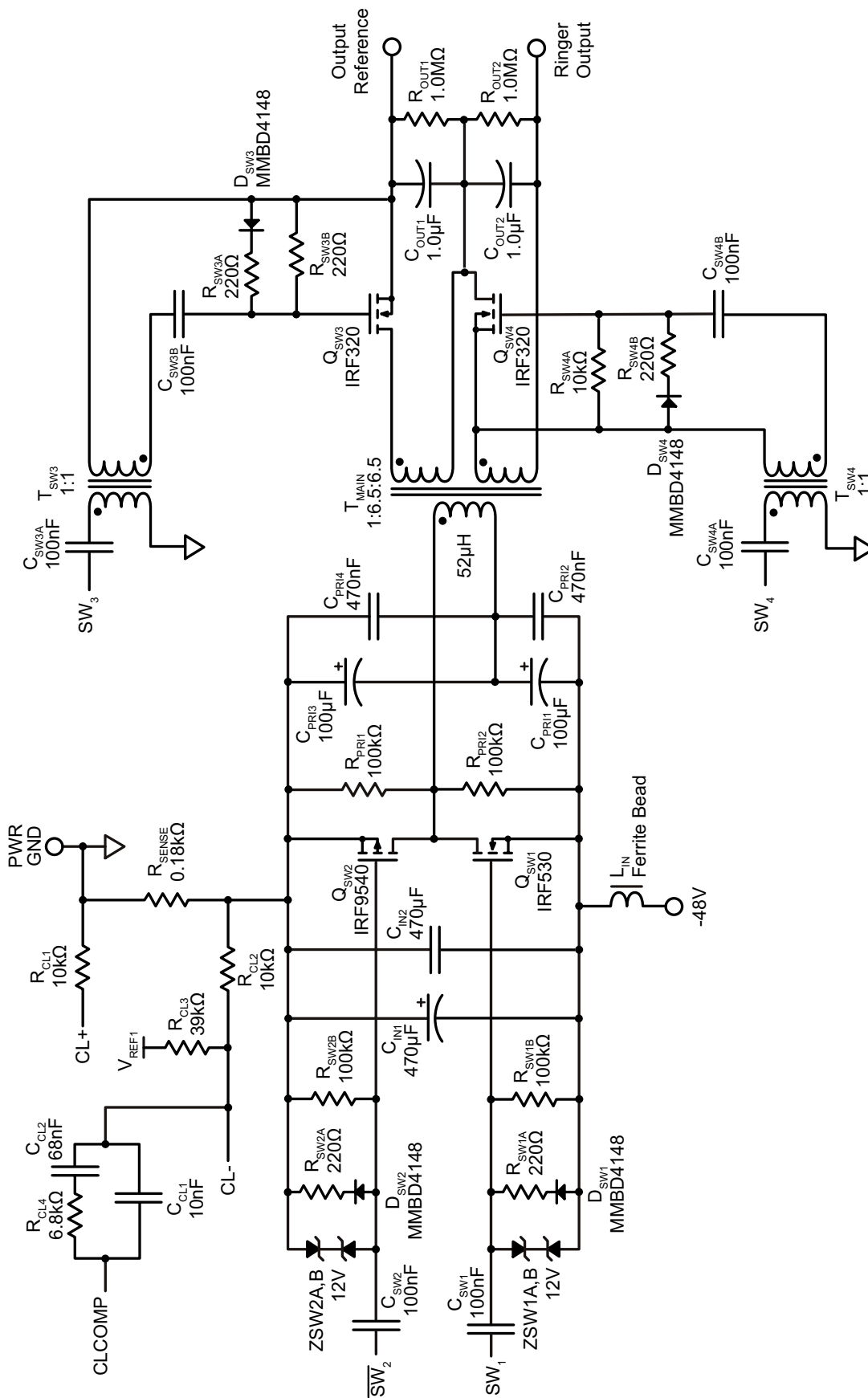

Figure 6: Typical Power Stage for 15 REN Ring Generator



Pin Description *(refer to pin configuration on page 2)*

Pin	Name	Description
1	DCREF3	See DCREF1 and DCREF2 (pins 47 & 48).
2	VREF1	Outputs a 1.25V nominal reference voltage. Bypass with a 100nF capacitor to ground.
3	VREF2	Outputs a 2.50V nominal reference voltage. Bypass with a 100nF capacitor to ground.
4	AVDD	Supply for the analog section. 3.0 to 3.6V Must be from the same source as DVDD. Bypass with a 100nF capacitor to ground as close as possible to the IC.
5	TSYNC	An RC network connected to this pin determines the SYNC pulse lead time (see SYNC pin 14). $t_{LEAD} = 0.48RC$ If SYNC is not utilized, TSYNC must still have a connected RC network.
6	XTAL	A crystal from this pin to ground provides the frequency reference for the internal sine wave synthesizer. A 19.6608MHz baud rate crystal provides the 8 most common ring frequencies. The crystal is operated in the series mode. A loading capacitor is not necessary. See also FREQ0–2 (pins 21–23) and FRING (pin 7).
7	FRING	Ring frequency is normally selected from the 8 built-in frequencies using control inputs FREQ0–2. Other arbitrary frequencies in the range of 12 to 63Hz may be obtained by applying an external signal to FRING. This external signal sets the ring frequency at a 1:1 ratio. The ring signal remains a sine wave, with amplitude and offset still controlled via AMPx and OFFx. The ring signal, while frequency locked to the FRING signal, is not phase-synchronized to it. This allows the ring signal to immediately start at 0° when enabled via ENABLE or AMP ≠ 00. When unused, this input must be connected to VGD.
8	PLLFLT	Phase locked loop filter. An RC network connected to this pin stabilizes the PLL that locks on to the optional external ring frequency signal. (See FRING, pin 7) The RC network determines the lock time of the PLL. Due to the low frequencies involved, it may take a couple seconds to lock to the external signal. See the typical application schematic for typical values. When unused, this pin should be left unconnected.
9	ROSC	A resistor from this pin to VDD sets the PWM frequency. $f_{PWM} \approx 12.5\text{GHz}\Omega / R_{OSC}$ (valid for 20-150kHz)
10	$\overline{\text{RESET}}$	A capacitor from this pin to ground provides a power-on reset interval. It has an internal 10μA pull-up to charge the external reset capacitor. Alternatively, an external logic-level or open-drain signal may be applied to implement the reset function. During the reset interval when $V_{RESET} < 1.325\text{V}$, the ringer output is disabled regardless of the state of the ENABLE input, allowing time for the host controller to assume control. Use a low leakage tantalum or ceramic capacitor. $t_{RESET} = 1.325\text{V} \cdot C_{RESET} / 10\mu\text{A}$
11	PWMSYNC	This pin functions as both an input and an output. It is open-drain with an internal 100μA pull-up. As an output, it provides a short, low-going pulse at the internal PWM frequency. As an input, it synchronizes internal PWM frequency to the externally applied signal, provided the external signal is at a higher frequency. The low-going applied sync pulse should be between 25ns and less than the PWM period in duration. The external source should be open drain. If the PWMSYNC pins of multiple HV461s are tied together, their PWM frequencies will be phase-locked to the HV461 with the highest free-running frequency. A maximum of 10 HV461s may be tied together. If unused, this pin should be left unconnected.
12	CFAULT	A capacitor from this pin to ground sets the integration time of the FAULT detection circuitry. A larger capacitor provides less susceptibility to transient problems, while a smaller capacitor provides quicker response. Values in the range of 1μF to 100μF are appropriate. If the FAULT output is not used, this pin should be grounded. See also FAULT (pin 15).

Pin Description (cont.)

Pin	Name	Description
13	SYNCMODE	With SYNCMODE low, ringer output ceases the instant ENABLE goes low. When high, ringer output ceases at the next ring signal phase crossing (0°/180°) after ENABLE goes low.
14	SYNC	Outputs a pulse indicating sine reference 0° and 180° phase crossing (not to be confused with zero-voltage crossing). The rising edge precedes phase crossing by a user-adjustable time period (see TSYNC pin 44). Falling edge coincides with sine reference phase crossing. SYNC is digitally derived, therefore phase shifts caused by the external filter capacitor at SINEREF will not be reflected at the SYNC output.
15	$\overline{\text{FAULT}}$	Indicates abnormal operating conditions of output overcurrent, supply undervoltage (VDD & VGD), or PWM overrange (duty cycle limit – see VDCL, pin 3). Together, these 3 conditions catch most any problem. When an overcurrent or overrange condition exists for more than 8% of the time, this output becomes active. It is cleared when the problem occurs less than 2% of the time. Undervoltage conditions immediately activate the FAULT output. It is active low and open drain to allow wire-ORing. See CFAULT (pin 15) for additional information.
16	ENABLE	Ringer output enable. Active high. When enabled, the ring signal always starts immediately at 0 degrees. If AMP≠00, SW1 and SW2 are held off when ENABLE=0 but SW3 and SW4 continue switching. If AMP=00, SW3 and SW4 are held off as well. When disabled, the error amplifier is set at unity gain to prevent saturation, reducing turn-on glitches when re-enabled. See SYNCMODE (pin 13) for additional information.
17	OFF0	Sets ring DC offset. Offset changes are effected at the next phase crossing (0°/180°) of the ring signal. Except for 00, offsets are set by the voltages at DCREFX1–3. (OFF0 is LSB) Offset = $\frac{1}{2} \times \text{Gain} \times (V_{\text{DCREFx}} - V_{\text{REF1}})$
18	OFF1	00 = 0V 01 = DCREFX1 10 = DCREFX2 11 = DCREFX3
19	AMP0	Sets ring amplitude. Amplitude changes are effected at the next phase crossing (0°/180°) of the ring signal. Amplitudes, as a percentage of full scale, are: (AMP0 is LSB)
20	AMP1	Full scale amplitude = $0.707V_{\text{RMS}} \times \text{Gain}$ 00 = 0% 01 = 50% 10 = 75% 11 = 100%
21	FREQ0	Sets ring frequency. Frequency changes are effected at the next phase crossing (0°/180°) of the ring signal.
22	FREQ1	Frequencies when using a 19.6608MHz crystal are: (FREQ0 is LSB)
23	FREQ2	000 = 16.7Hz 001 = 20Hz 010 = 25Hz 011 = 30Hz 100 = 33.3Hz 101 = 40Hz 110 = 50Hz 111 = 60Hz
24	$\overline{\text{LE}}$	Latch enable. The latch gates control inputs FREQ0–2, AMP0–1, OFF0–1, and ENABLE. When LE is high, latch outputs follow inputs. On a low-going transition, outputs are latched.
25	TDLY	An RC network on this pin sets the primary to secondary switch delay. This prevents the secondary-side switches (SW3&4) from turning on prematurely. $t_{\text{DLY}} = 0.48\text{RC}$
26	TDB	An RC network on this pin sets the deadband (break-before-make time) on the primary-side switches (SW1&2). Deadband prevents both switches from conducting simultaneously. $t_{\text{DB}} = 0.48\text{RC}$
27	DGND	Digital ground. Connect to AGND and PGND close to the IC.
28	SW4	Secondary-side switch driver output.
29	SW3	Secondary-side switch driver output.
30	SW2	Primary-side N-channel switch driver output.

Pin Description (cont.)

Pin	Name	Description	
31	SW1	Primary-side P-channel switch driver output.	
32	PGND	Power ground. Connect to AGND and DGND close to the IC.	
33	VGD	Supply for the SW1–4 drivers. An external boost converter controlled by VDR provides 9.6V for driving the power stage MOSFETs. An undervoltage condition on this supply pin disables ringer output and activates the FAULT output.	
34	VDR	Gate drive for the external boost converter circuit. Outputs a fixed 50% duty cycle at the ringer PWM frequency (see ROSC, pin 9). Output voltage regulation is via burp-mode operation. This output is bootstrapped to VGD, thus during startup VDR amplitude is VDD and after startup is VGD. (See VGD, pin 33)	
35	DVDD	Supply for the digital section. 3.0V to 3.6V input. Undervoltage disables ringer output. Must be from the same source as AVDD. Bypass with a 100nF capacitor to ground as close as possible to the IC. An undervoltage condition on this supply pin disables ringer output and activates the FAULT output.	
36	CL+	Current limit amplifier non-inverting input.	
37	CL-	Current limit amplifier inverting input.	
38	CLCOMP	Current limit compensation. An RC network connected between this pin and CL- establishes current limit reaction time and stability.	
39	DIFFAMP+	Differential amplifier non-inverting input.	<p>The differential amplifier sets gain, establishing output amplitude and DC offset in conjunction with AMPx and OFFx.</p> <p>Gain = R_{FB2}/R_{FB1}</p> <p>($R_{FB3} = R_{FB1}$ and $R_{FB4} = R_{FB2}$, see schematic)</p>
40	DIFFAMP-	Differential amplifier inverting input.	
41	DIFFAMPO	Differential amplifier output.	
42	COMP2	Error amplifier compensation. An RC network connected between these pins establishes loop stability.	
43	COMP1	COMP1 is the error amp inverting input. COMP2 is the error amp output.	
44	SINEREF	Sine wave reference. Amplitude is $2V_{P,P}$ nominal. Output impedance is approximately 16k Ω . An external 33nF capacitor from this pin to ground should be employed to remove high frequency synthesizer ripple. Synthesizer ripple is at a frequency of $2^{15} \cdot f_{RING}$	
45	AGND	Analog ground. Connect to AGND and DGND close to the IC.	
46	VDCL	Voltage applied to this pin sets the min/max duty cycle limits. If the PWM controller hits these limits, clipping of the ringer output will occur and the FAULT output will be activated. $D_{MIN} = 0.4V_{DCL}$ $D_{MAX} = 1 - 0.4V_{DCL}$	
47	DCREF1	In conjunction with the OFFx control inputs, voltages applied to these inputs set the output DC offset. Output offset is the selected DCREFx voltage multiplied by gain. See also OFF0 & OFF1 (pins 17 & 18)	
48	DCREF2		

48-Lead LQFP Package Outline (FG)

7.00x7.00mm body, 1.60mm height (max), 0.50mm pitch

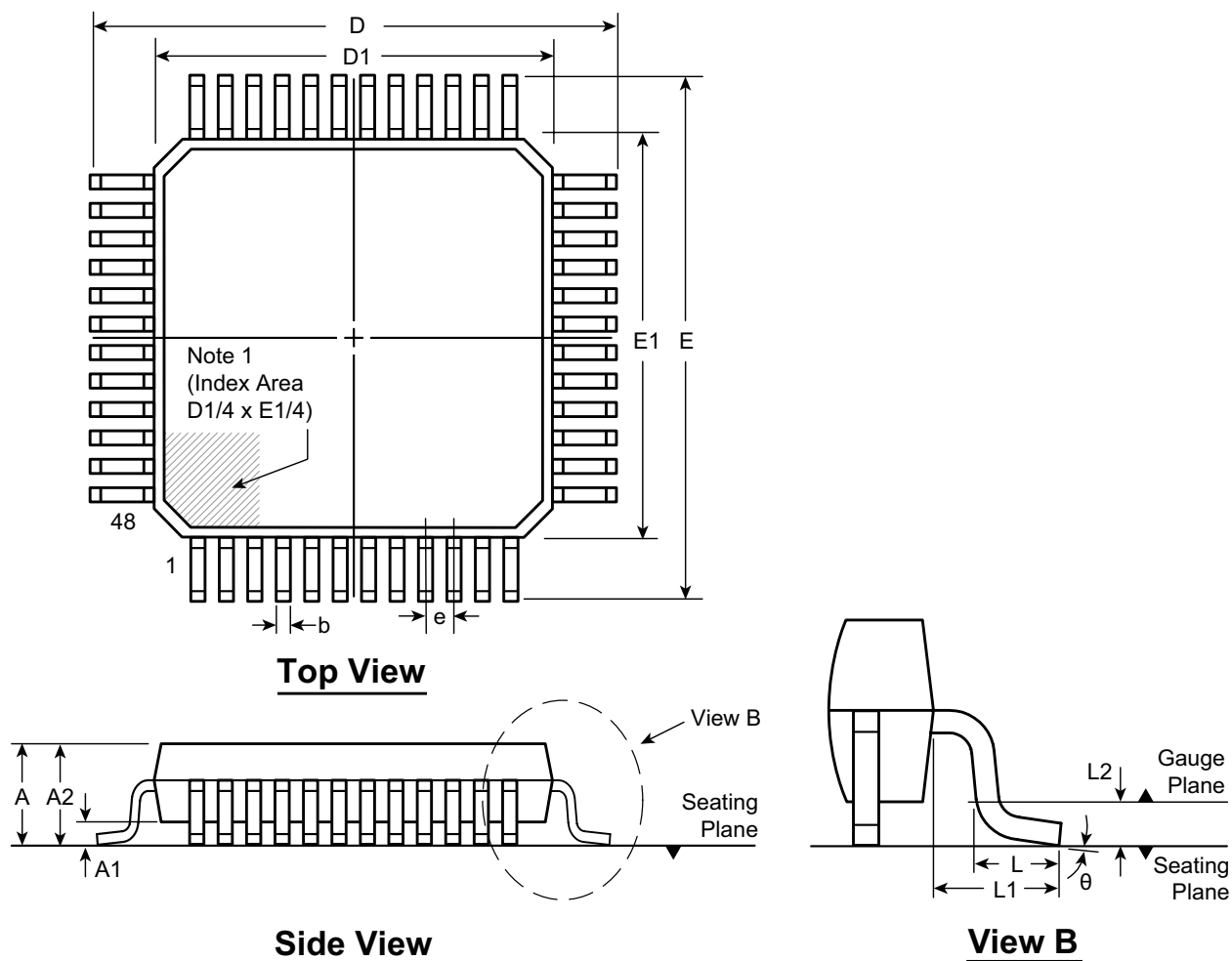

Note:
 1. A Pin 1 identifier must be located in the index area indicated. The Pin 1 identifier can be: a molded mark/identifier; an embedded metal marker; or a printed indicator.

Symbol	A	A1	A2	b	D	D1	E	E1	e	L	L1	L2	θ	
Dimension (mm)	MIN	1.40*	0.05	1.35	0.17	8.80*	6.80*	8.80*	6.80*	0.50 BSC	0.45	1.00 REF	0.25 BSC	0°
	NOM	-	-	1.40	0.22	9.00	7.00	9.00	7.00		0.60		3.5°	
	MAX	1.60	0.15	1.45	0.27	9.20*	7.20*	9.20*	7.20*		0.75		7°	

JEDEC Registration MS-026, Variation BBC, Issue D, Jan. 2001.
 * This dimension is not specified in the JEDEC drawing.

Drawings are not to scale.
Supertex Doc. #: DSPD-48LQFPFG Version, D041309.

(The package drawing(s) in this data sheet may not reflect the most current specifications. For the latest package outline information go to <http://www.supertex.com/packaging.html>.)

Supertex inc. does not recommend the use of its products in life support applications, and will not knowingly sell them for use in such applications unless it receives an adequate "product liability indemnification insurance agreement." **Supertex inc.** does not assume responsibility for use of devices described, and limits its liability to the replacement of the devices determined defective due to workmanship. No responsibility is assumed for possible omissions and inaccuracies. Circuitry and specifications are subject to change without notice. For the latest product specifications refer to the **Supertex inc.** (website: <http://www.supertex.com>)



Компания «ЭлектроПласт» предлагает заключение долгосрочных отношений при поставках импортных электронных компонентов на взаимовыгодных условиях!

Наши преимущества:

- Оперативные поставки широкого спектра электронных компонентов отечественного и импортного производства напрямую от производителей и с крупнейших мировых складов;
- Поставка более 17-ти миллионов наименований электронных компонентов;
- Поставка сложных, дефицитных, либо снятых с производства позиций;
- Оперативные сроки поставки под заказ (от 5 рабочих дней);
- Экспресс доставка в любую точку России;
- Техническая поддержка проекта, помощь в подборе аналогов, поставка прототипов;
- Система менеджмента качества сертифицирована по Международному стандарту ISO 9001;
- Лицензия ФСБ на осуществление работ с использованием сведений, составляющих государственную тайну;
- Поставка специализированных компонентов (Xilinx, Altera, Analog Devices, Intersil, Interpoint, Microsemi, Aeroflex, Peregrine, Syfer, Eurofarad, Texas Instrument, Miteq, Cobham, E2V, MA-COM, Hittite, Mini-Circuits, General Dynamics и др.);

Помимо этого, одним из направлений компании «ЭлектроПласт» является направление «Источники питания». Мы предлагаем Вам помощь Конструкторского отдела:

- Подбор оптимального решения, техническое обоснование при выборе компонента;
- Подбор аналогов;
- Консультации по применению компонента;
- Поставка образцов и прототипов;
- Техническая поддержка проекта;
- Защита от снятия компонента с производства.



Как с нами связаться

Телефон: 8 (812) 309 58 32 (многоканальный)

Факс: 8 (812) 320-02-42

Электронная почта: org@eplast1.ru

Адрес: 198099, г. Санкт-Петербург, ул. Калинина, дом 2, корпус 4, литера А.