

NCL30002

Power Factor Corrected Buck LED Driver

The NCL30002 is a switch mode power supply controller intended for low to medium power single stage power factor (PF) corrected LED Drivers. The device operates as a critical conduction mode (CrM) buck controller to regulate LED current at a high power factor for a specific line voltage range. The current limit threshold is tightly trimmed allowing open loop control techniques to reduce parts count while maintaining accurate current regulation and high power factor. CrM operation is particularly suited for LED applications as very high efficiency can be achieved even at low power levels. These are important in LED lighting to comply with regulatory requirements and meet overall system luminous efficacy requirements. In CrM, the switching frequency will vary with line and load. Switching losses are low as recovery losses in the output rectifier are negligible since the current goes to zero prior to reactivating the main MOSFET switch.

The device features a programmable on time limiter, zero current detect sense block, gate driver, trans-conductance error amplifier as well as all PWM control circuitry and protection functions required to implement a CrM switch mode power supply. Moreover, for high efficiency, the device features low startup current enabling fast, low loss charging of the V_{CC} capacitor. The current sense protection threshold has been set at 485 mV to minimize power dissipation in the external sense resistor. To support the environmental operation range of Solid State Lighting, the device is specified across a wide junction temperature range of -40°C to 125°C .

Features

- Very Low 24 μA Typical Startup Current
- Cycle-by-Cycle Current Protection
- Tightly Trimmed Low Current Sense Threshold of 485 mV $\pm 2\%$
- Low 2 mA Typical Operating Current
- Source 500 mA / Sink 800 mA Totem Pole Gate Driver
- Wide Operating Temperature Range
- Enable Function and Overvoltage Protection
- These Devices are Pb-Free, Halogen Free/BFR Free and are RoHS Compliant

Typical Applications

- LED Driver Power Supplies
- LED Based Bulbs
- Commercial and Residential LED Fixtures



ON Semiconductor®

<http://onsemi.com>



SOIC-8
D SUFFIX
CASE 751

MARKING DIAGRAM

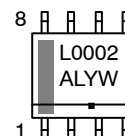

A = Assembly Location
L = Wafer Lot
Y = Year
W = Work Week
▪ = Pb-Free Package

PIN CONNECTION

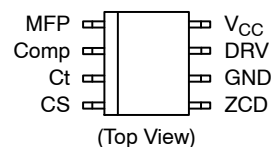

ORDERING INFORMATION

Device	Package	Shipping†
NCL30002DR2G	SOIC-8 (Pb-Free)	2500 / Tape & Reel

†For information on tape and reel specifications, including part orientation and tape sizes, please refer to our Tape and Reel Packaging Specifications Brochure, BRD8011/D.

NCL30002

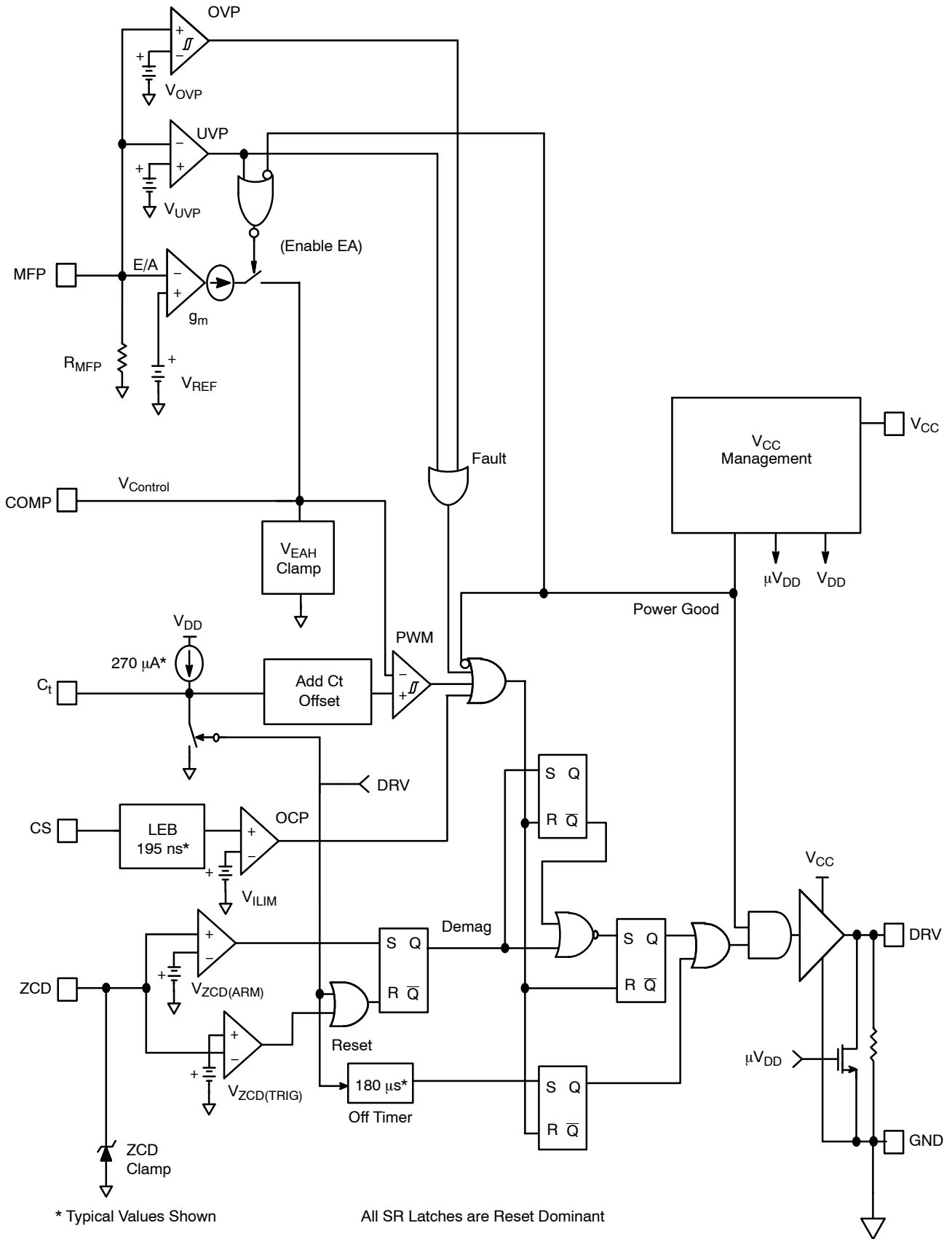

Figure 1. Block Diagram

NCL30002

Table 1. PIN FUNCTION DESCRIPTION

Pin	Name	Function
1	MFP	The multi-function pin is connected to the internal error amplifier. By pulling this pin below the V_{LVP} threshold, the controller is disabled. In addition, this pin also has an over voltage comparator which will disable the controller in the event of a fault.
2	COMP	The COMP pin is the output of the internal error amplifier. A compensation network connected between this pin and ground sets the loop bandwidth.
3	C_t	The C_t pin sources a regulated current to charge an external timing capacitor. The PWM circuit controls the power switch on time by comparing the C_t voltage to an internal voltage derived from $V_{Control}$. The C_T pin discharges the external timing capacitor at the end of the on time cycle.
4	CS	The CS input threshold is precisely trimmed to accurately sense the instantaneous switch current in the external MOSFET. This signal is conditioned by an internal leading edge blanking circuit. The current limit threshold is tightly trimmed for precise peak current control.
5	ZCD	The voltage of an auxiliary zero current detection winding is sensed at this pin. When the ZCD control block circuit detects that the winding current has gone to zero, a control signal is sent to the gate drive block to turn on the external MOSFET.
6	GND	This is the analog ground for the device. All bypassing components should be connected to the GND pin with a short trace length.
7	DRV	The high current capability of the totem pole gate drive (+0.5/-0.8 A) makes it suitable to effectively drive high gate charge power MOSFETs. The driver stage provides both passive and active pull down circuits that force the output to a voltage less than the turn-on threshold voltage of the power MOSFET when $V_{CC(on)}$ is not reached.
8	V_{CC}	This pin is the positive supply of the controller. The circuit starts to operate when V_{CC} exceeds $V_{CC(on)}$, nominally 12 V and turns off when V_{CC} goes below $V_{CC(off)}$, typically 9.5 V. After startup, the operating range is 10.2 V up to 20 V.

NCL30002

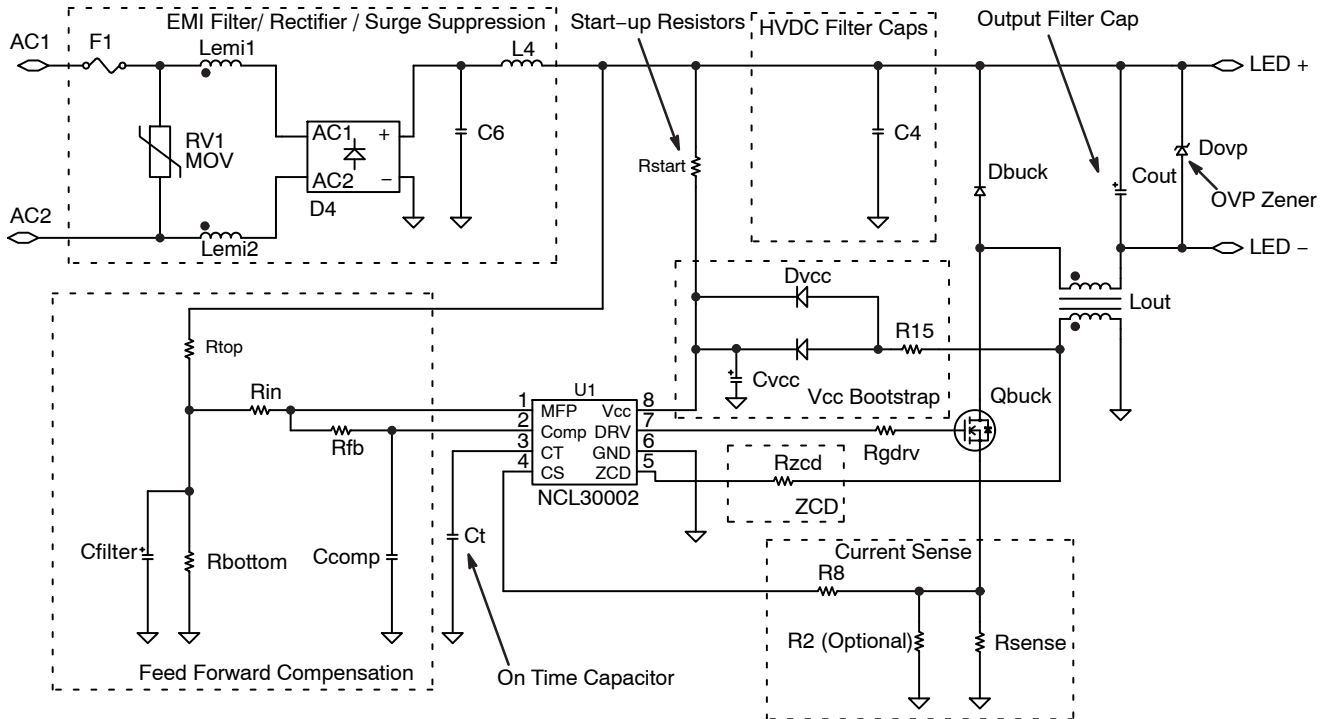

Figure 2. Simplified PFC Buck Application

Overview

Figure 2 illustrates the basic NCL30002 architecture for a non-isolated low power high power factor LED driver. One of the notable features of this architecture is the open loop control. Notice that there is no direct measurement of the LED current. Tight peak current control coupled with line feed-forward compensation to vary the on-time allows for accurate LED drive current. Fortunately in the vast majority of LED bulb and luminaire applications, the LED forward voltage range is well bounded and the line voltage may be limited to one operating range. This is a huge advantage which makes the simplicity of open loop control possible.

Buck switching on the low side eliminates a floating gate drive but references the LED to the HV rail. Buck converters only produce output when the input voltage exceeds the load voltage. Consequently, the input current goes to zero near the zero crossing of the line. The exact phase angle of this event depends on the LED string voltage and the line voltage. Unlike the boost PFC, the buck PFC has increased distortion near the zero crossing. However even with cross over distortion, high power factor and acceptable harmonics can be achieved.

NCL30002

Table 2. MAXIMUM RATINGS

Rating	Symbol	Value	Unit
MFP Voltage	V_{MFP}	-0.3 to 10	V
MFP Current	I_{MFP}	± 10	mA
COMP Voltage	$V_{Control}$	-0.3 to 6.5	V
COMP Current	$I_{Control}$	-2 to 10	mA
Ct Voltage	V_{Ct}	-0.3 to 6	V
Ct Current	I_{Ct}	± 10	mA
CS Voltage	V_{CS}	-0.3 to 6	V
CS Current	I_{CS}	± 10	mA
ZCD Voltage	V_{ZCD}	-0.3 to 10	V
ZCD Current	I_{ZCD}	± 10	mA
DRV Voltage	V_{DRV}	-0.3 to V_{CC}	V
DRV Sink Current	$I_{DRV(sink)}$	800	mA
DRV Source Current	$I_{DRV(source)}$	500	mA
Supply Voltage	V_{CC}	-0.3 to 20	V
Supply Current	I_{CC}	± 20	mA
Power Dissipation ($T_A = 70^\circ\text{C}$, 2.0 Oz Cu, 55 mm ² Printed Circuit Copper Clad)	P_D	450	mW
Thermal Resistance Junction-to-Ambient (2.0 Oz Cu, 55 mm ² Printed Circuit Copper Clad)	$R_{\theta JA}$	178	$^\circ\text{C}/\text{W}$
Junction-to-Air, Low conductivity PCB (Note 3)	$R_{\theta JA}$	168	
Junction-to-Air, High conductivity PCB (Note 4)	$R_{\theta JA}$	127	
Operating Junction Temperature Range	T_J	-40 to 125	$^\circ\text{C}$
Maximum Junction Temperature	$T_{J(MAX)}$	150	$^\circ\text{C}$
Storage Temperature Range	T_{STG}	-65 to 150	$^\circ\text{C}$
Lead Temperature (Soldering, 10 s)	T_L	300	$^\circ\text{C}$

Stresses exceeding Maximum Ratings may damage the device. Maximum Ratings are stress ratings only. Functional operation above the Recommended Operating Conditions is not implied. Extended exposure to stresses above the Recommended Operating Conditions may affect device reliability.

- This device series contains ESD protection and exceeds the following tests:
Pins 1– 8: Human Body Model 2000 V per JEDEC Standard JESD22–A114E.
Machine Model Method 200 V per JEDEC Standard JESD22–A115–A.
- This device contains Latch-Up protection and exceeds ± 100 mA per JEDEC Standard JESD78.
- As mounted on a 40x40x1.5 mm FR4 substrate with a single layer of 80 mm² of 2 oz copper traces and heat spreading area. As specified for a JEDEC 51 low conductivity test PCB. Test conditions were under natural convection or zero air flow.
- As mounted on a 40 x 40 x 1.5 mm FR4 substrate with a single layer of 650 mm² of 2 oz copper traces and heat spreading area. As specified for a JEDEC 51 high conductivity test PCB. Test conditions were under natural convection or zero air flow.

NCL30002

Table 3. ELECTRICAL CHARACTERISTICS

$V_{MFP} = 2.4\text{ V}$, $V_{Control} = 4\text{ V}$, $C_t = 1\text{ nF}$, $V_{CS} = 0\text{ V}$, $V_{ZCD} = 0\text{ V}$, $C_{DRV} = 1\text{ nF}$, $V_{CC} = 12\text{ V}$, unless otherwise specified
(For typical values, $T_J = 25^\circ\text{C}$. For min/max values, $T_J = -40^\circ\text{C}$ to 125°C , unless otherwise specified)

Characteristic	Test Conditions	Symbol	Min	Typ	Max	Unit
STARTUP AND SUPPLY CIRCUITS						
Startup Voltage Threshold	V_{CC} Increasing	$V_{CC(on)}$	11	12	12.5	V
Minimum Operating Voltage	V_{CC} Decreasing	$V_{CC(off)}$	8.8	9.5	10.2	V
Supply Voltage Hysteresis		H_{UVLO}	2.2	2.5	2.8	V
Startup Current Consumption	$0\text{ V} < V_{CC} < V_{CC(on)} - 200\text{ mV}$	$I_{cc(startup)}$	-	24	35	μA
No Load Switching Current Consumption	$C_{DRV} = \text{open}$, 70 kHz Switching, $V_{CS} = 2\text{ V}$	I_{cc1}	-	1.4	1.7	mA
Switching Current Consumption	70 kHz Switching, $V_{CS} = 2\text{ V}$	I_{cc2}	-	2.1	2.6	mA
Fault Condition Current Consumption	No Switching, $V_{MFP} = 0\text{ V}$	$I_{cc(fault)}$	-	0.75	0.95	mA
OVERVOLTAGE AND UNDERVOLTAGE PROTECTION						
Overvoltage Detect Threshold	$V_{MFP} = \text{Increasing}$	V_{OVP}	2.5	2.67	2.85	V
Overvoltage Hysteresis		$V_{OVP(HYS)}$	20	60	100	mV
Overvoltage Detect Threshold Propagation Delay	$V_{MFP} = 1\text{ V}$ to 3 V step, $V_{MFP} = V_{OVP}$ to $V_{DRV} = 10\%$	t_{OVP}	-	500	800	ns
Undervoltage Detect Threshold	$V_{MFP} = \text{Decreasing}$	V_{UVP}	0.25	0.31	0.4	V
Undervoltage Detect Threshold Propagation Delay	$V_{MFP} = 2\text{ V}$ to 0 V step, $V_{MFP} = V_{UVP}$ to $V_{DRV} = 10\%$	t_{UVP}	80	200	320	ns
ERROR AMPLIFIER						
Voltage Reference	$T_J = 25^\circ\text{C}$ $T_J = -40^\circ\text{C}$ to 125°C	V_{REF}	2.397 2.359	2.510 2.510	2.623 2.661	V
Voltage Reference Line Regulation	$V_{CC(on)} + 200\text{ mV} < V_{CC} < 20\text{ V}$	$V_{REF(line)}$	-10	-	10	mV
Error Amplifier Current Capability	$V_{MFP} = V_{REF} + 0.11\text{ V}$ $V_{MFP} = 1.08 * V_{REF}$ $V_{MFP} = 0.5\text{ V}$	$I_{EA(sink)}$ $I_{EA(sink)OVP}$ $I_{EA(source)}$	6 10 -110	10 20 -210	20 30 -250	μA
Transconductance	$V_{MFP} = V_{REF} \pm 100\text{ mV}$ $T_J = 25^\circ\text{C}$ $T_J = -40^\circ\text{C}$ to 125°C	gm	90 70	110 110	120 135	μS
Feedback Pin Internal Pull-Down Resistor	$V_{MFP} = V_{UVP}$ to V_{REF}	R_{MFP}	2	4.6	10	$\text{M}\Omega$
Feedback Bias Current	$V_{MFP} = 2.5\text{ V}$	I_{MFP}	0.25	0.54	1.25	μA
Control Bias Current	$V_{MFP} = 0\text{ V}$	$I_{Control}$	-1	-	1	μA
Maximum Control Voltage	$I_{Control(pullup)} = 10\ \mu\text{A}$, $V_{MFP} = V_{REF}$	V_{EAH}	5	5.5	6	V
Minimum Control Voltage to Generate Drive Pulses	$V_{Control} = \text{Decreasing until}$ V_{DRV} is low, $V_{Ct} = 0\text{ V}$	$C_{t(offset)}$	0.37	0.65	0.88	V
Control Voltage Range	$V_{EAH} - C_{t(offset)}$	$V_{EA(DIFF)}$	4.5	4.9	5.3	V

NCL30002

Table 3. ELECTRICAL CHARACTERISTICS (Continued)

$V_{MFP} = 2.4\text{ V}$, $V_{Control} = 4\text{ V}$, $C_t = 1\text{ nF}$, $V_{CS} = 0\text{ V}$, $V_{ZCD} = 0\text{ V}$, $C_{DRV} = 1\text{ nF}$, $V_{CC} = 12\text{ V}$, unless otherwise specified
(For typical values, $T_J = 25^\circ\text{C}$. For min/max values, $T_J = -40^\circ\text{C}$ to 125°C , unless otherwise specified)

Characteristic	Test Conditions	Symbol	Min	Typ	Max	Unit
----------------	-----------------	--------	-----	-----	-----	------

RAMP CONTROL

Ct Peak Voltage	$V_{COMP} = \text{open}$	$V_{Ct(MAX)}$	4.535	4.93	5.25	V
On Time Capacitor Charge Current	$V_{COMP} = \text{open}$ $V_{Ct} = 0\text{ V to }V_{Ct(MAX)}$	I_{charge}	240	270	292	μA
Ct Capacitor Discharge Duration	$V_{COMP} = \text{open}$ $V_{Ct} = V_{Ct(MAX)} - 100\text{ mV to }500\text{ mV}$	$t_{Ct(discharge)}$	-	50	150	ns
PWM Propagation Delay	$dV/dt = 30\text{ V}/\mu\text{s}$ $V_{Ct} = V_{Control} - C_t t_{(offset)}$ to $V_{DRV} = 10\%$	t_{PWM}	-	130	220	ns

ZERO CURRENT DETECTION

ZCD Arming Threshold	$V_{ZCD} = \text{Increasing}$	$V_{ZCD(ARM)}$	1.25	1.4	1.55	V
ZCD Triggering Threshold	$V_{ZCD} = \text{Decreasing}$	$V_{ZCD(TRIG)}$	0.6	0.7	0.83	V
ZCD Hysteresis		$V_{ZCD(HYS)}$	500	700	900	mV
ZCD Bias Current	$V_{ZCD} = 5\text{ V}$	I_{ZCD}	-2	-	+2	μA
Positive Clamp Voltage	$I_{ZCD} = 3\text{ mA}$	$V_{CL(POS)}$	9.8	10	12	V
Negative Clamp Voltage	$I_{ZCD} = -2\text{ mA}$	$V_{CL(NEG)}$	-0.9	-0.7	-0.5	V
ZCD Propagation Delay	$V_{ZCD} = 2\text{ V to }0\text{ V ramp}$, $dV/dt = 20\text{ V}/\mu\text{s}$ $V_{ZCD} = V_{ZCD(TRIG)}$ to $V_{DRV} = 90\%$	t_{ZCD}	-	100	170	ns
Minimum ZCD Pulse Width		t_{SYNC}	-	70	-	ns
Maximum Off Time in Absence of ZCD Transition	Falling $V_{DRV} = 10\%$ to Rising $V_{DRV} = 90\%$	t_{start}	75	165	300	μs

DRIVE

Drive Resistance	$I_{source} = 100\text{ mA}$ $I_{sink} = 100\text{ mA}$	R_{OH} R_{OL}	- -	12 6	20 13	Ω
Rise Time	10% to 90%	t_{rise}	-	35	80	ns
Fall Time	90% to 10%	t_{fall}	-	25	70	ns
Drive Low Voltage	$V_{CC} = V_{CC(on)} - 200\text{ mV}$, $I_{sink} = 10\text{ mA}$	$V_{out(start)}$	-	-	0.2	V

CURRENT SENSE

Current Sense Voltage Threshold	$T_J = 25^\circ\text{C}$ $T_J = -40^\circ\text{C to }125^\circ\text{C}$	V_{ILIM}	0.475 0.470	0.485 0.485	0.495 0.500	V
Leading Edge Blanking Duration	$V_{CS} = 2\text{ V}$, $V_{DRV} = 90\%$ to 10%	t_{LEB}	100	195	350	ns
Overcurrent Detection Propagation Delay	$dV/dt = 10\text{ V}/\mu\text{s}$ $V_{CS} = V_{ILIM}$ to $V_{DRV} = 10\%$	t_{CS}	40	100	170	ns
Current Sense Bias Current	$V_{CS} = 2\text{ V}$	I_{CS}	-1	-	1	μA

TYPICAL CHARACTERISTICS

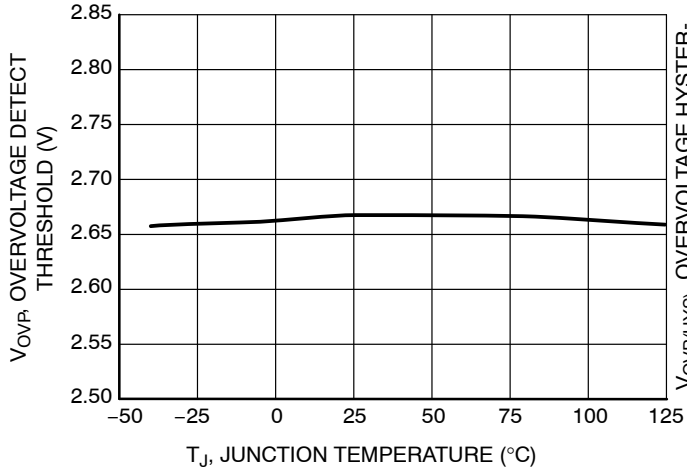

Figure 3. Overvoltage Detect Threshold vs. Junction Temperature

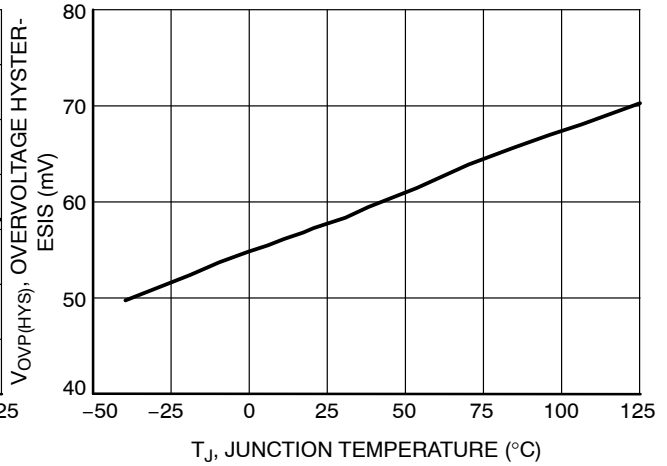

Figure 4. Overvoltage Hysteresis vs. Junction Temperature

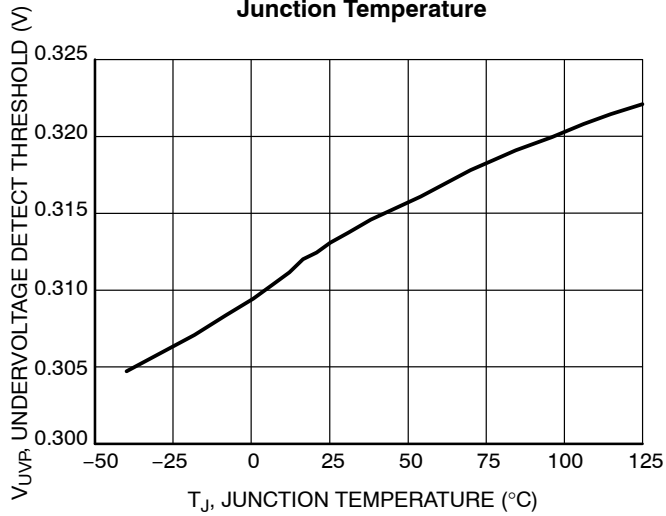

Figure 5. Undervoltage Detect Threshold vs. Junction Temperature

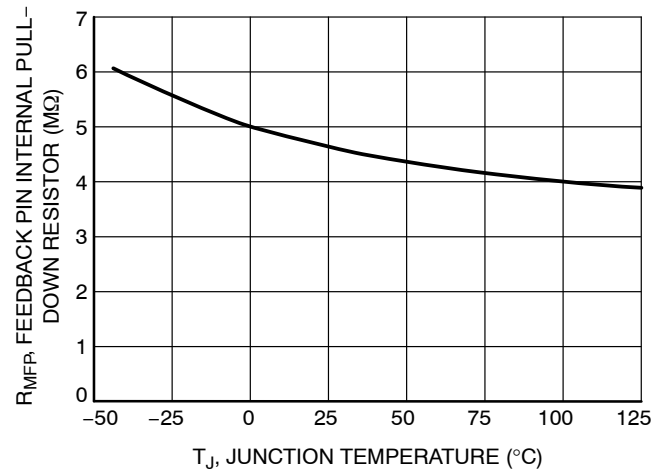

Figure 6. MFP Pin Internal Pull-Down Resistor vs. Junction Temperature

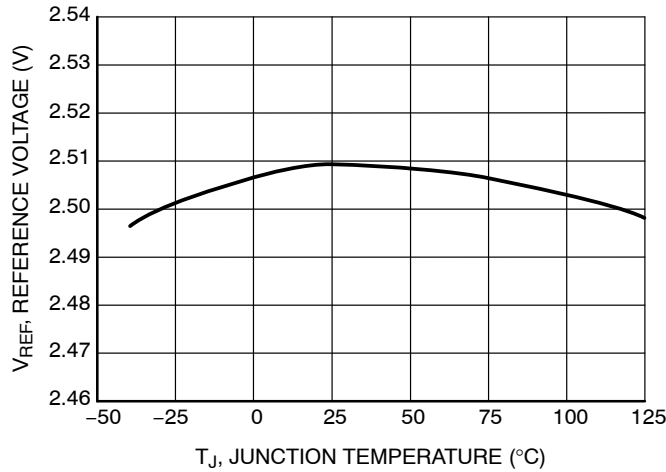

Figure 7. Reference Voltage vs. Junction Temperature

TYPICAL CHARACTERISTICS

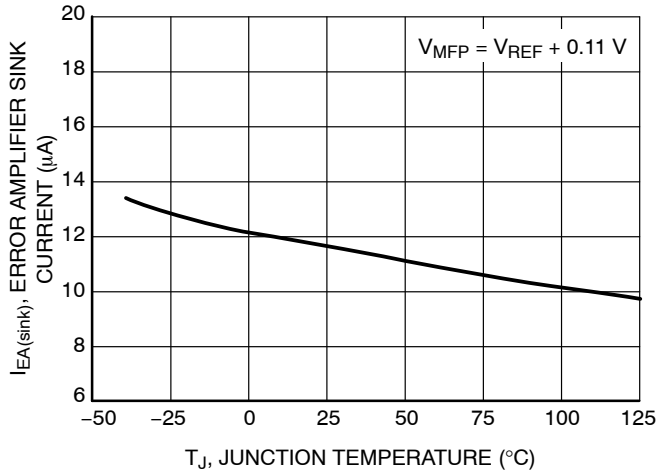

Figure 8. Error Amplifier Sink Current vs. Junction Temperature

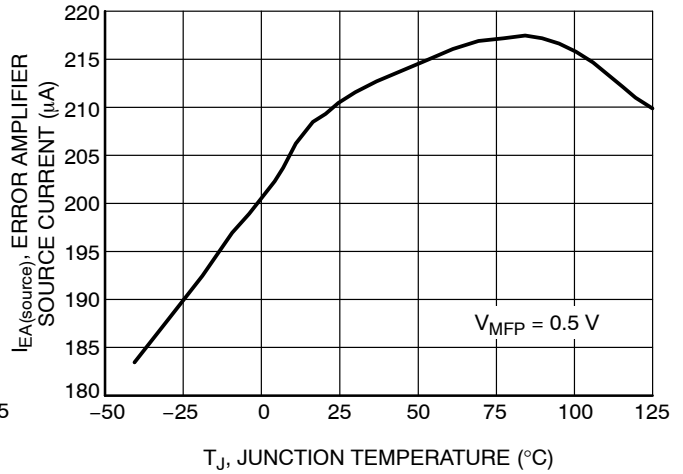

Figure 9. Error Amplifier Source Current vs. Junction Temperature

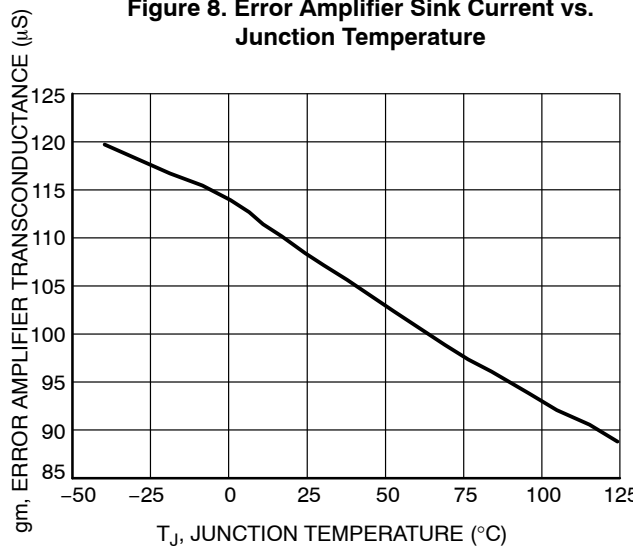

Figure 10. Error Amplifier Transconductance vs. Junction Temperature

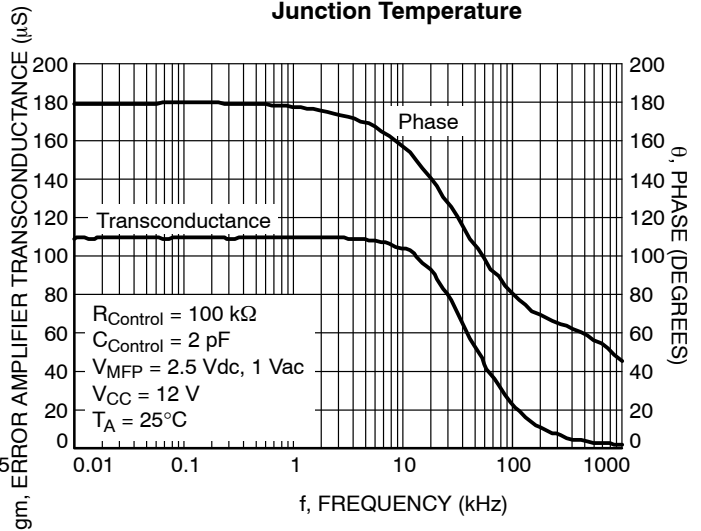

Figure 11. Error Amplifier Transconductance and Phase vs. Frequency

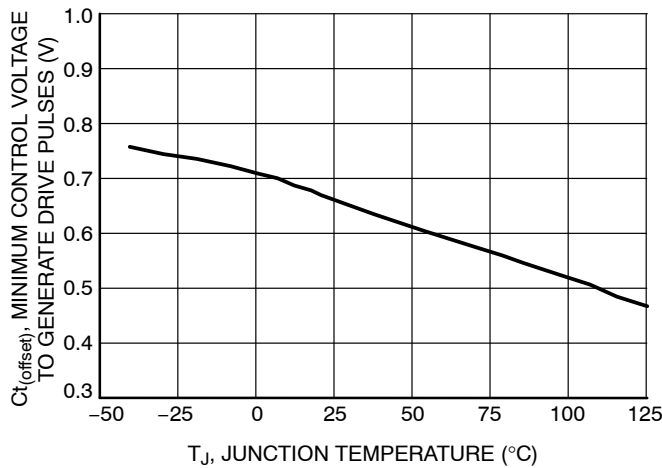

Figure 12. Minimum Control Voltage to Generate Drive Pulses vs. Junction Temperature

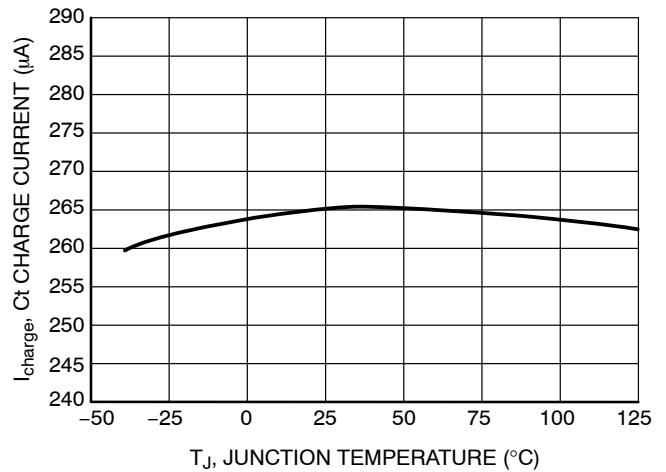

Figure 13. On Time Capacitor Charge Current vs. Junction Temperature

TYPICAL CHARACTERISTICS

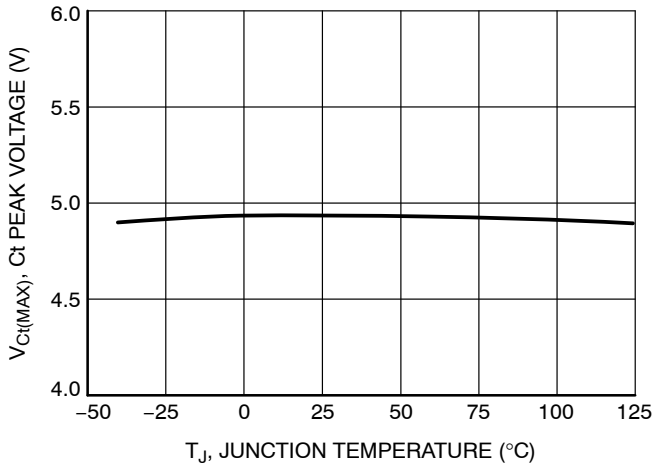

Figure 14. Ct Peak Voltage vs. Junction Temperature

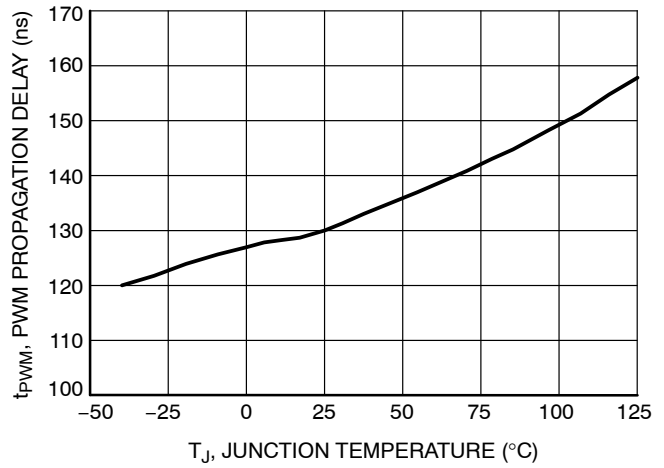

Figure 15. PWM Propagation Delay vs. Junction Temperature

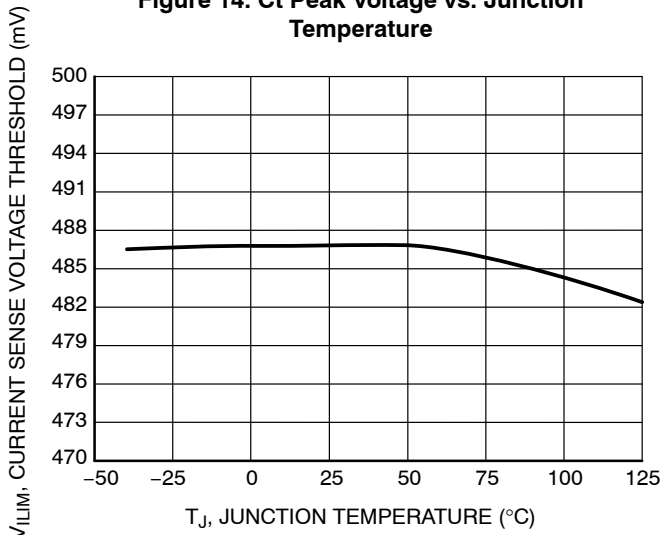

Figure 16. Current Sense Voltage Threshold vs. Junction Temperature

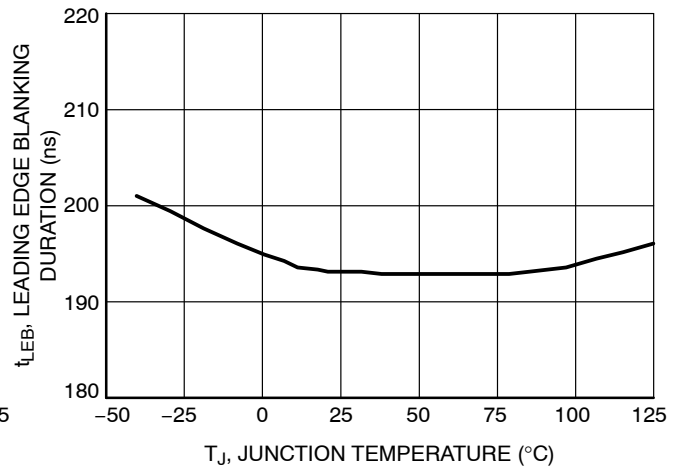

Figure 17. Leading Edge Blanking Duration vs. Junction Temperature

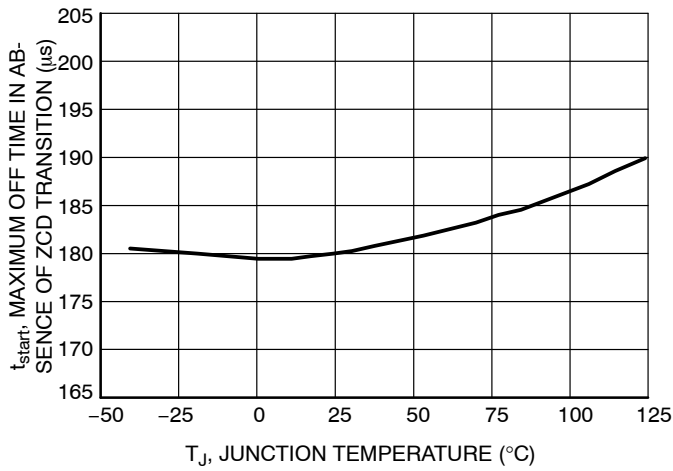

Figure 18. Maximum Off Time in Absence of ZCD Transition vs. Junction Temperature

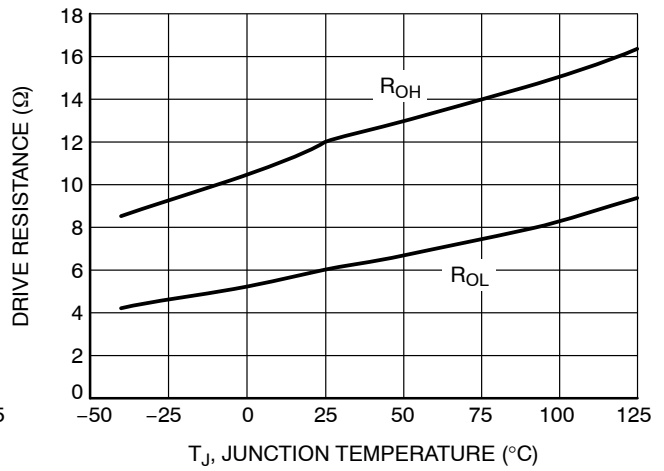

Figure 19. Drive Resistance vs. Junction Temperature

TYPICAL CHARACTERISTICS

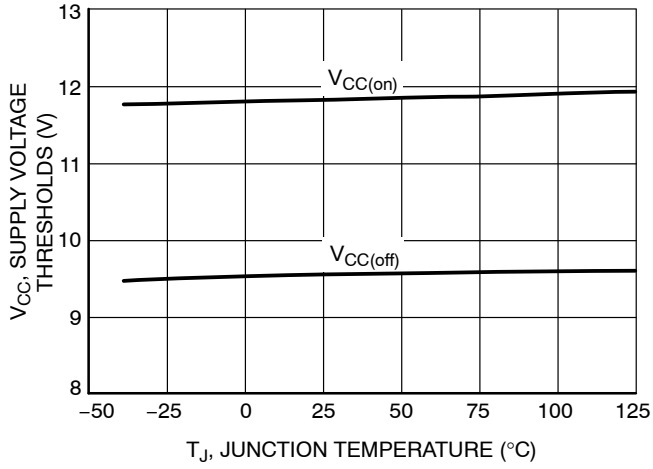

Figure 20. Supply Voltage Thresholds vs. Junction Temperature

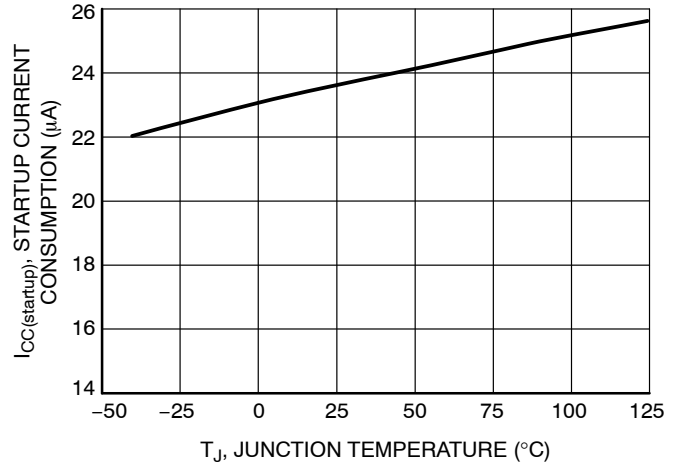

Figure 21. Startup Current Consumption vs. Junction Temperature

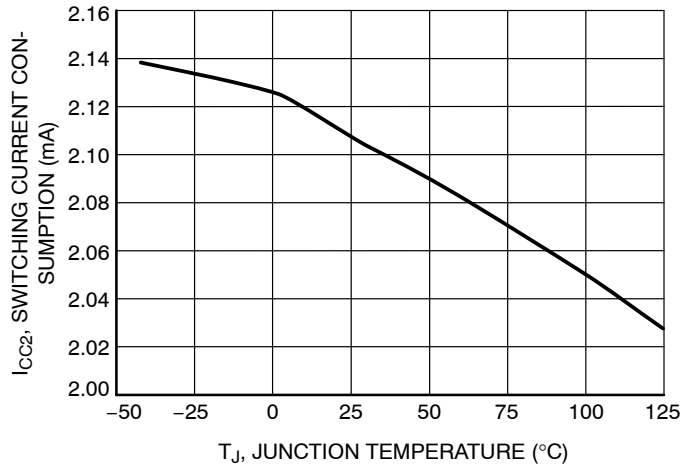

Figure 22. Switching Current Consumption vs. Junction Temperature

THEORY OF OPERATION

High power factor, high efficiency, and small size are key parameters for LED drivers in the incandescent replacement market. The NCL30002 has all the features required to accomplish that in a compact SOIC-8 package. Power factor is broadly defined as:

$$PF = \frac{P_{in}(avg)}{V_{in}(rms) \times I_{in}(rms)}$$

This differs from the classical definition where there is a phase angle difference between the input voltage and current. However, the underlying concept of optimizing power delivery by minimizing line current is the same. Ideally, current would be directly proportional to the voltage which is the case when the load is a resistor. Offline power converters are active devices which are not purely resistive, capacitive, or inductive often drawing distorted current waveforms from the power lines. This distortion reduces power factor by increasing input RMS current. Preregulators using boost converters are the most common method to correcting the distortion and making the offline power supply appear to be a resistor as far as the power line is concerned. Their performance is excellent achieving power factor greater than 0.99. Regrettably, this two stage approach negatively impacts efficiency and board area. Fortunately, power factors greater than 0.9 are acceptable in the general lighting market and in some applications like US Energystar™ Integral LED bulbs, the minimum acceptable

power factor is 0.7. So a certain amount of distortion can be accepted while maintaining high power factor. This buck topology meets the requirements for PF greater than 0.9 and regulate LED current in a single power stage. Unlike the boost converter, the NCL30002 buck controller operates in several different modes over the line cycle.

Buck Modes

1. “Zero” Input Current ($I_{in}=0$) - Buck converters cannot deliver power when V_{in} is less than V_{out} . The “dead time” where no current flows around the zero crossing is dependent on the line voltage and the load voltage.
2. Constant On-Time ($T_{on} = \text{constant}$) - This is the same as the boost converter. Constant T_{on} forces the peak current to be proportional to the input voltage which is key to improved PF.
3. Constant Peak Current ($I_{peak} = \text{constant}$) – The NCL30002 limits the peak inductor and thus the LED current. In this region, the unique nature of the CrM buck means that the average output current is equal to half the peak current. Also the off time is fixed in this mode since the peak current and the output voltage are virtually constant.

In the example below (Figure 23) in spite of the distortion, the power factor is 0.97. The corresponding pre-filtered output current is shown in Figure 24.

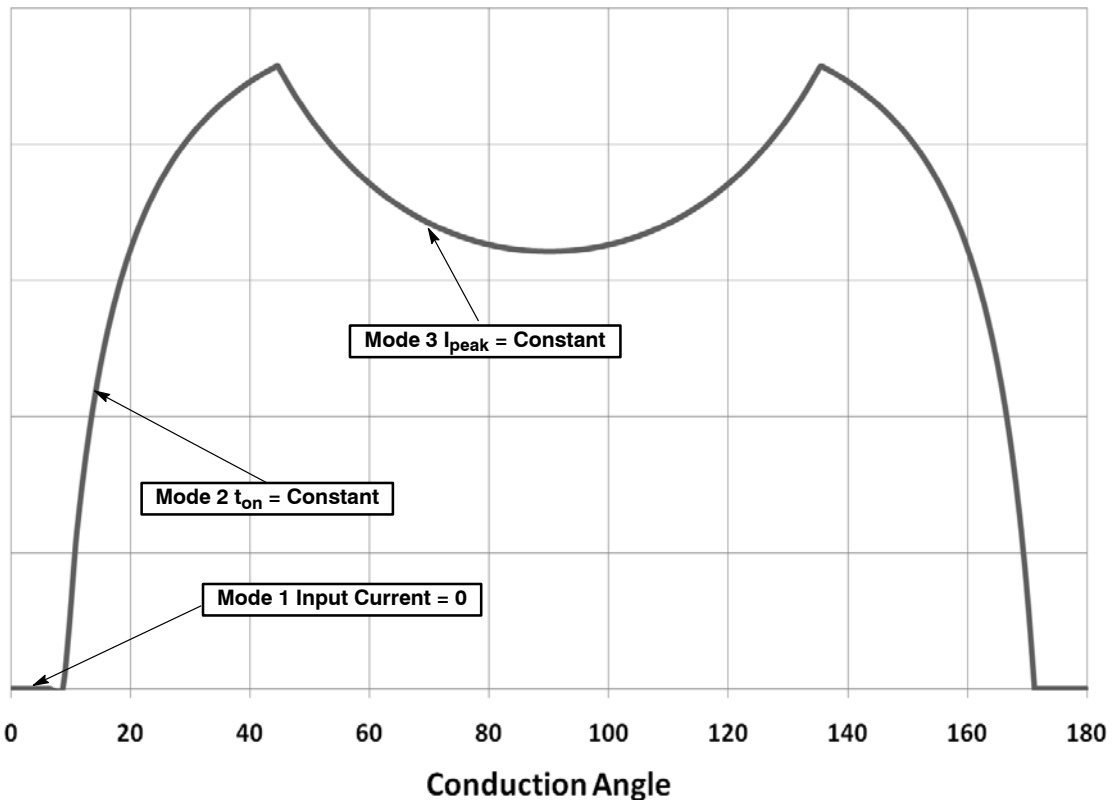

Figure 23. Theoretical Average Input Current over one half line cycle (conduction angle)

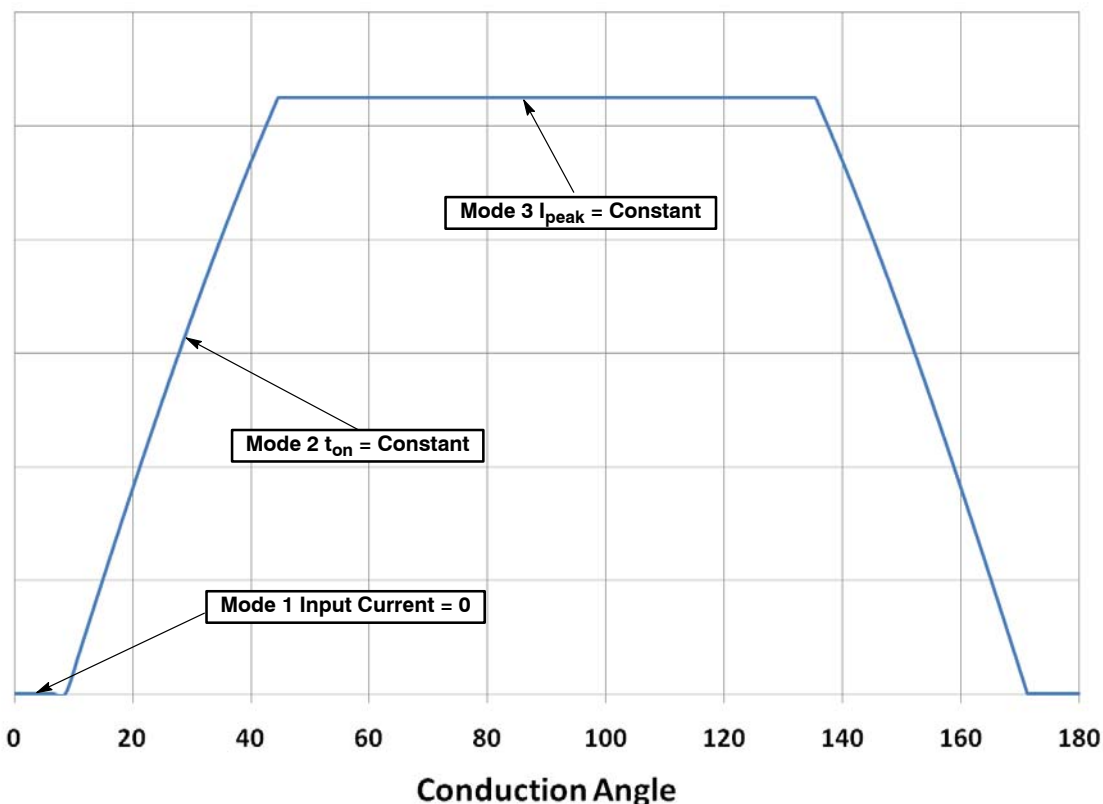

Figure 24. Theoretical Average Output Current over one half line cycle (conduction angle)

An output capacitor filters the output current in the LED string. The dynamic LED resistance, line frequency, and the size of the filter capacitance determine the exact LED ripple.

The NCL30002 operates as a CrM controller. The controller draws very low currents while the V_{CC} filter capacitor charges to the start-up threshold. Since CrM operation is not clocked at a fixed frequency and depends on the state of the power circuit to initiate a new switching cycle, a kick start timer turns on the gate driver to start a new cycle. The kick start timer will do this anytime the driver is off for more than about 180 μsec as long as none of the protection circuits are disabling the gate driver output.

The NCL30002 (refer to the block diagram – Figure 1) is composed of 4 key functional blocks along with protection circuitry to ensure reliable operation of the controller.

- On-Time Control
- Zero Current Detection Control
- MOSFET Gate Driver
- Startup and V_{CC} Management

On Time Control

The on-time control circuitry (Figure 25) consists of a precision current source which charges up an external capacitor (C_t) in a linear ramp. The voltage on C_t (after removing an internal offset) is compared to an external control voltage and the output of the comparator is used to turn off the output driver thus terminating the switching cycle. A signal from the driver is fed back to the on-time control block to discharge the C_t capacitor thus preparing the circuit for the start of the next switching cycle.

The state of V_{control} is determined by the external regulation loop. The range of on-time is determined by the charging slope of the C_t capacitor and is clamped at 4.93 V nominal. The C_t capacitor is sized to ensure that the required on-time is reached at maximum output power and the minimum input line voltage condition.

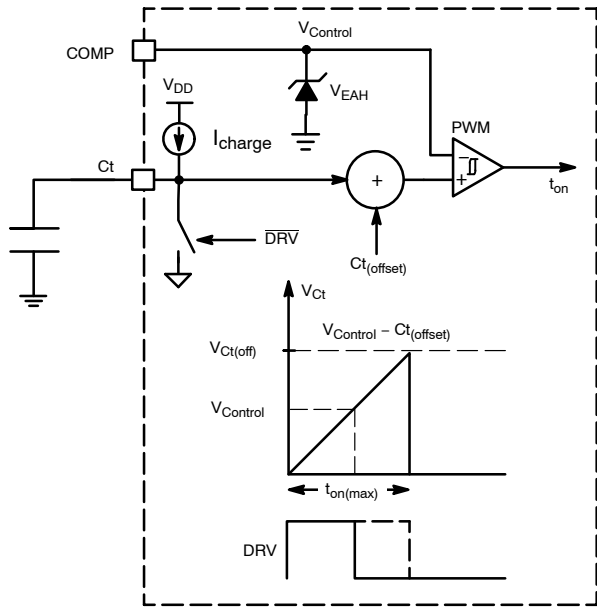

Figure 25. On Time Control

Off Time Sequence

The off time is determined by the peak inductor current, the inductance and the output voltage. In mode 2, the off time is variable because the peak inductor current is not fixed. However in mode 3, the off time is constant since the peak current and the output voltage are both fixed. The auxiliary winding used to provide bias to the NCL30002 is also used to detect when the current has dropped to zero. This is illustrated in Figure 26.

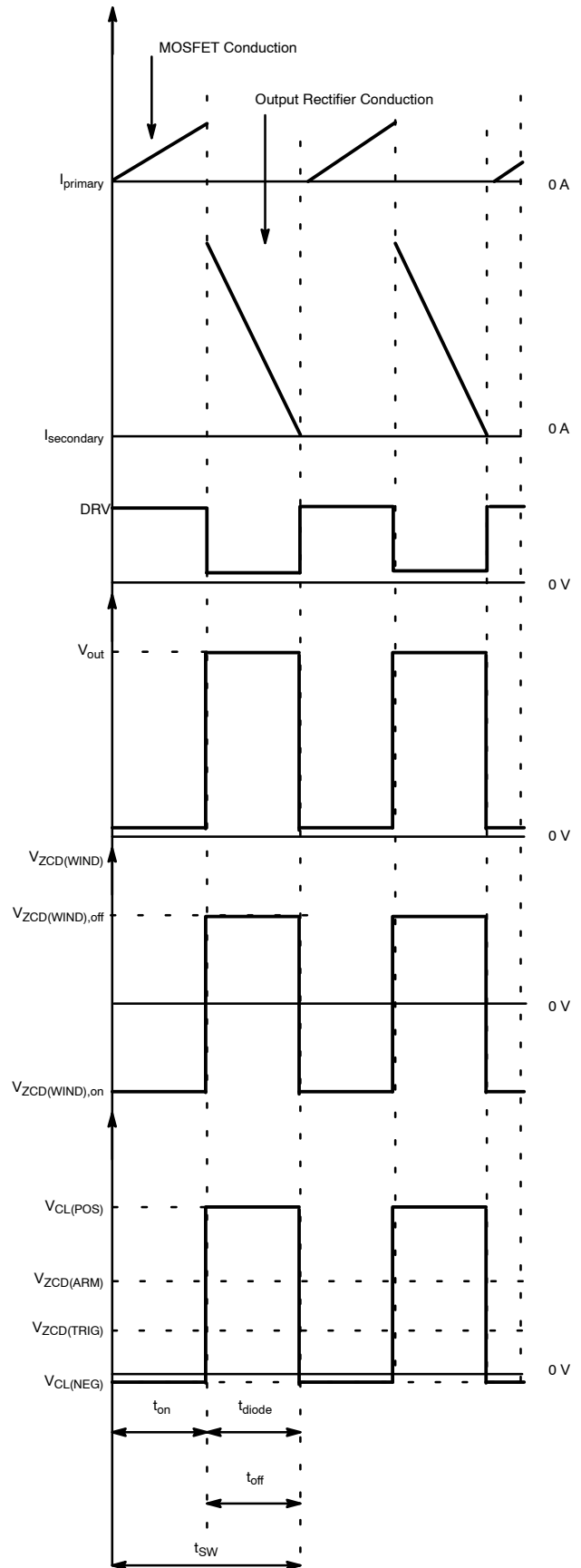

Figure 26. Ideal CrM Waveforms with ZCD Winding

ZCD Detection Block

A dedicated circuit block is necessary to implement the zero current detection. The NCL30002 provides a separate input pin to signal the controller to turn the power switch back on just after inductor current reaches zero. When the output winding current reaches zero the winding voltage will reverse. Since all windings of the inductor reflect the same voltage characteristic this voltage reversal appears on the bias winding. Coupling the winding voltage to the ZCD input of the NCL30002 allows the controller to start the next switching cycle at the precise time. To avoid false triggering,

the ZCD input has a dual comparator input structure to arm the latch when the ZCD detect voltage rises above 1.4 V (nominal) thus setting the latch. When the voltage on ZCD falls below 0.7 V (nominal) a zero current event is detected and a signal is asserted which initiates the next switching cycle. This is illustrated in Figure 27. The input of the ZCD has an internal circuit which clamps the positive and negative voltage excursions on this pin. The current into or out of the ZCD pin must be limited to ±10 mA with an external resistor.

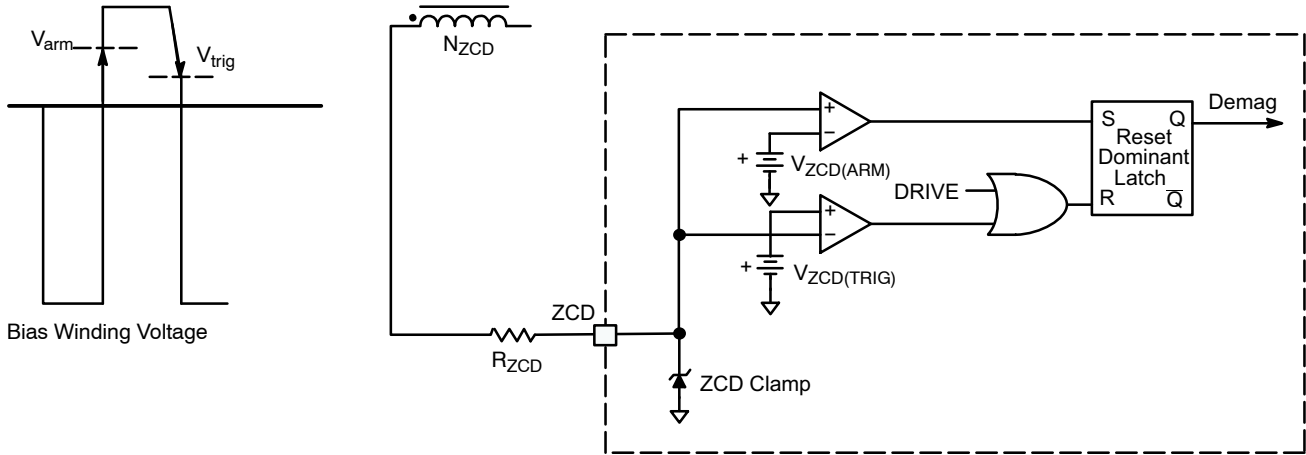

Figure 27. ZCD Operation

At startup, there is no energy in the ZCD winding and no voltage signal to activate the ZCD comparators. To enable the controller to start under these conditions, an internal watchdog timer is provided which initiates a switching cycle in the event that the output drive has been off for more than 180 μs (nominal).

The timer is deactivated only under an OVP or UVP fault condition which will be discussed in the next section.

CS

The dedicated CS pin of the NCL30002 senses the current through the MOSFET switch and the output inductor. If the voltage of the CS pin exceeds V_ILIM, the internal comparator will detect the event and turn off the MOSFET. The peak switch current is calculated using Equation 1:

$$I_{SW(peak)} = \frac{V_{ILIM}}{R_{sense}} \quad (\text{eq. 1})$$

To avoid false detection, the NCL30002 incorporates leading edge blanking circuit (LEB) which masks the CS signal for a nominal time of 190 ns. If required, an optional RC filter can be added between R_sense and CS to provide additional filtering. This is illustrated below.

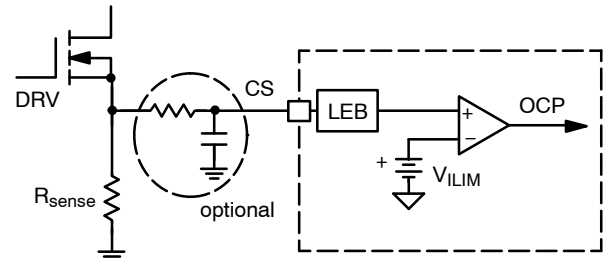

Figure 28. CS Circuitry with Optional External RC Filter

MFP Input

The multi-function pin connects to the inverting terminal of the transconductance amplifier, the undervoltage and overvoltage protection comparators. This allows this pin to perform several functions. To place the device in standby, the MFP pin should be pulled below the V_UVP threshold. This is illustrated in Figure 29. Additionally, raising the MFP pin above V_OVP will also suspend switching activity but not place the controller in the standby mode. This can be used to implement overvoltage monitoring on the bias winding and add an additional layer of fault protection.

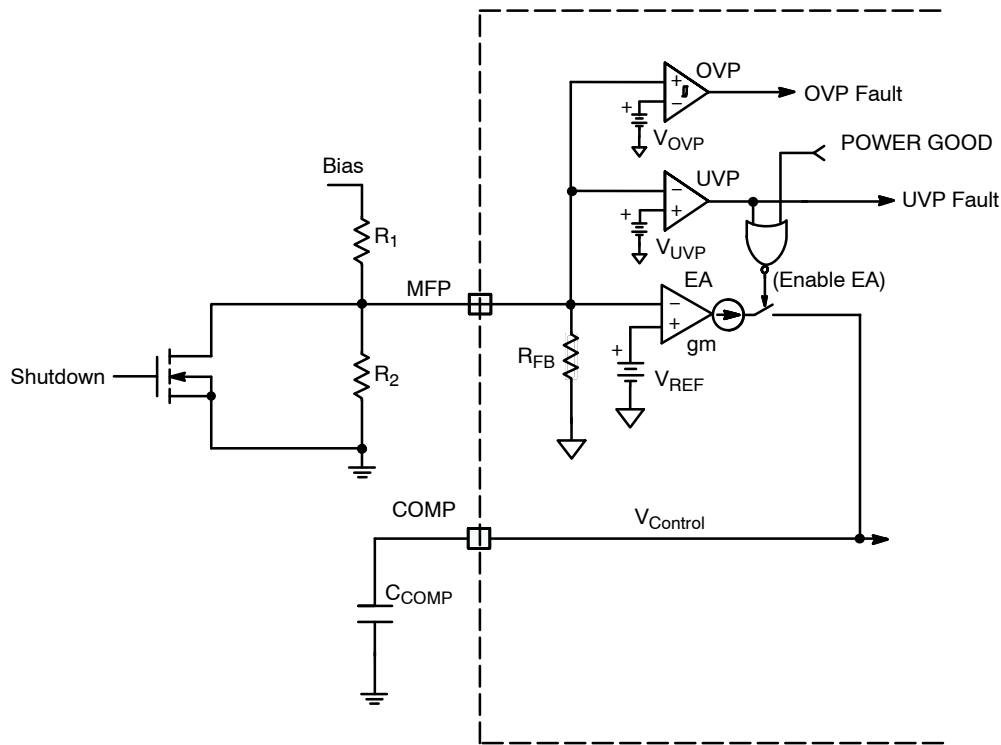

Figure 29. Multi-Function Pin Operation

The positive input of the transconductance amplifier is connected to a 2.51 V (nominal) reference. A filtered line feed-forward signal (see Figure 2) is connected to the negative input of the error amplifier and used to control the on-time of controller.

V_{CC} Management

The NCL30002 incorporates a supervisory circuitry to manage the startup and shutdown of the circuit. By managing the startup and keeping the initial startup current at less than 35 μ A, a startup resistor connected between the rectified ac line and V_{CC} charges the V_{CC} capacitor to V_{CC(on)}. Turn on of the device occurs when the startup voltage has exceeded 12 V (nominal) when the internal reference and switching logic are enabled. A UVLO comparator with a hysteresis of 2.5 V nominal gives ample time for the device to start switching and allow the bias from the auxiliary winding to supply V_{CC}.

Design Tool

The NCL30002 implements a unique control method to achieve high power and superior current regulation even though the average current is not directly sensed. There are a number of design tradeoffs that can be made between peak switch current, inductor size, and desired power factor that can impact the current regulation accuracy, efficiency, and physical size. These tradeoffs can be made by adjusting the amount of line feed forward applied, selecting the amount of time where the controller is operating in mode 2 and 3, as well as factoring in the LED forward voltage range. To simplify the component selection process and allow the designer to interactively make these tradeoffs, ON Semiconductor has developed an EXCEL™ based Design Guide which allows step-by-step analysis. This tool is available at onsemi.com along with a supporting application note that illustrates a complete design and provides typical application performance.

NCL30002

PACKAGE DIMENSIONS

SOIC-8 NB CASE 751-07 ISSUE AK

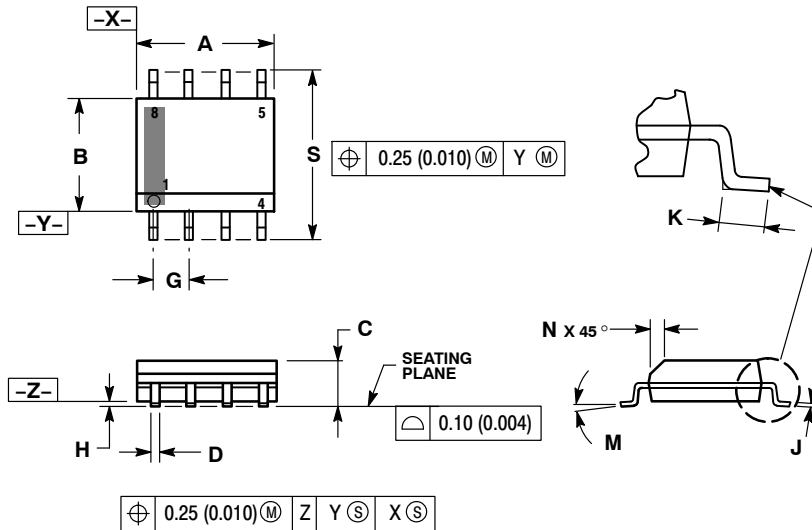

- NOTES:
1. DIMENSIONING AND TOLERANCING PER ANSI Y14.5M, 1982.
 2. CONTROLLING DIMENSION: MILLIMETER.
 3. DIMENSION A AND B DO NOT INCLUDE MOLD PROTRUSION.
 4. MAXIMUM MOLD PROTRUSION 0.15 (0.006) PER SIDE.
 5. DIMENSION D DOES NOT INCLUDE DAMBAR PROTRUSION. ALLOWABLE DAMBAR PROTRUSION SHALL BE 0.127 (0.005) TOTAL IN EXCESS OF THE D DIMENSION AT MAXIMUM MATERIAL CONDITION.
 6. 751-01 THRU 751-06 ARE OBSOLETE. NEW STANDARD IS 751-07.

DIM	MILLIMETERS		INCHES	
	MIN	MAX	MIN	MAX
A	4.80	5.00	0.189	0.197
B	3.80	4.00	0.150	0.157
C	1.35	1.75	0.053	0.069
D	0.33	0.51	0.013	0.020
G	1.27 BSC		0.050 BSC	
H	0.10	0.25	0.004	0.010
J	0.19	0.25	0.007	0.010
K	0.40	1.27	0.016	0.050
M	0°	8°	0°	8°
N	0.25	0.50	0.010	0.020
S	5.80	6.20	0.228	0.244

SOLDERING FOOTPRINT*

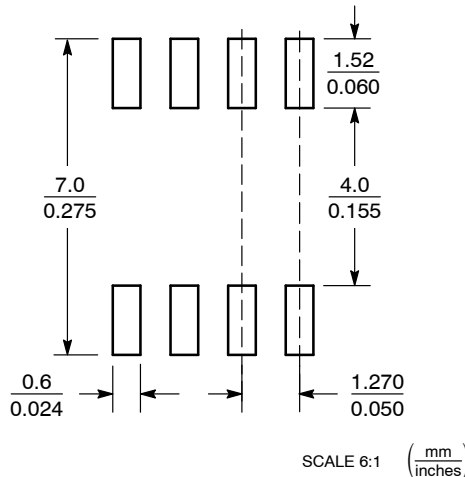

*For additional information on our Pb-Free strategy and soldering details, please download the ON Semiconductor Soldering and Mounting Techniques Reference Manual, SOLDERRM/D.

ON Semiconductor and are registered trademarks of Semiconductor Components Industries, LLC (SCILLC). SCILLC reserves the right to make changes without further notice to any products herein. SCILLC makes no warranty, representation or guarantee regarding the suitability of its products for any particular purpose, nor does SCILLC assume any liability arising out of the application or use of any product or circuit, and specifically disclaims any and all liability, including without limitation special, consequential or incidental damages. "Typical" parameters which may be provided in SCILLC data sheets and/or specifications can and do vary in different applications and actual performance may vary over time. All operating parameters, including "Typicals" must be validated for each customer application by customer's technical experts. SCILLC does not convey any license under its patent rights nor the rights of others. SCILLC products are not designed, intended, or authorized for use as components in systems intended for surgical implant into the body, or other applications intended to support or sustain life, or for any other application in which the failure of the SCILLC product could create a situation where personal injury or death may occur. Should Buyer purchase or use SCILLC products for any such unintended or unauthorized application, Buyer shall indemnify and hold SCILLC and its officers, employees, subsidiaries, affiliates, and distributors harmless against all claims, costs, damages, and expenses, and reasonable attorney fees arising out of, directly or indirectly, any claim of personal injury or death associated with such unintended or unauthorized use, even if such claim alleges that SCILLC was negligent regarding the design or manufacture of the part. SCILLC is an Equal Opportunity/Affirmative Action Employer. This literature is subject to all applicable copyright laws and is not for resale in any manner.

PUBLICATION ORDERING INFORMATION

LITERATURE FULFILLMENT:
Literature Distribution Center for ON Semiconductor
P.O. Box 5163, Denver, Colorado 80217 USA
Phone: 303-675-2175 or 800-344-3860 Toll Free USA/Canada
Fax: 303-675-2176 or 800-344-3867 Toll Free USA/Canada
Email: orderlit@onsemi.com

N. American Technical Support: 800-282-9855 Toll Free
USA/Canada
Europe, Middle East and Africa Technical Support:
Phone: 421 33 790 2910
Japan Customer Focus Center
Phone: 81-3-5817-1050

ON Semiconductor Website: www.onsemi.com
Order Literature: <http://www.onsemi.com/orderlit>

For additional information, please contact your local Sales Representative



Компания «ЭлектроПласт» предлагает заключение долгосрочных отношений при поставках импортных электронных компонентов на взаимовыгодных условиях!

Наши преимущества:

- Оперативные поставки широкого спектра электронных компонентов отечественного и импортного производства напрямую от производителей и с крупнейших мировых складов;
- Поставка более 17-ти миллионов наименований электронных компонентов;
- Поставка сложных, дефицитных, либо снятых с производства позиций;
- Оперативные сроки поставки под заказ (от 5 рабочих дней);
- Экспресс доставка в любую точку России;
- Техническая поддержка проекта, помощь в подборе аналогов, поставка прототипов;
- Система менеджмента качества сертифицирована по Международному стандарту ISO 9001;
- Лицензия ФСБ на осуществление работ с использованием сведений, составляющих государственную тайну;
- Поставка специализированных компонентов (Xilinx, Altera, Analog Devices, Intersil, Interpoint, Microsemi, Aeroflex, Peregrine, Syfer, Eurofarad, Texas Instrument, Miteq, Cobham, E2V, MA-COM, Hittite, Mini-Circuits, General Dynamics и др.);

Помимо этого, одним из направлений компании «ЭлектроПласт» является направление «Источники питания». Мы предлагаем Вам помощь Конструкторского отдела:

- Подбор оптимального решения, техническое обоснование при выборе компонента;
- Подбор аналогов;
- Консультации по применению компонента;
- Поставка образцов и прототипов;
- Техническая поддержка проекта;
- Защита от снятия компонента с производства.



Как с нами связаться

Телефон: 8 (812) 309 58 32 (многоканальный)

Факс: 8 (812) 320-02-42

Электронная почта: org@eplast1.ru

Адрес: 198099, г. Санкт-Петербург, ул. Калинина, дом 2, корпус 4, литера А.