

THIS DOCUMENT IS SUBJECT TO CHANGE WITHOUT NOTICE. IT IS CONFIDENTIAL AND A PROPERTY OF Amphenol LTW. DISCLOSURE TO THIRD PARTY HAS TO BE AUTHORIZED BY Amphenol LTW.

REV.	ECN NO.	DATE	SIGN	DESCRIPTION
A	Initial Release	2016/07/25	Jason Yu	New Item

ALTW
CONFIDENTIAL
2016-07-25
R&D DEPT.

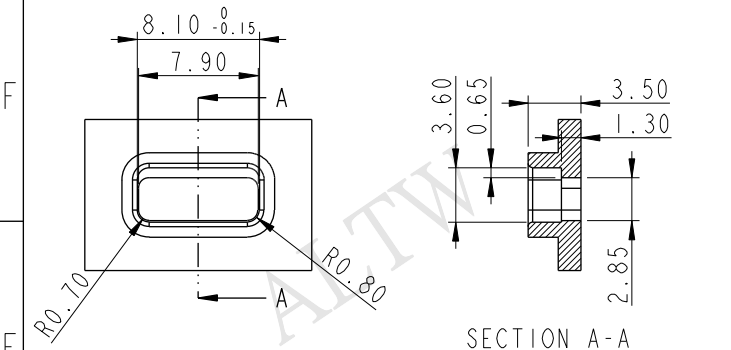

SECTION A-A

TOLERANCE Recommended Case Cut Out
 .XX±0.05 SCALE 2:1

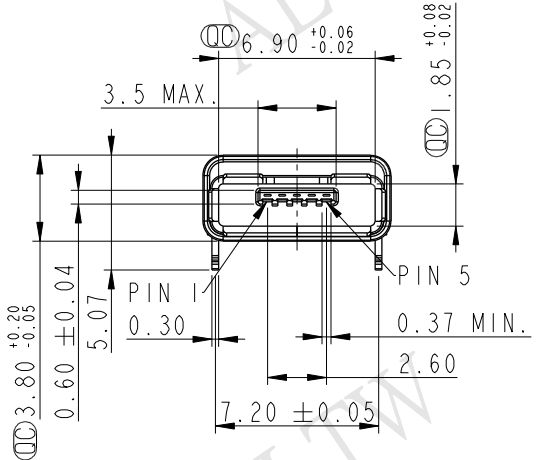
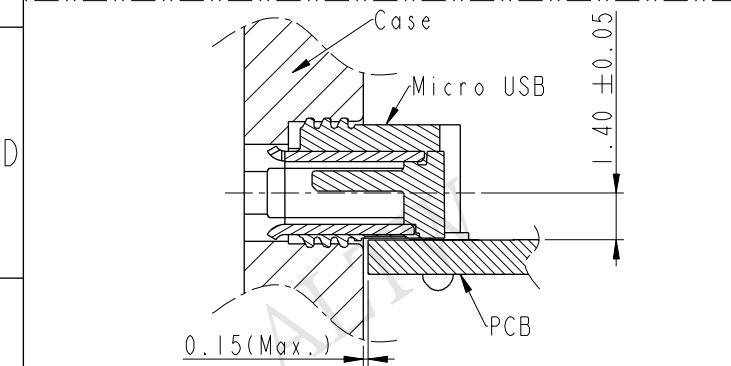

MUC-20PFFR-JSXX02

ALTW
DCC. DEPT.
CONFIDENTIAL
2016.07.27
ISSUED

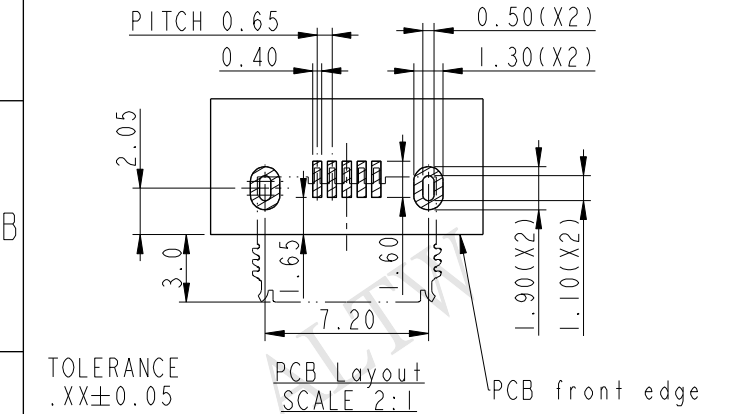
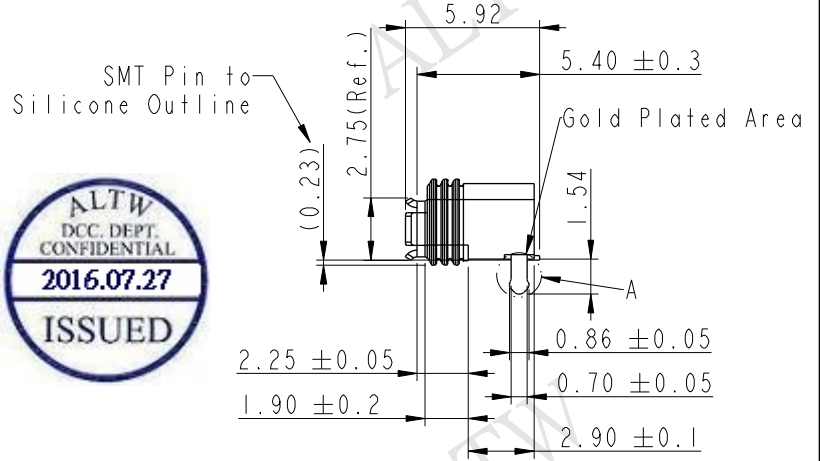

TOLERANCE
 .XX±0.05
 PCB Layout
 SCALE 2:1

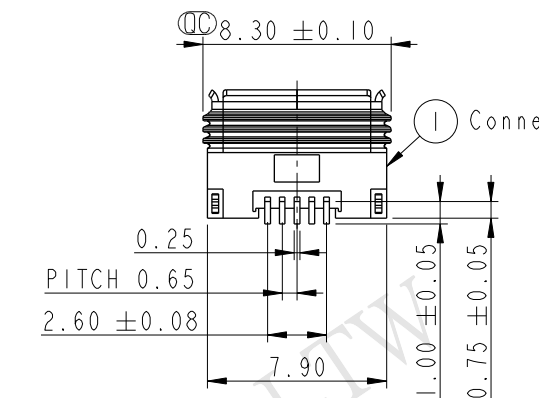

- †70: 1PX7(1M depth of water in 30min)
- †8A: 1PX8(1M depth of water in 24hrs)
- †8B: 1PX8(5M depth of water in 24hrs)
- †8C: 1PX8(10M depth of water in 3hrs)

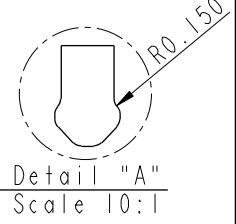

- Note:
- * (⊙) Important Dimensions To Check
 - * Current: 1&5pin(1.8A), 2~4 pin(1.0A)
 - * Housing: Nylon, Black
 - * Terminal: Copper Alloy, Gold Plated
 - * Shell: Stainless, Gold Plated
 - * Inner Gasket: Silicone, Transparent
 - * Outside Gasket: Silicone, Transparent
 - * PCB Thickness: 1.2 MAX.
 - * For Micro USB A & B type plug use
 - * SMD Temperature & Time: 260°C / 5 sec

UNIT: mm			TITLE WATERPROOF MICRO-AB USB PANEL 20MAB F CONN JACK LENGHT PIN			
TOLERANCE .X ±0.25 .XX ±0.1 .XXX ±0.05 ANGLES ±1°	SCALE 3:1	SIZE A4	SHEET 1	OF 4	REV. A	WC-REV. A.6
			QC: Inspection item			

Amphenol LTW
 安費諾亮泰企業股份有限公司

ITEM NO	DRAWN BY	DATE
DWG NO	CHECKED BY	DATE
CUSTOMER	APPROVED BY	DATE
ALTW	Jason Yu	2016/07/25
MUC-20PFFR-JSXX02	Arvin Chan	2016/07/25
ALTW	Kevin Hu	2016/07/25

THIS DOCUMENT IS SUBJECT TO CHANGE WITHOUT NOTICE. IT IS CONFIDENTIAL AND A PROPERTY OF AMPHENOL LTW. DISCLOSURE TO THIRD PARTY HAS TO BE AUTHORIZED BY AMPHENOL LTW.

Tape & Reel Information:

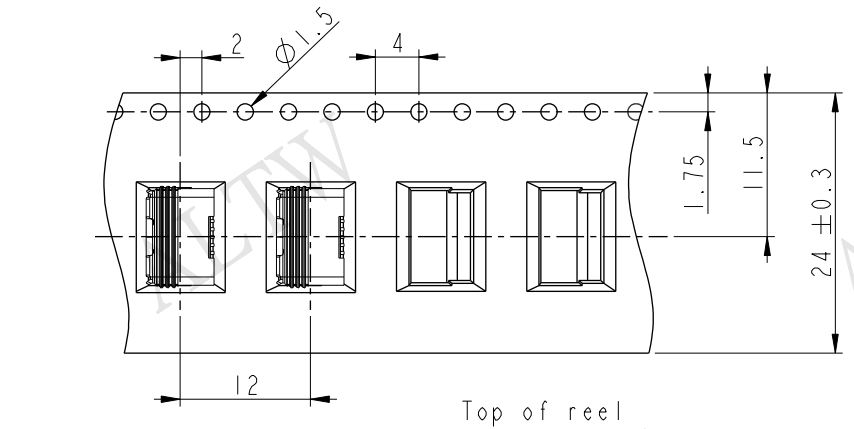

SMT Nozzle Area
(6.0x2.0mm)

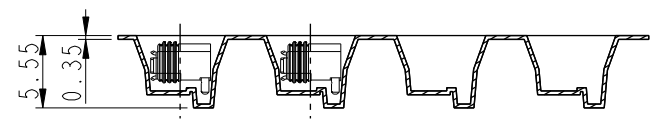
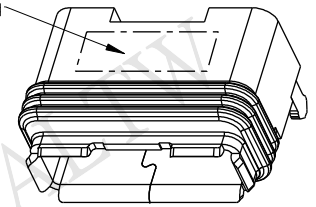

Wide cover tape around
out periphery 1 turn

Peeling strenght 0.1~1.3N Max.
(300±10mm/min)
Peeling angle
165~180°

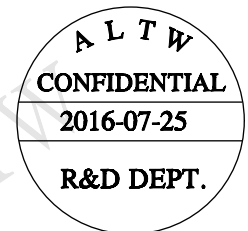
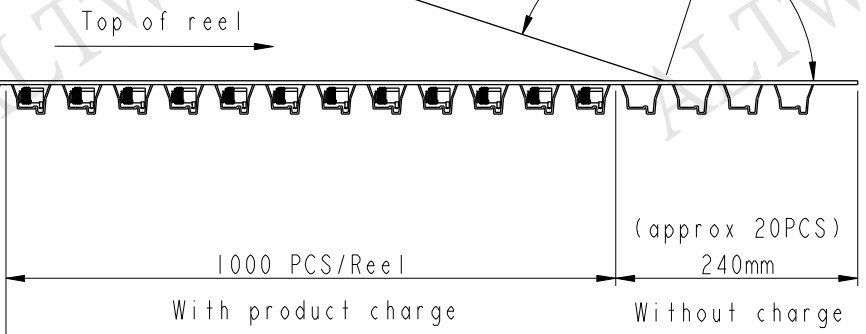
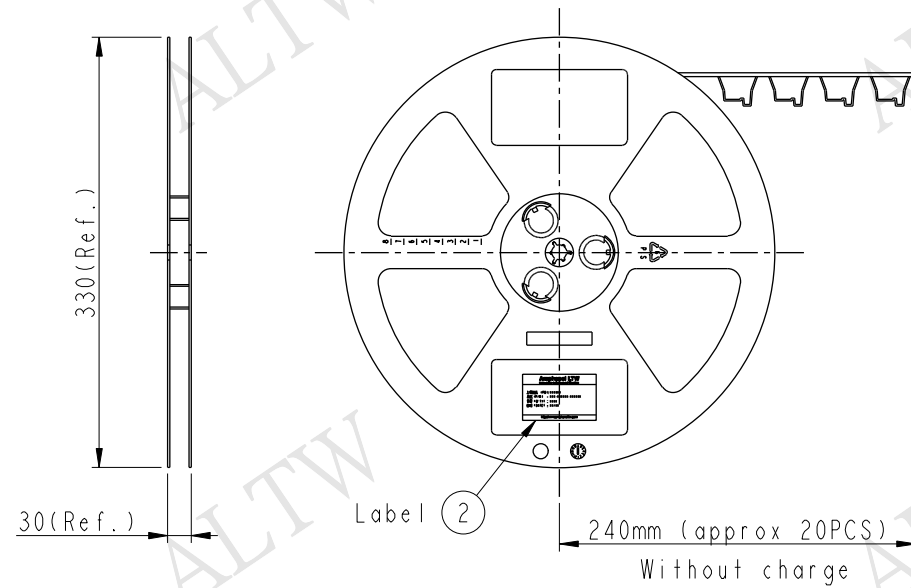

UNIT: mm		
TOLERANCE		
.X	±0.25	
.XX	±0.1	
.XXX	±0.05	
ANGLES	±1°	

TITLE WATERPROOF MICRO-AB USB PANEL 20MAB F CONN JACK LENGHT PIN			
SCALE	SIZE	SHEET	OF
Free	A4	2	4
REV.	WC-REV.	QC: Inspection item	
A	A.6		

Amphenol LTW
安費諾亮泰企業股份有限公司

ITEM NO	DRAWN BY	DATE
	Jason Yu	2016/07/25
DWG NO	CHECKED BY	DATE
MUC-20PFFR-JSXX02	Arvin Chan	2016/07/25
CUSTOMER	APPROVED BY	DATE
ALTW	Kevin Hu	2016/07/25

For SMT Process Recommend:

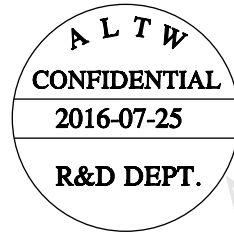

About Fixture:

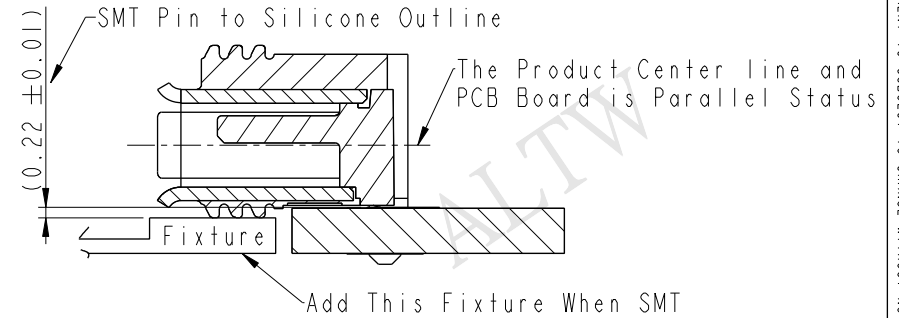

About IR Reflow Profile:

溫度設置 (攝氏)	1	2	3	4	5	6	7	8
溫區								
上溫區	160	180	180	180	190	245	265	260
下溫區	160	180	180	180	190	245	265	260
傳送帶速度 (米/分):	0.95							

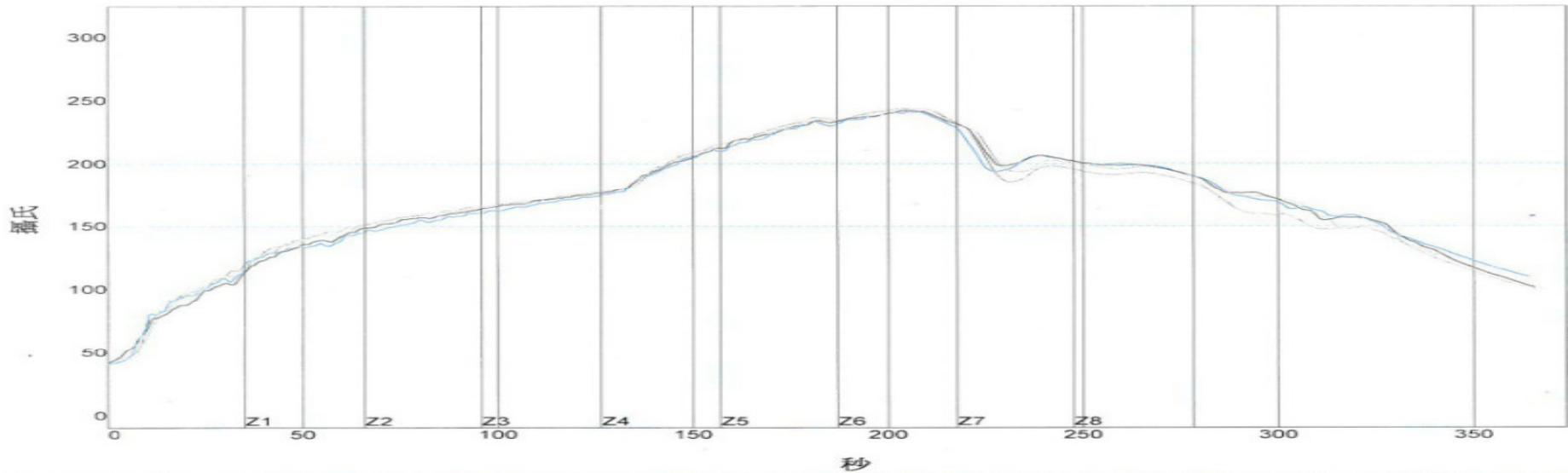

PWI= 61%	最高上升斜率	最高下降斜率	恆溫時間150至200C	回流時間 /220C	最高溫度					
CON1	2.81	-6%	-2.33	33%	80.21	-33%	60.91	-30%	242.36	-18%
CON2	2.38	-21%	-2.14	43%	75.61	-48%	57.41	-42%	241.74	-22%
CON3	2.81	-6%	-2.84	8%	77.79	-41%	58.66	-38%	243.44	-10%
CON4	2.83	-6%	-2.34	33%	72.24	-59%	51.64	-61%	240.92	-27%
溫差	0.45		0.70		7.97		9.27		2.52	

UNIT: mm

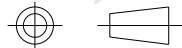

TITLE WATERPROOF MICRO-AB USB PANEL 20MAB F CONN JACK LENGTH PIN

Amphenol LTW
安費諾亮泰企業股份有限公司

ITEM NO	DRAWN BY	DATE
DWG NO	CHECKED BY	DATE
CUSTOMER	APPROVED BY	DATE

TOLERANCE	
.X	±0.25
.XX	±0.1
.XXX	±0.05
ANGLES	±1°

SCALE	Free	SIZE	A4	SHEET	3	OF	4
REV.	A	WC-REV.	A.1	☉: Inspection item			

THIS DOCUMENT IS SUBJECT TO CHANGE WITHOUT NOTICE. IT IS CONFIDENTIAL AND A PROPERTY OF Amphenol LTW. DISCLOSURE TO THIRD PARTY HAS TO BE AUTHORIZED BY Amphenol LTW.

Package :

One Carton can put in the 5PCS(Max.) Box

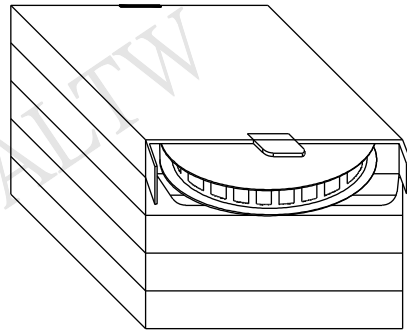

1000 PCS(Connector)/Tape&Reel, Put in a Box

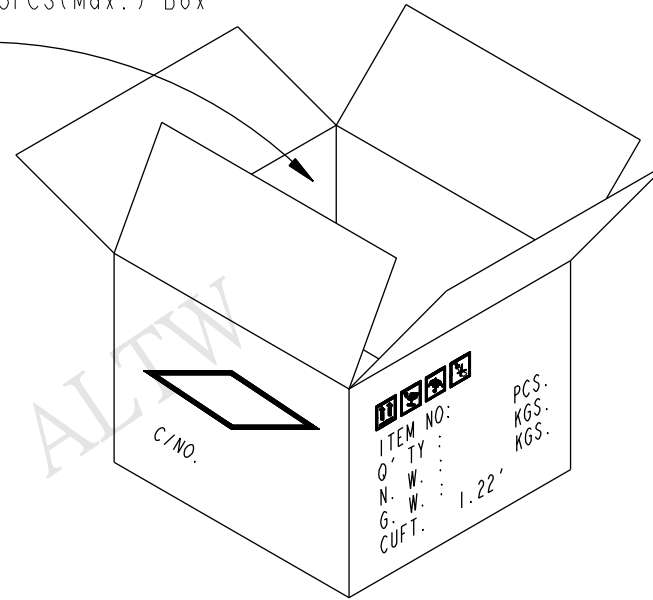

(5,000 PCS/Carton)

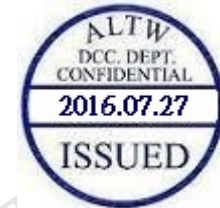
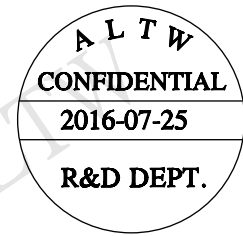

UNIT:mm

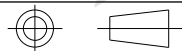

TOLERANCE
 .X ±0.25
 .XX ±0.1
 .XXX ±0.05
 ANGLES ±1°

TITLE
 WATERPROOF MICRO-AB USB
 PANEL 20MAB F CONN JACK LENGHT PIN

SCALE Free SIZE A4 SHEET 4 OF 4
 REV. A WC-REV. A.1 (QC):Inspection item

Amphenol LTW
 安費諾亮泰企業股份有限公司

ITEM NO
 DWG NO MUC-20PFFR-JSXX02
 CUSTOMER ALTW

DRAWN BY Jason Yu
 CHECKED BY Arvin Chan
 APPROVED BY Kevin Hu

DATE 2016/07/25
 DATE 2016/07/25
 DATE 2016/07/25

THIS DOCUMENT IS SUBJECT TO CHANGE WITHOUT NOTICE. IT IS CONFIDENTIAL AND A PROPERTY OF Amphenol LTW. DISCLOSURE TO THIRD PARTY HAS TO BE AUTHORIZED BY Amphenol LTW.



Компания «ЭлектроПласт» предлагает заключение долгосрочных отношений при поставках импортных электронных компонентов на взаимовыгодных условиях!

Наши преимущества:

- Оперативные поставки широкого спектра электронных компонентов отечественного и импортного производства напрямую от производителей и с крупнейших мировых складов;
- Поставка более 17-ти миллионов наименований электронных компонентов;
- Поставка сложных, дефицитных, либо снятых с производства позиций;
- Оперативные сроки поставки под заказ (от 5 рабочих дней);
- Экспресс доставка в любую точку России;
- Техническая поддержка проекта, помощь в подборе аналогов, поставка прототипов;
- Система менеджмента качества сертифицирована по Международному стандарту ISO 9001;
- Лицензия ФСБ на осуществление работ с использованием сведений, составляющих государственную тайну;
- Поставка специализированных компонентов (Xilinx, Altera, Analog Devices, Intersil, Interpoint, Microsemi, Aeroflex, Peregrine, Syfer, Eurofarad, Texas Instrument, Miteq, Cobham, E2V, MA-COM, Hittite, Mini-Circuits, General Dynamics и др.);

Помимо этого, одним из направлений компании «ЭлектроПласт» является направление «Источники питания». Мы предлагаем Вам помощь Конструкторского отдела:

- Подбор оптимального решения, техническое обоснование при выборе компонента;
- Подбор аналогов;
- Консультации по применению компонента;
- Поставка образцов и прототипов;
- Техническая поддержка проекта;
- Защита от снятия компонента с производства.



Как с нами связаться

Телефон: 8 (812) 309 58 32 (многоканальный)

Факс: 8 (812) 320-02-42

Электронная почта: org@eplast1.ru

Адрес: 198099, г. Санкт-Петербург, ул. Калинина, дом 2, корпус 4, литера А.