



Low-Voltage, Quad, Hot-Swap Controllers/Power Sequencers

General Description

The MAX5927A/MAX5929A–MAX5929D +1V to +15V quad hot-swap controllers provide complete protection for multisupply systems. They allow the safe insertion and removal of circuit cards into live backplanes. These devices hot swap multiple supplies ranging from +1V to +15V, provided one supply is at or above +2.7V. The input voltage rails (channels) can be configured to sequentially turn-on/off, track each other, or have completely independent operation.

The discharged filter capacitors of the circuit card provide low impedance to the live backplane. High inrush currents from the backplane to the circuit card can burn up connectors and components, or momentarily collapse the backplane power supply leading to a system reset. The MAX5927A/MAX5929A–MAX5929D hot-swap controllers prevent such problems by gradually ramping up the output voltage and regulating the current to a preset limit when the board is plugged in, allowing the system to stabilize safely. After the startup cycle is complete, on-chip comparators provide VariableSpeed/BiLevel™ protection against short-circuit and overcurrent faults, and provide immunity against system noise and load transients. The load is disconnected in the event of a fault condition. The MAX5929C/MAX5929D automatically restart after a fault condition, while the MAX5929A/MAX5929B must be unlatched. The MAX5927A fault management mode is selectable.

The MAX5927A/MAX5929A–MAX5929D offer a variety of options to reduce external component count and design time. All devices integrate an on-board charge pump to drive the gates of low-cost external n-channel MOSFETs, an adjustable startup timer, and an adjustable current limit. The devices offer integrated features like startup current regulation and current glitch protection to eliminate external timing resistors and capacitors. The MAX5929B/MAX5929D provide an open-drain, active-low status output for each channel, the MAX5929A/MAX5929C provide an open-drain, active-high status output for each channel, and the MAX5927A status output polarity is selectable.

The MAX5927A is available in a 32-pin thin QFN package and the MAX5929A–MAX5929D are available in a 24-pin QSOP package. All devices are specified over the -40°C to +85°C extended temperature range.

Applications

PCI Express® Hot Plug	Basestation Line Cards
Hot Plug-In Daughter Cards	Portable Computer Device Bays (Docking Stations)
RAID	Network Switches, Routers, Hubs
Power-Supply Sequencing/Tracking	

VariableSpeed/BiLevel is a trademark of Maxim Integrated Products, Inc.

PCI Express is a registered trademark of PCI-SIG Corp. trademark



Features

- ◆ Safe Hot Swap for +1V to +15V Power Supplies with Any Input Voltage ($V_{IN} \geq 2.7V$)
- ◆ Adjustable Circuit-Breaker/Current-Limit Threshold from 25mV to 100mV
- ◆ Configurable Tracking, Sequencing, or Independent Operation Modes
- ◆ VariableSpeed/BiLevel Circuit-Breaker Response
- ◆ Internal Charge Pumps Generate n-Channel MOSFET Gate Drives
- ◆ Inrush Current Regulated at Startup
- ◆ Autoretry or Latched Fault Management
- ◆ Programmable Undervoltage Lockout
- ◆ Status Outputs Indicate Fault/Safe Condition

Ordering Information

PART	TEMP RANGE	PIN-PACKAGE
MAX5927AETJ+	-40°C to +85°C	32 Thin QFN-EP*
MAX5929AEEG+	-40°C to +85°C	24 QSOP
MAX5929BEEG+	-40°C to +85°C	24 QSOP
MAX5929CEEG+	-40°C to +85°C	24 QSOP
MAX5929DEEG+	-40°C to +85°C	24 QSOP

*EP = Exposed pad.

+Denotes a lead-free/RoHS-compliant package.

Selector Guide and Typical Operating Circuit appear at end of data sheet.

Pin Configurations

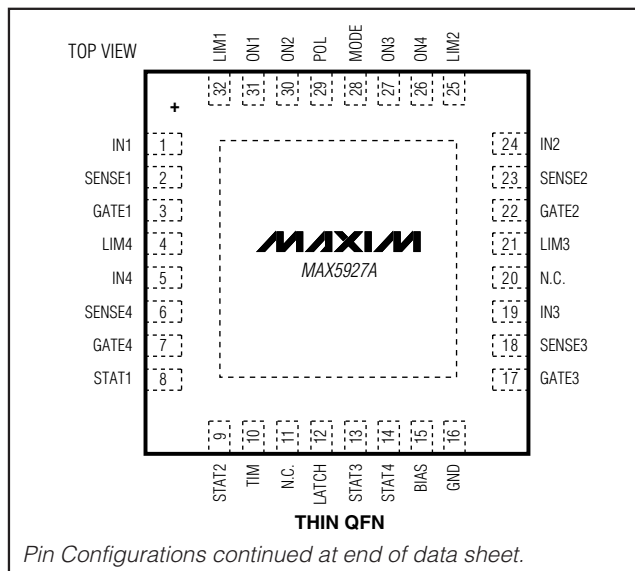

MAX5927A/MAX5929A–MAX5929D

Low-Voltage, Quad, Hot-Swap Controllers/Power Sequencers

ABSOLUTE MAXIMUM RATINGS

(All voltages referenced to GND, unless otherwise noted.)

IN_	-0.3V to +16V
GATE_	-0.3V to (IN_ + 6V)
BIAS (Note 1)	(VIN - 0.3V) to +16V
ON_, STAT_, LIM_ (MAX5927A), TIM, MODE, LATCH (MAX5927A), POL (MAX5927A) (Note 1)	-0.3V to (VIN + 0.3V)
SENSE_	-0.3V to (IN_ + 0.3V)
Current into Any Pin	±50mA

Continuous Power Dissipation (TA = +70°C)

24-Pin QSOP (derate 9.5mW/°C above +70°C)	762mW
32-Pin Thin QFN (derate 21.3mW/°C above +70°C)	1702mW
Operating Temperature Range	-40°C to +85°C
Junction Temperature	+150°C
Storage Temperature Range	-65°C to +150°C
Lead Temperature (soldering, 10s)	+300°C

Note 1: VIN is the largest of VIN1, VIN2, VIN3, and VIN4.

Stresses beyond those listed under "Absolute Maximum Ratings" may cause permanent damage to the device. These are stress ratings only, and functional operation of the device at these or any other conditions beyond those indicated in the operational sections of the specifications is not implied. Exposure to absolute maximum rating conditions for extended periods may affect device reliability.

ELECTRICAL CHARACTERISTICS

(VIN_ = +1V to +15V provided at least one supply is larger than or equal to +2.7V, TA = -40°C to +85°C, unless otherwise noted. Typical values are at VIN1 = 12.0V, VIN2 = 5.0V, VIN3 = 3.3V, VIN4 = 1.0V, VON_ = +3.3V, and TA = +25°C.) (Notes 1, 2)

PARAMETER	SYMBOL	CONDITIONS	MIN	TYP	MAX	UNITS
POWER SUPPLIES						
IN_ Input Voltage Range	VIN_	At least one VIN_	1.0		15	V
Supply Current	IQ	IIN1 + IIN2 + IIN3 + IIN4, VON_ = 2.7V, VIN_ = +15V, after STAT_ asserts		2.5	5	mA
CURRENT CONTROL						
Slow-Comparator Threshold (VIN_ - VSENSE_) (Note 3)	VSC,TH	LIM_ = GND, MAX5927A/ MAX5929A-MAX5929D (Note 4)	22.5	25	28	mV
		RLIM_ = 10kΩ (MAX5927A)	80		125	
		RLIM_ from LIM_ to GND (MAX5927A)	RLIM_ x 7.5 x 10 ⁻⁶ + 25mV			
Slow-Comparator Response Time (Note 4)	tSCD	1mV overdrive		3		ms
		50mV overdrive		130		μs
Fast-Comparator Threshold (VIN_ - VSENSE_)	VFC,TH			2 x VSC,TH		mV
Fast-Comparator Response Time	tFCD	10mV overdrive, from overload condition		200		ns
SENSE_ Input Bias Current	IB SENSE_	VSENSE_ = VIN_		0.03	1	μA

Low-Voltage, Quad, Hot-Swap Controllers/Power Sequencers

MAX5927A/MAX5929A-MAX5929D

ELECTRICAL CHARACTERISTICS (continued)

($V_{IN_}$ = +1V to +15V provided at least one supply is larger than or equal to +2.7V, T_A = -40°C to +85°C, unless otherwise noted. Typical values are at V_{IN1} = 12.0V, V_{IN2} = 5.0V, V_{IN3} = 3.3V, V_{IN4} = 1.0V, $V_{ON_}$ = +3.3V, and T_A = +25°C.) (Notes 1, 2)

PARAMETER	SYMBOL	CONDITIONS	MIN	TYP	MAX	UNITS
MOSFET DRIVER						
Startup Period (Note 5)	t_{START}	$R_{TIM} = 100k\Omega$	8.0	10.8	13.6	ms
		$R_{TIM} = 4k\Omega$ (minimum value)	0.30	0.4	0.55	
		TIM floating (default)	5	9	14	
Average Gate Current	I_{GATE}	Charging, $V_{GATE_} = GND$, $V_{IN_} = 5V$ (Note 6)	80	100	125	μA
		Discharging, during startup		100		
		Discharging, normal turn-off or triggered by the slow comparator after startup, $V_{GATE_} = 5V$, $V_{IN_} = 10V$, $V_{ON_} = 0V$	2	3	7	mA
		Discharging, triggered by a fault after startup, $V_{GATE_} = 5V$, $V_{IN_} = 10V$, $(V_{IN_} - V_{SENSE_}) > V_{FC,TH}$ (Note 7)	28	50	120	
Gate-Drive Voltage	V_{DRIVE}	$V_{GATE_} - V_{IN_}$, $I_{GATE_} = 1\mu A$	4.9	5.3	5.6	V
ON COMPARATOR						
ON_ Threshold	V_{ON_TH}	Low to high	0.83	0.875	0.90	V
		Hysteresis		25		mV
ON_ Propagation Delay		10mV overdrive		10		μs
ON_ Voltage Range	$V_{ON_}$	Without false output inversion			V_{IN}	V
ON_ Input Bias Current	$I_{BON_}$	$V_{ON_} = V_{IN}$		0.03	1	μA
ON_ Pulse Width Low	$t_{UNLATCH}$	To unlatch after a latched fault	100			μs
DIGITAL OUTPUTS (STAT_)						
Output Leakage Current		$V_{STAT_} \leq 15V$			1	μA
Output Voltage Low	$V_{OL_}$	POL = unconnected (MAX5927A), $I_{SINK} = 1mA$			0.4	V
UNDERVOLTAGE LOCKOUT (UVLO)						
UVLO Threshold	V_{UVLO}	Startup is initiated when this threshold is reached by any $V_{IN_}$ and $V_{ON_} > 0.9V$ (Note 8)	2.25		2.65	V
UVLO Hysteresis	$V_{UVLO,HYST}$			250		mV
UVLO Glitch Filter Reset Time	$t_{D,GF}$	$V_{IN} < V_{UVLO}$ maximum pulse width to reset			10	μs
UVLO to Startup Delay	$t_{D,UVLO}$	Time input voltage must exceed V_{UVLO} before startup is initiated	20	37.5	60	ms
Input Power-Ready Threshold	V_{PWRRDY}	(Note 9)	0.9	0.95	1.0	V
Input Power-Ready Hysteresis	$V_{PWRHYST}$			50		mV

Low-Voltage, Quad, Hot-Swap Controllers/Power Sequencers

ELECTRICAL CHARACTERISTICS (continued)

($V_{IN_}$ = +1V to +15V provided at least one supply is larger than or equal to +2.7V, T_A = -40°C to +85°C, unless otherwise noted. Typical values are at V_{IN1} = 12.0V, V_{IN2} = 5.0V, V_{IN3} = 3.3V, V_{IN4} = 1.0V, $V_{ON_}$ = +3.3V, and T_A = +25°C.) (Notes 1, 2)

PARAMETER	SYMBOL	CONDITIONS	MIN	TYP	MAX	UNITS
LOGIC AND TIMING						
POL Input Pullup	I_{POL}	POL = GND (MAX5927A)	2	4	6	μA
LATCH Input Pullup	I_{LATCH}	LATCH = GND (MAX5927A)	2	4	6	μA
MODE Input Voltage	V_{MODE}	MODE unconnected (default to sequencing mode)	1.0	1.25	1.5	V
Independent Mode Selection Threshold	$V_{INDEP, TH}$	V_{MODE} rising			0.4	V
Tracking Mode Selection Threshold	$V_{TRACK, TH}$	V_{MODE} rising	2.7			V
MODE Input Impedance	R_{MODE}			200		$k\Omega$
Autoretry Delay	t_{RETRY}	Delay time to restart after fault shutdown		64 x t_{START}		ms

Note 2: All devices are 100% tested at T_A = +85°C. Limits over temperature are guaranteed by design.

Note 3: The slow-comparator threshold is adjustable. $V_{SC, TH} = R_{LIM} \times 7.5\mu A + 25mV$ (see the *Typical Operating Characteristics*).

Note 4: The current-limit slow-comparator response time is weighed against the amount of overcurrent—the higher the overcurrent condition, the faster the response time (see the *Typical Operating Characteristics*).

Note 5: The startup period (t_{START}) is the time during which the slow comparator is ignored and the device acts as a current limiter by regulating the sense current with the fast comparator (see the *Startup Period* section).

Note 6: The current available at GATE is a function of V_{GATE} (see the *Typical Operating Characteristics*).

Note 7: After a fault triggered by the fast comparator, the gate is discharged by the strong discharge current.

Note 8: Each channel input while the other inputs are at +1V.

Note 9: Each channel input while any other input is at +3.3V.

Typical Operating Characteristics

(*Typical Operating Circuit*, Q1 = Q2 = Q3 = Q4 = Fairchild FDB7090L, V_{IN1} = 12V, V_{IN2} = 5.0V, V_{IN3} = 3.3V, V_{IN4} = 1.0V, T_A = +25°C, unless otherwise noted. Channels 1 through 4 are identical in performance. Where characteristics are interchangeable, channels 1 through 4 are referred to as W, X, Y, and Z.)

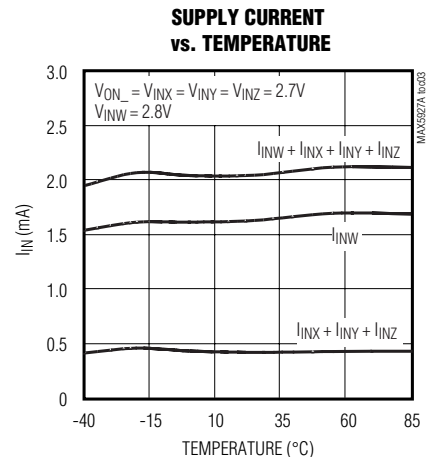
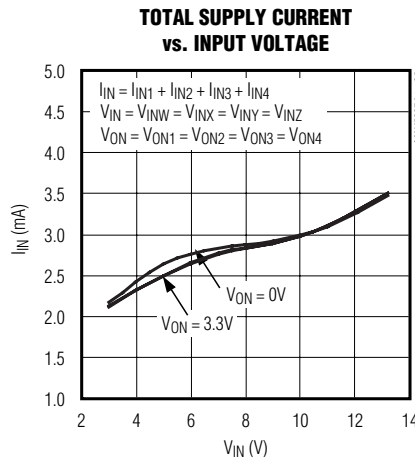
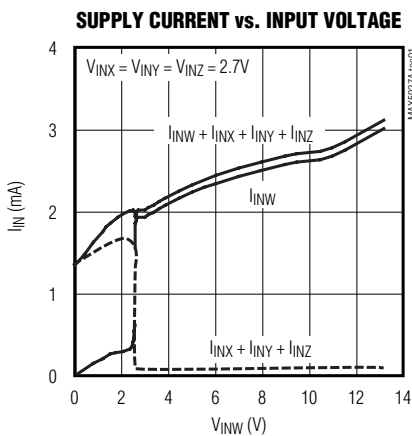

Low-Voltage, Quad, Hot-Swap Controllers/Power Sequencers

Typical Operating Characteristics (continued)

(Typical Operating Circuit, Q1 = Q2 = Q3 = Q4 = Fairchild FDB7090L, $V_{IN1} = 12V$, $V_{IN2} = 5.0V$, $V_{IN3} = 3.3V$, $V_{IN4} = 1.0V$, $T_A = +25^\circ C$, unless otherwise noted. Channels 1 through 4 are identical in performance. Where characteristics are interchangeable, channels 1 through 4 are referred to as W, X, Y, and Z.)

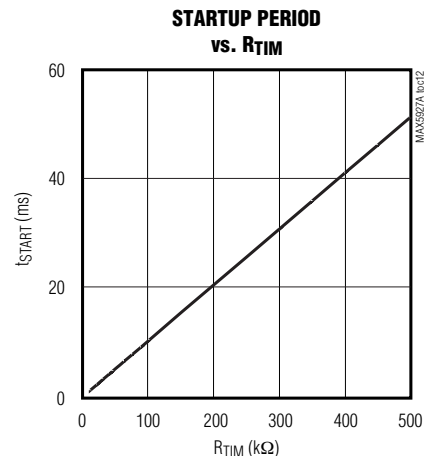
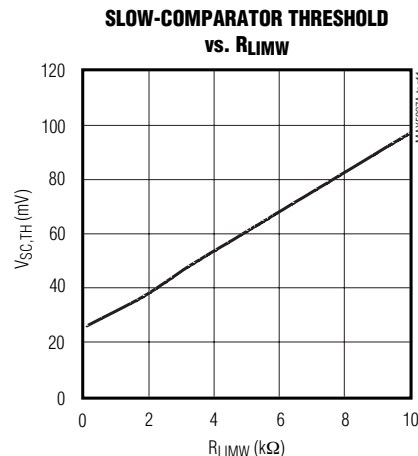
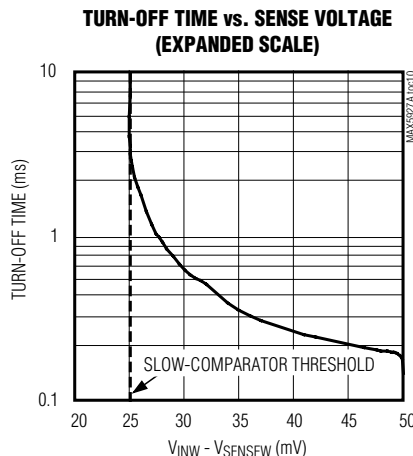
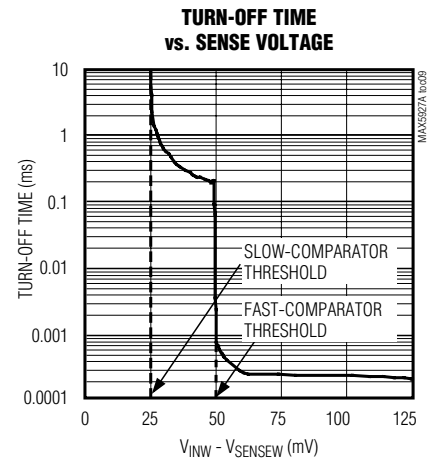
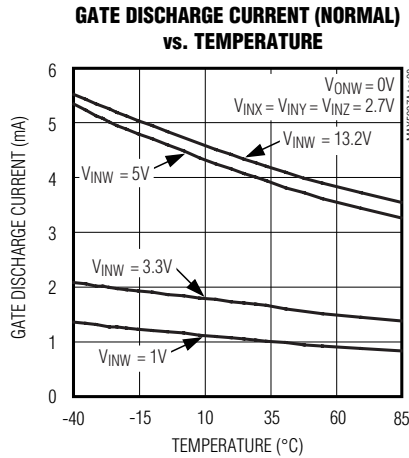
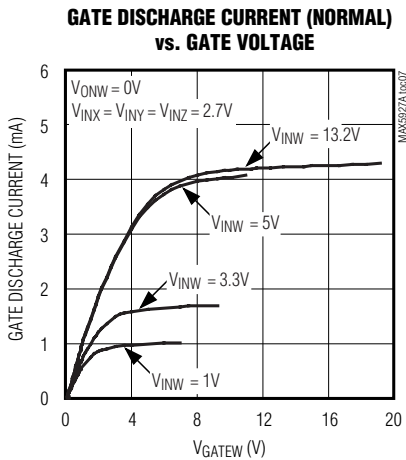
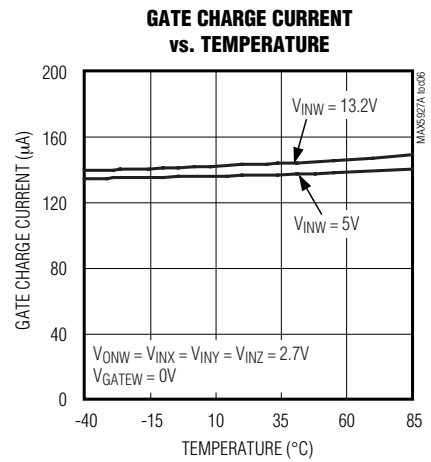
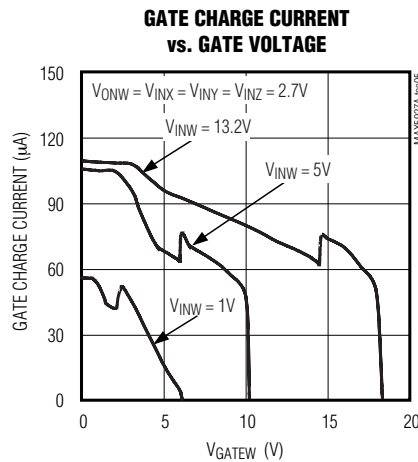
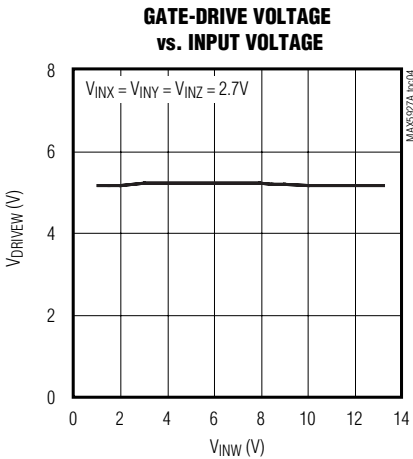

MAX5927A/MAX5929A-MAX5929D

Low-Voltage, Quad, Hot-Swap Controllers/Power Sequencers

Typical Operating Characteristics (continued)

(Typical Operating Circuit, Q1 = Q2 = Q3 = Q4 = Fairchild FDB7090L, $V_{IN1} = 12V$, $V_{IN2} = 5.0V$, $V_{IN3} = 3.3V$, $V_{IN4} = 1.0V$, $T_A = +25^\circ C$, unless otherwise noted. Channels 1 through 4 are identical in performance. Where characteristics are interchangeable, channels 1 through 4 are referred to as W, X, Y, and Z.)

**TURN-OFF TIME
SLOW-COMPARATOR FAULT**

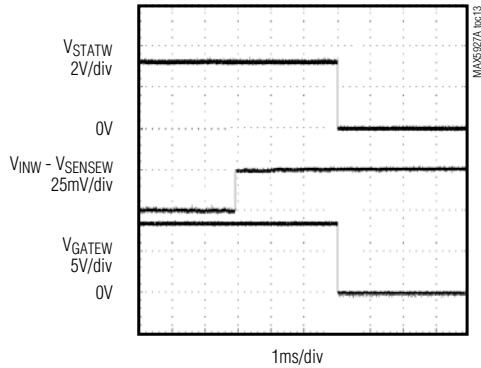

**TURN-OFF TIME
FAST-COMPARATOR FAULT**

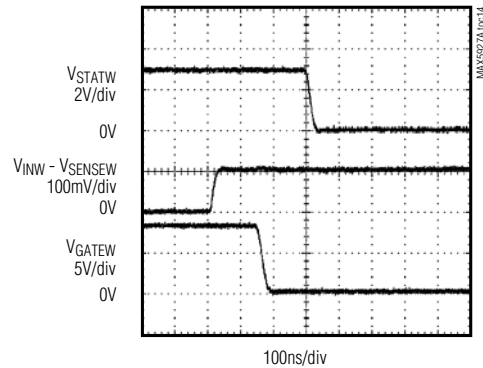

**STARTUP WAVEFORMS FAST TURN-ON
(C_GATE = 0nF, C_BOARD = 1000µF)**

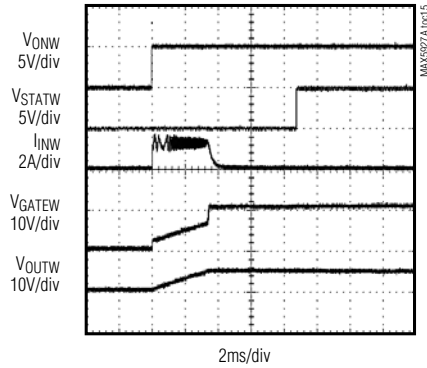

**STARTUP WAVEFORMS SLOW TURN-ON
(C_GATE = 0.22µF, C_BOARD = 1000µF)**

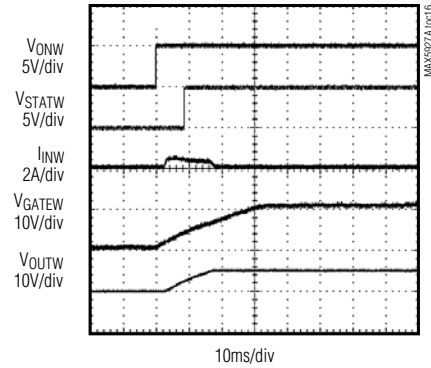

AUTORETRY DELAY (TIME FLOATING)

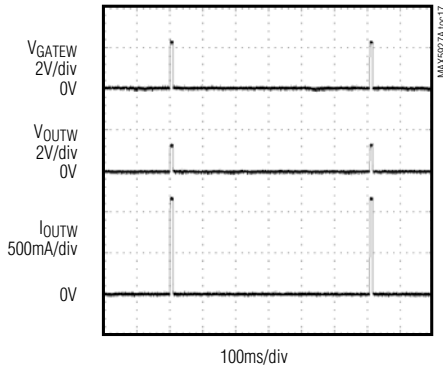

**TURN-ON IN
VOLTAGE-TRACKING MODE**

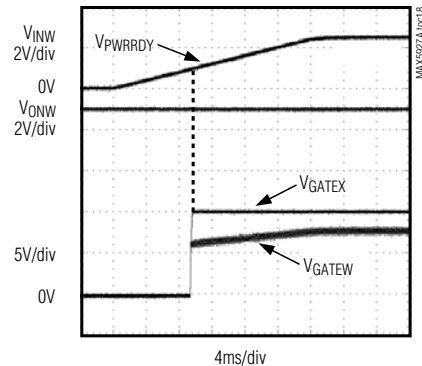

Low-Voltage, Quad, Hot-Swap Controllers/Power Sequencers

Typical Operating Characteristics (continued)

(Typical Operating Circuit, Q1 = Q2 = Q3 = Q4 = Fairchild FDB7090L, $V_{IN1} = 12V$, $V_{IN2} = 5.0V$, $V_{IN3} = 3.3V$, $V_{IN4} = 1.0V$, $T_A = +25^\circ C$, unless otherwise noted. Channels 1 through 4 are identical in performance. Where characteristics are interchangeable, channels 1 through 4 are referred to as W, X, Y, and Z.)

TURN-OFF IN VOLTAGE-TRACKING MODE

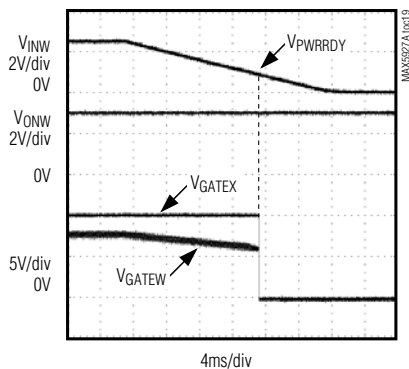

TURN-ON IN POWER-SEQUENCING MODE

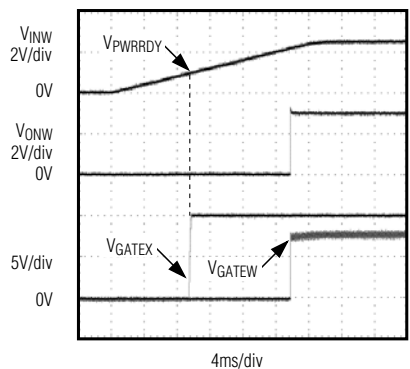

TURN-OFF IN POWER-SEQUENCING MODE

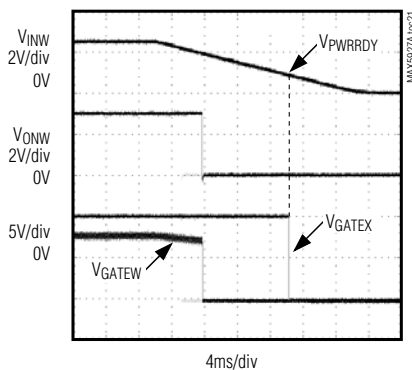

TURN-ON IN INDEPENDENT MODE

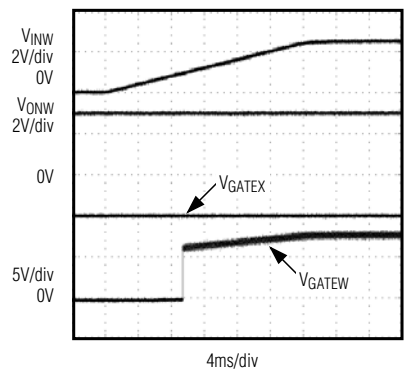

TURN-OFF IN INDEPENDENT MODE

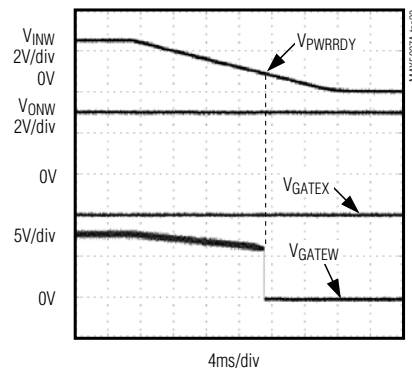

STRONG GATE DISCHARGE CURRENT vs. OVERDRIVE

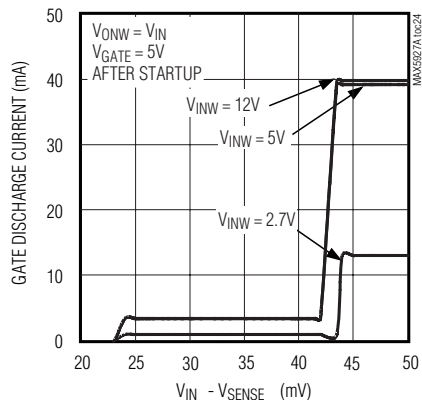

MAX5927A/MAX5929A-MAX5929D

Low-Voltage, Quad, Hot-Swap Controllers/Power Sequencers

Pin Description

PIN		NAME	FUNCTION
MAX5927A	MAX5929A-MAX5929D		
1	4	IN1	Channel 1 Supply Input. Connect to a supply voltage from 1V to 15V and to one end of R _{SENSE1} . Bypass with a 0.1μF capacitor to ground.
2	5	SENSE1	Channel 1 Current-Sense Input. Connect SENSE1 to the drain of an external MOSFET and to one end of R _{SENSE1} .
3	6	GATE1	Channel 1 Gate-Drive Output. Connect to gate of external n-channel MOSFET.
4	—	LIM4	Channel 4 Current-Limit Setting. Connect a resistor from LIM4 to GND to set current-trip level. Connect to GND for the default 25mV threshold. Do not leave unconnected.
5	7	IN4	Channel 4 Supply Input. Connect to a supply voltage from 1V to 15V and to one end of R _{SENSE4} . Bypass with a 0.1μF capacitor to ground.
6	8	SENSE4	Channel 4 Current-Sense Input. Connect SENSE4 to the drain of an external MOSFET and to one end of R _{SENSE4} .
7	9	GATE4	Channel 4 Gate-Drive Output. Connect to gate of external n-channel MOSFET.
8	10	STAT1	Open-Drain Status Signal for Channel 1. STAT1 asserts when hot swap is successful and t _{START} has elapsed. STAT1 deasserts if ON1 is low, or if channel 1 is turned off for any fault condition.
9	11	STAT2	Open-Drain Status Signal for Channel 2. STAT2 asserts when hot swap is successful and t _{START} has elapsed. STAT2 deasserts if ON2 is low, or if channel 2 is turned off for any fault condition.
10	12	TIM	Startup Timer Setting. Connect a resistor from TIM to GND to set the startup period. Leave TIM unconnected for the default startup period of 9ms. R _{TIM} must be between 4kΩ and 500kΩ.
11, 20	—	N.C.	No Connection. Not internally connected.
12	—	LATCH	Latch/Autoretry Selection Input. Connect LATCH to GND for autoretry mode after a fault. Leave LATCH unconnected for latch mode.
13	13	STAT3	Open-Drain Status Signal for Channel 3. STAT3 asserts when hot swap is successful and t _{START} has elapsed. STAT3 deasserts if ON3 is low, or if channel 3 is turned off for any fault condition.
14	14	STAT4	Open-Drain Status Signal for Channel 4. STAT4 asserts when hot swap is successful and t _{START} has elapsed. STAT4 deasserts if ON4 is low, or if channel 4 is turned off for any fault condition.
15	15	BIAS	Supply Reference Output. The highest supply is available at BIAS for filtering. Connect a 1nF to 10nF ceramic capacitor from BIAS to GND. No other connections are allowed to this pin.
16	16	GND	Ground
17	17	GATE3	Channel 3 Gate-Drive Output. Connect to gate of external n-channel MOSFET.
18	18	SENSE3	Channel 3 Current-Sense Input. Connect SENSE3 to the drain of an external MOSFET and to one end of R _{SENSE3} .
19	19	IN3	Channel 3 Supply Input. Connect to a supply voltage from 1V to 15V and to one end of R _{SENSE3} .
21	—	LIM3	Channel 3 Current-Limit Setting. Connect a resistor from LIM3 to GND to set current-trip level. Connect to GND for the default 25mV threshold. Do not leave unconnected.

Low-Voltage, Quad, Hot-Swap Controllers/Power Sequencers

Pin Description (continued)

PIN		NAME	FUNCTION
MAX5927A	MAX5929A–MAX5929D		
22	20	GATE2	Channel 2 Gate-Drive Output. Connect to gate of external n-channel MOSFET.
23	21	SENSE2	Channel 2 Current-Sense Input. Connect SENSE2 to the drain of an external MOSFET and to one end of R _{SENSE2} .
24	22	IN2	Channel 2 Supply Input. Connect to a supply voltage from 1V to 15V and to one end of R _{SENSE2} .
25	—	LIM2	Channel 2 Current-Limit Setting. Connect a resistor from LIM2 to GND to set the current-trip level. Connect to GND for the default 25mV threshold. Do not leave unconnected.
26	23	ON4	On/Off Channel 4 Control Input. See the <i>Mode</i> section.
27	24	ON3	On/Off Channel 3 Control Input. See the <i>Mode</i> section.
28	1	MODE	Mode Configuration Input. Mode is configured according to Table 1 as soon as one of the IN_ voltages exceeds UVLO and before turning on OUT_. See the <i>Mode</i> section.
29	—	POL	STAT Output Polarity Select. See Table 3 and the <i>Status Output</i> section.
30	2	ON2	On/Off Channel 2 Control Input. See the <i>Mode</i> section.
31	3	ON1	On/Off Channel 1 Control Input. See the <i>Mode</i> section.
32	—	LIM1	Channel 1 Current-Limit Setting. Connect a resistor from LIM1 to GND to set the current-trip level. Connect to GND for the default 25mV threshold. Do not leave unconnected.
EP	—	EP	Exposed Pad. EP is internally connected to GND. Leave EP unconnected or connect to GND.

Detailed Description

The MAX5927A/MAX5929A–MAX5929D are circuit-breaker ICs for hot-swap applications where a line card is inserted into a live backplane. The MAX5927A/MAX5929A–MAX5929D operate down to 1V provided one of the inputs is at or $\geq 2.7V$. Normally, when a line card is plugged into a live backplane, the card's discharged filter capacitors provide low impedance that can momentarily cause the main power supply to collapse. MAX5927A/MAX5929A–MAX5929D reside either on the backplane or on the removable card to provide inrush current limiting and short-circuit protection. This is achieved by using external n-channel MOSFETs, external current-sense resistors, and on-chip comparators. The startup period and current-limit threshold of the MAX5927A/MAX5929A–MAX5929D can be adjusted with external resistors. Figure 1 shows the MAX5927A/MAX5929A–MAX5929D functional diagram.

The MAX5927A offers four programmable current limits, selectable fault management mode, and selectable STAT_ output polarity. The MAX5929A–MAX5929D feature fixed current limits, and a variety of fault management and STAT_ polarity option combinations.

Mode

The MAX5927A/MAX5929A–MAX5929D support three modes of operation: voltage tracking, power sequencing, and independent. Select the appropriate mode according to Table 1.

Voltage-Tracking Mode

Connect MODE high to enter voltage-tracking mode. While in voltage-tracking mode, all channels turn on and off together. To turn all channels on:

- At least one V_{IN_} must exceed V_{UVLO} (2.45V) for the UVLO to startup delay (37.5ms).
- All V_{IN_} must exceed V_{PWRDY} (0.95V).
- All V_{ON_} must exceed V_{ON,TH} (0.875V).
- No faults may be present on any channel.

Table 1. Operational Mode Selection

MODE	OPERATION
High (connect to BIAS)	Voltage tracking
Unconnected	Power sequencing
GND	Independent

Low-Voltage, Quad, Hot-Swap Controllers/Power Sequencers

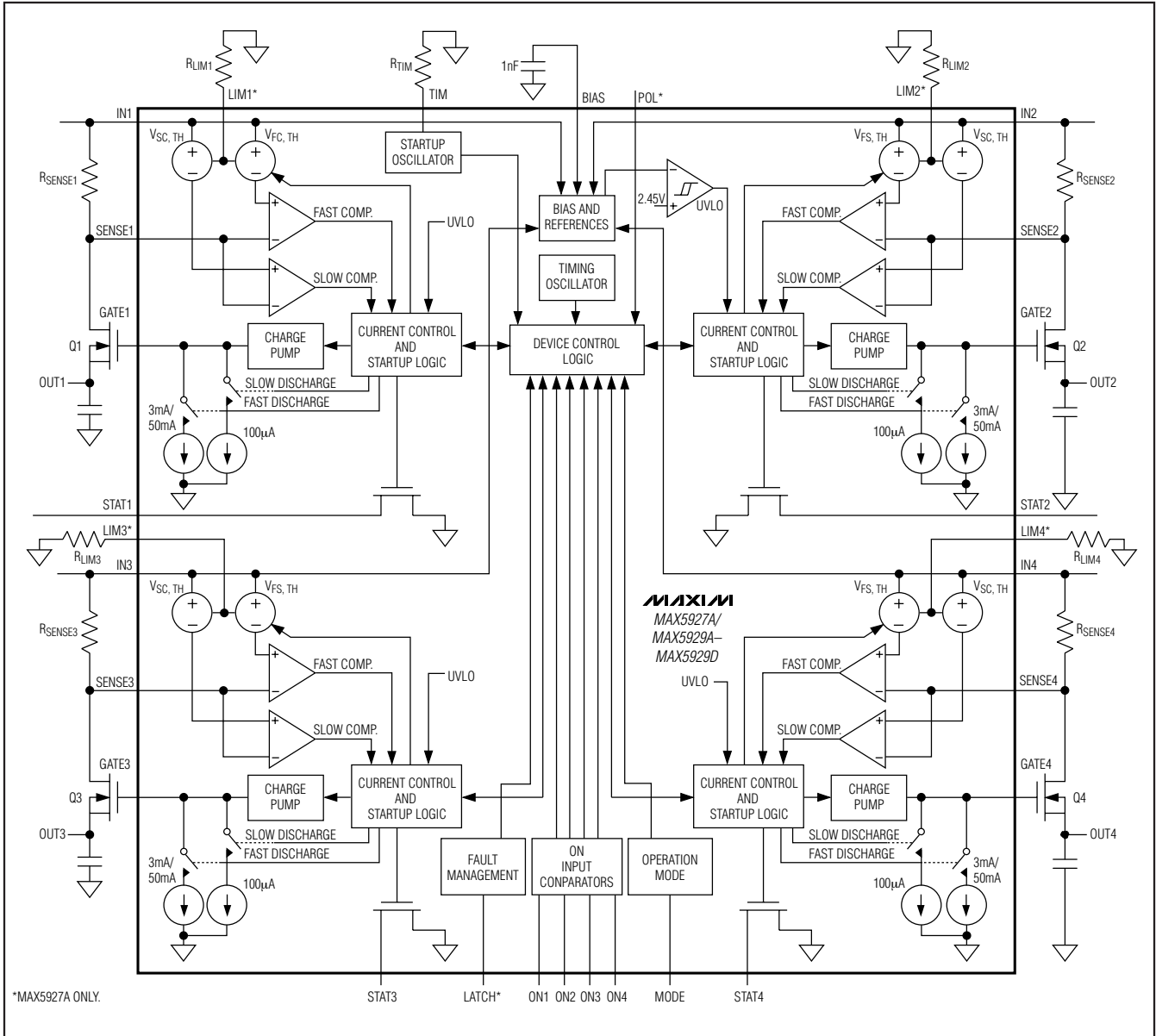

Figure 1. Functional Diagram

The MAX5927A/MAX5929A-MAX5929D turn off all channels if any of the above conditions are not met. After a fault-latched shutdown, cycle any of the ON_n inputs to unlatch and restart all channels.

Power-Sequencing Mode

Leave MODE floating to enter power-sequencing mode. While in power-sequencing mode, the MAX5927A/MAX5929A-MAX5929D turn on and off

each channel depending on the state of the corresponding V_{ONn}. To turn on a given channel:

- At least one V_{INn} must exceed V_{UVLO} (2.45V) for the UVLO to startup delay (37.5ms).
- All V_{INn} must exceed V_{PWRRDY} (0.95V).
- The corresponding V_{ONn} must exceed V_{ON,TH} (0.875V).
- No faults can be present on any channel.

Low-Voltage, Quad, Hot-Swap Controllers/Power Sequencers

MAX5927A/MAX5929A-MAX5929D

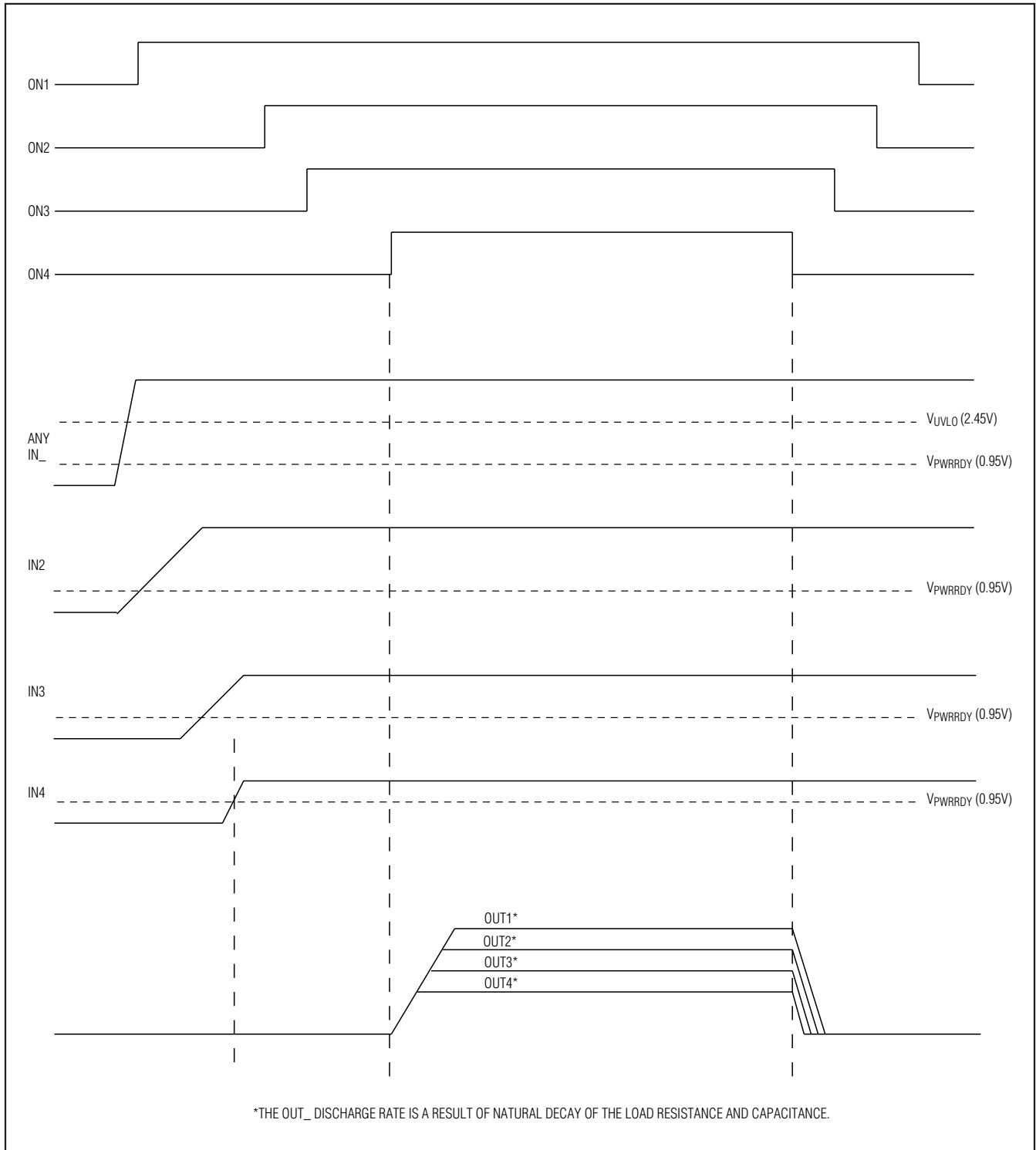

Figure 2. Voltage-Tracking Timing Diagram (Provided t_D , $UVLO$ Requirement is Met)

Low-Voltage, Quad, Hot-Swap Controllers/Power Sequencers

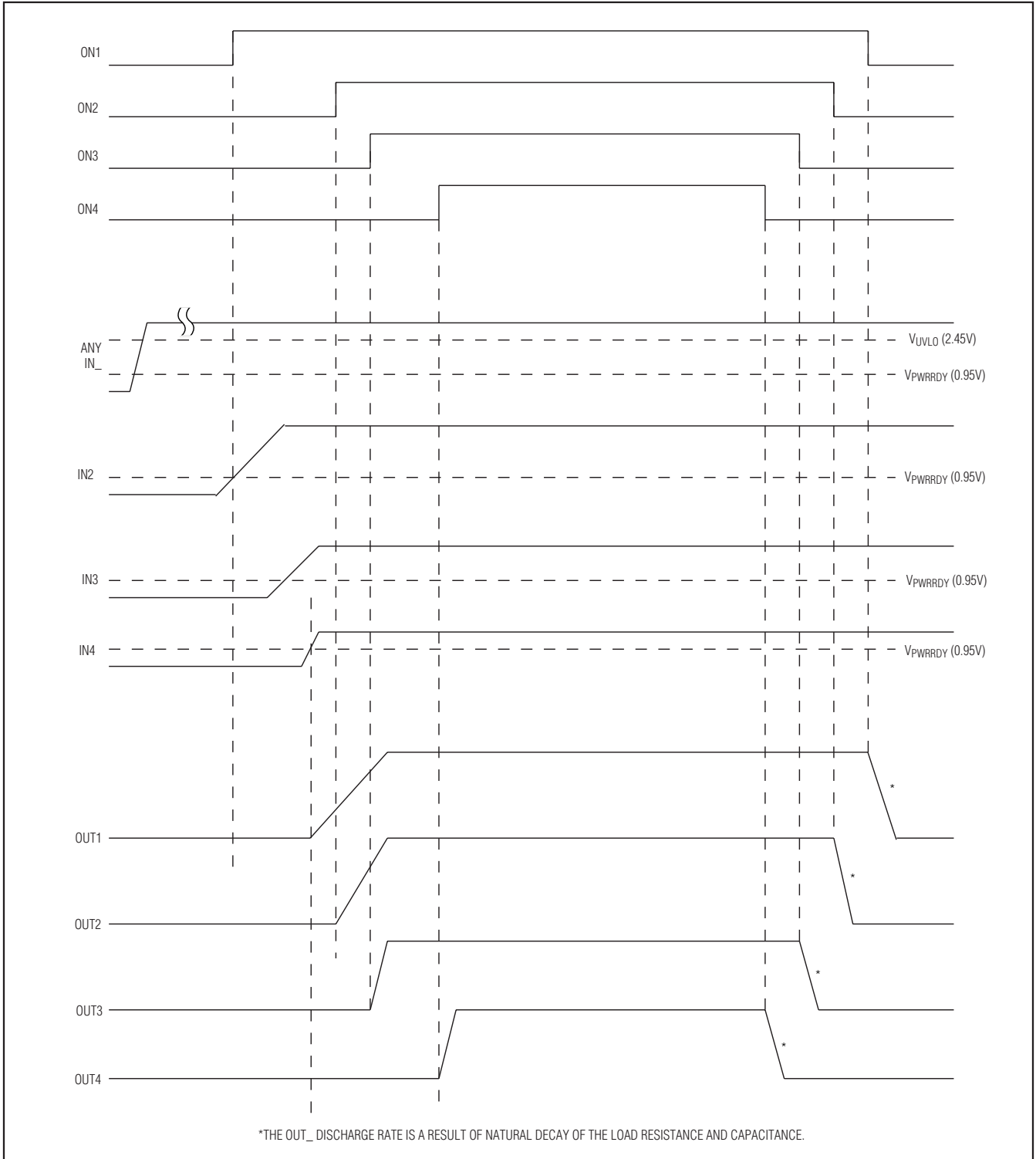

Figure 3. Power-Sequencing Timing Diagram (Provided t_D , UV_{LO} Requirement is Met)

Low-Voltage, Quad, Hot-Swap Controllers/Power Sequencers

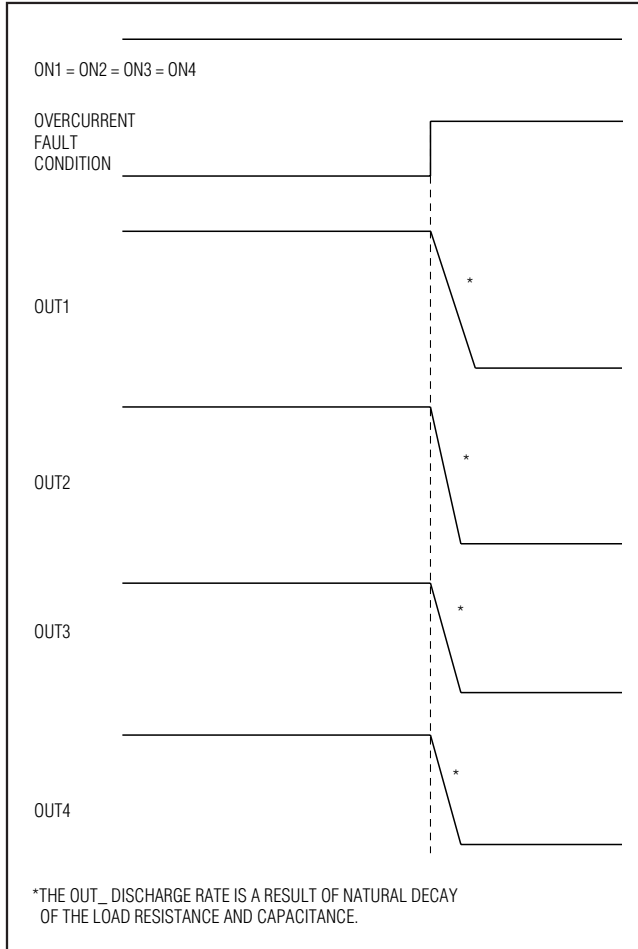

Figure 4. Power-Sequencing Fault Turn-Off

The MAX5927A/MAX5929A-MAX5929D turn off all channels if any of the above conditions are not met. After a fault-latched shutdown, cycle any of the ON_ inputs to unlatch and restart all channels, depending on the corresponding VON_ state.

Independent Mode

Connect MODE to GND to enter independent mode. While in independent mode, the MAX5927A/MAX5929A-MAX5929D provide complete independent control for each channel. To turn on a given channel:

- At least one VIN_ must exceed VUVLO (2.45V) for the UVLO to startup delay (37.5ms).
- The corresponding VIN_ must exceed VPWRRDY (0.95V).
- The corresponding VON_ must exceed VON,TH (0.875V).

The MAX5927A/MAX5929A-MAX5929D turn off the corresponding channel if any of the above conditions are not met. During a fault condition on a given channel only, the affected channel is disabled. After a fault-latched shutdown, recycle the corresponding ON_ inputs to unlatch and restart only the corresponding channel.

Startup Period

RTIM sets the duration of the startup period from 0.4ms (RTIM = 4kΩ) to 50ms (RTIM = 500kΩ) (see the *Setting the Startup Period, RTIM* section). The default startup period is fixed at 9ms when TIM is floating. The startup period begins after the turn-on conditions are met as described in the *Mode* section, and the device is not latched or in its autoretry delay (see the *Latched and Autoretry Fault Management* section).

The MAX5927A/MAX5929A-MAX5929D limit the load current if an overcurrent fault occurs during startup instead of completely turning off the external MOSFETs. The slow comparator is disabled during the startup period and the load current can be limited in two ways:

- 1) Slowly enhancing the MOSFETs by limiting the MOSFET gate-charging current.
- 2) Limiting the voltage across the external current-sense resistor.

During the startup period, the gate-drive current is limited to 100μA and decreases with the increase of the gate voltage (see the *Typical Operating Characteristics*). This allows the controller to slowly enhance the MOSFETs. If the fast comparator detects an overcurrent, the MAX5927A/MAX5929A-MAX5929D regulate the gate voltage to ensure that the voltage across the sense resistor does not exceed V_{SU,TH}. This effectively regulates the inrush current during startup.

Figure 6 shows the startup waveforms. STAT_ is asserted immediately after the startup period if no fault condition is present.

VariableSpeed/BiLevel Fault Protection

VariableSpeed/BiLevel fault protection incorporates comparators with different thresholds and response times to monitor the load current (Figure 7). During the startup period, protection is provided by limiting the load current. Protection is provided in normal operation (after the startup period has expired) by discharging the MOSFET gates with a 3mA/50mA pulldown current in response to a fault condition. After a fault, STAT_ is deasserted, the MAX5929A/MAX5929B stays latched off and the MAX5929C/MAX5929D automatically restart. Use the MAX5927A LATCH input to control whether the STAT_ outputs latch off or autoretry after a fault condition (see the *Latched and Autoretry Fault Management* section).

Low-Voltage, Quad, Hot-Swap Controllers/Power Sequencers

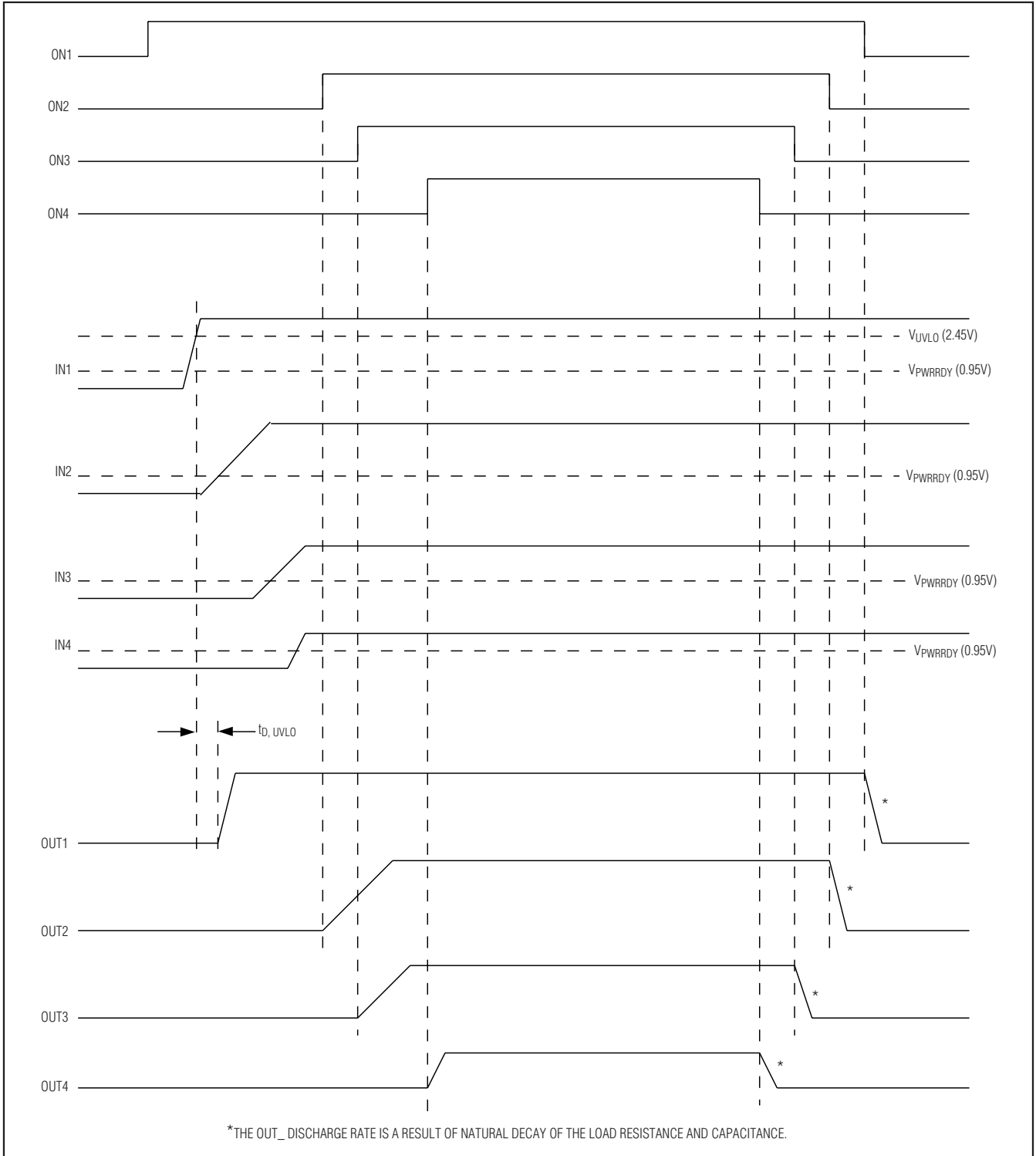

Figure 5. Independent Mode Timing Diagram

Low-Voltage, Quad, Hot-Swap Controllers/Power Sequencers

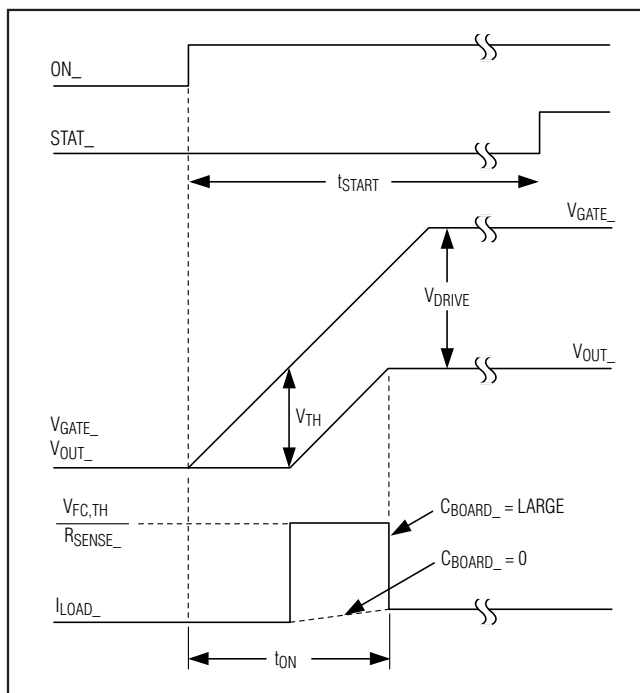

Figure 6. Independent Mode Startup Waveforms

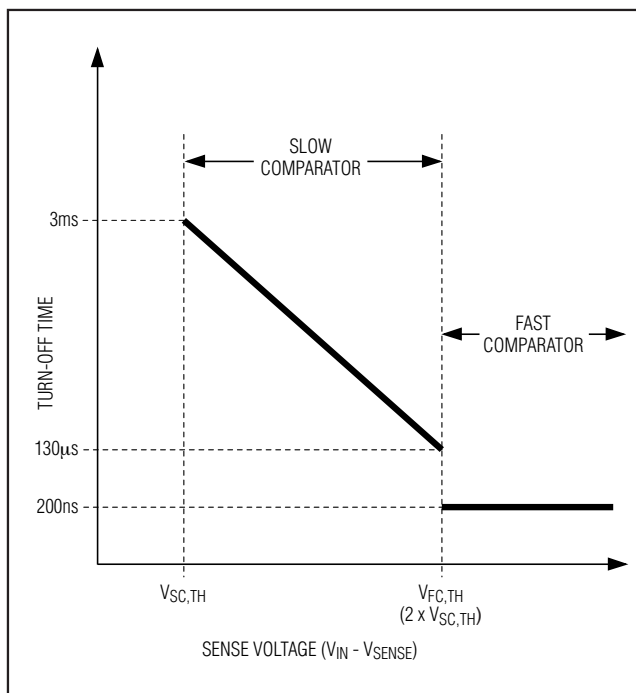

Figure 7. VariableSpeed/BiLevel Response

Slow-Comparator Startup Period

The slow comparator is disabled during the startup period while the external MOSFETs are turning on. Disabling the slow comparator allows the device to ignore the higher-than-normal inrush current charging the board capacitors when a card is first plugged into a live backplane.

Slow-Comparator Normal Operation

After the startup period is complete, the slow comparator is enabled and the device enters normal operation. The comparator threshold voltage ($V_{SC,TH}$) is adjustable from 25mV to 100mV. The slow-comparator response time is 3ms for a 1mV overdrive. The response time decreases to 100µs with a large overdrive. The variable-speed response time allows the MAX5927A/MAX5929A-MAX5929D to ignore low-amplitude momentary glitches, thus increasing system noise immunity. After an extended overcurrent condition, a fault is generated, STAT_ outputs are deasserted, and the MOSFET gates are discharged with a 3mA pulldown current.

Fast-Comparator Startup Period

During the startup period, the fast comparator regulates the gate voltages to ensure that the voltage

across the sense resistor does not exceed the startup fast-comparator threshold voltage ($V_{SU,TH}$). $V_{SU,TH}$ is scaled to two times the slow-comparator threshold ($V_{SC,TH}$).

Fast-Comparator Normal Operation

In normal operation, if the load current reaches the fast-comparator threshold, a fault is generated, STAT_ is deasserted, and the MOSFET gates are discharged with a strong 50mA pulldown current. This happens in the event of a serious current overload or a dead short. The fast-comparator threshold voltage ($V_{FC,TH}$) is scaled to two times the slow-comparator threshold ($V_{SC,TH}$). This comparator has a fast response time of 200ns (Figure 7).

Undervoltage Lockout (UVLO)

The UVLO prevents the MAX5927A/MAX5929A-MAX5929D from turning on the external MOSFETs until one input voltage exceeds the UVLO threshold (2.45V) for $t_{D,UVLO}$. The MAX5927A/MAX5929A-MAX5929D use power from the highest input voltage rail for the charge pumps. This allows for more efficient charge-pump operation. The highest $V_{IN_}$ is provided as an output at BIAS. The UVLO protects the external MOSFETs from an insufficient gate-drive voltage.

Low-Voltage, Quad, Hot-Swap Controllers/Power Sequencers

Table 2. Selecting Fault Management Mode (MAX5927A)

LATCH	FAULT MANAGEMENT
Unconnected	Fault condition latches MOSFETs off
Low	Autoretry mode

Table 3. Selecting STAT_ Polarity (MAX5927A)

POL	STAT_
Low	Asserts low
Unconnected	Asserts high (open drain)

$t_{D,UVLO}$ ensures that the board is fully inserted into the backplane and that the input voltages are stable. MAX5927A/MAX5929A-MAX5929D include a UVLO glitch filter, $t_{D,GF}$, to reject all input voltage noise and transients. Bringing all input supplies below the UVLO threshold for longer than $t_{D,GF}$ reinitiates $t_{D,UVLO}$ and the startup period, t_{START} . See Figure 8 for an example of automatic turn-on function.

Latched and Autoretry Fault Management

The MAX5929A/MAX5929B always latch the external MOSFETs off when an overcurrent fault is detected, and the MAX5929C/MAX5929D are always in autoretry mode. The MAX5927A can be configured to either latch the external MOSFETs off or to autoretry (see Table 2). Toggling ON_ below 0.875V for at least 100 μ s clears the MAX5929A/MAX5929B or MAX5927A (LATCH = unconnected) fault and reinitiates the startup period. Similarly, the MAX5929C/MAX5929D or MAX5927A (LATCH = GND) turn the external MOSFETs off when an overcurrent fault is detected, then automatically restart after the autoretry delay that is internally set to 64 times t_{START} .

Status Outputs (STAT_)

The status (STAT_) outputs are open-drain outputs that assert when hot swap is successful and t_{START} has elapsed. STAT_ deasserts if ON_ is low or if the channel is turned off for any fault condition.

The polarity of the STAT_ outputs is selected using POL for the MAX5927A (see Table 3). Tables 4 and 5 contain the MAX5927A/MAX5929A-MAX5929D truth tables.

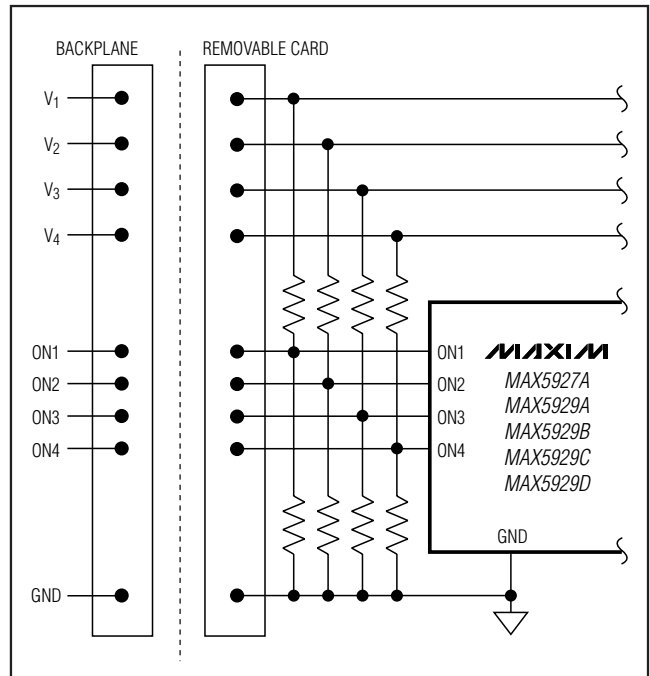

Figure 8. Automatic Turn-On when Input Voltages are Above their Respective Undervoltage Lockout Threshold (Provided $t_{D,UVLO}$ Requirement is Met)

Applications Information

Component Selection

n-Channel MOSFETs

Select the external MOSFETs according to the application's current levels. Table 6 lists recommended components. The MOSFET's on-resistance ($R_{DS(ON)}$) should be chosen low enough to have a minimum voltage drop at full load to limit the MOSFET power dissipation. High $R_{DS(ON)}$ causes output ripple if there is a pulsating load. Determine the device power rating to accommodate a short-circuit condition on the board at startup and when the device is in autoretry mode (see the *MOSFET Thermal Considerations* section).

Using these devices in latched mode allows the use of MOSFETs with lower power ratings. A MOSFET typically withstands single-shot pulses with higher dissipation than the specified package rating. Table 7 lists some recommended MOSFET manufacturers.

Low-Voltage, Quad, Hot-Swap Controllers/Power Sequencers

MAX5927A/MAX5929A-MAX5929D

Table 4. Status Output Truth Table: Voltage-Tracking and Power-Sequencing Modes

PART	CHANNEL 1 FAULT	CHANNEL 2 FAULT	CHANNEL 3 FAULT	CHANNEL 4 FAULT	STAT1/ GATE1*	STAT2/ GATE2*	STAT3/ GATE3*	STAT4/ GATE4*
MAX5927A (POL = 1), MAX5929B/ MAX5929D	Yes	X	X	X	L/OFF	L/OFF	L/OFF	L/OFF
	X	Yes	X	X	L/OFF	L/OFF	L/OFF	L/OFF
	X	X	Yes	X	L/OFF	L/OFF	L/OFF	L/OFF
	X	X	X	Yes	L/OFF	L/OFF	L/OFF	L/OFF
	No	No	No	No	H/ON	H/ON	H/ON	H/ON
MAX5927A (POL = 0), MAX5929C/ MAX5929D	Yes	X	X	X	H/OFF	H/OFF	H/OFF	H/OFF
	X	Yes	X	X	H/OFF	H/OFF	H/OFF	H/OFF
	X	X	Yes	X	H/OFF	H/OFF	H/OFF	H/OFF
	X	X	X	Yes	H/OFF	H/OFF	H/OFF	H/OFF
	No	No	No	No	L/ON	L/ON	L/ON	L/ON

*L = Low, H = High.

Table 5. Status Output Truth Table: Independent Mode

CHANNEL 1 FAULT	CHANNEL 2 FAULT	CHANNEL 3 FAULT	CHANNEL 4 FAULT	STAT1/ GATE1	STAT2/ GATE2	STAT3/ GATE3	STAT4/ GATE4
Yes	Yes	Yes	Yes	Unasserted/OFF	Unasserted/OFF	Unasserted/OFF	Unasserted/OFF
Yes	Yes	Yes	No	Unasserted/OFF	Unasserted/OFF	Unasserted/OFF	Asserted/ON
Yes	Yes	No	Yes	Unasserted/OFF	Unasserted/OFF	Asserted/ON	Unasserted/OFF
Yes	Yes	No	No	Unasserted/OFF	Unasserted/OFF	Asserted/ON	Asserted/ON
Yes	No	Yes	Yes	Unasserted/OFF	Asserted/ON	Unasserted/OFF	Unasserted/OFF
Yes	No	Yes	No	Unasserted/OFF	Asserted/ON	Unasserted/OFF	Asserted/ON
Yes	No	No	Yes	Unasserted/OFF	Asserted/ON	Asserted/ON	Unasserted/OFF
Yes	No	No	No	Unasserted/OFF	Asserted/ON	Asserted/ON	Asserted/ON
No	Yes	Yes	Yes	Asserted/ON	Unasserted/OFF	Unasserted/OFF	Unasserted/OFF
No	Yes	Yes	No	Asserted/ON	Unasserted/OFF	Unasserted/OFF	Asserted/ON
No	Yes	No	Yes	Asserted/ON	Unasserted/OFF	Asserted/ON	Unasserted/OFF
No	Yes	No	No	Asserted/ON	Unasserted/OFF	Asserted/ON	Asserted/ON
No	No	Yes	Yes	Asserted/ON	Asserted/ON	Unasserted/OFF	Unasserted/OFF
No	No	Yes	No	Asserted/ON	Asserted/ON	Unasserted/OFF	Asserted/ON
No	No	No	Yes	Asserted/ON	Asserted/ON	Asserted/ON	Unasserted/OFF
No	No	No	No	Asserted/ON	Asserted/ON	Asserted/ON	Asserted/ON

Note: STAT_n is asserted when hot swap is successful and t_{ON} has elapsed. STAT_n is unasserted during a fault.

Low-Voltage, Quad, Hot-Swap Controllers/Power Sequencers

Table 6. Recommended n-Channel MOSFETs

PART NUMBER	MANUFACTURER	DESCRIPTION
IRF7413	International Rectifier	11mΩ, 8-pin SO, 30V
IRF7401		22mΩ, 8-pin SO, 20V
IRL3502S		6mΩ, D ² PAK, 20V
MMSF3300	On Semiconductor	20mΩ, 8-pin SO, 30V
MMSF5N02H		30mΩ, 8-pin SO, 20V
MTB60N05H		14mΩ, D ² PAK, 50V
FDS6670A	Fairchild Semiconductor	10mΩ, 8-pin SO, 30V
ND8426A		13.5mΩ, 8-pin SO, 20V
FDB8030L		4.5mΩ, D ² PAK, 30V

Table 7. Component Manufacturers

COMPONENT	MANUFACTURER	PHONE	WEBSITE
Sense Resistors	Vishay/Dale Resistors	402-564-3131	www.vishay.com
	IRC, Inc.	361-992-7900	www.irctt.com
MOSFETs	International Rectifier	310-322-3331	www.irf.com
	Fairchild Semiconductor	888-522-5372	www.fairchildsemi.com
	On Semiconductor	602-244-6600	www.onsemi.com

Sense Resistor

The slow-comparator threshold voltage is adjustable from 25mV to 100mV. Select a sense resistor that causes a drop equal to the slow-comparator threshold voltage at a current level above the maximum normal operating current. Typically, set the overload current at 1.2 to 1.5 times the full load current. The fast-comparator threshold is two times the slow-comparator threshold in normal operating mode. Choose the sense resistor power rating to be greater than or equal to 2 x (OVERLOAD) x V_{SC,TH}. Table 7 lists some recommended sense resistor manufacturers.

Slow-Comparator Threshold, R_{LIM_} (MAX5927A)

The slow-comparator threshold voltage is adjustable from 25mV to 100mV, allowing designers to fine-tune the current-limit threshold for use with standard-value sense resistors. Low slow-comparator thresholds allow for increased efficiency by reducing the power dissipated by the sense resistor. Furthermore, the low 25mV slow-comparator threshold is beneficial when operating with supply rails down to 1V because it allows a small percentage of the overall output voltage to be used for current sensing. The VariableSpeed/BiLevel fault protection feature offers inherent system immunity against load transients and noise. This allows the slow-comparator threshold to be set close to the maximum normal

operating level without experiencing nuisance faults. To adjust the slow-comparator threshold, calculate R_{LIM_} as follows:

$$R_{LIM_} = \frac{V_{TH} - 25mV}{7.5\mu A}$$

where V_{TH} is the desired slow-comparator threshold voltage. Shorting LIM₋ to GND sets V_{TH} to 25mV. **Do not leave LIM₋ unconnected.**

Setting the Startup Period, R_{TIM}

The startup period (t_{START}) is adjustable from 0.4ms to 50ms. The adjustable startup period feature allows systems to be customized for MOSFET gate capacitance and board capacitance (C_{BOARD}). The startup period is adjusted with a resistor connected from TIM to GND (R_{TIM}). R_{TIM} must be between 4kΩ and 500kΩ. The startup period has a default value of 9ms when TIM is left unconnected. Calculate R_{TIM} with the following equation:

$$R_{TIM} = \frac{t_{START}}{128 \times 800pF}$$

where t_{START} is the desired startup period.

Low-Voltage, Quad, Hot-Swap Controllers/Power Sequencers

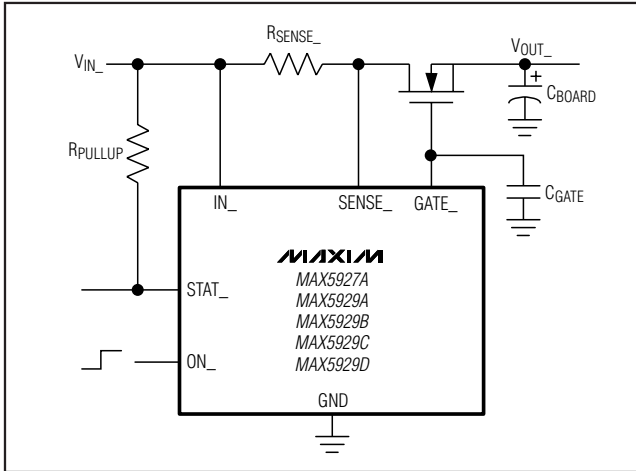

Figure 9. Operating with an External Gate Capacitor

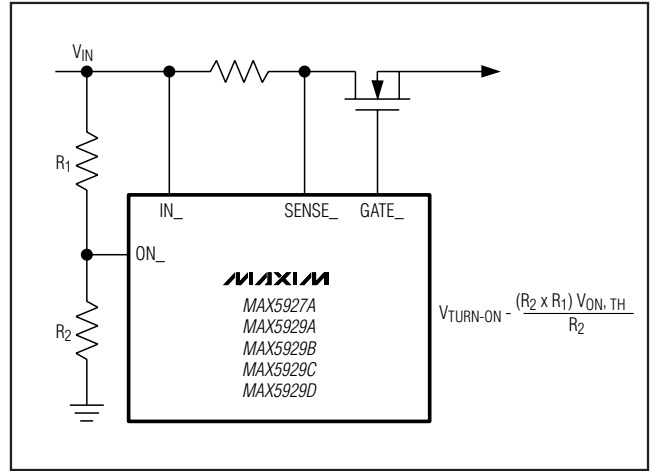

Figure 10. Adjustable Undervoltage Lockout

Startup Sequence

There are two ways of completing the startup sequence. **Case A** describes a startup sequence that slowly turns on the MOSFETs by limiting the gate charge. **Case B** uses the current-limiting feature and turns on the MOSFETs as fast as possible while still preventing a high inrush current. The output voltage ramp-up time (t_{ON}) is determined by the longer of the two timings, case A and case B. Set the startup timer (t_{START}) to be longer than t_{ON} to guarantee enough time for the output voltage to settle.

Case A: Slow Turn-On (Without Current Limit)

There are two ways to turn on the MOSFETs without reaching the fast-comparator current limit:

- If the board capacitance (C_{BOARD}) is small, the inrush current is low.
- If the gate capacitance is high, the MOSFETs turn on slowly.

In both cases, the turn-on time is determined only by the charge required to enhance the MOSFET. The small $100\mu\text{A}$ gate-charging current effectively limits the output voltage dv/dt . Connecting an external capacitor between GATE and GND extends the turn-on time. The time required to charge/discharge a MOSFET is as follows:

$$t = \frac{C_{GATE} \times \Delta V_{GATE} + Q_{GATE}}{I_{GATE}}$$

where:

C_{GATE} is the external gate to ground capacitance (Figure 9),

ΔV_{GATE} is the change in gate charge,

Q_{GATE} is the MOSFET total gate charge,

I_{GATE} is the gate-charging/discharging current.

In this case, the inrush current depends on the MOSFET gate-to-drain capacitance (C_{RSS}) plus any additional capacitance from GATE to GND (C_{GATE}), and on any load current (I_{LOAD}) present during the startup period.

$$I_{INRUSH} = \frac{C_{BOARD}}{C_{RSS} + C_{GATE}} \times I_{GATE} + I_{LOAD}$$

Example: Charging and discharging times using the Fairchild FDB7030L MOSFET

If $V_{IN1} = 5\text{V}$, GATE1 charges up to 10.4V ($V_{IN1} + V_{DRIVE}$), and therefore, $\Delta V_{GATE} = 10.4\text{V}$. The manufacturer's data sheet specifies that the FDB7030L has approximately 60nC of gate charge and $C_{RSS} = 600\text{pF}$. The MAX5927A/MAX5929A-MAX5929D have a $100\mu\text{A}$ gate-charging current and a $3\text{mA}/50\text{mA}$ normal/strong discharging current. $C_{BOARD} = 6\mu\text{F}$ and the load does not draw any current during the startup period. With no gate capacitor, the inrush current, charge, and discharge times are:

$$I_{INRUSH} = \frac{6\mu\text{F}}{600\text{pF} + 0} \times 100\mu\text{A} + 0 = 1\text{A}$$

$$t_{CHARGE} = \frac{0 \times 10.4\text{V} + 60\text{nC}}{100\mu\text{A}} = 0.6\text{ms}$$

$$t_{DISCHARGE} = \frac{0 \times 10.4\text{V} + 60\text{nC}}{3\text{mA}} = 0.02\text{ms}$$

$$t_{DISCHARGE(STRONG)} = \frac{0 \times 10.4\text{V} + 60\text{nC}}{50\text{mA}} = 1.2\mu\text{s}$$

Low-Voltage, Quad, Hot-Swap Controllers/Power Sequencers

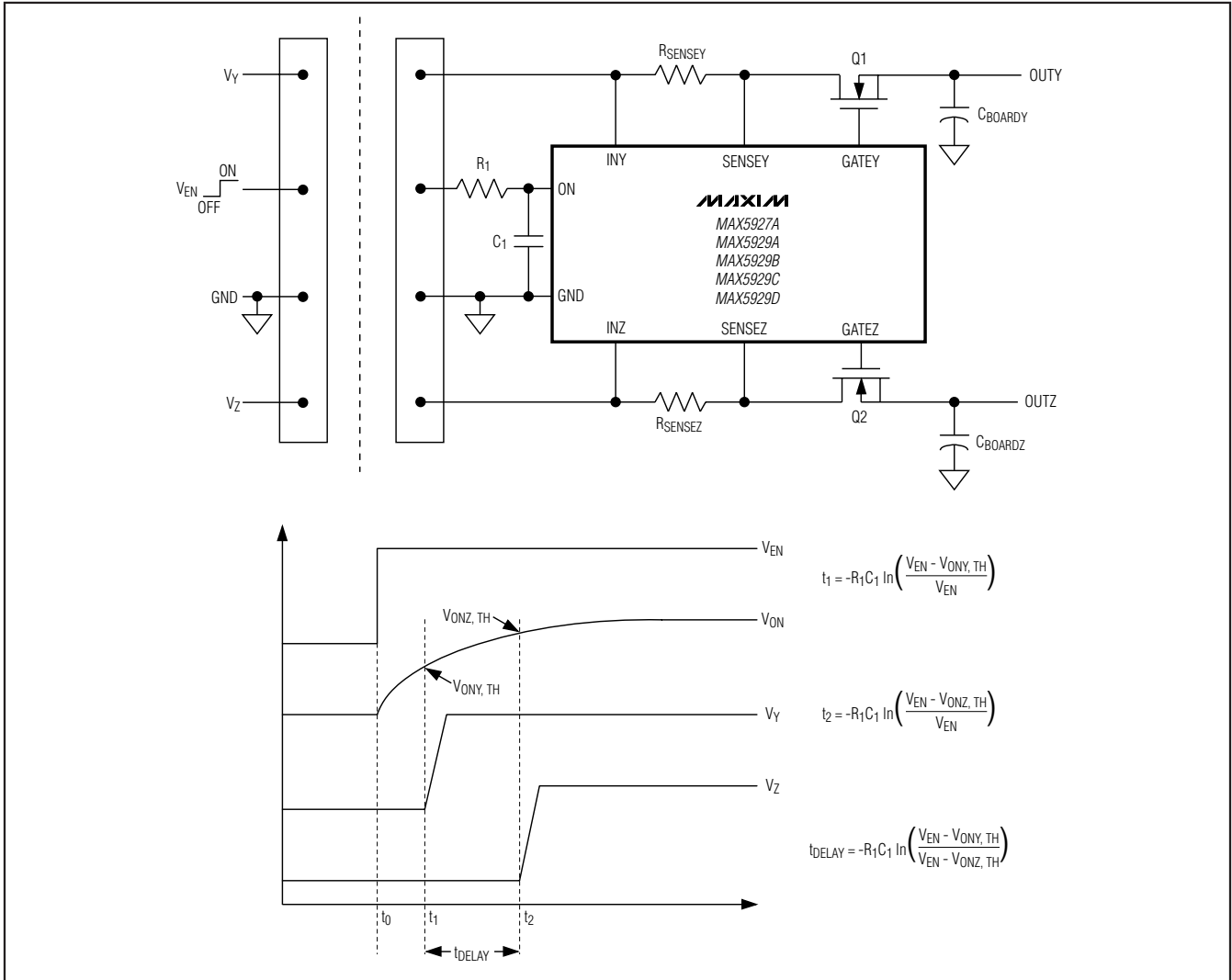

Figure 11. Power Sequencing: Channel Z Turns On t_{DELAY} After Channel Y

With a 22nF gate capacitor, the inrush current, charge, and discharge times are:

$$I_{INRUSH} = \frac{6\mu F}{600pF + 22nF} \times 100\mu A + 0 = 26.5mA$$

$$t_{CHARGE} = \frac{22nF \times 10.4V + 60nC}{100\mu A} = 2.89ms$$

$$t_{DISCHARGE} = \frac{22nF \times 10.4V + 60nC}{3mA} = 0.096ms$$

$$t_{DISCHARGE(STRONG)} = \frac{22nF \times 10.4V + 60nC}{50mA} = 5.8\mu s$$

Case B: Fast Turn-On (With Current Limit)

In applications where the board capacitance (C_{BOARD}) is high, the inrush current causes a voltage drop across R_{SENSE} that exceeds the startup fast-comparator threshold. The fast comparator regulates the voltage across the sense resistor to $V_{FC, TH}$. This effectively regulates the inrush current during startup. In this case, the current charging C_{BOARD} can be considered constant and the turn-on time is:

$$t_{ON} = \frac{C_{BOARD} \times V_{IN} \times R_{SENSE}}{V_{FC, TH}}$$

Low-Voltage, Quad, Hot-Swap Controllers/Power Sequencers

The maximum inrush current in this case is:

$$I_{\text{INRUSH}} = \frac{V_{\text{FC,TH}}}{R_{\text{SENSE}}}$$

Figure 6 shows the waveforms and timing diagrams for a startup transient with current regulation (see the *Typical Operating Characteristics*). **When operating under this condition, an external gate capacitor is not required.**

ON_ Comparators

The ON_ comparators control the on/off function of the MAX5927A/MAX5929A–MAX5929D. ON_ is also used to reset the fault latch (latch mode). Pull VON_ low for 100μs, tUNLATCH, to reset the shutdown latch. ON_ also programs the UVLO threshold (see Figure 10). A resistive-divider between VIN_, VON_, and GND sets the user programmable turn-on voltage. In power-sequencing mode, an RC circuit can be used at ON_ to set the delay timing (see Figure 11).

Using the MAX5927A/MAX5929A–MAX5929D on the Backplane

Using the MAX5927A/MAX5929A–MAX5929D on the backplane allows multiple cards with different input capacitance to be inserted into the same slot even if the card does not have on-board hot-swap protection. The startup period can be triggered if IN_ is connected to ON_ through a trace on the card (Figure 12).

Input Transients

The voltage at IN1, IN2, IN3, or IN4 must be above VUVLO during inrush and fault conditions. When a short-circuit condition occurs on the board, the fast comparator trips cause the external MOSFET gates to be discharged at 50mA according to the mode of operation (see the *Mode* section). The main system power supply must be able to sustain a temporary fault current, without dropping below the UVLO threshold of 2.45V, until the external MOSFET is completely off. If the main system power supply collapses below UVLO, the MAX5927A/MAX5929A–MAX5929D force the device to restart once the supply has recovered. The MOSFET is turned off in a very short time resulting in a high di/dt. The backplane delivering the power to the external card must have low inductance to minimize voltage transients caused by this high di/dt.

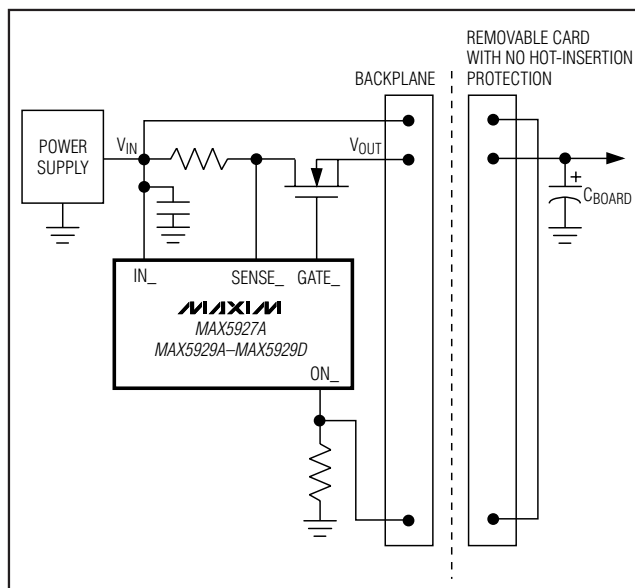

Figure 12. Using the MAX5927A/MAX5929A–MAX5929D on a Backplane

MOSFET Thermal Considerations

During normal operation, the external MOSFETs dissipate little power. The MOSFET $R_{\text{DS(ON)}}$ is low when the MOSFET is fully enhanced. The power dissipated in normal operation is $P_D = I_{\text{LOAD}}^2 \times R_{\text{DS(ON)}}$. The most power dissipation occurs during the turn-on and turn-off transients when the MOSFETs are in their linear regions. Take into consideration the worst-case scenario of a continuous short-circuit fault, consider these two cases:

- 1) The single turn-on with the device latched after a fault: MAX5927A (LATCH = high or unconnected) or MAX5929A/MAX5929B.
- 2) The continuous autoretry after a fault: MAX5927A (LATCH = low) or MAX5929C/MAX5929D.

MOSFET manufacturers typically include the package thermal resistance from junction to ambient ($R_{\theta\text{JA}}$) and thermal resistance from junction to case ($R_{\theta\text{JC}}$), which determines the startup time and the retry duty cycle ($d = t_{\text{START}} / (t_{\text{START}} + t_{\text{RETRY}})$). Calculate the required transient thermal resistance with the following equation:

$$Z_{\theta\text{JA(MAX)}} \leq \frac{T_{\text{JMAX}} - T_{\text{A}}}{I_{\text{START}} \times V_{\text{IN}}}$$

where $I_{\text{START}} = V_{\text{SU,TH}} / R_{\text{SENSE}}$.

Low-Voltage, Quad, Hot-Swap Controllers/Power Sequencers

Layout Considerations

To take full tracking advantage of the switch response time to an output fault condition, it is important to keep all traces as short as possible and to maximize the high-current trace dimensions to reduce the effect of undesirable parasitic inductance. Place the MAX5927A/MAX5929A-MAX5929D close to the card's connector. Use a ground plane to minimize impedance and inductance. Minimize the current-sense resistor trace length (<10mm), and ensure accurate current sensing with Kelvin connections (Figure 13).

When the output is short circuited, the voltage drop across the external MOSFET becomes large. Hence, the power dissipation across the switch increases, as does the die temperature. An efficient way to achieve good power dissipation on a surface-mount package is to lay out two copper pads directly under the MOSFET package on both sides of the board. Connect the two pads to the ground plane through vias, and use enlarged copper mounting pads on the topside of the board.

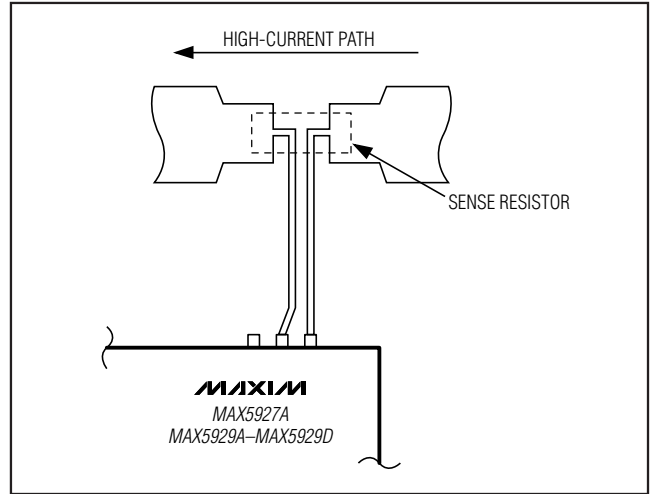
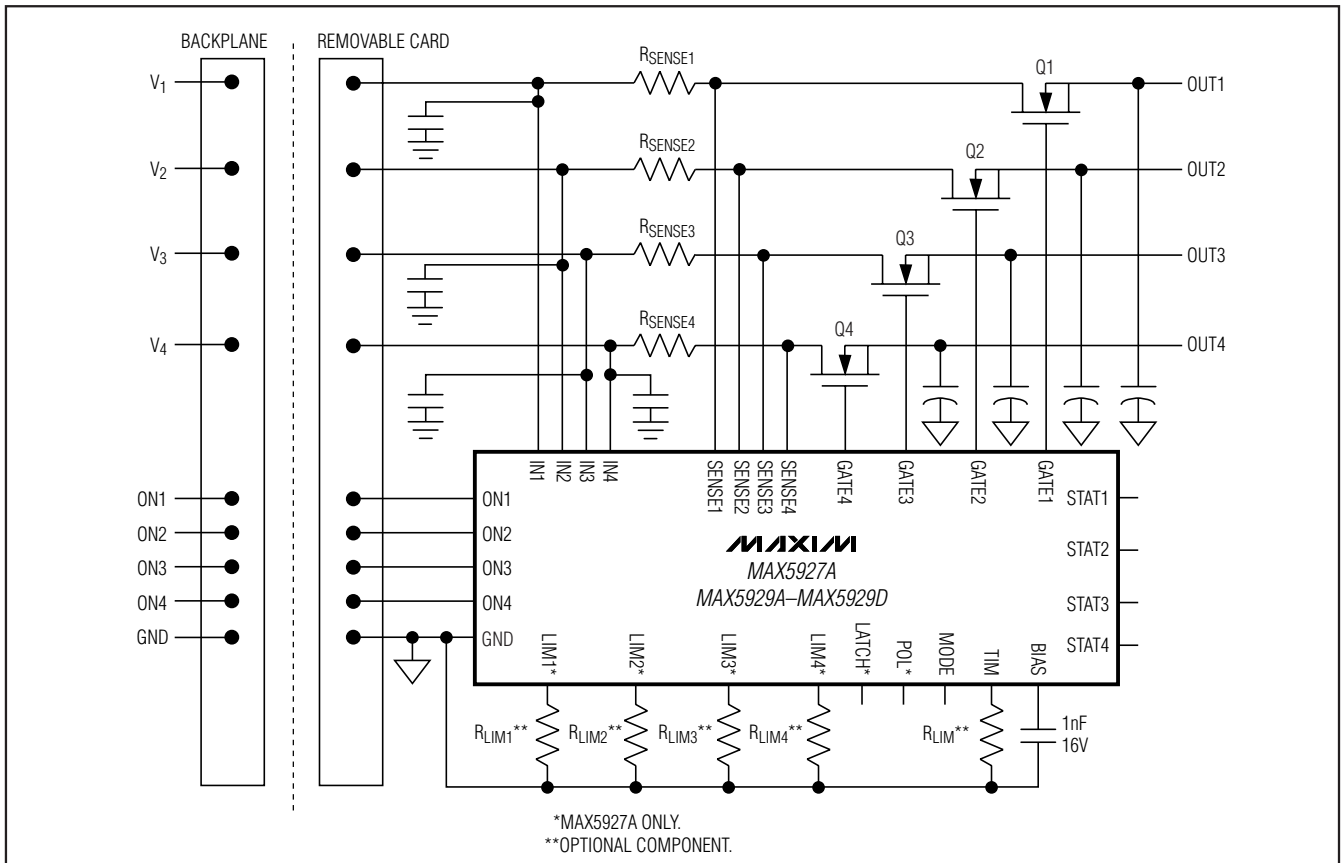

Figure 13. Kelvin Connection for the Current-Sense Resistors

Typical Operating Circuit



Low-Voltage, Quad, Hot-Swap Controllers/Power Sequencers

Selector Guide

PART	CURRENT LIMIT	FAULT MANAGEMENT	STAT_ POLARITY
MAX5927AETJ+	Programmable	Selectable	Selectable
MAX5929AEEG+	Fixed	Latched	Asserted high (open drain)
MAX5929BEEG+	Fixed	Latched	Asserted low
MAX5929CEEG+	Fixed	Autoretry	Asserted high (open drain)
MAX5929DEEG+	Fixed	Autoretry	Asserted low

Pin Configurations (continued)

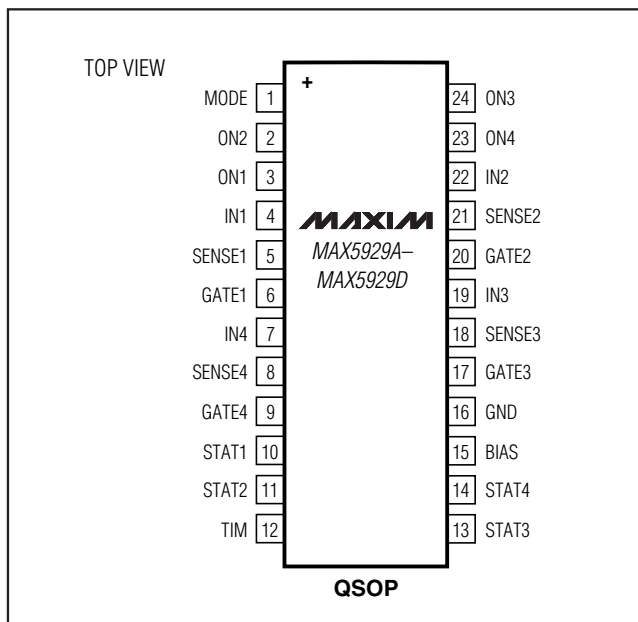

Chip Information

PROCESS: BiCMOS

Package Information

For the latest package outline information and land patterns, go to www.maxim-ic.com/packages.

PACKAGE TYPE	PACKAGE CODE	DOCUMENT NO.
24 QSOP	E24-1	21-0055
32 TQFN	T3255-4	21-0140

MAX5927A/MAX5929A-MAX5929D

Maxim cannot assume responsibility for use of any circuitry other than circuitry entirely embodied in a Maxim product. No circuit patent licenses are implied. Maxim reserves the right to change the circuitry and specifications without notice at any time.

Maxim Integrated Products, 120 San Gabriel Drive, Sunnyvale, CA 94086 408-737-7600 23



Компания «ЭлектроПласт» предлагает заключение долгосрочных отношений при поставках импортных электронных компонентов на взаимовыгодных условиях!

Наши преимущества:

- Оперативные поставки широкого спектра электронных компонентов отечественного и импортного производства напрямую от производителей и с крупнейших мировых складов;
- Поставка более 17-ти миллионов наименований электронных компонентов;
- Поставка сложных, дефицитных, либо снятых с производства позиций;
- Оперативные сроки поставки под заказ (от 5 рабочих дней);
- Экспресс доставка в любую точку России;
- Техническая поддержка проекта, помощь в подборе аналогов, поставка прототипов;
- Система менеджмента качества сертифицирована по Международному стандарту ISO 9001;
- Лицензия ФСБ на осуществление работ с использованием сведений, составляющих государственную тайну;
- Поставка специализированных компонентов (Xilinx, Altera, Analog Devices, Intersil, Interpoint, Microsemi, Aeroflex, Peregrine, Syfer, Eurofarad, Texas Instrument, Miteq, Cobham, E2V, MA-COM, Hittite, Mini-Circuits, General Dynamics и др.);

Помимо этого, одним из направлений компании «ЭлектроПласт» является направление «Источники питания». Мы предлагаем Вам помощь Конструкторского отдела:

- Подбор оптимального решения, техническое обоснование при выборе компонента;
- Подбор аналогов;
- Консультации по применению компонента;
- Поставка образцов и прототипов;
- Техническая поддержка проекта;
- Защита от снятия компонента с производства.



Как с нами связаться

Телефон: 8 (812) 309 58 32 (многоканальный)

Факс: 8 (812) 320-02-42

Электронная почта: org@eplast1.ru

Адрес: 198099, г. Санкт-Петербург, ул. Калинина, дом 2, корпус 4, литера А.