

LED Driver for Lighting Series

Electrolytic Capacitor Free
Buck Converter LED Driver

BD555A1AFV

● General Description

BD555A1AFV is a LED driver best for LED lighting applications. It supports dimming. Constant current switching controller for AC/DC buck converter is accumulated inside. By choosing external MOS Transistor, small~large power of LED can be driven. The driver is adoptable to a wide range of lighting from small light such as spotlights to large one like base lights. With digital power control, the average value of LED current is stably adjustable to requesting current. By only primary sense resistor, LED current is available to feedback LED current is useful without feedback circuits, reduce parts. Input characteristics and output characteristics is good by precisely digital power control.

It's support electrolytic free design by capacitor controller which is detect AC voltage and control ceramic capacitor.

● Features

- Highly efficient Buck AC/DC converter
- Primary control without feedback circuit
- High accuracy LED current output by LED average control
- Capacitor controller for Electrolytic free design
- Fixed switching frequency
- Built-in regulator for inner power supply
- Built-in LED open detection (shutdown type)
- Built-in UVLO detection
- Built-in thermal shut-down function

● Packages

SSOP-B14

5.00mm×6.40mm×1.15mm



● Key Specifications

- | | |
|--------------------------------|--------------------------|
| ■ AC Input range | 80 to 275V _{AC} |
| ■ Input Voltage range(AUX pin) | 10 to 38V |
| ■ Operating temperature | -40 to 100°C |
| ■ Accuracy of output current | ±1.5 % (Typ.) |

● Applications

- Spot light without dimming
- Desk lamp without dimming
- Down light without dimming
- Base light without dimming

● Typical Application Circuits

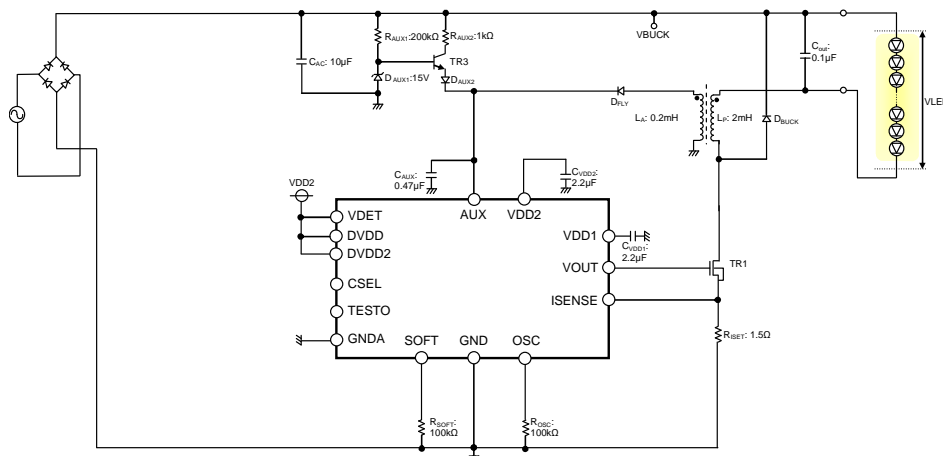

Fig.1 Typical Application Circuit

● Absolute Maximum Ratings (Ta=25°C)

Parameter	Symbol	Ratings	Unit	Conditions
Maximum Applied Voltage 1	VMAX1	4.5	V	VDD2, DVDD, DVDD2, OSC, SOFT, ISENSE PIN
Maximum Applied Voltage 2	VMAX2	15.5	V	VDET, VDD1, VOUT, CSEL, TESTO PIN
Maximum Applied Voltage 3	VMAX3	40.0	V	AUX PIN
Allowable Power Dissipation ^{*1}	Pd1	874.7	mW	
Operating Temperature	Topr	-40 ~ +100	°C	
Storage temperature	Tstg	-55 ~ +150	°C	

*1 When being mounted on 1 layer substrate(ROHM typical board).

Copper layer area is 20.2mm². When being used at over Ta=25°C, Pd1 decreases by about 7.00mW/°C.

● Recommended Operating Range (Ta=-40°C ~ +100°C)

Parameter	Symbol	Ratings			Unit	Conditions
		Min.	Typ.	Max.		
Operating supply voltage	AUX	10	16	38	V	

● Electrical Characteristics (Unless specified, AUX=16V, Ta = +25°C)

Parameter	Symbol	Ratings			Unit	Conditions
		Min.	Typ.	Max.		
[Circuit Current]						
Operating Current 1	Idd1	7.0	14.0	22.0	μA	At Start-up, AUX=7.0V
Operating Current 2	Idd2	1.5	2.5	3.5	mA	When stopping switching
[Regulator]						
VDD1 Voltage	VVDD1	11	12	13	V	With no-load
VDD1 Low Voltage Detection Voltage	Vuvlo1	4.0	5.0	6.0	V	When AUX is falling
VDD2 Voltage	VVDD2	2.9	3.3	3.7	V	With no-load
AUX Start-Up Voltage	Vstup	7.45	8.50	10.00	V	When AUX is rising
AUX Low Voltage Detection Voltage	Vuvloaux	6.00	6.50	7.45	V	When AUX is falling
[Switching Regulator]						
Oscillating Frequency	Fosc	90	100	110	kHz	Rosc=Open
Maximum Duty	Dmax	-	75.0	-	%	
Average Current Sense Voltage	Visns	475	500	525	mV	
Current Sense Blank-Time	Tisns _t	360	400	440	nsec	
VOUT High On-Resistance	Rvouth	3.0	7.0	16.0	Ω	IVOUT=20mA Source
VOUT Low On-Resistance	Rvoutl	2.0	4.5	12.0	Ω	IVOUT=20mA Sink
[Capacitor Controller]						
AC Input "H" Detection Voltage	Deth	340	420	500	mV	When VDET is rising
AC Input "L" Detection Voltage	Detl	240	300	360	mV	When VDET is falling
VDET Input Voltage Range	VVDET	-0.3	-	9.0	V	
CSEL On-Resistance	RonCS	-	10	100	Ω	ICSEL=2mA Sink
CSEL Off-Leakage	IleakCS	-	-	1.0	μA	CSEL=10V

● Pin Description

No	端子名称	I/O	機能	等価回路
1	DVDD	In	Digital Power Supply	C
2	VDET	In	AC voltage detection PIN(for Electrolytic free)	A
3	AUX	In	Power Supply Input Pin	A
4	VDD1	Out	Regulator Output 1 / Inner Power Supply 12.0V	C
5	VDD2	Out	Regulator Output 2 / Inner Power Supply 3.3V	C
6	OSC	In	Switching Frequency Setting Pin	C
7	DVDD2	In	Digital Power Supply	C
8	SOFT	In	Soft-start · Slope Time Setting Pin	C
9	VOUT	Out	Switching MOS Gate Driver Pin	D
10	ISENSE	In	Current Sense Pin	C
11	GND	-	GND Pin	B
12	GNDA	-	GND Pin	D
13	CSEL	Out	Capacitor Selector Pin(for Electrolytic free)	A
14	TESTO	Out	Test Output Pin	C

● Pin Configuration

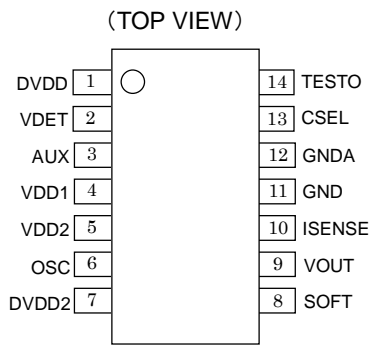

Fig.2 Pin Configuration

● Equivalent Circuit Diagram

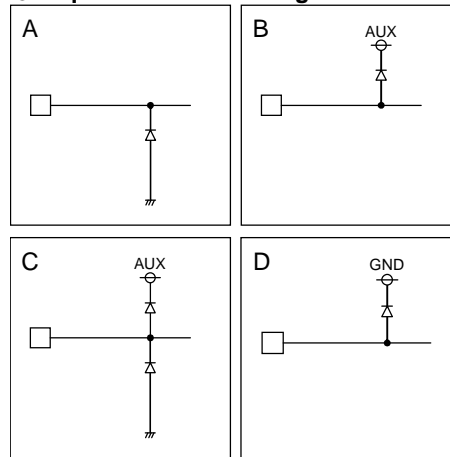

Fig.3 Equivalent Circuit Diagram

● Block Diagram

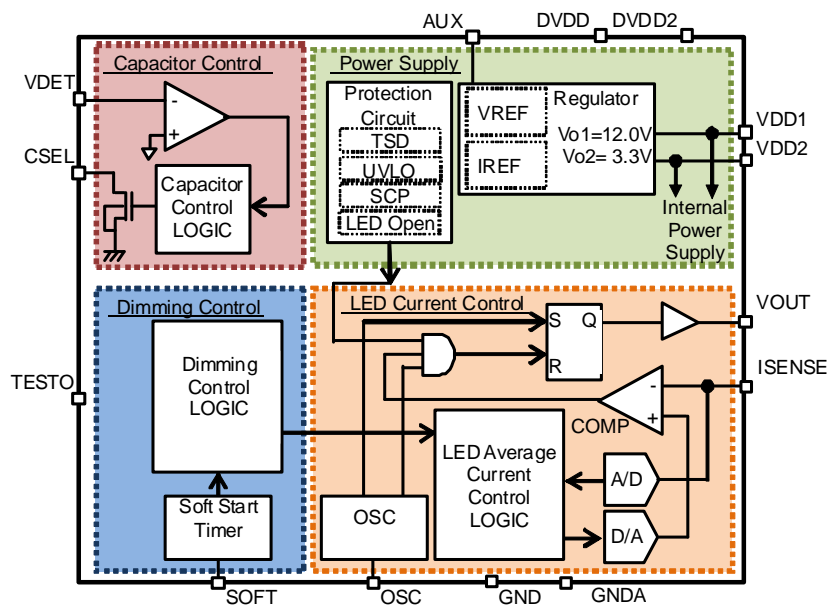

Fig.4 Block Diagram

●Description of Blocks

1) Regulator

Regulator with output of typ.3.3V is built in, which places AUX pin at input. When AC power source is input, according to clamp voltage of Zener Diode (D_{AUX}), power is supplied to AUX pin through start-up resistor (R_{AUX}). Until AUX pin gets typ.8.5V, switching operation is kept stopped. Circuit current is typ.10 μ A, so that voltage drop of R_{AUX} can be kept small. When AUX pin becomes typ.8.5V, switching operation starts. After the start of switching operation, it is recommended that power is supplied to AUX pin by fly-back method through transformer (L_{AUX}).

Output voltage of VDD2 is used at circuit inner power supply. When VDD2 pin becomes below typ.2.45V, UVLO detection is carried out and it leads to a non-operating state.

2) Soft Start

Soft start bring good effect which is smoothing light on at power on and prevent the LED short protection in power on, if output capacitor is big.

Soft start limits Duty of switching and increases the set value of LED peak current from low level by slope function.

Soft start is run only one time when the AC power is supplied. When VDD2 pin detect low voltage, this function is reset and run again when next AC power source is input (when low voltage detection is canceled).

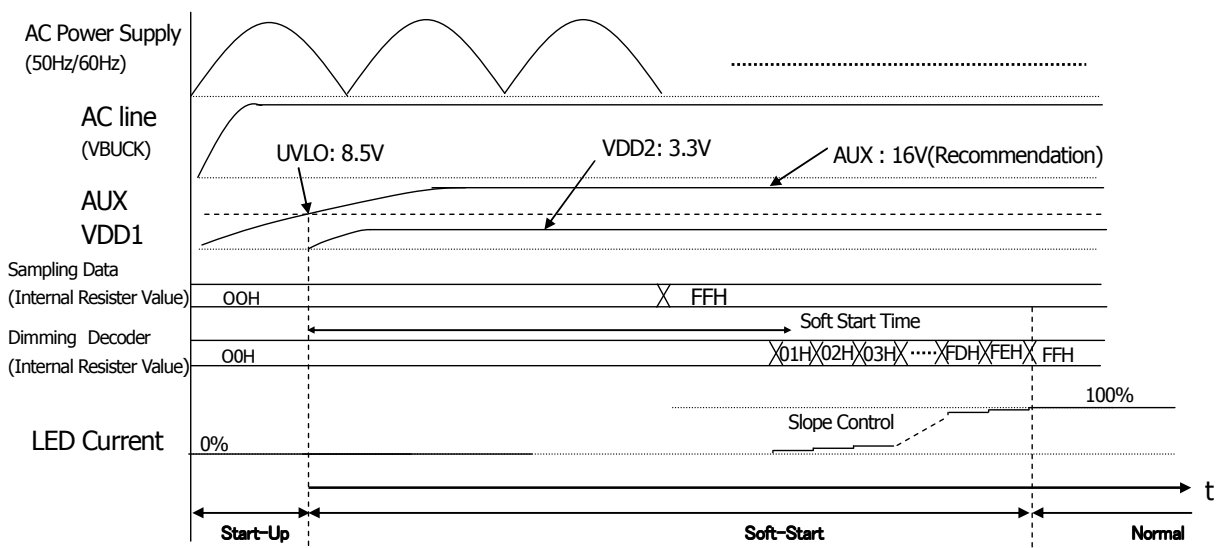

Fig.5 Soft Start

Soft start time can be set by resistor (R_{SOFT}) connecting to SOFT pin. Soft start time, T_{SOFT} is shown as in below chart.

R_{SOFT} , Setting of Soft-Start / Slope Time

R_{SOFT}	Soft-Start / Slope Time
100k Ω	100msec
39k Ω	800msec
24k Ω	1600msec
No Connection	0msec (No Slope)

3) Digitally Controlled Switching Converter

• Operation Description of Buck Converter

When AUX becomes typ.8.5V, switching controller starts its switching operation. Switching frequency is determined depending on the value of resistor (R_{OSC}) connecting to OSC pin.

At the beginning of switching cycle, FET (TR1) for switching turns ON. Coil current flows into R_{ISET} and current is detected by ISENSE pin. However even TR1 turns ON, current detection is not carried out for a definite period of time, typ.400nsec. It prevents a malfunction caused by reverse recovery current of freewheel diode (D_{OUT}), when TR1 turns ON. TR1 turns OFF, so that the voltage of ISENSE pin increases linearly and LED average current is adjusted to requested current.

Switching duty(D) is generally shown as below formula, considering input voltage as V_{BUCK} and output voltage as V_{LED}.

$$D = \frac{V_{LED}}{V_{BUCK}}$$

When switching duty (D) reaches to maximum 75.0% (typ.), the status is forced to change into OFF. Moreover minimum On width is 400nsec (typ.). For 400nsec, ON status is maintained compulsorily.

• Setting of LED Current

Switching controller adjusts the average current of coil to a value which is set by R_{ISET}, monitoring coil current at switching "ON" from ISENSE pin. Since the average current of coil and LED current are of equivalent value, setting of LED current is determined by controlling the average current of coil.

LED average current, I_{AVE} is determined by ripple current ΔI_L of coil. Peak Current is shown as below formula in continuous current mode (CCM).

Compute ΔI_L from the data sampled with A/D converter from ISENSE pin, and calculate peak current I_{PEAK}, so that average current becomes requested value.

Input peak current I_{PEAK} into D/A converter and treat it as reference voltage of comparator COMP.

Since ΔI_L is calculated and feed-backed, average current control is available without influence of input voltage • output voltage • constant of coil • switching frequency which are change by ΔI_L.

$$I_{AVE} = I_{PEAK} - \frac{\Delta I_L}{2}$$

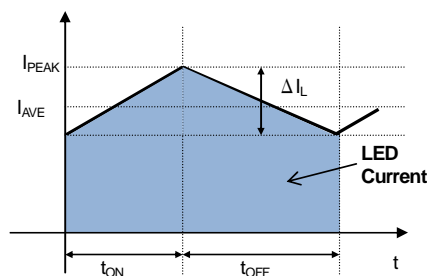

Fig.6 Waveform of LED Current (in continuous current mode)

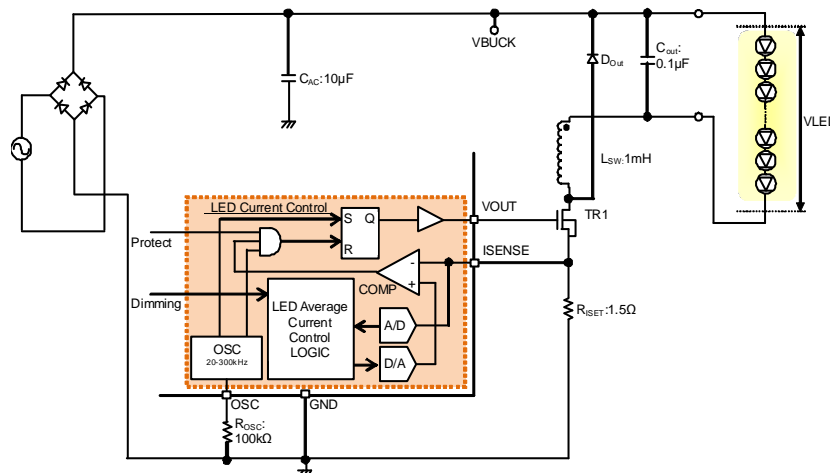

Fig.7 Block Diagram of Average Current Control

LED Average Current I_{AVE} is set by resistor (R_{ISET}) connecting ISENSE pin. Each set-up current is indicated as below formula. Setting current is chosen drive current of external MOS FET. Average current sense voltage, V_{ISNS} is set to 500mV.

$$I_{AVE} = \frac{V_{ISNS}}{R_{ISET}}$$

R_{ISET} , Set-Up Examples of LED Average Current

R_{ISET}	LED Average Current
5.10 Ω	98mA
2.00 Ω	250mA
1.50 Ω	333mA
1.00 Ω	500mA
0.75 Ω	667mA
0.68 Ω	735mA

Fig.8 shows input voltage characteristics when R_{ISET} is 1 Ω . And Fig.9 indicates output voltage characteristics.

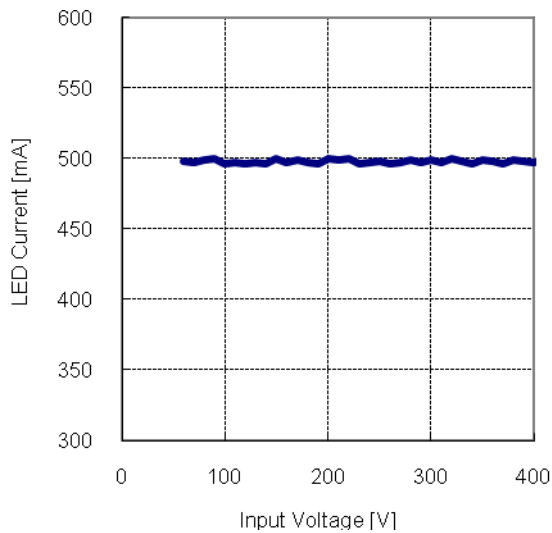

Fig.8 Input voltage (VPRI) vs. LED Current

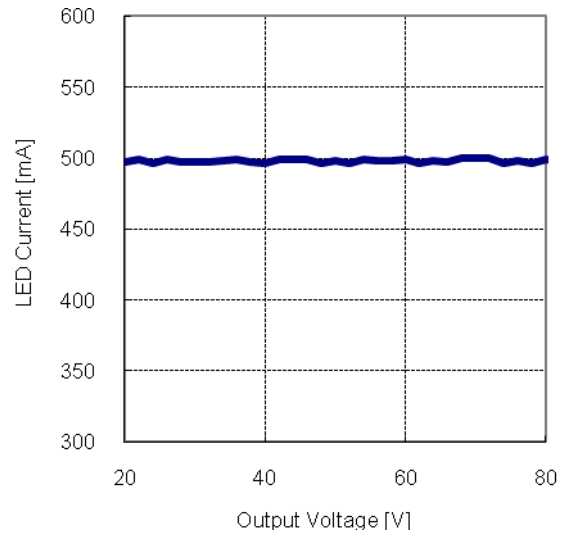

Fig.9 Output voltage (VLED) vs. LED Current

Under the following conditions, it is difficult to control average current.

- 1.) When On time is 400nsec.

On Time, t_{ON} , is indicated as follows, considering switching frequency as f_{SW} .

$$t_{ON} = \left(\frac{V_{LED}}{V_{BUCK}} \right) \times \frac{1}{f_{SW}}$$

When input voltage is high, output voltage is low or switching frequency is high, there is a possibility that on time becomes 400nsec.

Switching frequency is recommended to be set low.

- 2.) When switching duty (D) is 75.0%.

Switching duty (D) is expressed as follows.

$$D = \frac{V_{LED}}{V_{BUCK}}$$

When input voltage is low or output voltage is high, there is a possibility switching duty (D) exceeds 75.0%.

It is necessary to keep input voltage high or make output voltage low.

3.) In case of DCM (discontinuous current mode)

In CCM, digitally controlled switching converter carries out average current control. In DCM, since current of section where no current flows cannot be controlled, LED current value becomes lower than set-up current value.

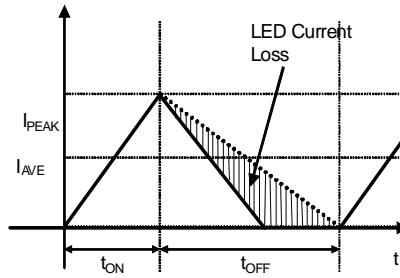

Fig.10 Waveform of LED Current (In discontinuous current mode)

DCM occurs when LED set-up current is low or switching frequency is low. Switching frequency is recommended to set high.

• **Setting of Switching Frequency**

In setting of switching frequency, a relation of trade-off holds between power efficiency and the size (price) of external components. To improve power efficiency, slower switching frequency is better but in that case, the size of external parts get bigger.

Maximum switching frequency is decided by minimum ON time.

Minimum ON time ($t_{ON(MIN)}$) is available when input voltage V_{BUCK} is highest voltage and output voltage V_{LED} is minimum., It is shown as below formula.

$$t_{ON(MIN)} = \left(\frac{V_{LED(MIN)}}{V_{BUCK(MAX)}} \right) \times \frac{1}{f_{SW}}$$

Switching duty (D) is simply shown as following formula.

$$D = \frac{V_{LED}}{V_{BUCK}} = t_{ON} \times f_{SW}$$

f_{SW} : Switching Frequency

Set switching frequency within 20kHz~300kHz. Determine it so that minimum ON time ($t_{ON(MIN)}$) gets more than 400nsec.

Switching frequency f_{OSC} is determined by resistor R_{OSC} connecting to OSC pin.

Each set-up frequency is indicated as below formula. However if R_{osc} is not connected, it is set to 100 kHz. Moreover if R_{osc} is short-circuit to GND, it is set to 20kHz.

$$f_{OSC} [kHz] = 8192 / R_{osc} [k\Omega]$$

R_{OSC} Setting Example of Switching Frequency

R_{OSC}	Switching Frequency
300 k Ω	28kHz
150 k Ω	50kHz
68 k Ω	120kHz
27 k Ω	300kHz
No Connection	100kHz

● Protection Function

1) Detection of Abnormal Temperature

Thermal shut down starts to operate over 150°C(typ.), making IC from active status to non-active status. In the non-active status, switching operation stops. Gate driver output turns into low impedance against GND.

When the temperature of IC returns to normal level, IC recovers from initial mode to active mode.

2) VDD1 Low Voltage Detection

When VDD1 power supply voltage is low or any abnormal status occurs such as VDD1 pin short, IC is turned to non-active status from active mode, since there is a possibility that IC does not operate properly. In non-active mode, switching operation stops. Gate driver output turns into low impedance against GND.

When VDD1 power supply voltage returns to normal level, IC recovers from initial mode to active mode.

3) VDD2 Low Voltage Detection

When VDD2 power supply voltage is low or any abnormal problem occurs such as VDD2 pin short, IC is turned to non-active mode, since there is a possibility that IC does not operate properly. In non-active mode, switching operation stops. Gate driver output turns into low impedance against GND.

When VDD2 power supply voltage returns to normal level, IC recovers from initial mode to active mode.

4) AUX Low Voltage Detection

When AUX power supply voltage is low or any abnormal problem occurs such as AUX pin short, IC is turned non-active, since there is a possibility that IC does not operate properly. In non-active mode, switching operation stops. Gate driver output turns into low impedance against GND.

When AUX power supply voltage returns to normal level, IC recovers from initial mode to active mode.

5) LED OPEN Detection

IC is turned from active mode to non-active mode, when ISENSE pin voltage does not reach to average current value for 52.4msec because of LED's OPEN defects, OPEN ISENSE pin, coil's OPEN defects and so on. In non-active mode, switching operation stops. Gate driver output turns into low impedance against GND.

LED OPEN detection holds non-active mode until VDD2 low voltage detection is carried out. IC recovers to active mode in following flow; switching operation stops → VDD2 low voltage detection works → LEDOPEN detection is re-set.

6) LED GND SHORT Detection

IC is turned from active mode to non-active mode, when ISENSE pin voltage does not reach to average current value for 52.4msec because of LED's GND SHORT defects, SHORT ISENSE pin. In non-active mode, switching operation stops. Gate driver output turns into low impedance against GND.

LED OPEN detection holds non-active mode until VDD2 low voltage detection is carried out. IC recovers to active mode in following flow; switching operation stops → VDD2 low voltage detection works → LED GND SHORT detection is re-set.

● Typical Performance Curves

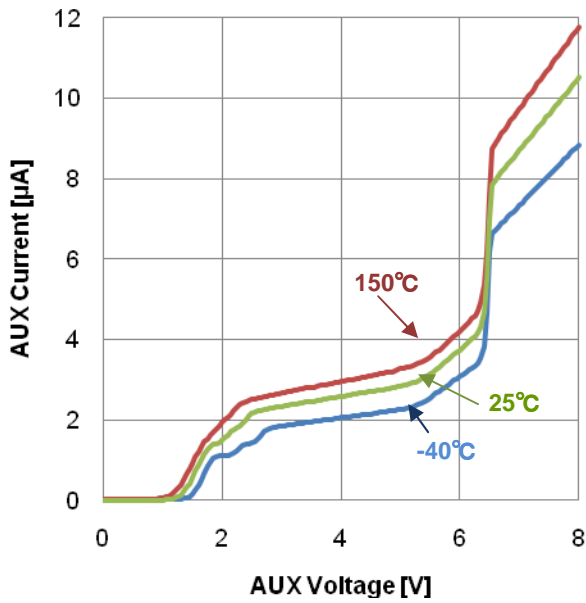

Fig.11 Current Consumption1

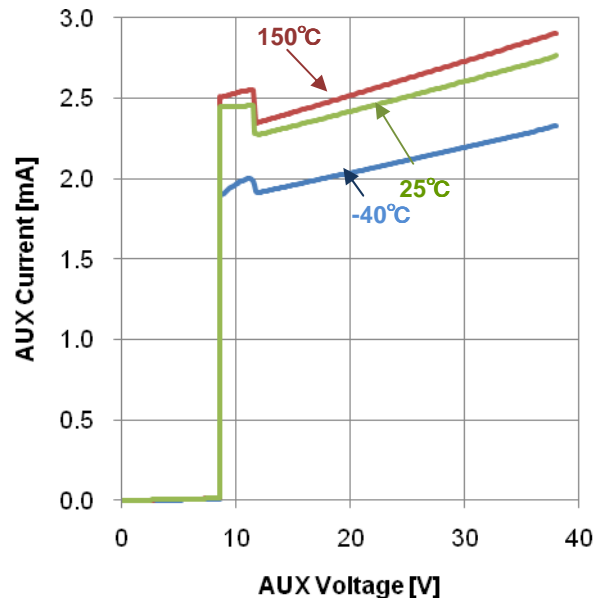

Fig.12 Current Consumption.2

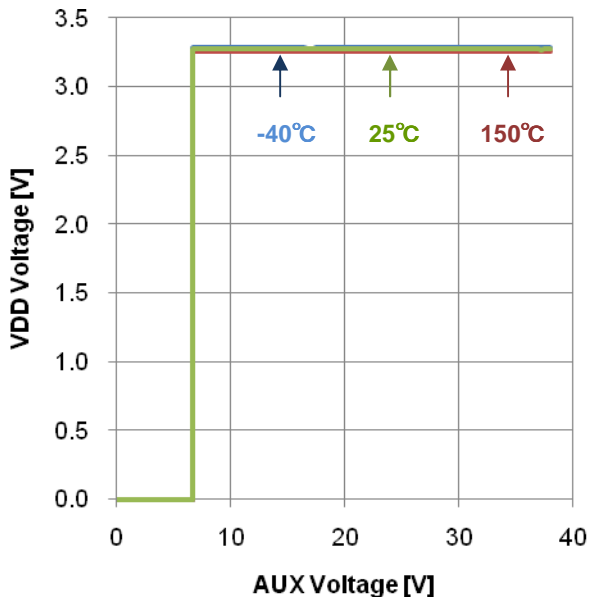

Fig.13 VDD2 Voltage

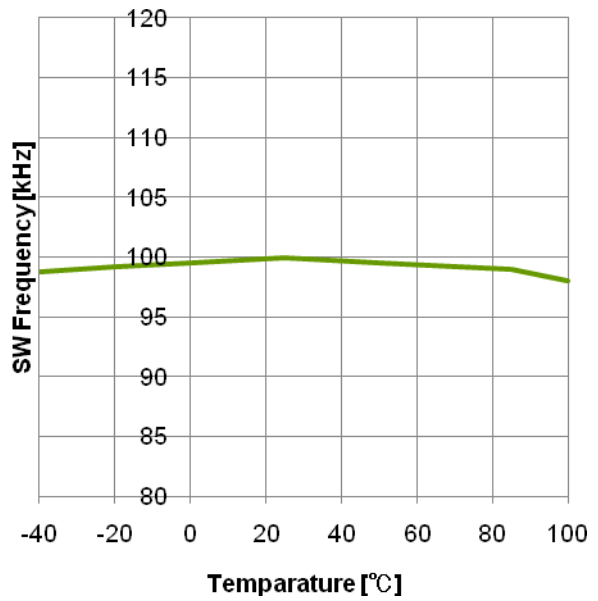

Fig.14 Switching Frequency

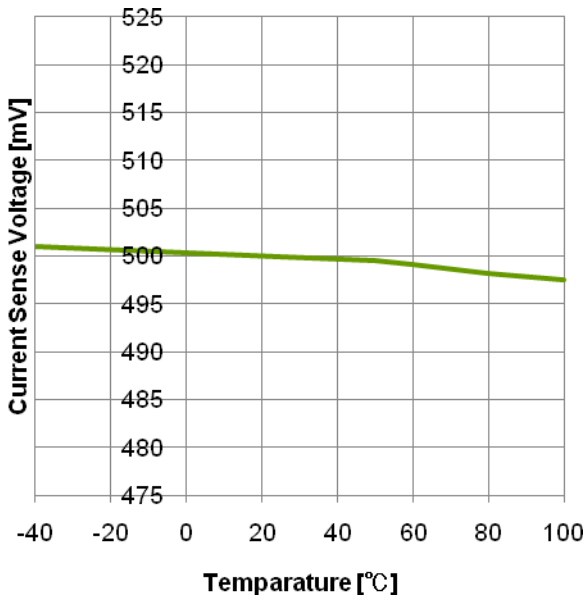

Fig.15 Average Current Sense Voltage

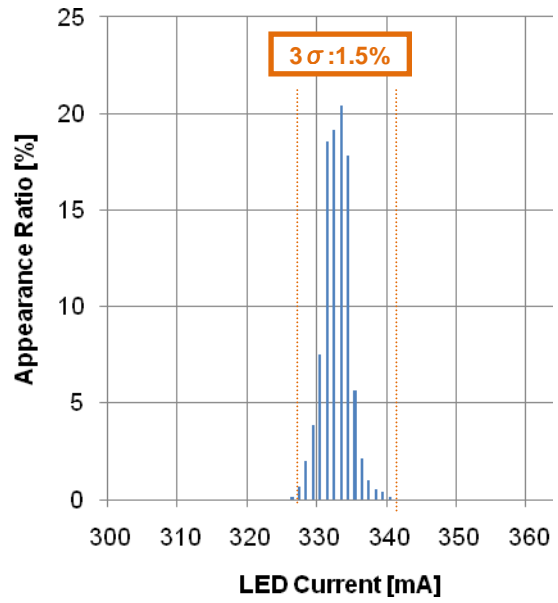

Fig.16 LED Current accuracy

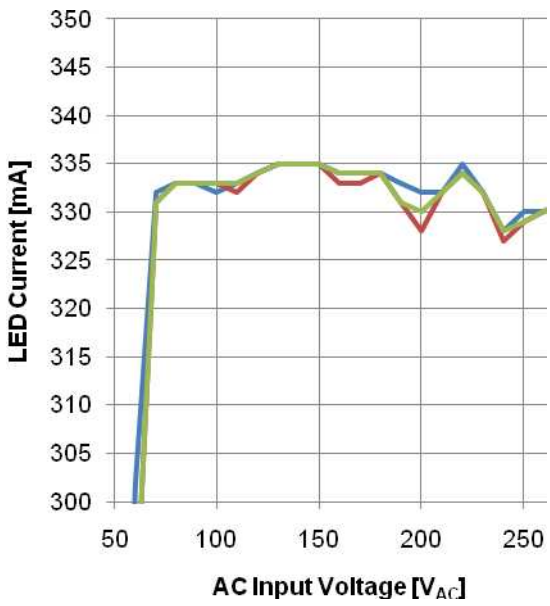

Fig.17 AC Input Voltage Characteristics

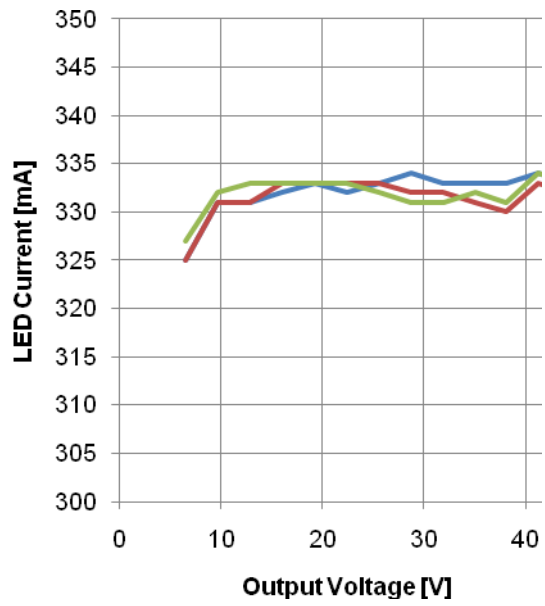

Fig.18 Output voltage Characteristics

●Application Examples

1) Basic Circuit (Buck)

Connect about LEDs in series. Connect 1.5Ω resistor to R_{ISET} and set LED average current to 333mA. Select external MOS-FET depending on LED current. (recommendation : R5205CND:ROHM)
 Set AUX power supply to over 12.0V. At start up, power is supplied through TR3. When AUX exceeds start-up voltage 8.5V, switching operation starts. In switching operation, power is supplied via transformer.

Connect VDET pin to VDD2. Connect DVDD and DVDD2 to VDD2, too. Switching frequency is set by connecting resistor between OSC pin and GND. Slope time of dimming can be set by connecting resistor between SOFT pin and GND.

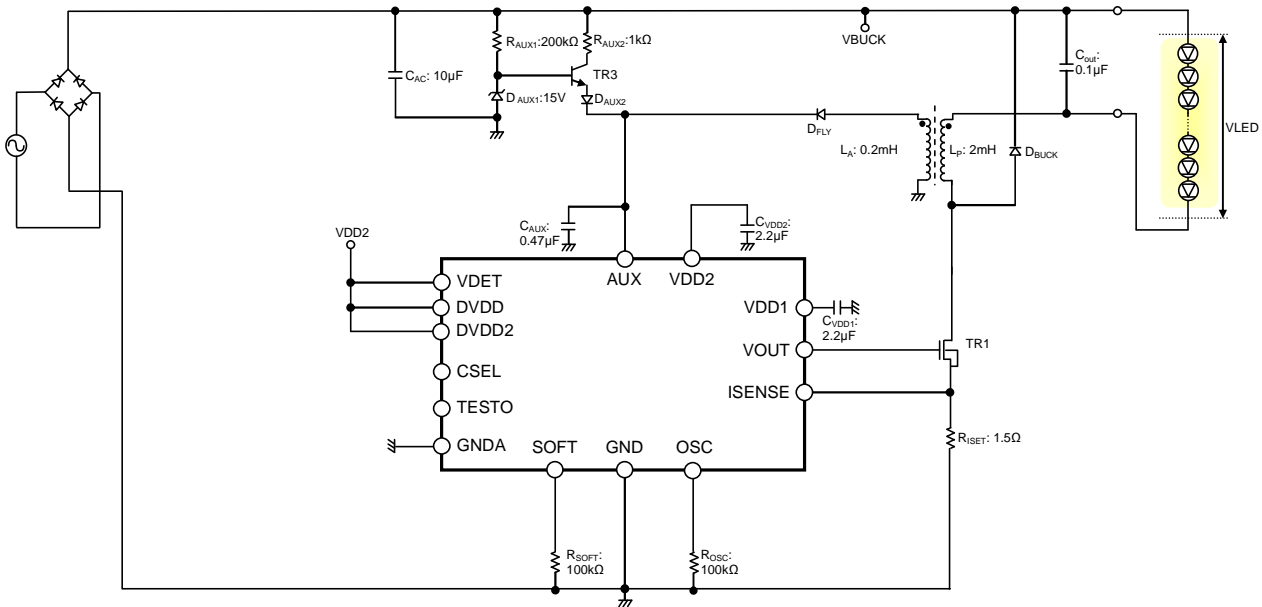

Fig.19 Application Example (High-Power LED 333mA)

2) Design for more compact circuit, reducing number of components

Supply power through R_{AUX}. When AUX exceeds start-up voltage, 8.5V, switching operation starts. In steady state, set AUX voltage to over 12V. Since about 3mA power loss (0.3W: at AC100V) occurs at R_{AUX}, efficiency gets worse compared to the basic circuit.

Make OSC and SOFT pins Open. At this time, switching frequency becomes 100kHz and SOFT time is 0msec.

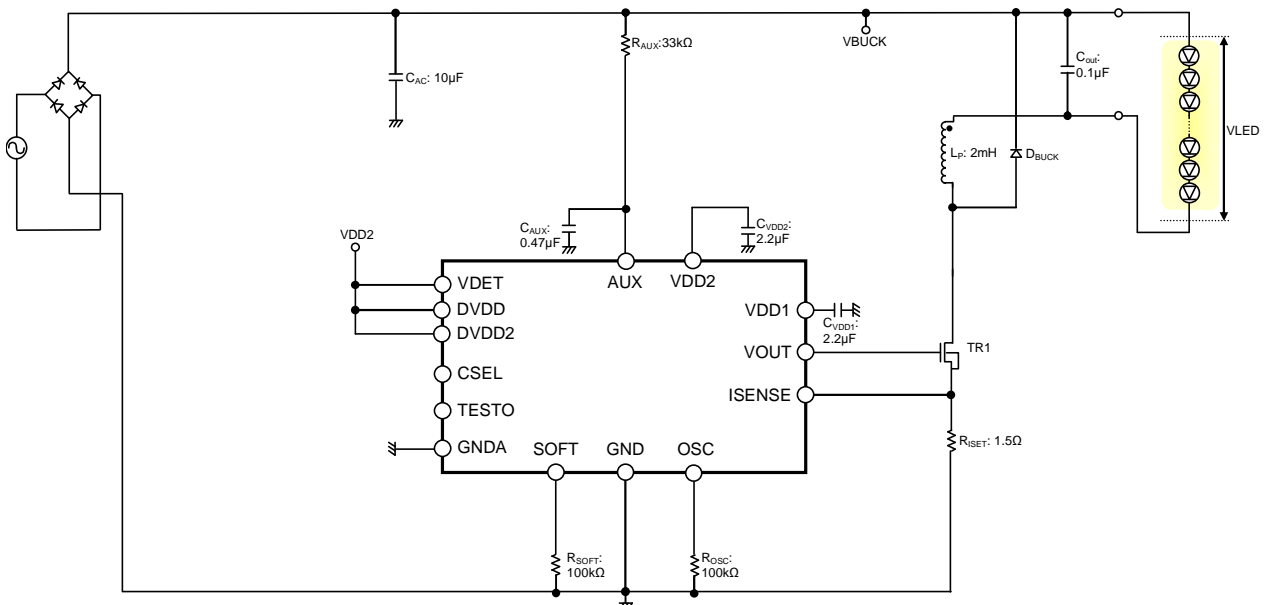

Fig.20 Application Example (Miniaturization : High-Power LED 333mA)

3) Circuit Example for Electrolytic free

Connect VDET and CSEL pin to the "Electrolytic Capacitor Less Circuit".

This application is not used Electrolytic-capacitor, is used two ceramic-capacitor. Two capacitor controls is available to stable constant LED current, when AC input voltage is low.

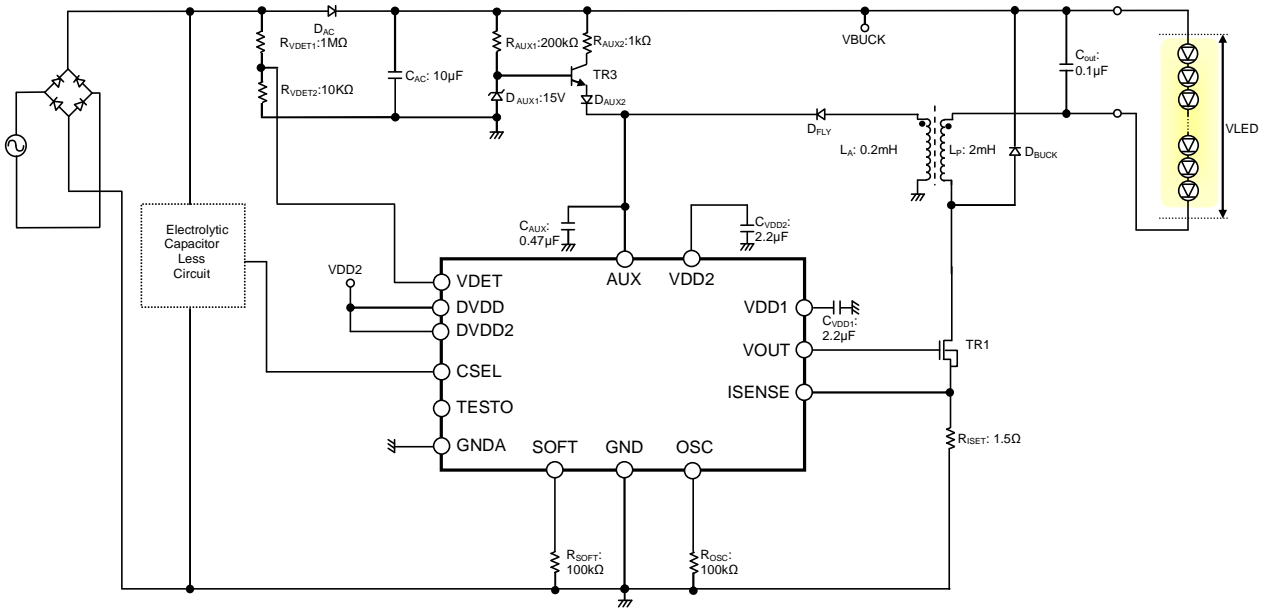

Fig.21 Application Example (Electrolytic free : High-Power LED 333mA)

●Operational Notes**(1) Absolute Maximum Ratings**

An excess in the absolute maximum ratings, such as supply voltage, temperature range of operating conditions, etc., can break down devices, thus making impossible to identify breaking mode such as a short circuit or an open circuit. If any special mode exceeding the absolute maximum ratings is assumed, consideration should be given to take physical safety measures including the use of fuses, etc.

(2) Operating conditions

These conditions represent a range within which characteristics can be provided approximately as expected. The electrical characteristics are guaranteed under the conditions of each parameter.

(3) Power supply line

Design PCB pattern to provide low impedance for the wiring between the power supply and the GND lines. In this regard, for the digital block power supply and the analog block power supply, even though these power supplies has the same level of potential, separate the power supply pattern for the digital block from that for the analog block, thus suppressing the diffraction of digital noises to the analog block power supply resulting from impedance common to the wiring patterns. For the GND line, give consideration to design the patterns in a similar manner.

Furthermore, for all power supply terminals to ICs, mount a capacitor between the power supply and the GND terminal. At the same time, in order to use an electrolytic capacitor, thoroughly check to be sure the characteristics of the capacitor to be used present no problem including the occurrence of capacity dropout at a low temperature, thus determining the constant.

(4) GND voltage

Make setting of the potential of the GND terminal so that it will be maintained at the minimum in any operating state. Furthermore, check to be sure no terminals are at a potential lower than the GND voltage including an actual electric transient.

(5) Short circuit between terminals and erroneous mounting

In order to mount ICs on a set PCB, pay thorough attention to the direction and offset of the ICs. Erroneous mounting can break down the ICs. Furthermore, if a short circuit occurs due to foreign matters entering between terminals or between the terminal and the power supply or the GND terminal, the ICs can break down.

(6) Operation in strong electromagnetic field

Be noted that using ICs in the strong electromagnetic field can malfunction them.

(7) Inspection with set PCB

On the inspection with the set PCB, if a capacitor is connected to a low-impedance IC terminal, the IC can suffer stress. Therefore, be sure to discharge from the set PCB by each process. Furthermore, in order to mount or dismount the set PCB to/from the jig for the inspection process, be sure to turn OFF the power supply and then mount the set PCB to the jig. After the completion of the inspection, be sure to turn OFF the power supply and then dismount it from the jig. In addition, for protection against static electricity, establish a ground for the assembly process and pay thorough attention to the transportation and the storage of the set PCB.

(8) Input terminals

In terms of the construction of IC, parasitic elements are inevitably formed in relation to potential. The operation of the parasitic element can cause interference with circuit operation, thus resulting in a malfunction and then breakdown of the input terminal. Therefore, pay thorough attention not to handle the input terminals, such as to apply to the input terminals a voltage lower than the GND respectively, so that any parasitic element will operate. Furthermore, do not apply a voltage to the input terminals when no power supply voltage is applied to the IC. In addition, even if the power supply voltage is applied, apply to the input terminals a voltage lower than the power supply voltage or within the guaranteed value of electrical characteristics.

(9) Ground wiring pattern

If small-signal GND and large-current GND are provided, It will be recommended to separate the large-current GND pattern from the small-signal GND pattern and establish a single ground at the reference point of the set PCB so that resistance to the wiring pattern and voltage fluctuations due to a large current will cause no fluctuations in voltages of the small-signal GND. Pay attention not to cause fluctuations in the GND wiring pattern of external parts as well.

(10) External capacitor

In order to use a ceramic capacitor as the external capacitor, determine the constant with consideration given to a degradation in the nominal capacitance due to DC bias and changes in the capacitance due to temperature, etc.

(11) Thermal shutdown circuit (TSD)

When junction temperatures become higher than detection temperatures, the thermal shutdown circuit operates and turns a switch OFF. The thermal shutdown circuit, which is aimed at isolating the LSI from thermal runaway as much as possible, is not aimed at the protection or guarantee of the LSI. Therefore, do not continuously use the LSI with this circuit operating or use the LSI assuming its operation.

(12) Thermal design

Perform thermal design in which there are adequate margins by taking into account the permissible dissipation (Pd) in actual states of use.

(13) Selection of coil

Select the low DCR inductors to decrease power loss for DC/DC converter.

(14) The temperature range of operation guarantees functional operation only. The life of LSI is not guaranteed in this range. The life of LSI has derating according to the environment, such as Ta, humidity, Voltage and so on. In performing an apparatus design, please perform the design in consideration of life derating of LSI.

(15) About the function description or technical note or more

The function description and the application notebook are the design materials to design a set. So, the contents of the materials aren't always guaranteed. Please design application by having fully examination and evaluation include the external elements.

Status of this document

The Japanese version of this document is formal specification. A customer may use this translation version only for a reference to help reading the formal version.

If there are any differences in translation version of this document formal version takes priority

●Ordering Information

B D 5 5 5 A 1 A F V - E 2

Product name	Package FV : SSOP-B14	Packaging and forming specification E2: Embossed tape and reel
--------------	--------------------------	---

●Physical Dimension Tape and Reel Information

SSOP-B14

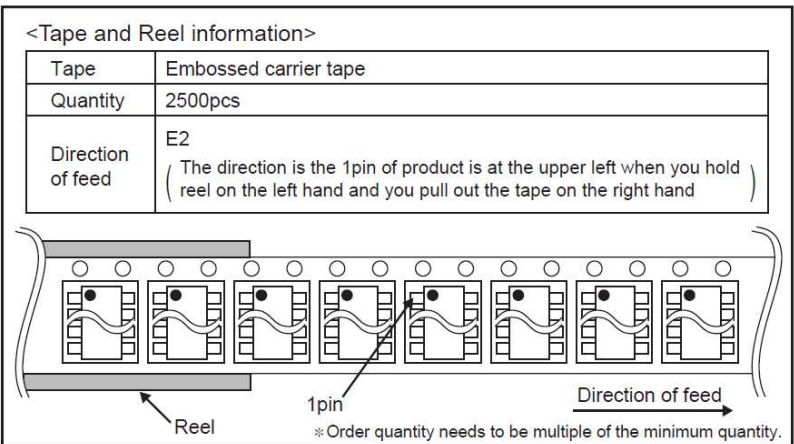
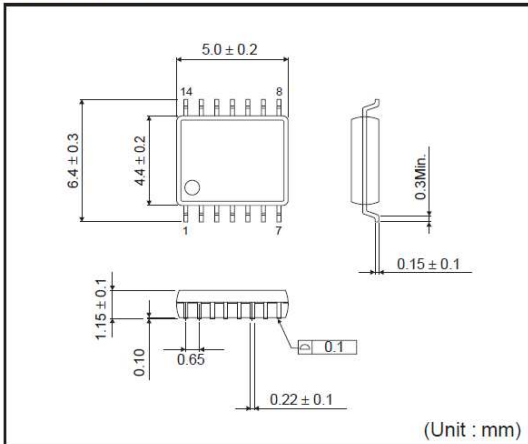

●Marking Diagram

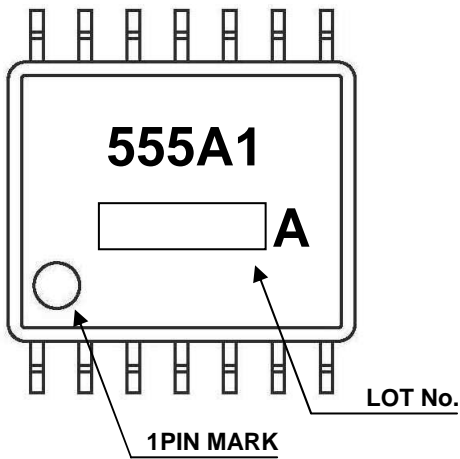

Notice

●General Precaution

- 1) Before you use our Products, you are requested to carefully read this document and fully understand its contents. ROHM shall not be in any way responsible or liable for failure, malfunction or accident arising from the use of any ROHM's Products against warning, caution or note contained in this document.
- 2) All information contained in this document is current as of the issuing date and subject to change without any prior notice. Before purchasing or using ROHM's Products, please confirm the latest information with a ROHM sales representative.

●Precaution on using ROHM Products

- 1) Our Products are designed and manufactured for application in ordinary electronic equipments (such as AV equipment, OA equipment, telecommunication equipment, home electronic appliances, amusement equipment, etc.). If you intend to use our Products in devices requiring extremely high reliability (such as medical equipment, transport equipment, traffic equipment, aircraft/spacecraft, nuclear power controllers, fuel controllers, car equipment including car accessories, safety devices, etc.) and whose malfunction or failure may cause loss of human life, bodily injury or serious damage to property ("Specific Applications"), please consult with the ROHM sales representative in advance. Unless otherwise agreed in writing by ROHM in advance, ROHM shall not be in any way responsible or liable for any damages, expenses or losses incurred by you or third parties arising from the use of any ROHM's Products for Specific Applications.
- 2) ROHM designs and manufactures its Products subject to strict quality control system. However, semiconductor products can fail or malfunction at a certain rate. Please be sure to implement, at your own responsibilities, adequate safety measures including but not limited to fail-safe design against the physical injury, damage to any property, which a failure or malfunction of our Products may cause. The following are examples of safety measures:
 - [a] Installation of protection circuits or other protective devices to improve system safety
 - [b] Installation of redundant circuits to reduce the impact of single or multiple circuit failure
- 3) Our Products are designed and manufactured for use under standard conditions and not under any special or extraordinary environments or conditions, as exemplified below. Accordingly, ROHM shall not be in any way responsible or liable for any damages, expenses or losses arising from the use of any ROHM's Products under any special or extraordinary environments or conditions. If you intend to use our Products under any special or extraordinary environments or conditions (as exemplified below), your independent verification and confirmation of product performance, reliability, etc. prior to use, must be necessary:
 - [a] Use of our Products in any types of liquid, including water, oils, chemicals, and organic solvents
 - [b] Use of our Products outdoors or in places where the Products are exposed to direct sunlight or dust
 - [c] Use of our Products in places where the Products are exposed to sea wind or corrosive gases, including Cl₂, H₂S, NH₃, SO₂, and NO₂
 - [d] Use of our Products in places where the Products are exposed to static electricity or electromagnetic waves
 - [e] Use of our Products in proximity to heat-producing components, plastic cords, or other flammable items
 - [f] Sealing or coating our Products with resin or other coating materials
 - [g] Use of our Products without cleaning residue of flux (even if you use no-clean type fluxes, cleaning residue of flux is recommended); or Washing our Products by using water or water-soluble cleaning agents for cleaning residue after soldering
 - [h] Use of the Products in places subject to dew condensation
- 4) The Products are not subject to radiation-proof design.
- 5) Please verify and confirm characteristics of the final or mounted products in using the Products.
- 6) In particular, if a transient load (a large amount of load applied in a short period of time, such as pulse) is applied, confirmation of performance characteristics after on-board mounting is strongly recommended. Avoid applying power exceeding normal rated power; exceeding the power rating under steady-state loading condition may negatively affect product performance and reliability.
- 7) De-rate Power Dissipation (Pd) depending on Ambient temperature (Ta). When used in sealed area, confirm the actual ambient temperature.
- 8) Confirm that operation temperature is within the specified range described in the product specification.
- 9) ROHM shall not be in any way responsible or liable for failure induced under deviant condition from what is defined in this document.

● **Precaution for Mounting / Circuit board design**

- 1) When a highly active halogenous (chlorine, bromine, etc.) flux is used, the residue of flux may negatively affect product performance and reliability.
- 2) In principle, the reflow soldering method must be used; if flow soldering method is preferred, please consult with the ROHM representative in advance.

For details, please refer to ROHM Mounting specification

● **Precautions Regarding Application Examples and External Circuits**

- 1) If change is made to the constant of an external circuit, please allow a sufficient margin considering variations of the characteristics of the Products and external components, including transient characteristics, as well as static characteristics.
- 2) You agree that application notes, reference designs, and associated data and information contained in this document are presented only as guidance for Products use. Therefore, in case you use such information, you are solely responsible for it and you must exercise your own independent verification and judgment in the use of such information contained in this document. ROHM shall not be in any way responsible or liable for any damages, expenses or losses incurred by you or third parties arising from the use of such information.

● **Precaution for Electrostatic**

This Product is electrostatic sensitive product, which may be damaged due to electrostatic discharge. Please take proper caution in your manufacturing process and storage so that voltage exceeding the Products maximum rating will not be applied to Products. Please take special care under dry condition (e.g. Grounding of human body / equipment / solder iron, isolation from charged objects, setting of Ionizer, friction prevention and temperature / humidity control).

● **Precaution for Storage / Transportation**

- 1) Product performance and soldered connections may deteriorate if the Products are stored in the places where:
 - [a] the Products are exposed to sea winds or corrosive gases, including Cl₂, H₂S, NH₃, SO₂, and NO₂
 - [b] the temperature or humidity exceeds those recommended by ROHM
 - [c] the Products are exposed to direct sunshine or condensation
 - [d] the Products are exposed to high Electrostatic
- 2) Even under ROHM recommended storage condition, solderability of products out of recommended storage time period may be degraded. It is strongly recommended to confirm solderability before using Products of which storage time is exceeding the recommended storage time period.
- 3) Store / transport cartons in the correct direction, which is indicated on a carton with a symbol. Otherwise bent leads may occur due to excessive stress applied when dropping of a carton.
- 4) Use Products within the specified time after opening a humidity barrier bag. Baking is required before using Products of which storage time is exceeding the recommended storage time period.

● **Precaution for Product Label**

QR code printed on ROHM Products label is for ROHM's internal use only.

● **Precaution for Disposition**

When disposing Products please dispose them properly using an authorized industry waste company.

● **Precaution for Foreign Exchange and Foreign Trade act**

Since our Products might fall under controlled goods prescribed by the applicable foreign exchange and foreign trade act, please consult with ROHM representative in case of export.

● **Precaution Regarding Intellectual Property Rights**

- 1) All information and data including but not limited to application example contained in this document is for reference only. ROHM does not warrant that foregoing information or data will not infringe any intellectual property rights or any other rights of any third party regarding such information or data. ROHM shall not be in any way responsible or liable for infringement of any intellectual property rights or other damages arising from use of such information or data.:
- 2) No license, expressly or implied, is granted hereby under any intellectual property rights or other rights of ROHM or any third parties with respect to the information contained in this document.

●Other Precaution

- 1) The information contained in this document is provided on an “as is” basis and ROHM does not warrant that all information contained in this document is accurate and/or error-free. ROHM shall not be in any way responsible or liable for any damages, expenses or losses incurred by you or third parties resulting from inaccuracy or errors of or concerning such information.
- 2) This document may not be reprinted or reproduced, in whole or in part, without prior written consent of ROHM.
- 3) The Products may not be disassembled, converted, modified, reproduced or otherwise changed without prior written consent of ROHM.
- 4) In no event shall you use in any way whatsoever the Products and the related technical information contained in the Products or this document for any military purposes, including but not limited to, the development of mass-destruction weapons.
- 5) The proper names of companies or products described in this document are trademarks or registered trademarks of ROHM, its affiliated companies or third parties.





Компания «ЭлектроПласт» предлагает заключение долгосрочных отношений при поставках импортных электронных компонентов на взаимовыгодных условиях!

Наши преимущества:

- Оперативные поставки широкого спектра электронных компонентов отечественного и импортного производства напрямую от производителей и с крупнейших мировых складов;
- Поставка более 17-ти миллионов наименований электронных компонентов;
- Поставка сложных, дефицитных, либо снятых с производства позиций;
- Оперативные сроки поставки под заказ (от 5 рабочих дней);
- Экспресс доставка в любую точку России;
- Техническая поддержка проекта, помощь в подборе аналогов, поставка прототипов;
- Система менеджмента качества сертифицирована по Международному стандарту ISO 9001;
- Лицензия ФСБ на осуществление работ с использованием сведений, составляющих государственную тайну;
- Поставка специализированных компонентов (Xilinx, Altera, Analog Devices, Intersil, Interpoint, Microsemi, Aeroflex, Peregrine, Syfer, Eurofarad, Texas Instrument, Miteq, Cobham, E2V, MA-COM, Hittite, Mini-Circuits, General Dynamics и др.);

Помимо этого, одним из направлений компании «ЭлектроПласт» является направление «Источники питания». Мы предлагаем Вам помощь Конструкторского отдела:

- Подбор оптимального решения, техническое обоснование при выборе компонента;
- Подбор аналогов;
- Консультации по применению компонента;
- Поставка образцов и прототипов;
- Техническая поддержка проекта;
- Защита от снятия компонента с производства.



Как с нами связаться

Телефон: 8 (812) 309 58 32 (многоканальный)

Факс: 8 (812) 320-02-42

Электронная почта: org@eplast1.ru

Адрес: 198099, г. Санкт-Петербург, ул. Калинина, дом 2, корпус 4, литера А.