

### FEATURES

- RoHS compliant
- Single or dual output
- 1kVDC isolation
- Pin compatible with NMXU series
- Power density 0.53W/cm<sup>3</sup>
- UL 94V-0 package material
- Footprint 9.52cm<sup>2</sup>
- Industry standard pinout
- 5V & 12V input
- 5V & 15V output
- Short circuit protected
- Internal SMD construction
- Fully encapsulated with toroidal magnetics
- Output regulation 0.5%
- PCB mounting

### DESCRIPTION

The NMXSO series of DC/DC converters is particularly suited to isolating and/or converting DC power rails. The galvanic isolation allows the device to be configured to provide an isolated negative rail in systems where only positive rails exist. The devices are particularly suited for use in distributed power systems where there is low variation in the bus voltage levels.

### SELECTION GUIDE

Order Code	Nominal Input Voltage	Output Voltage	Output Current	Efficiency Typ.	Isolation Capacitance	Output Power	MTTF <sup>1</sup>
	V	V	A	%	pF	W	kHrs
NMXD0505SOC	5	±5	±0.5	65	30.5	5.0	565
NMXD0515SOC	5	±15	±0.2	65	36.6	6.0	83
NMXD1205SOC	12	±5	±0.5	65	40.5	5.0	162
NMXD1215SOC	12	±15	±0.2	65	65.7	6.0	61
NMXS0505SOC	5	5	1.0	65	37.4	5.0	811
NMXS0515SOC	5	15	0.4	65	33.3	6.0	157
NMXS1205SOC	12	5	1.0	65	46.6	5.0	177
NMXS1215SOC	12	15	0.4	65	60.0	6.0	93
NMXD0512SOC	Obsolete						n/a
NMXD1212SOC	Obsolete, recommended alternative: <a href="#">(click for data sheet)</a>						NCS6D1212C
NMXS0512SOC	Obsolete						n/a
NMXS1212SOC	Obsolete, recommended alternative: <a href="#">(click for data sheet)</a>						NCS6S1212C

When operated **with** additional external load capacitance the rise time of the input voltage will determine the maximum external capacitance value for guaranteed start up. The slower the rise time of the input voltage the greater the maximum value of the additional external capacitance for reliable start up.

### INPUT CHARACTERISTICS

Parameter	Conditions	Min.	Typ.	Max.	Units
Voltage range	Continuous operation, 5V input types	4.5	5.0	5.5	V
	Continuous operation, 12V input types	10.8	12.0	13.2	
Reflected ripple voltage	BW=DC to 20MHz, all output types			150	mV

### OUTPUT CHARACTERISTICS

Parameter	Conditions	Min.	Typ.	Max.	Units
Rated power	T <sub>A</sub> = 0°C to 70°C			5.0	W
Voltage output accuracy				±3	%
Line regulation	High V <sub>IN</sub> to low V <sub>IN</sub>			±0.5	%
Load Regulation	10% load to rated load			0.5	%
Ripple and Noise	BW=DC to 20MHz, all output types			150	mV p-p

### ABSOLUTE MAXIMUM RATINGS

Short-circuit protection <sup>2</sup>	15 seconds
Lead temperature 1.5mm from case for 10 seconds	300°C
Input voltage V <sub>IN</sub> , NMXSO05 types	7V
Input voltage V <sub>IN</sub> , NMXSO12 types	15V

1. Calculated using MIL-HDBK-217F with nominal input voltage at full load.
  2. Supply voltage must be disconnected at the end of the short circuit duration.
- All specifications typical at T<sub>A</sub>=25°C, nominal input voltage and rated output current unless otherwise specified.



### ISOLATION CHARACTERISTICS

Parameter	Conditions	Min.	Typ.	Max.	Units
Isolation test voltage	Flash tested for 1 second	1000			VDC
Resistance	Viso= 1000VDC	1			GΩ

### GENERAL CHARACTERISTICS

Parameter	Conditions	Min.	Typ.	Max.	Units
Switching frequency	All input types		70		kHz

### TEMPERATURE CHARACTERISTICS

Parameter	Conditions	Min.	Typ.	Max.	Units
Specification	All output types	0		70	°C
Storage		-55		100	
Case Temperature above ambient	All output types		30		
Cooling	Free air convection				

### RoHS COMPLIANCE INFORMATION



This series is compatible with RoHS soldering systems with a peak wave solder temperature of 300°C for 10 seconds. The pin termination finish on this product series is Matte Tin over Nickel Preplate. The series is backward compatible with Sn/Pb soldering systems. For further information, please visit [www.murata-ps.com/rohs](http://www.murata-ps.com/rohs)

### TECHNICAL NOTES

#### ISOLATION VOLTAGE

'Hi Pot Test', 'Flash Tested', 'Withstand Voltage', 'Proof Voltage', 'Dielectric Withstand Voltage' & 'Isolation Test Voltage' are all terms that relate to the same thing, a test voltage, applied for a specified time, across a component designed to provide electrical isolation, to verify the integrity of that isolation.

Murata Power Solutions NMXSO series of DC/DC converters are all 100% production tested at their stated isolation voltage. This is 1kVDC for 1 second.

A question commonly asked is, "What is the continuous voltage that can be applied across the part in normal operation?"

For a part holding no specific agency approvals, such as the NMXSO series, both input and output should normally be maintained within SELV limits i.e. less than 42.4V peak, or 60VDC. The isolation test voltage represents a measure of immunity to transient voltages and the part should never be used as an element of a safety isolation system. The part could be expected to function correctly with several hundred volts offset applied continuously across the isolation barrier; but then the circuitry on both sides of the barrier must be regarded as operating at an unsafe voltage and further isolation/insulation systems must form a barrier between these circuits and any user-accessible circuitry according to safety standard requirements.

#### REPEATED HIGH-VOLTAGE ISOLATION TESTING

It is well known that repeated high-voltage isolation testing of a barrier component can actually degrade isolation capability, to a lesser or greater degree depending on materials, construction and environment. The NMXSO series has toroidal isolation transformers, with no additional insulation between primary and secondary windings of enameled wire. While parts can be expected to withstand several times the stated test voltage, the isolation capability does depend on the wire insulation. Any material, including this enamel (typically polyurethane) is susceptible to eventual chemical degradation when subject to very high applied voltages thus implying that the number of tests should be strictly limited. We therefore strongly advise against repeated high voltage isolation testing, but if it is absolutely required, that the voltage be reduced by 20% from specified test voltage.

This consideration equally applies to agency recognized parts rated for better than functional isolation where the wire enamel insulation is always supplemented by a further insulation system of physical spacing or barriers.

## PACKAGE SPECIFICATIONS

### MECHANICAL DIMENSIONS

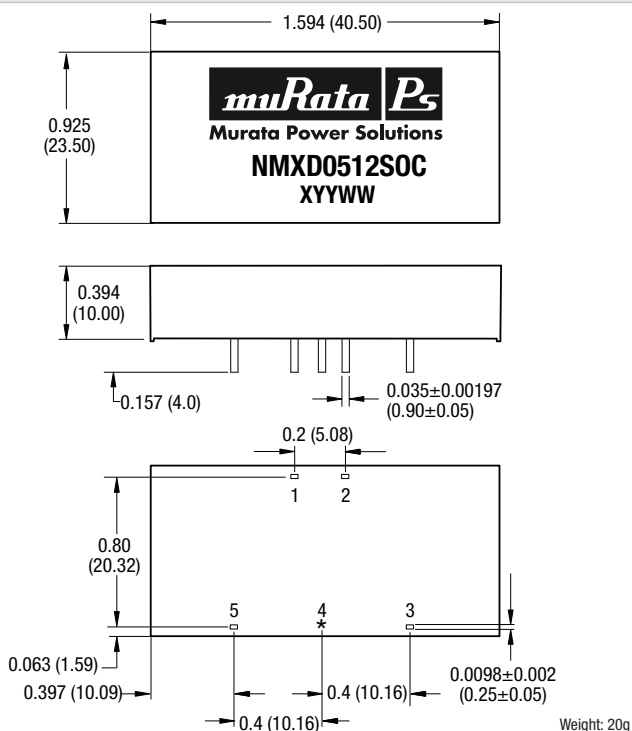

\* Pin not fitted on single output variants.  
All dimensions in inches  $\pm 0.01$  (mm  $\pm 0.25$ mm). All pins on a 0.1 (2.54) pitch and within  $\pm 0.01$  (0.25) of true position.

### PIN CONNECTIONS

Single Output Variants	
Pin	Function
1	-V <sub>IN</sub>
2	+V <sub>IN</sub>
3	+V <sub>OUT</sub>
4	Not fitted
5	-V <sub>OUT</sub>

Dual Output Variants	
Pin	Function
1	-V <sub>IN</sub>
2	+V <sub>IN</sub>
3	+V <sub>OUT</sub>
4	Common
5	-V <sub>OUT</sub>

### RECOMMENDED FOOTPRINT DETAILS

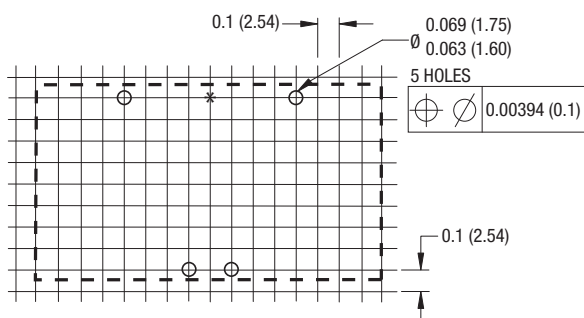

\* Hole not required for single output variants  
All dimensions in inches  $\pm 0.01$  (mm  $\pm 0.25$ mm).

### TUBE OUTLINE DIMENSIONS

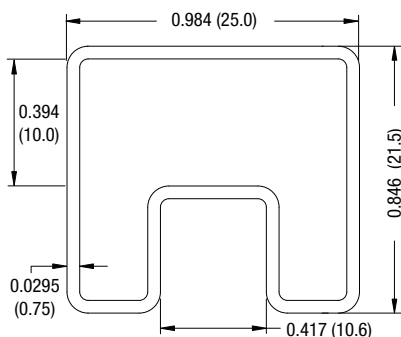

Not to scale.  
All dimensions in inches  $\pm 0.01$  (mm  $\pm 0.25$ mm).

Murata Power Solutions, Inc.  
11 Cabot Boulevard, Mansfield, MA 02048-1151 U.S.A.  
ISO 9001 and 14001 REGISTERED



This product is subject to the following [operating requirements](#) and the [Life and Safety Critical Application Sales Policy](#). Refer to: <http://www.murata-ps.com/requirements/>

Murata Power Solutions, Inc. makes no representation that the use of its products in the circuits described herein, or the use of other technical information contained herein, will not infringe upon existing or future patent rights. The descriptions contained herein do not imply the granting of licenses to make, use, or sell equipment constructed in accordance therewith. Specifications are subject to change without notice. © 2012 Murata Power Solutions, Inc.



Компания «ЭлектроПласт» предлагает заключение долгосрочных отношений при поставках импортных электронных компонентов на взаимовыгодных условиях!

Наши преимущества:

- Оперативные поставки широкого спектра электронных компонентов отечественного и импортного производства напрямую от производителей и с крупнейших мировых складов;
- Поставка более 17-ти миллионов наименований электронных компонентов;
- Поставка сложных, дефицитных, либо снятых с производства позиций;
- Оперативные сроки поставки под заказ (от 5 рабочих дней);
- Экспресс доставка в любую точку России;
- Техническая поддержка проекта, помощь в подборе аналогов, поставка прототипов;
- Система менеджмента качества сертифицирована по Международному стандарту ISO 9001;
- Лицензия ФСБ на осуществление работ с использованием сведений, составляющих государственную тайну;
- Поставка специализированных компонентов (Xilinx, Altera, Analog Devices, Intersil, Interpoint, Microsemi, Aeroflex, Peregrine, Syfer, Eurofarad, Texas Instrument, Miteq, Cobham, E2V, MA-COM, Hittite, Mini-Circuits, General Dynamics и др.);

Помимо этого, одним из направлений компании «ЭлектроПласт» является направление «Источники питания». Мы предлагаем Вам помощь Конструкторского отдела:

- Подбор оптимального решения, техническое обоснование при выборе компонента;
- Подбор аналогов;
- Консультации по применению компонента;
- Поставка образцов и прототипов;
- Техническая поддержка проекта;
- Защита от снятия компонента с производства.



#### Как с нами связаться

**Телефон:** 8 (812) 309 58 32 (многоканальный)

**Факс:** 8 (812) 320-02-42

**Электронная почта:** [org@eplast1.ru](mailto:org@eplast1.ru)

**Адрес:** 198099, г. Санкт-Петербург, ул. Калинина, дом 2, корпус 4, литера А.