

# High Frequency Ceramic Solutions

## Miniature 2.45GHz Impedance Matched Front-End Filter Optimized for Semtech SX1280, SX1281

P/N 2450FM07D0034

Detail Specification: 9/10/2019

Page 1 of 4

AEC-Q200 qualified component available, contact us at: [www.johansontechnology.com/ask-a-question](http://www.johansontechnology.com/ask-a-question)

### General Specifications

Part Number	2450FM07D0034
Frequency (MHz)	2400 - 2500
Insertion loss (dB)	0.75 Typ. (1.0 max.)
Return Loss (dB)	14 Typ. (10 min.)
Input Impedance (Terminal Toward Chipset)	Impedance matched to Semtech SX1280, SX1281
Output Impedance	50Ω
Power Capacity	3W max. (CW)

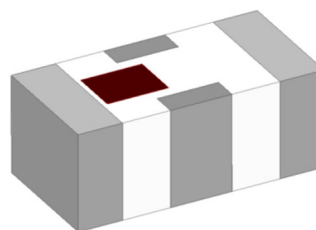

Attenuation (dB)		Reel Quantity	Storage Temperature
4800 - 5000MHz	35 Typ. (30 min.)	10,000 pcs	-40 to +85°C
7200 - 7500MHz	30 Typ. (25 min.)	Operating Temperature	-40 to +85°C
9600 - 10000MHz	30 Typ. (25 min.)	Recommended Storage Conditions for unused T&R product	+5 to +35°C, Humidity: 45-75%RH, 18 mo. Max.
12000 - 12500MHz	25 Typ. (20 min.)		
14400 - 15000MHz	9.5 Typ. (4.5 min.)		
16800 - 17000MHz	8.0 Typ. (3.0 min.)		

This component is internally DC blocked. External DC blocking cap not needed!

### Part Number Explanation

P/N Suffix	Packaging Style	Bulk	Suffix = S	E.g. 2450FM07D0034S
		T & R	Suffix = T	E.g. 2450FM07D0034T
	Termination Style	100% Tin	Suffix = None	E.g. 2450FM07D0034(T or S)

You can download the measured s-parameter file for this component at: <https://www.johansontechnology.com/semtech>

### Mechanical Dimensions

	In	mm
L	0.039 ± 0.002	1.00 ± 0.05
W	0.020 ± 0.002	0.50 ± 0.05
T	0.016 max.	0.40 max.
a	0.007 ± 0.004	0.18 ± 0.10
b	0.010 ± 0.004	0.25 ± 0.10

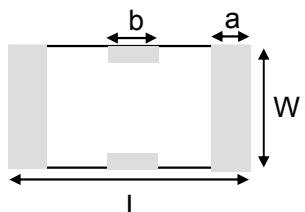
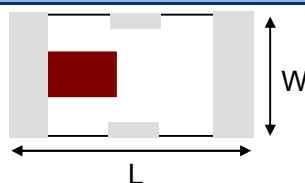
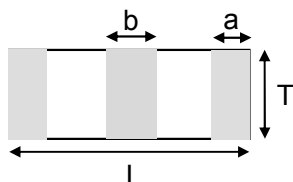

### Terminal Configuration

No.	Function
1	IN (Toward the chipset)
2	GND
3	OUT (Toward the antenna)
4	GND

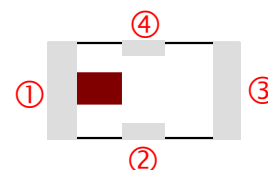

Johanson Technology, Inc. reserves the right to make design changes without notice.

All sales are subject to Johanson Technology, Inc. terms and conditions.



<https://www.johansontechnology.com>

4001 Calle Tecate • Camarillo, CA 93012, USA • TEL +1.805.389.1166

Ver. 1.2

2019 Johanson Technology, Inc. All Rights Reserved

# High Frequency Ceramic Solutions

Miniature 2.45GHz Impedance Matched Front-End Filter Optimized for Semtech SX1280, SX1281



P/N 2450FM07D0034

Detail Specification: 9/10/2019

Page 2 of 4

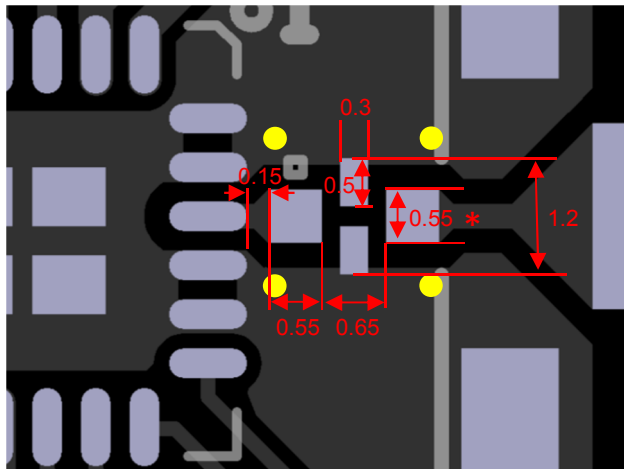
## Mounting Pad Dimensions



-  Solder Resist
-  Land
-  Through-hole ( $\phi$  0.20)

\*Line width should be designed to match 50 $\Omega$  characteristic impedance, depending on PCB material and thickness.

Do you need the layout files of the above? Go to: <https://www.johansontechnology.com/ask-a-question>

## Measurement Schematic

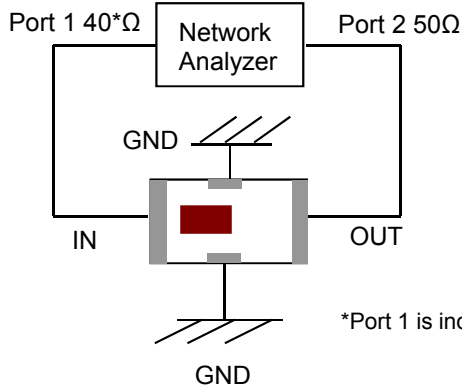

Port 1: Filter IN (red marking side toward chipset)  
Port 2: Filter OUT (toward antenna)

\*Port 1 is indeed 40ohms!

Johanson Technology, Inc. reserves the right to make design changes without notice.

All sales are subject to Johanson Technology, Inc. terms and conditions.



Ver. 1.2

<https://www.johansontechnology.com>

4001 Calle Tecate • Camarillo, CA 93012, USA • TEL +1.805.389.1166

2019 Johanson Technology, Inc. All Rights Reserved

# High Frequency Ceramic Solutions

Miniature 2.45GHz Impedance Matched Front-End Filter Optimized for  
Semtech SX1280, SX1281

P/N 2450FM07D0034

Detail Specification: 9/10/2019

Page 3 of 4

## Typical Electrical Characteristics (T=25°C)

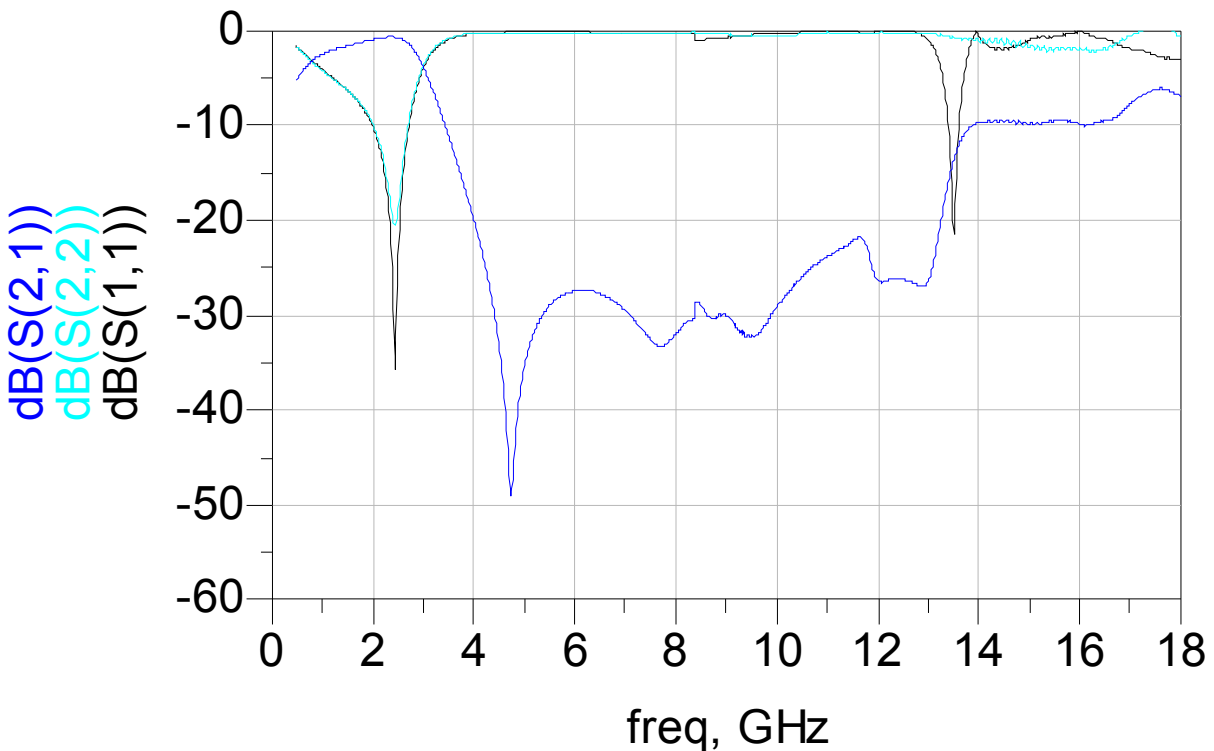

If you would like recommendation on a mini 2.4G embedded antenna, free layout verification, reference design files (gerbers, schematic, etc) or s-parameter files, please contact us at:

<https://www.johansontechnology.com/ask-a-question>

Johanson Technology, Inc. reserves the right to make design changes without notice.

All sales are subject to Johanson Technology, Inc. terms and conditions.



Ver. 1.2

<https://www.johansontechnology.com>

4001 Calle Tecate • Camarillo, CA 93012, USA • TEL +1.805.389.1166

2019 Johanson Technology, Inc. All Rights Reserved

# High Frequency Ceramic Solutions

**Miniature 2.45GHz Impedance Matched Front-End Filter Optimized for Semtech SX1280, SX1281**

P/N 2450FM07D0034

Detail Specification: 9/10/2019

Page 4 of 4

## Application Notes, Layout Files, and more

<https://www.johansontechnology.com/semtech>

## Packaging information

<https://www.johansontechnology.com/tape-reel-packaging>

## Soldering Information

<https://www.johansontechnology.com/ipcsoldering-profile>

## MSL Info

<https://www.johansontechnology.com/msl-rating>

## Recommended Storage Condition and Max Shelf Life

<https://www.johansontechnology.com/recommended-storage-conditions>

## RoHS Compliance

<https://www.johansontechnology.com/rohs-compliance>

## Antenna layout and tuning techniques

<https://www.johansontechnology.com/tuning>

## Antenna layout review, tuning, and characterization services

<https://www.johansontechnology.com/ipc-antenna-services>

Johanson uses 6/6 RoHS Green Low-Temperature-Co-fired-Ceramic (LTCC) integrated passive technology in a 4-pin (Sn plated) monolithic structure. This component is 100% RF Tested, making it a more reliable system, impedance controlled environment, consistent-guaranteed RF performance in a very small RF front end-solution compared to the L/C discrete solution.



Johanson Technology, Inc. reserves the right to make design changes without notice.

All sales are subject to Johanson Technology, Inc. terms and conditions.



Ver. 1.2

<https://www.johansontechnology.com>

4001 Calle Tecate • Camarillo, CA 93012, USA • TEL +1.805.389.1166

2019 Johanson Technology, Inc. All Rights Reserved



Компания «ЭлектроПласт» предлагает заключение долгосрочных отношений при поставках импортных электронных компонентов на взаимовыгодных условиях!

Наши преимущества:

- Оперативные поставки широкого спектра электронных компонентов отечественного и импортного производства напрямую от производителей и с крупнейших мировых складов;
- Поставка более 17-ти миллионов наименований электронных компонентов;
- Поставка сложных, дефицитных, либо снятых с производства позиций;
- Оперативные сроки поставки под заказ (от 5 рабочих дней);
- Экспресс доставка в любую точку России;
- Техническая поддержка проекта, помощь в подборе аналогов, поставка прототипов;
- Система менеджмента качества сертифицирована по Международному стандарту ISO 9001;
- Лицензия ФСБ на осуществление работ с использованием сведений, составляющих государственную тайну;
- Поставка специализированных компонентов (Xilinx, Altera, Analog Devices, Intersil, Interpoint, Microsemi, Aeroflex, Peregrine, Syfer, Eurofarad, Texas Instrument, Miteq, Cobham, E2V, MA-COM, Hittite, Mini-Circuits, General Dynamics и др.);

Помимо этого, одним из направлений компании «ЭлектроПласт» является направление «Источники питания». Мы предлагаем Вам помощь Конструкторского отдела:

- Подбор оптимального решения, техническое обоснование при выборе компонента;
- Подбор аналогов;
- Консультации по применению компонента;
- Поставка образцов и прототипов;
- Техническая поддержка проекта;
- Защита от снятия компонента с производства.



#### Как с нами связаться

**Телефон:** 8 (812) 309 58 32 (многоканальный)

**Факс:** 8 (812) 320-02-42

**Электронная почта:** [org@eplast1.ru](mailto:org@eplast1.ru)

**Адрес:** 198099, г. Санкт-Петербург, ул. Калинина, дом 2, корпус 4, литера А.