

BMD-100 Module for Bluetooth 4.1 LE

The **BLUMOD BMD-100** is a Bluetooth Smart master/slave network processor module targeted for low-power sensors and accessories using the ultralow power STMicroelectronics BlueNRG-MS chipset. It integrates features required for a Bluetooth Smart application, including Bluetooth radio, software stack, and GATT/ATT-based access. The external host application processor, where the application resides, connects using SPI. This allows the best microcontroller for the application to be chosen. C based Bluetooth Low Energy profiles are available for compiling into your application.



The module can be powered directly from a standard 3V coin cell battery or a pair of AAA batteries with a maximum input current of only 15 mA at the highest output power. On-module flash memory allows in the field Bluetooth low energy stack upgrades.



1. Features

- ⚙ Bluetooth v4.1 compliant master, slave and multiple roles simultaneously
- ⚙ Embedded Bluetooth low energy protocol stack: GAP, GATT, SM, L2CAP, LL, RF-PHY
- ⚙ C based Bluetooth low energy profiles
- ⚙ High performance, ultra-low power Cortex-M0 32-bit architecture core
- ⚙ SPI application controller interface (ACI)
- ⚙ Operating supply voltage: 1.7 to 3.6 V
- ⚙ 8.2 mA maximum TX current (@0 dBm, 3.0 V)
- ⚙ Down to 1.7 μ A current consumption with active BLE stack
- ⚙ Integrated linear regulator and DC-DC step-down converter
- ⚙ Up to +8 dBm available output power
- ⚙ Excellent RF link budget (up to 96 dB)
- ⚙ Accurate RSSI to allow power control
- ⚙ Full link controller and host security
- ⚙ On-chip non-volatile Flash memory
- ⚙ AES security co-processor
- ⚙ Low power modes
- ⚙ 32 MHz crystal oscillator
- ⚙ 32 kHz ring oscillator
- ⚙ Optional 32 kHz crystal oscillator
- ⚙ Battery voltage monitor and temperature sensor
- ⚙ Operating temperature range: -40 °C to 85 °C
- ⚙ FCC, IC, and CE certifications



2. Ordering Information

Email modules@rigado.com for quotes and ordering or visit www.rigado.com/bmd-100

Part Number	Description
BMD-100-A-R	BMD-100 module, Rev A, Tape & Reel
BMD-100-NUCL	BMD-100 Nucleo Shield
BMD-100-EVAL	BMD-100 Evaluation Kit (Nucleo Shield + Nucleo Platform)

Table 1 - Ordering Part Numbers

3. Hardware Block Diagram

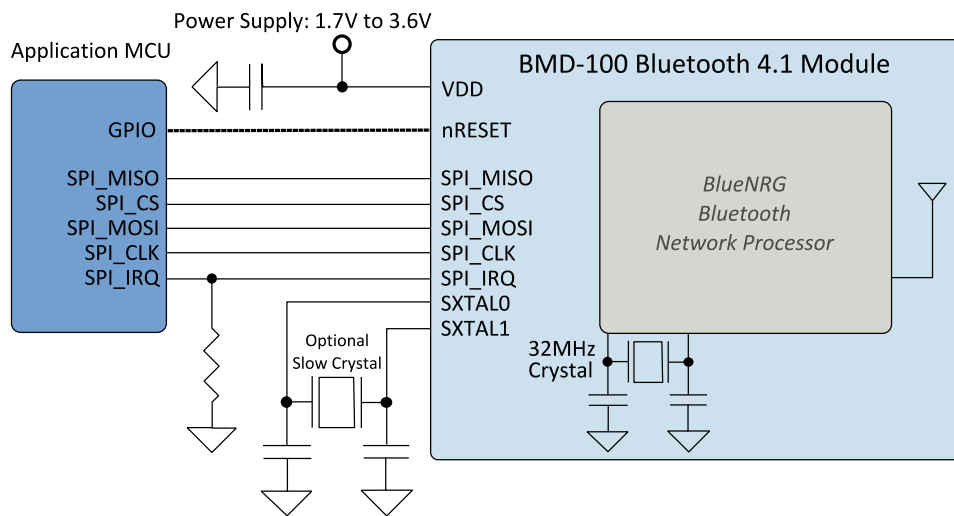

Figure 1 – Hardware Block Diagram

4. Software Block Diagram

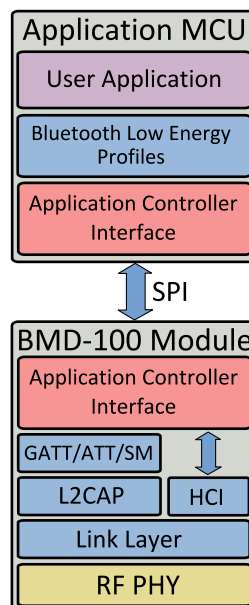

Figure 2 – Software Block Diagram

Table of Contents

1. FEATURES	1
2. ORDERING INFORMATION	2
3. HARDWARE BLOCK DIAGRAM	2
4. SOFTWARE BLOCK DIAGRAM	2
5. QUICK SPECIFICATIONS	4
6. PIN DESCRIPTIONS	5
7. ELECTRICAL SPECIFICATIONS	6
7.1. ABSOLUTE MAXIMUM RATINGS	6
7.2. OPERATING CONDITIONS	6
7.3. SPI INTERFACE	6
7.4. CLOCKS	6
7.5. NOTE	7
8. APPLICATION CONTROLLER INTERFACE	7
9. MECHANICAL DATA	8
9.1. MODULE DIMENSIONS	8
9.2. RECOMMENDED PCB LAND PAD	8
10. MODULE MARKING	9
11. RF DESIGN NOTES	9
11.1. RECOMMENDED RF LAYOUT & GROUND PLANE	9
11.2. MECHANICAL ENCLOSURE	10
12. EVALUATION BOARDS	10
13. REGULATORY STATEMENTS	11
13.1. FCC STATEMENT:	11
13.2. FCC IMPORTANT NOTES:	11
13.3. IC STATEMENT:	12
13.4. IC IMPORTANT NOTES:	13
13.5. CE REGULATORY:	13
14. SOLDER REFLOW TEMPERATURE-TIME PROFILE	14
15. LABELING	14
15.1. PACKAGING LABEL	14
16. CAUTIONS	15
17. LIFE SUPPORT POLICY	15
18. DOCUMENT HISTORY	15
19. RELATED DOCUMENTS	16

5. Quick Specifications

Bluetooth	
Version	4.1 (<i>Bluetooth Smart</i>) Peripheral & Central
Security	AES-128
LE connections	up to 8
Radio	
Frequency	2.402GHz to 2.480GHz
Modulation	GFSK at 1 Mbps
Transmit power	+8 dBm
Receiver sensitivity	-88 dBm (BLE mode)
Antenna	Integrated ceramic chip
Current Consumption	
TX only @ +8 dBm, 4 dBm, 2 dBm	15.1 mA, 10.9 mA, 8.2 mA
RX only	7.7 mA
CPU, Flash and RAM on/off	3.3 mA, 2.0 mA
Sleep, 32kHz XO/RO	2.4 μ A, 3.5 μ A
Standby, (RAM2 Off)	1.3 μ A
Reset	5 nA
Dimensions	
Length	13.6 mm +/-0.2mm
Width	8.4 mm +/-0.2mm
Height	1.8 mm +/-0.2mm
Hardware	
Interface	ACI over SPI with IRQ and Reset (8 MHz Max)
Power supply	1.7V to 3.6V
Planned Certifications (Jan 2015)	
FCC	FCC part 15 modular qualification – FCC ID: 2AA9B02
IC	Industry Canada RSS-210 modular qualification – IC: 12208A-02
CE	EN 60950-1: 2011-01 3.1 (a) : Health and Safety of the User EN 301 489-17 V2.2.1 3.1 (b) : Electromagnetic Compatibility EN 300 328 V1.8.1 3.2 : Effective use of spectrum allocated

Table 2- Quick Specifications

6. Pin Descriptions

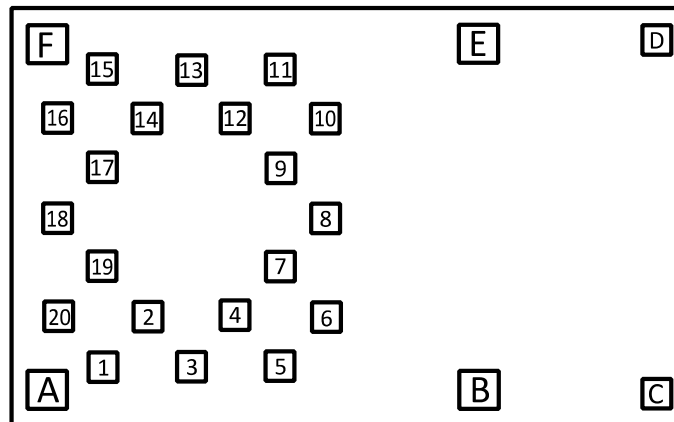

Figure 3- Pin out (Top View)

Pin description

Pin	Name	Direction	Description
14	SPI_CS	In	SPI slave select = SPI enable.
17	SPI_CLK	In	SPI clock (max 8 MHz).
16	SPI_MOSI	In	Master output, slave input.
15	SPI_MISO	Out	Master input, slave output.
18	SPI_IRQ	Out	Slave has data for master.
13	nRESET	In	Reset and deep sleep control
10	SXTAL0	In	32 kHz Crystal (optional)
12	SXTAL1	In	32 kHz Crystal (optional)
19	VCC	Pwr	+1.7 to +3.6VDC input 1
A,B,C,D,E,F,7,9,20	GND	Pwr	Electrical Ground
1,2,3,11	RESERVED	N/A	Connect to Ground
4,5,6,8	RESERVED	N/A	Leave Unconnected

Table 3 – Pin Descriptions

Note 1: An external capacitor for V_{CC} is not strictly required, however a 1μF - 4.7μF ceramic capacitor is recommended.

7. Electrical Specifications

7.1. Absolute Maximum Ratings

Symbol	Parameter	Min.	Max.	Unit
V_{CC_MAX}	Voltage on supply pin	-0.3	3.9	V
V_{IO_MAX}	Voltage on SXTAL pins	-0.3	1.4	V
T_S	Storage Temperature Range	-40	125	°C
$V_{ESD-HBM}$	Electrostatic discharge voltage	-2.0	2.0	kV

Table 4 – Absolute Maximum Ratings

7.2. Operating Conditions

Symbol	Parameter	Min.	Max.	Unit
V_{CC}	Operating supply voltage	1.7	3.6	V
T_A	Operating Ambient Temperature Range	-40	85	°C

Table 5 – Operating Conditions

7.3. SPI Interface

The application controller interface (ACI) uses a standard SPI slave interface as the transport layer on five physical wires:

- 2 control wires (clock and slave select)
- 2 data wires with serial shift-out (MOSI and MISO) in full duplex
- 1 wire to indicate data availability from the slave

All the SPI pins have an internal pull-down except for the SPI_CS that has a pull-up. All the SPI pins, except the SPI_CS, are in high impedance state during the low-power states. The SPI_IRQ pin requires an external pull-down resistor.

Symbol	Parameter	Min.	Typ.	Max.	Unit
F_{MAX}	SPI Clock Max Frequency			8	MHz
T_{RISE}	Rise Time	5	-	19	ns
T_{FALL}	Fall Time	6	-	22	ns
V_{IH}	Input High Voltage	$0.65 \times V_{CC}$	-	V_{CC}	V
V_{IL}	Input Low Voltage	V_{SS}	-	$0.35 \times V_{CC}$	V
V_{OH}	Output High Voltage ($V_{CC} = 3.3V$)	2.4	-	-	V
V_{OL}	Output Low Voltage ($V_{CC} = 3.3V$)	-	-	0.4	V
R_{PU}	Pull-up Resistance	11	13	16	k Ω
R_{PD}	Pull-down Resistance	11	13	16	k Ω

Table 6 – SPI Interface

7.4. Clocks

The BMD-100 integrates two low-speed frequency oscillators (LSOSC) and two high-speed (32 MHz) frequency oscillators (HSOSC).

The primary high frequency clock is a 32 MHz crystal oscillator. There is also a fast starting 12 MHz ring oscillator that provides the clock while the crystal oscillator is starting up. Frequency tolerance of the high-speed crystal is ± 30 ppm.

The low frequency clock is used in Low Power mode and can be supplied either by a 32.7kHz oscillator that uses an external crystal and guarantees up to ± 50 ppm frequency tolerance, or by a ring oscillator with maximum ± 500 ppm frequency tolerance, which does not require any external components.

32.768 kHz Crystal Specification Requirements

Symbol	Parameter	Typ.	Max.	Unit
f_{nom}	Crystal frequency	32.768	-	kHz
$F_{tol, BLE}$	Frequency tolerance	-	± 50	ppm
P_D	Load Capacitance	-	0.1	μW

Table 7 - 32.768 kHz Crystal

32.768 kHz Oscillator Comparison

Symbol	Parameter	Typ.	Max.	Unit
f_{nom}	Crystal frequency	37.4	-	kHz
$F_{tol, BLE}$	Frequency tolerance	-	± 500	ppm

Table 8 - 32.768 kHz Oscillator

7.5. Note

Additional electrical characteristics and current consumption data can be found on the BlueNRG-MS datasheet provided by STMicroelectronics at www.st.com.

8. Application controller interface

The application controller interface is based on a standard SPI module with transfer rates up to 8 Mb/s. The application controller interface defines a software protocol providing functions to access all the services offered by the layers of the embedded Bluetooth stack. The ACI commands are described in the BlueNRG-MS ACI command interface document provided by STMicroelectronics at www.st.com.

9. Mechanical Data

9.1. Module Dimensions

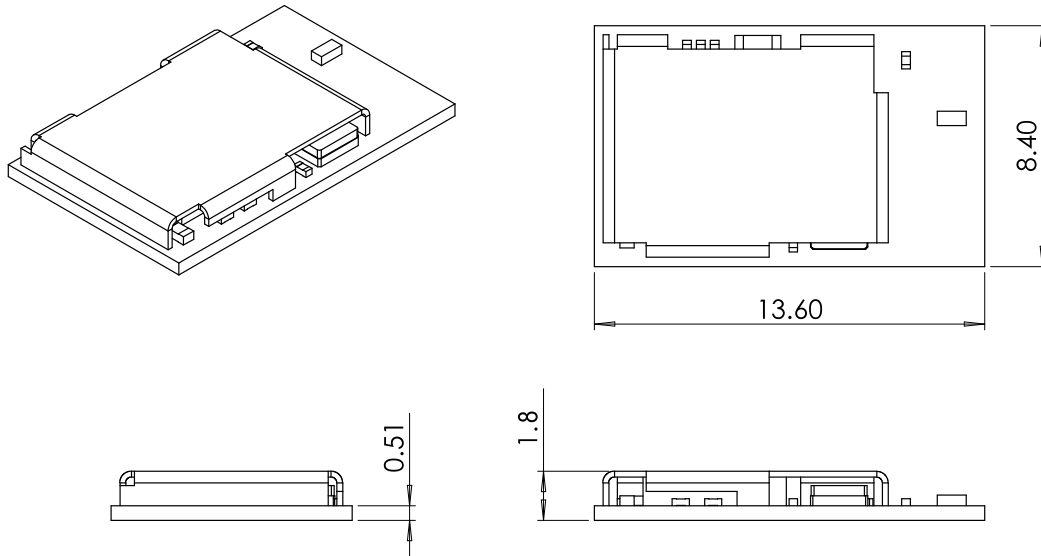

Figure 4- Module Dimensions

(All dimensions are in mm)

9.2. Recommended PCB Land Pad

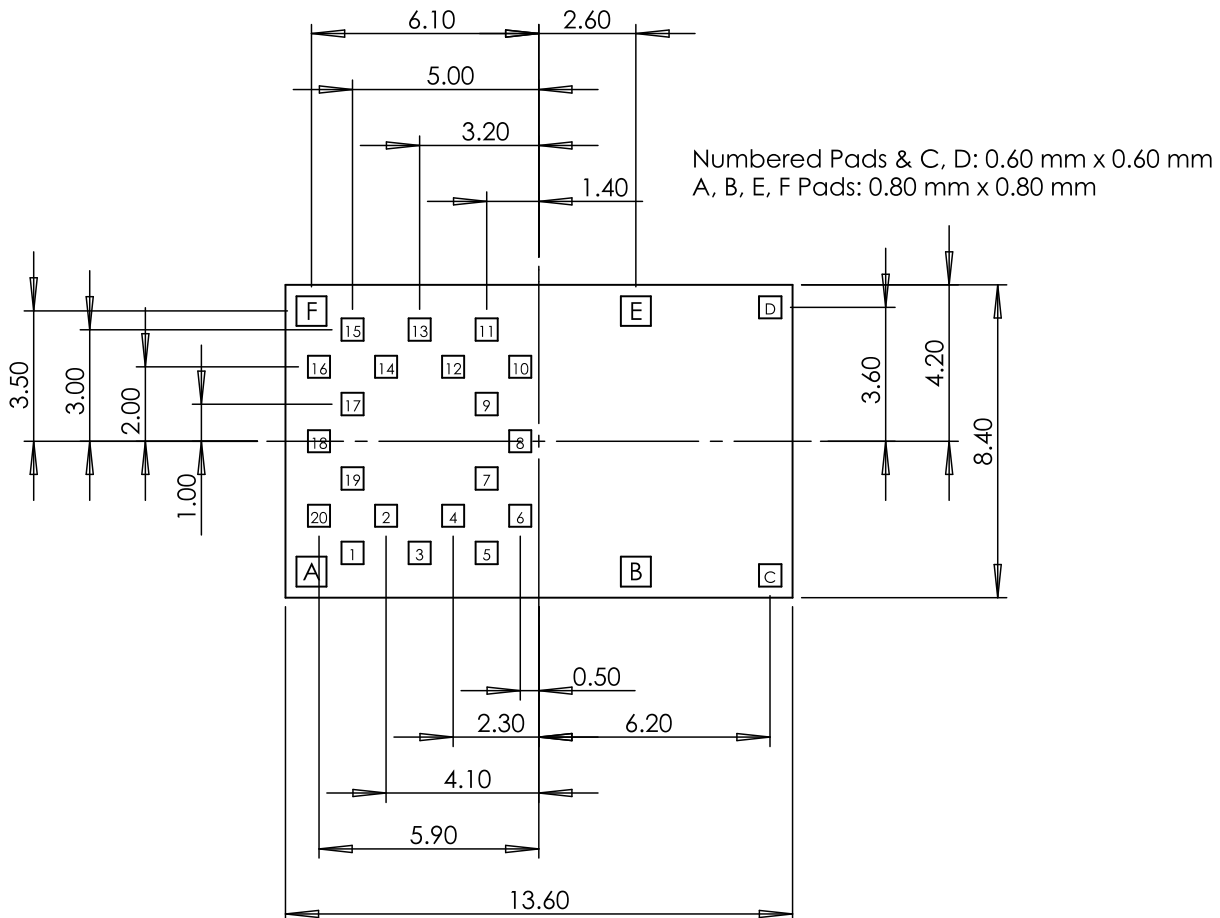

Figure 5- Module Dimensions

(All dimensions are in mm)

10. Module Marking

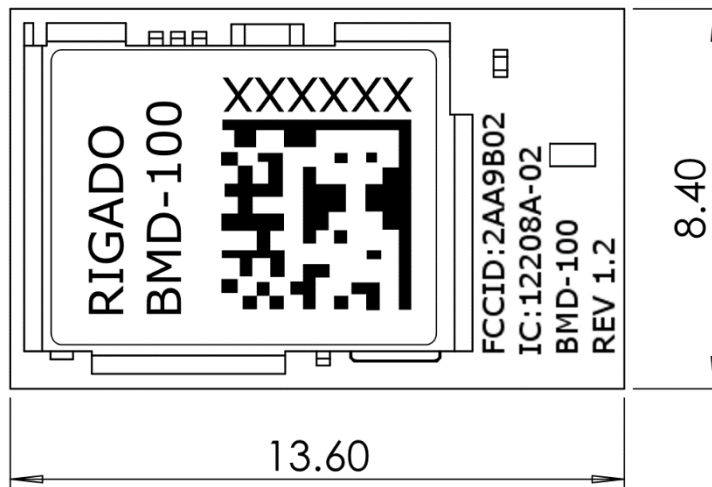

Figure 6 – Module Marking – Rev A

11. RF Design Notes

11.1. Recommended RF Layout & Ground Plane

The integrated ceramic chip antenna requires a suitable ground plane to radiate effectively. Reducing the ground plane from that shown in figure 7 will reduce the effective radiated power.

The BMD-100 module should be placed at the edge of the ground plane with the antenna side towards the edge. Place a copper keep-out under the antenna (area shown in red). The area under the keep-out and extending out from the edge of the ground plane should be kept clear of copper and other metal. The BMD-100 uses a Johanson Technology 2450AT07A0100 chip antenna. Additional information on the antenna can be acquired from www.johansontechnology.com.

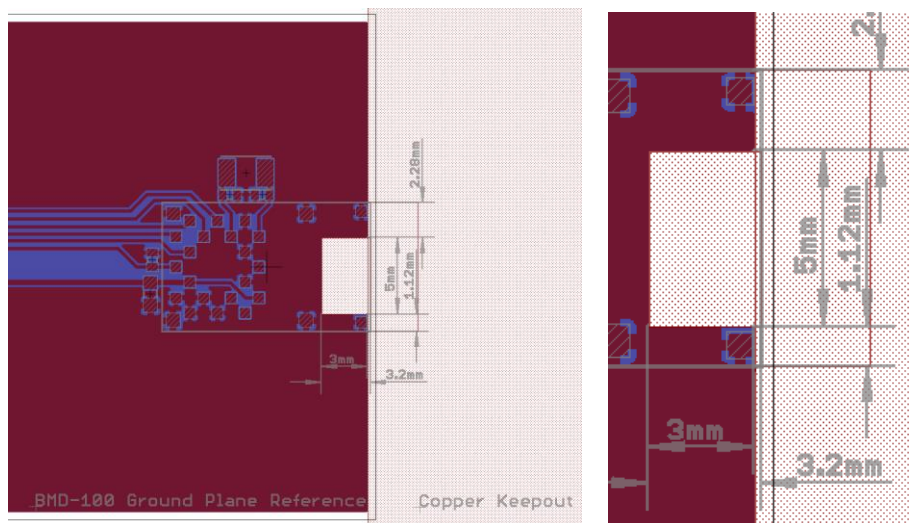

Figure 7- Recommended RF Layout

11.2. Mechanical Enclosure

Care should be taken when designing and placing the module into an enclosure. Metal should be kept clear from the antenna area, both above and below. Any metal around the module can negatively impact RF performance.

The module is designed and tuned for the antenna and RF components to be in free air. Any potting, epoxy fill, plastic overmolding, or conformal coating can negatively impact RF performance and must be evaluated by the customer.

12. Evaluation Boards

Rigado has developed a Nucleo-compatible shield for the BMD-100 that provides a complete development solution for Bluetooth 4.1 LE.

13. Regulatory Statements

13.1. FCC Statement:

This device has been tested and found to comply with part 15 of the FCC rules. These limits are designed to provide reasonable protection against harmful interference in a residential installation. This equipment generates, uses and can radiate radio frequency energy and, if not installed and used in accordance with the instructions, may cause harmful interference to radio communications. However, there is no guarantee that interference will not occur in a particular installation. If this equipment does cause harmful interference to radio or television reception, which can be determined by turning the equipment off and on, the user is encouraged to try to correct the interference by one or more of the following measures:

- Reorient or relocate the receiving antenna.
- Increase the separation between the equipment and the receiver
- Connect the equipment into an outlet on a circuit different from that to which the receiver is connected.
- Consult the dealer or an experienced radio/TV technician for help.

Operation is subjected to the following two conditions: (1) This device may no cause harmful interference, and (2) this device must accept any interference received, including interference that may cause undesired operation. Note: Modification to this product will void the user's authority to operate this equipment.

Note: Modification to this product will void the users' authority to operate this equipment.

13.2. FCC Important Notes:

(1) FCC Radiation Exposure Statement

This equipment complies with FCC RF radiation exposure limits set forth for an uncontrolled environment. This transmitter must not be co-located or operating in conjunction with any other antenna or transmitter. This equipment complies with Part 15 of the FCC Rules. Operation is subject the following two conditions:

- (1) This device may not cause harmful interference, and
- (2) This device must accept any interference received, including interference that may cause undesired operation.

The devices must be installed and used in strict accordance with the manufacturer's instructions as described in the user documentation that comes with the product.

Caution!

The manufacturer is not responsible for any radio or TV interference caused by unauthorized modifications to this equipment. Such modification could void the user authority to operate the equipment.

(2) Co-location Warning:

This device and its antenna(s) must not be co-located or operating in conjunction with any other antenna or transmitter.

(3) OEM integration instructions :

This device is intended only for OEM integrators under the following conditions:

The transmitter module may not be co-located with any other transmit or antenna. The module shall be only

used with the integral antenna(s) that has been originally tested and certified with this module.

As long as the two (2) conditions above are met, further transmitter testing will not be required. However, the OEM integrator is still responsible for testing their end-product for any additional compliance requirements with this module installed (for example, digital device emission, PC peripheral requirements, etc.)

(4) OEM integration instructions :

In the event that these conditions cannot be met (for example certain laptop configuration or co-location with another transmitter), then the FCC authorization for this module in combination with the host equipment is no longer considered valid and the FCC ID of the module cannot be used on the final product. In these and circumstance, the OEM integrator will be responsible for re-evaluating the end product (including the transmitter) and obtaining a separate FCC authorization.

(5) End product labeling :

The final end product must be labeled in a visible area with the following: “Contains **FCC ID: 2AA9B02**”. Any similar wording that expresses the same meaning may be used.

The FCC Statement below should also be included on the label. When not possible, the FCC Statement should be included in the User Manual of the host device.

“This device complies with part 15 of the FCC rules.

Operation is subject to the following two conditions. (1) This device may not cause harmful interference. (2) This device must accept any interference received, including interference that may cause undesired operation. “

(6) Information that must be placed in the end user manual :

The OEM integrator has to be aware not to provide information to the end user regarding how to install or remove this RF module in the user’s manual of the end product which integrates this module. The end user manual shall include all required regulatory information/warning as show in this manual.

13.3. IC Statement:

This device complies with Industry Canada licence-exempt RSS standard(s). Operation is subject to the following two conditions: (1) this device may not cause interference, and (2) this device must accept any interference, including interference that may cause undesired operation of the device.

Le présent appareil est conforme aux CNR d'Industrie Canada applicables aux appareils radio exempts de licence. L'exploitation est autorisée aux deux conditions suivantes : (1) l'appareil ne doit pas produire de brouillage, et (2) l'utilisateur de l'appareil doit accepter tout brouillage radioélectrique subi, même si le brouillage est susceptible d'en compromettre le fonctionnement.

RF exposure warning: The equipment complies with RF exposure limits set forth for an uncontrolled environment. The antenna(s) used for this transmitter must not be co-located or operating in conjunction with any other antenna or transmitter.

Avertissement d'exposition RF: L'équipement est conforme aux limites d'exposition aux RF établies pour un incontrôlés environnement. L'antenne (s) utilisée pour ce transmetteur ne doit pas être co-localisés ou onctionner en conjonction avec toute autre antenne ou transmetteur .

13.4. IC Important Notes:

1. The OEM integrator has to be aware not to provide information to the end user regarding how to install or remove this RF module in the user manual of the end product.

The user manual provided by OEM integrators for end users must include the following information in a prominent location.

2. To comply with IC RF exposure compliance requirements, the antenna used for this transmitter must not be co-located or operating in conjunction with any other antenna or transmitter, except in accordance with IC multi-transmitter product procedures.

3. The final system integrator must ensure there is no instruction provided in the user manual or customer documentation indicating how to install or remove the transmitter module except such device has implemented two-ways authentication between module and the host system.

4. The host device shall be properly labeled to identify the module within the host device. The final end product must be labeled in a visible area with the following: "Contains IC: **12208A-02**".

Any similar wording that expresses the same meaning may be used.

The IC Statement below should also be included on the label. When not possible, the IC Statement should be included in the User Manual of the host device.

"This device complies with Industry Canada licence-exempt RSS standard(s). Operation is subject to the following two conditions: (1) this device may not cause interference, and (2) this device must accept any interference, including interference that may cause undesired operation of the device.

Le présent appareil est conforme aux CNR d'Industrie Canada applicables aux appareils radio exempts de licence. L'exploitation est autorisée aux deux conditions suivantes : (1) l'appareil ne doit pas produire de brouillage, et (2) l'utilisateur de l'appareil doit accepter tout brouillage radioélectrique subi, même si le brouillage est susceptible d'en compromettre le onctionnement."

13.5. CE Regulatory:

This device has been tested and has been found to be complaint against the following standards. OEM integrators should consult with qualified test house to verify all regulatory requirements have been met for their complete device.

From R&TTE Directive 1999/5/EC:

- ETSI EN 300 328 V1.8.1

From Directive 2014/30/EC:

- ETSI EN 301 489-17 V2.2.1
- ETSI EN 301 489-1 V1.9.2
- ETSI EN 61000-3-2: 2006+A2:2009
- ETSI EN 61000-3-3:2013

Declarations of Conformity and supporting test reports are available upon request.

14. Solder Reflow Temperature-Time Profile

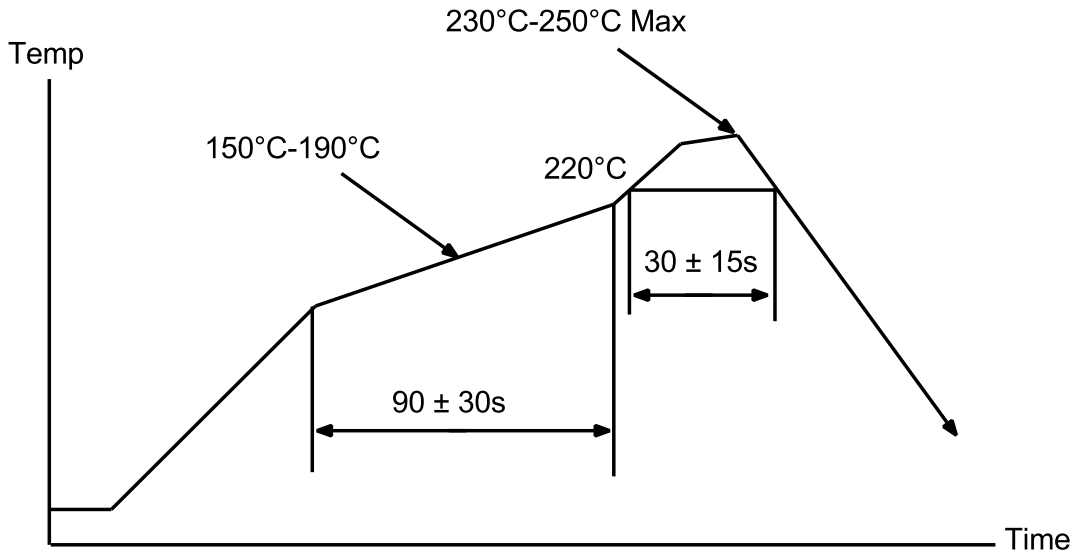

Figure 8 - Reflow Profile for Lead Free Solder

15. Labeling

15.1. Packaging Label

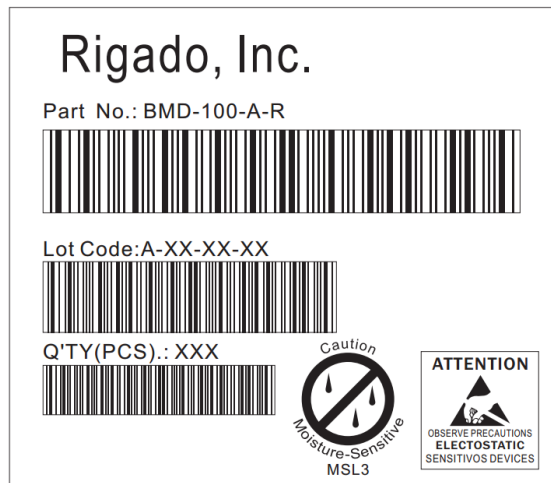

Figure 9 – Packaging Label

16. Cautions

- 1) The guidelines of this document should be followed in order to assure proper performance of the module.
- 2) This product is for use in office, business, and residential applications, but not medical devices.
- 3) This module may short-circuit. If a short circuit can result in serious damage or injury then failsafe precautions should be used. This could be accomplished by redundant systems and protection circuits.
- 4) Supply voltage to the module should not be higher than the specified inputs or reversed. Additionally it should not contain noise, spikes, or AC ripple voltage.
- 5) Avoid use with other high frequency circuits.
- 6) Use methods to eliminate static electricity when working with the module as it can damage the components.
- 7) Contact with wires, the enclosure, or any other objects should be avoided.
- 8) Refer to the recommended pattern when designing for this module.
- 9) If hand soldering is used, be sure to use the precautions outlined in this document.
- 10) This module should be kept away from heat, both during storage and after installation.
- 11) Do not drop or physically shock the module.
- 12) Do not damage the interface surfaces of the module.
- 13) The module should not be mechanically stressed at any time (storage, handling, installation).
- 14) Do not store or expose this module to:
 - Humid or salty air conditions
 - High concentrations of corrosive gasses.
 - Long durations of direct sunlight.
 - Temperatures lower than -40°C or higher than 125°C.

17. Life Support Policy

This product is not designed to be used in a life support device or system, or in applications where there is potential for a failure or malfunction to, directly or indirectly, cause significant injury. By using this product in an application that poses these risks, such as described above, the customer is agreeing to indemnify Rigado for any damages that result.

18. Document History

Revision	Date	Changes / Notes
0.5	1/5/14	Initial Release - Preliminary
0.8	3/10/14	Added regulatory certifications
1.0	7/28/14	Production release
1.1	12/18/17	Updated for consistency

19. Related Documents

STMicroelectronics Documents:

- DM00141263: BlueNRG-MS Datasheet
- DM00162667: BlueNRG-MS Stack ACI User Manual



Компания «ЭлектроПласт» предлагает заключение долгосрочных отношений при поставках импортных электронных компонентов на взаимовыгодных условиях!

Наши преимущества:

- Оперативные поставки широкого спектра электронных компонентов отечественного и импортного производства напрямую от производителей и с крупнейших мировых складов;
- Поставка более 17-ти миллионов наименований электронных компонентов;
- Поставка сложных, дефицитных, либо снятых с производства позиций;
- Оперативные сроки поставки под заказ (от 5 рабочих дней);
- Экспресс доставка в любую точку России;
- Техническая поддержка проекта, помощь в подборе аналогов, поставка прототипов;
- Система менеджмента качества сертифицирована по Международному стандарту ISO 9001;
- Лицензия ФСБ на осуществление работ с использованием сведений, составляющих государственную тайну;
- Поставка специализированных компонентов (Xilinx, Altera, Analog Devices, Intersil, Interpoint, Microsemi, Aeroflex, Peregrine, Syfer, Eurofarad, Texas Instrument, Miteq, Cobham, E2V, MA-COM, Hittite, Mini-Circuits, General Dynamics и др.);

Помимо этого, одним из направлений компании «ЭлектроПласт» является направление «Источники питания». Мы предлагаем Вам помощь Конструкторского отдела:

- Подбор оптимального решения, техническое обоснование при выборе компонента;
- Подбор аналогов;
- Консультации по применению компонента;
- Поставка образцов и прототипов;
- Техническая поддержка проекта;
- Защита от снятия компонента с производства.



Как с нами связаться

Телефон: 8 (812) 309 58 32 (многоканальный)

Факс: 8 (812) 320-02-42

Электронная почта: org@eplast1.ru

Адрес: 198099, г. Санкт-Петербург, ул. Калинина, дом 2, корпус 4, литера А.