

Low Power 3D Magnetic Sensor with I²C Interface

TLV493D-A1B6 3D Magnetic Sensor

3D Magnetic Sensor

Data Sheet

Rev. 1.0, 2016-01-29

Table of Contents

1	Product Description	5
1.1	Target Applications	5
1.2	Features	5
2	Functional Description	6
2.1	General	6
2.1.1	Power Mode Control	6
2.1.2	Sensing Part	7
2.2	Pin Configuration (top view)	8
2.3	Definition of Magnetic Field	8
2.4	Sensitive Area	9
2.5	Application Circuit	10
3	Specification	11
3.1	Absolute Maximum Ratings	11
3.2	Operating Range	11
3.3	Electrical Characteristics	13
3.4	Temperature Measurement (default = activated)	14
4	Interface and Timing Description	15
5	Magnetic Characteristics	17
6	Characteristical	18
7	Package Information	19
7.1	Package Parameters	19
7.2	Package Outlines	19
8	Revision History	22

List of Tables

Table 1	Ordering Information	5
Table 2	TSOP-6 Pin Description and Configuration (see Figure 1).....	8
Table 3	Absolute Maximum Ratings	11
Table 4	ESD Protection (TA = 25°C)	11
Table 5	Operating Range	11
Table 6	Electrical Setup	13
Table 7	Temperature Measurement Characteristics	14
Table 8	Interface and Timing	15
Table 9	Conversion table for 12Bit	16
Table 10	Initial Magnetic Characteristics	17
Table 11	Sensor Drifts.....	17
Table 12	Package Parameters	19

List of Figures

Figure 1	All three Sensitive Directions Bx, By and Bz	5
Figure 2	Block Diagram	6
Figure 3	Pinout	8
Figure 4	Definition of Magnetic Field Direction	8
Figure 5	Center of Sensitive Area	9
Figure 6	Application Circuit with external Power Supply and μC	10
Figure 7	I ² C Timing Specification	15
Figure 8	I _{DD} versus Temperature	18
Figure 9	Image of TLV493D-A1B6 in TSOP-6	19
Figure 10	Footprint PG-TSOP-6-6-5, Reflow Soldering	19
Figure 11	Footprint PG-TSOP-6-6-5, Wave Soldering	20
Figure 12	Package Outlines (all dimensions in mm)	20
Figure 13	Packing (all dimensions in mm)	21

Product Description

1 Product Description

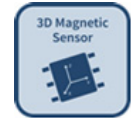

1.1 Target Applications

The 3D magnetic sensor TLV493D-A1B6 offers accurate three-dimensional sensing with extremely low power consumption in a small 6-pin package. With its magnetic field detection in x, y, and z-direction the sensor reliably measures three-dimensional, linear and rotation movements. Applications include joysticks, control elements (white goods, multifunction knobs), or electric meters (anti tampering) and any other application that requires accurate angular measurements or low power consumptions.

The integrated temperature sensor can furthermore be used for plausibility checks.

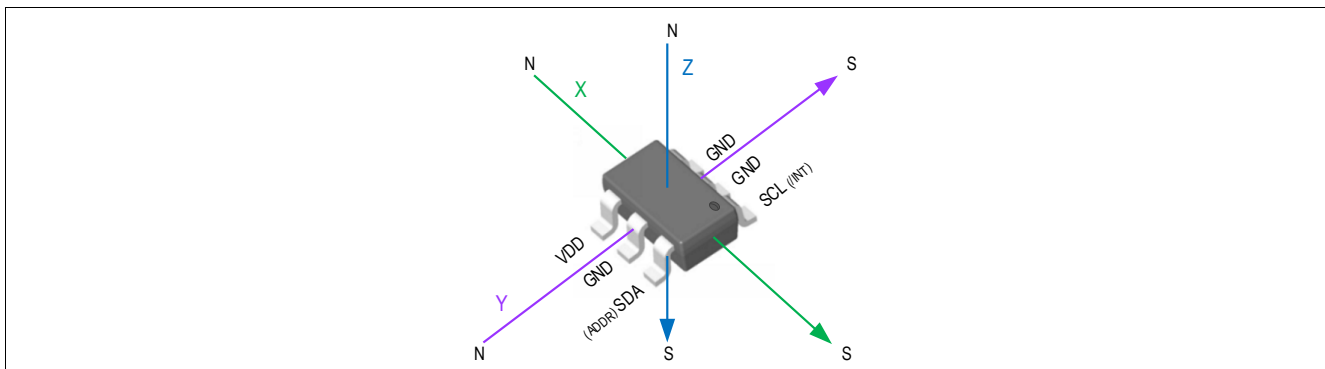

Figure 1 All three Sensitive Directions Bx, By and Bz

1.2 Features

- 3D magnetic sensing
- Very low power consumption = 10µA during operations (10Hz, typ)
- Power down mode with 7nA power consumption
- Digital output via 2-wire based standard I²C interface up to 1 MBit/sec
- 12 bit data resolution for each measurement direction
- Bx, By and Bz linear field measurement up to +-130mT
- Excellent matching of X/Y measurement for accurate angle sensing
- Variable update frequencies and power modes (configurable during operation)
- Supply voltage range= 2.8V...3.5V, Temperature range Tj= -40°C...125°C
- Small, industrial 6 pin TSOP package
- Triggering by external µC possible
- Interrupt signal available to wake up a microcontroller
- Temperature measurement

Table 1 Ordering Information

Product Name	Marking	Ordering Code	Package
3D Magnetic Sensor TLV493D-A1B6	VA (serie) SA (eng. samples)	SP001286056	PG-TSOP-6-6-5

Functional Description

2 Functional Description

2.1 General

Description of the Block diagram and its functions.

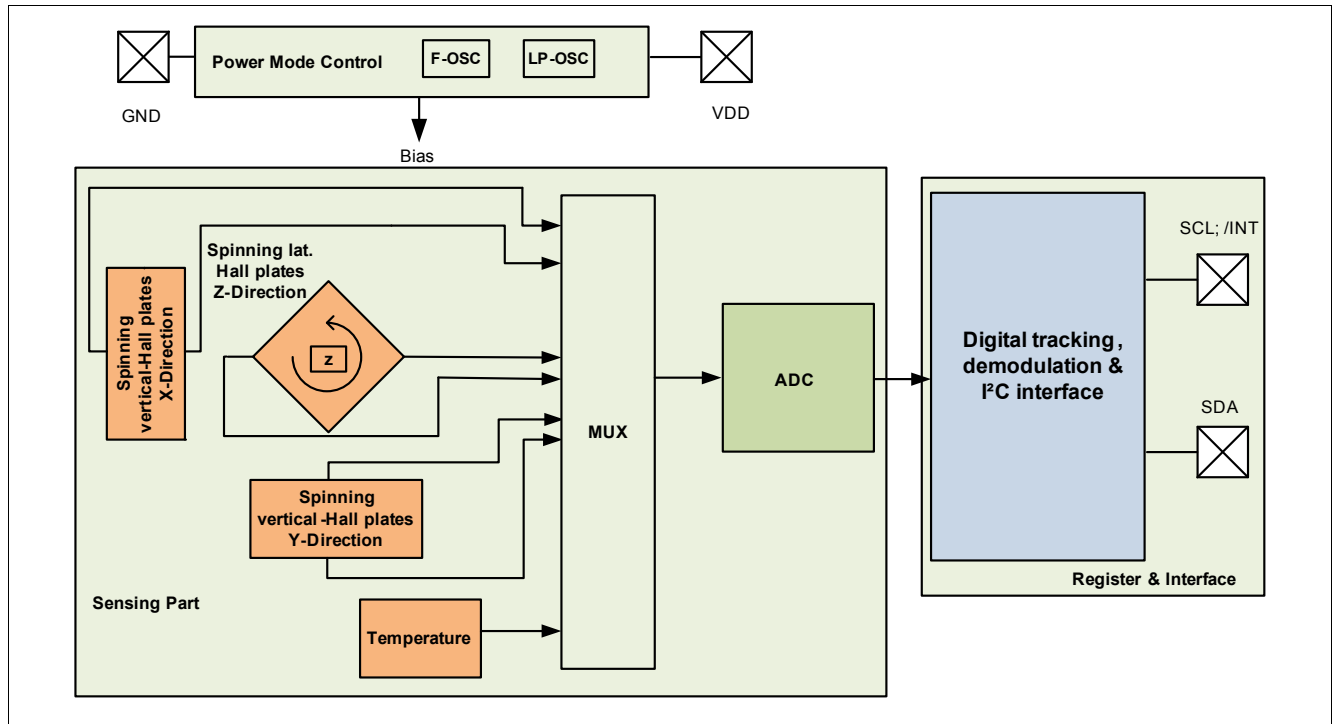

Figure 2 Block Diagram

The IC consists of three main function units containing the following building blocks:

- The power mode control system, containing a low-power oscillator, basic biasing, accurate reset, undervoltage detection and a fast oscillator.
- The sensing part, containing the HALL biasing, HALL probes with multiplexers and successive tracking ADC. Furthermore a temperature sensor is implemented.
- The I²C interface, containing the register file and I/O pads.

2.1.1 Power Mode Control

The power mode control provides the power distribution in the IC, a power-on reset function and a specialized low-power oscillator clock source. Additionally it is handling the start-up behavior.

- On start-up this unit:
 - activates the biasing, provides an accurate reset detector and fast oscillator.
 - interprets the applied voltage level on ADDR pin as logical “0” or “1”. This determines one of two possible I²C bus addresses to access the sensor.
 - sensor enters power down mode (configured via I²C interface).

Note: After supplying the sensor (= power up) the sensor enters the mode power down by default.

Functional Description

- After re-configuration to one of the operating modes a measurement cycle is performed regularly containing of:
 - starts the internal biasing, checks for reset condition and provides the fast oscillator
 - provides the HALL biasing
 - the measurement of the three HALL probe channels sequentially incl. temperature (default = activated)
 - and enters the configured mode again

In any case functions are only executed if the supply voltage is high enough, otherwise the reset circuit will halt the state machine until the level is reached and restarts its operation afterwards. The functions are also restarted if a reset event occurs in between.

2.1.2 Sensing Part

Performs the measurements of the magnetic field in X, Y and Z direction. Each X, Y and Z-HALL probe is connected sequentially to a multiplexer, which is then connected to an Analog to Digital Converter (ADC). Optionally, the temperature is determined as well after the three HALL channels. The current consumption decreases by -25% when temperature measurement is deactivated.

Functional Description

2.2 Pin Configuration (top view)

Figure 3 shows the pinout of the TLV493D-A1B6.

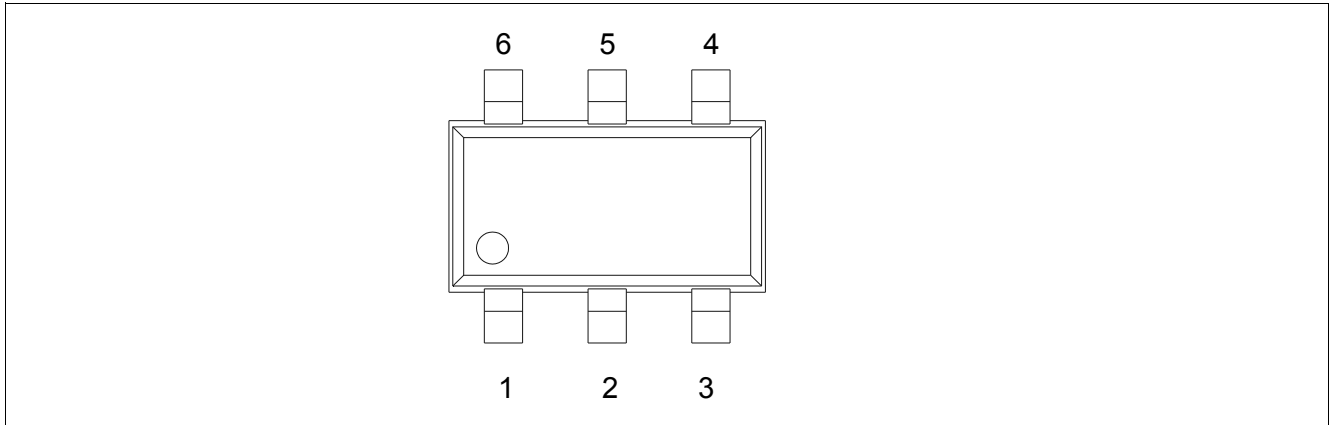

Figure 3 Pinout

Table 2 TSOP-6 Pin Description and Configuration (see Figure 1)

Pin No.	Name	Description
1	SCL /INT	Interface serial clock pin (input) Interrupt pin, signals a finished measurement cycle
2	GND	connect to GND
3	GND	Ground Pin
4	VDD	Supply Pin
5	GND	connect to GND
6	SDA ADDR	Interface serial data pin (input/output), open drain Sensor ID configuration during power up

2.3 Definition of Magnetic Field

A positive field is considered as South-Pole facing the corresponding Hall element.

Figure 4 shows the definition of the magnetic directions X, Y, Z of the TLV493D-A1B6.

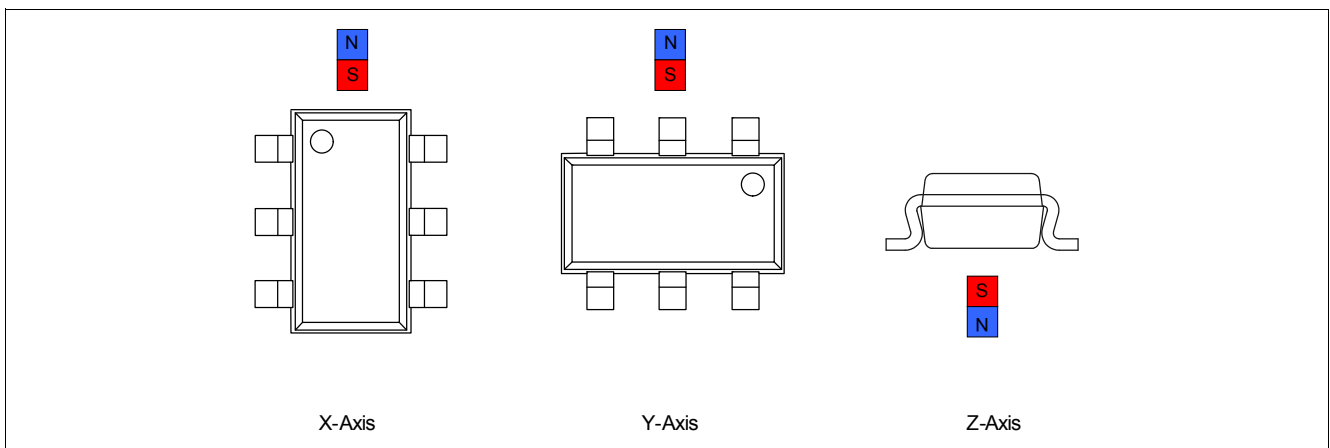

Figure 4 Definition of Magnetic Field Direction

Functional Description

2.4 Sensitive Area

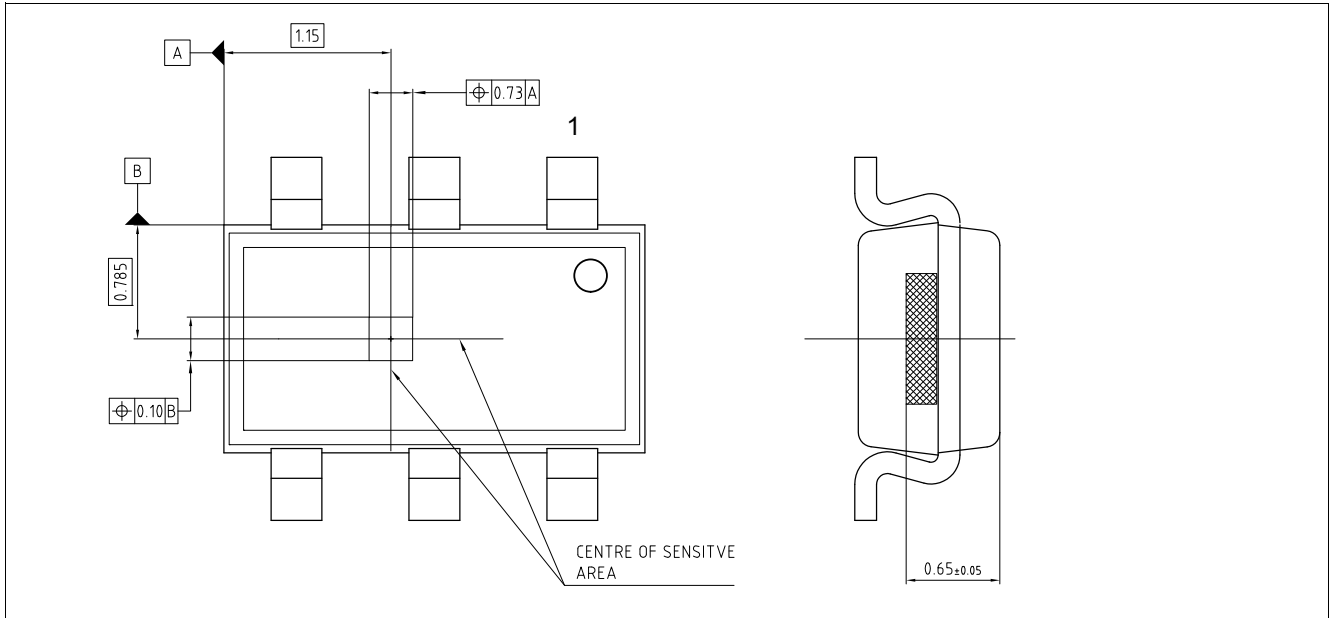

Figure 5 Center of Sensitive Area

Functional Description

2.5 Application Circuit

The use of an interrupt line is optional, but highly recommended to ensure proper and efficient readout of the sensor data.

The pull-up resistors R_1 & R_2 of the I²C bus have to be set in a way to keep the rise- and fall time specification of the interface bus parameters (see specification section) with the parasitic capacitive load of the actual setup.

The serial resistances R between SDA /SCL & Pull up R_1/R_2 may be used to avoid reflections on longer bus lines causing ground bouncing on sensor side and communication issues.

The series resistance R between and the SCL μ C pin and the pull up resistor R_2 together with the capacitance C_2 to ground may provide additional EMC filtering if required.

Please note: too small resistive values for $R_{1/2}$ have to be prevented to avoid unnecessary power consumption during interface transmissions, especially for low-power applications. The additional capacitor C_2 on the SCL line will limit the maximum possible bitrate on the bus.

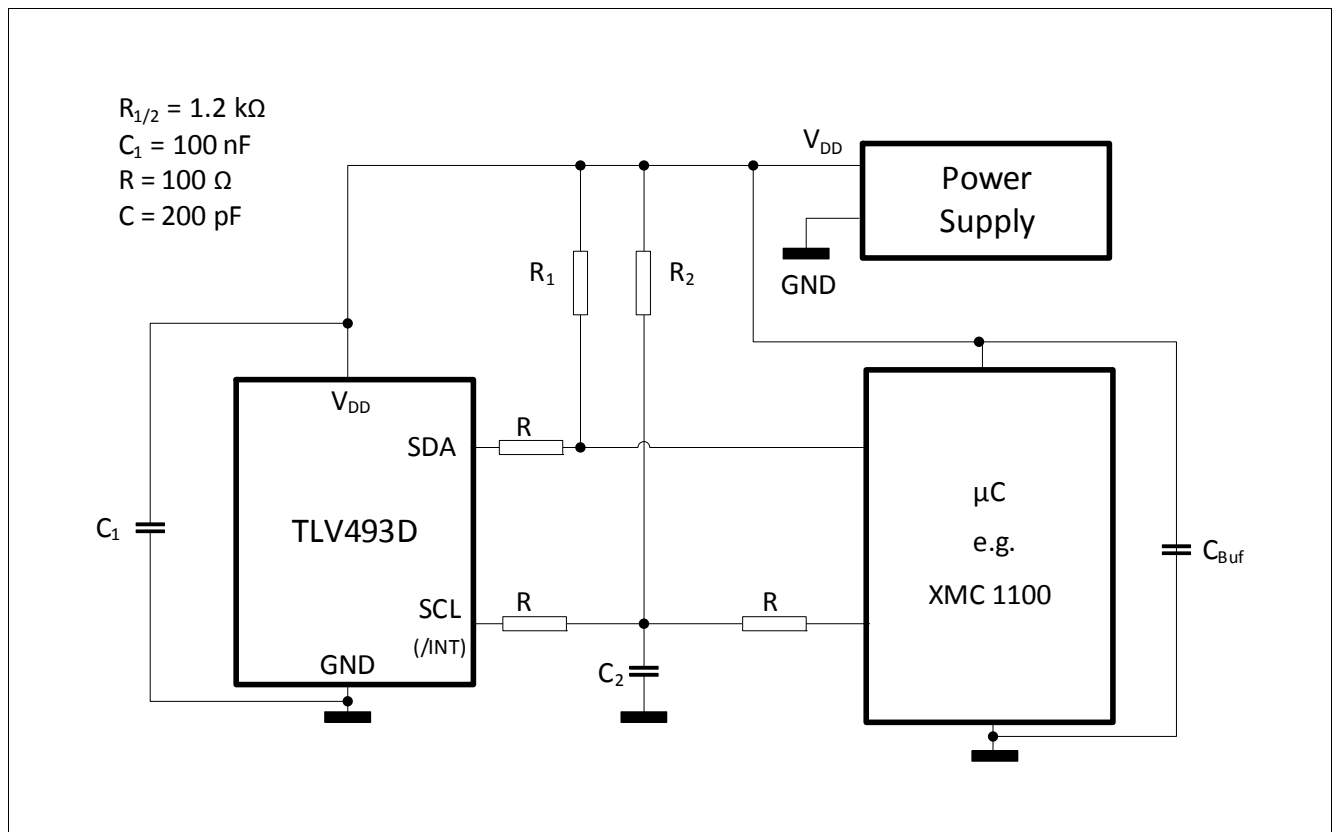

Figure 6 Application Circuit with external Power Supply and μ C

For additional EMC precaution in harsh environments, C_1 may be implemented by two 100nF capacitors in parallel, which should be already given by C_{buf} near the μ C and/or power supply.

Specification

3 Specification

3.1 Absolute Maximum Ratings

Attention: Stresses above those listed under “Absolute Maximum Ratings” may cause permanent damage to the device. This is a stress rating only and functional operation of the device at these or any other conditions above those indicated in the operational sections of this specification is not implied. Furthermore, only single error cases are assumed. More than one stress/error case may also damage the device.

Exposure to absolute maximum rating conditions for extended periods may affect device reliability. During absolute maximum rating overload conditions the voltage on VDD pins with respect to ground (VSS) must not exceed the values defined by the absolute maximum ratings.

Table 3 Absolute Maximum Ratings

Parameter	Symbol	min	typ	max	Unit	Note/Condition
Junction temperature	T_j	-40	–	125	°C	–
Voltage on VDD	V_{DD}	-0.3	–	3.5	V	–
Magnetic field	B_{max}	–	–	1	T	–
Voltage range on any pin to GND		-0.1	–	3.5	V	open-drain outputs are not current limited

Table 4 ESD Protection¹⁾ (TA = 25°C)

Parameter	Symbol	Values			Unit	Note or Test Condition
		Min.	Typ.	Max.		
ESD voltage (HBM) ²⁾	V_{ESD}	-1.5		+1.5	kV	R = 1.5 kΩ, C = 100 pF
ESD voltage (CDM) ³⁾				750	V	for corner pins
					500	V

- 1) Characterization of ESD is carried out on a sample basis, not subject to production test.
- 2) Human Body Model (HBM) tests according to ANSI/ESDA/JEDEC JS-001.
- 3) Charged Device Model (CDM), ESD susceptibility according to JEDEC JESD22-C101.

3.2 Operating Range

Table 5 Operating Range

Parameter	Symbol	min	typ	max	Unit	Note/Condition
Operating temperature	T_j	-40	–	125	°C	$T_j = T_a + 3^\circ\text{C}$ as worst case assumption
I ² C bit clock frequency	f	100	400	1000	kHz	Assume a tolerance of <10%
Supply voltage	V_{DD}	2.8	3.3	3.5	V	see Note below
Reset level	V_{res}	–	2.2	–	V	see Note below

Specification

Note: To provide these ultra low power consumption figures, the chip does not use a classic (and current consuming) reset concept. The implemented reset focus is on ensuring a proper supply for the ADC operation only (so it inhibits the ADC reliably until the sensor supply is high enough). Thus, the sensor rely on a proper supply ramp incl. 3.7mA current consumption during power-on to ensure it is initialized correctly, typically a monotonic rise of Vdd from zero to 3.3V within less than 10 μ s and without over/undershoots larger than 300mV. If such a supply can not be provided, the I²C reset feature of the sensor shall be used by the μ C after power-up. If supply monitoring is used in the system (e.g. brown-out detector etc.) it is also recommended to use the I²C reset of the sensor upon events detected by this monitor.

Specification

3.3 Electrical Characteristics

Note: All specification parameters refer to 3.3V \pm 5% nominal supply V_{DD} on the pins directly. Typical values refer to 25°C and to 3.3V \pm 5% nominal supply.

Table 6 Electrical Setup

Parameter	Symbol	min	typ	max	Unit	Note/Condition
Supply current ¹⁾	I_{DD}	–	7	100	nA	power down mode (default after power on), all off
		–	10	–	μ A	ultra low power mode
		–	80	–	μ A	low power mode
Average operating current	I_{DD_op}	–	3.7	–	mA	peak during ADC measurements for about 270 μ s ^{2) 3)}
Input voltage low threshold	V_{IL}	–	–	20	% V_{DD}	all input pads
Input voltage high threshold	V_{IH}	70	–	–	% V_{DD}	all input pads
Input voltage hysteresis threshold		5	–	–	% V_{DD}	all input pads
Output voltage low level @ 3 mA load	V_{OL}	–	–	0.4	V	all output pads, static load
Fall time SDA/SCL signal ⁴⁾	t_{FALL}	–	0.25 ⁵⁾	0.3	μ s	0.3 μ s for 400kHz mode (or may require less C load)
Rise time SDA/SCL signal ⁴⁾	t_{RISE}	–	0.5 ⁵⁾	–	μ s	R=1.2k
Output high level	V_{OH}	–	V_{DD}	–	V	given by ext. pull-up resistor

- 1) Average values
- 2) During power down mode the current consumption is about 7nA
- 3) Current at Pull ups needs to be considered for power supply dimensioning, consider minimum 10mA for the power supply for the sensor only
- 4) Dependent on used R-C-combination
- 5) For given AppCircuit; Capacitive load (parasitics and discrete caps used) for each bus line = 200pF (SDA, SCL)

Note: The average supply current I_{DD} in the low power modes and I²C triggered mode will decrease by about 25% when the temperature measurement is disabled.

Specification

3.4 Temperature Measurement (default = activated)

Table 7 Temperature Measurement Characteristics

Parameter	Symbol	min	typ	max	Unit	Note/Condition
Digital value @ 25°C ¹⁾		–	340	–	LSB	–
Resolution 12bit		–	1.1	–	°C/LSB	–
Accuracy		–	±10	–	°C	–

1) Theoretical possible measurement range from -50°C to 150°C

Interface and Timing Description

4 Interface and Timing Description

This chapter refers to how to set the boundary conditions in order to establish a proper interface communication.

Table 8 Interface and Timing

Parameter	Symbol	min	typ	max	Unit	Note/Condition
Update rate X, Y, Z		-	3.3	-	kHz	max. ADC conversion rate
Update rate (all axis), ultra low p.		-	10	-	Hz	int. triggered
Update rate (all axis), low p.		-	100	-	Hz	int. triggered
End-of-Conversion /INT pulse	t_{INT}	-	1.5	-	μs	low-active (when activated)
Internal clock accuracy	t_{clk_E}	-25	-	+25	%	all above timing parameters
Allowed I ² C bit clock frequency	f_{I2C_clk}		400	1000	kHz	400kHz is I ² C fast mode
Low period of SCL clock	t_L	0.5	-	-	μs	1.3 μs for 400kHz mode
High period of SCL clock	t_H	0.4	-	-	μs	0.6 μs for 400kHz mode
SDA fall to SCL fall hold time (hold time start condition to clock)	t_{STA}	0.4	-	-	μs	0.6 μs for 400kHz mode
SCL rise to SDA rise su. time (setup time clock to stop condition)	t_{STOP}	0.4	-	-	μs	0.6 μs for 400kHz mode
SDA rise to SDA fall hold time (wait time from stop to start cond.)	t_{WAIT}	0.4	-	-	μs	0.6 μs for 400kHz mode
SDA setup before SCL rising	t_{SU}	0.1	-	-	μs	-
SDA hold after SCL falling	t_{HOLD}	0	-	-	μs	-

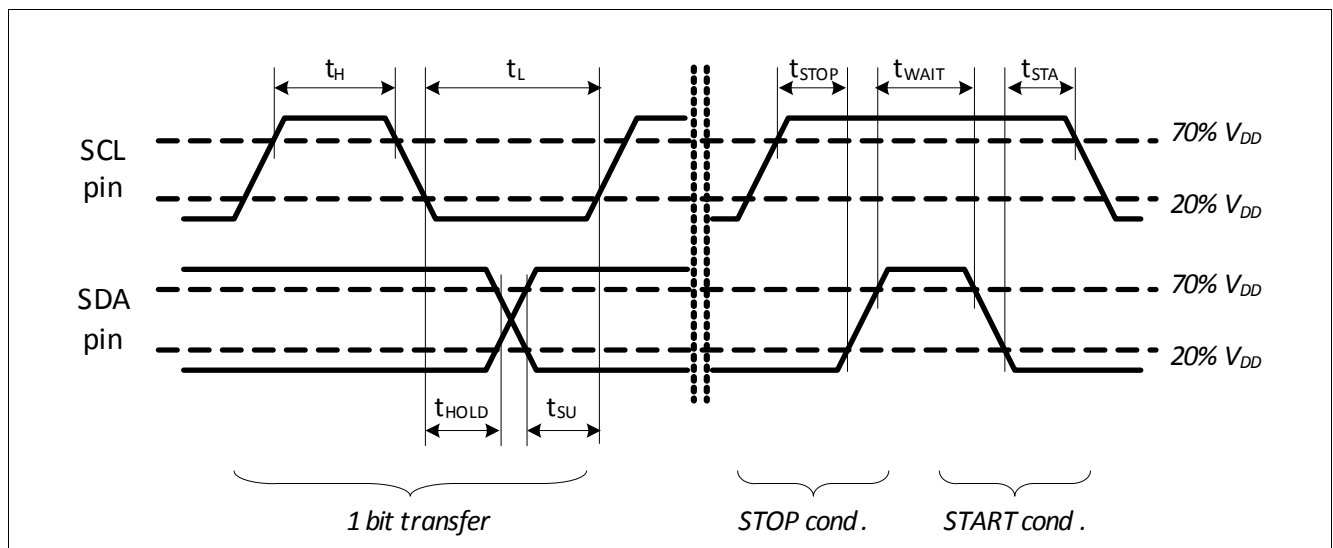

Figure 7 I²C Timing Specification

Interface and Timing Description

Managing correct sensor read outs by the μ C:

This sensor does not incorporate shadow-buffers for readout. Thus, it is mandatory to read the sensor data not during a running conversion to avoid corrupted reads. Ideally, the /INT feature is enabled together with the low-power or ultra-low power mode and the μ C reads the data after the /INT pulse was asserted by the sensor. Furthermore, the readout needs to be finished before a new conversion is started and the /INT will be asserted again (if the readout is finished 1 ms before a new /INT pulse, this will be sufficient).

Conversion register value to magnetic field and temperature value:

The conversion is realized by the two's complement. Please use following table for transformation:

Table 9 Conversion table for 12Bit

	MSB	Bit11	Bit10	Bit9	Bit8	Bit7	Bit6	Bit5	Bit4	Bit3	Bit2	LSB
	-2048	1024	512	256	128	64	32	16	8	4	2	1
e.g.	1	1	1	1	0	0	0	0	1	1	1	1

Example for 12Bit read out: 1111 0000 1111: $-2048 + 1024 + 512 + 256 + 0 + 0 + 0 + 0 + 8 + 4 + 2 + 1 = -241$ LSB

Calculation to mT: $-241 \text{ LSB} * 0.098 \text{ mT/LSB} = -23.6\text{mT}$

For further information and a detailed I²C bitmap please refer to user manual.

Magnetic Characteristics

5 Magnetic Characteristics

Table 10 Initial Magnetic Characteristics¹⁾

Values for 25°C, 0h and $V_{DD} = 3.3V$

Parameter	Symbol	min	typ	max	Unit	Note/Condition
Usable magnetic linear range	B_{xyz_LIN}	-	± 130	-	mT	Bx, By and Bz
Offset		-1	± 0.2	+1	mT	Bx, By and Bz
Sensitivity		-	10.2	-	LSB ₁₂ / mT	Bx, By and Bz; (12bit)
Resolution 12-bit readout ²⁾	Res ₁₂	-	98	-	μT / LSB ₁₂	-
Resolution 8-bit readout ²⁾	Res ₈	-	1.56	-	mT/ LSB ₈	-
Magnetic noise (rms)		-	0.1		mT	rms = 1 sigma
Magnetic hysteresis		-	1	-	LSB ₁₂	due to quantization effects

1) Magnetic test on wafer level. It is assumed that initial variations are stored and compensated in the external μC during module test and calibration.

2) Resolution is calculated as 1/Sensitivity (and multiplied by 16 for 8-bit value)

Table 11 Sensor Drifts¹⁾

Values for $V_{DD} = 3.3V \pm 5\%$, $T_j = -40$ to 125 °C, static magnetic field within usable linear range

Parameter	Symbol	min	typ	max	Unit	Note/Condition
Sensitivity drift		-	± 20	-	%	Bx, By and Bz
Offset drift		-1	± 0.2	+1	mT	Bx, By and Bz; @ 0mT
X to Y magnetic matching drift ²⁾		-	± 5	-	%	
X/Y to Z magnetic matching drift ²⁾		-	± 20	-	%	
Temperature compensation ³⁾		-	0	-	ppm/K	Bx, By and Bz
DNL (Differential Non Linearity) ¹⁾		-	± 5	-	LSB ₁₂	Bx, By and Bz
INL (Integral Non Linearity) ¹⁾		-	0.1	-	%FSR ⁴⁾	Bx, By and Bz

1) Not subject to production test, verified by design/characterization. Drifts are changes from the initial characteristics due to external influences.

2) The matching is defined for sensitivity values of Bx (=X), By (=Y) and Bz (=Z) as:

X/Y matching: $2 \cdot (X-Y)/(X+Y)$ [in %]

X/Y to Z matching: $2 \cdot (X+Y-2 \cdot Z)/(X+Y+2 \cdot Z)$ [in %]

3) Can be changed by I²C command during operation; further typical values are -2000, -1000, +500 ppm/K

4) The FSR is calculated as $\pm 2048 \cdot Res_{12}$

Characteristical

6 Characteristical

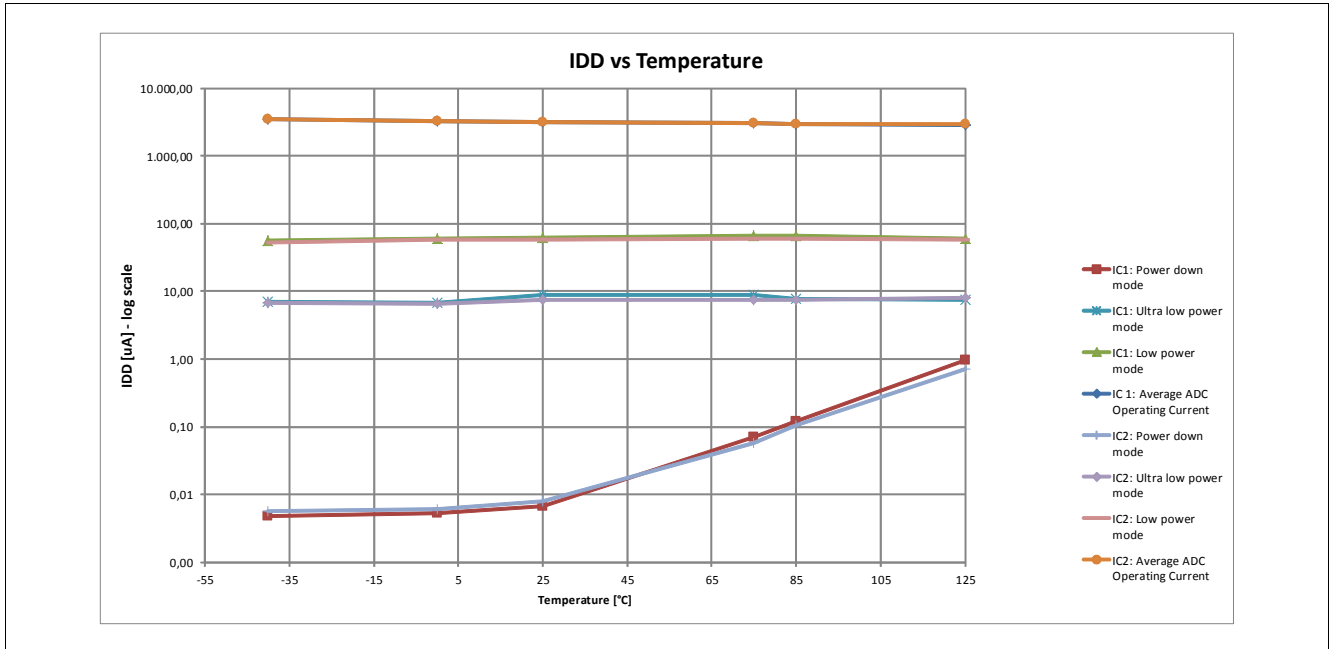

Figure 8 I_{DD} versus Temperature

Package Information

7 Package Information

7.1 Package Parameters

Table 12 Package Parameters

Parameter	Symbol	Limit Values			Unit	Notes
		Min.	Typ.	Max.		
Thermal resistance Junction ambient	R_{thJA}			200	K/W	Junction to air ¹⁾ for PG-TSOP-6-6-5
Thermal resistance Junction lead	R_{thJL}			100	K/W	Junction to lead for PG-TSOP-6-6-5
Soldering moisture level	MSL 1					260°C ²⁾

1) according to Jecdec JESD51-7

2) suitable for reflow soldering with soldering profiles according to JEDEC J-STD-020D.1 (March 2008)

7.2 Package Outlines

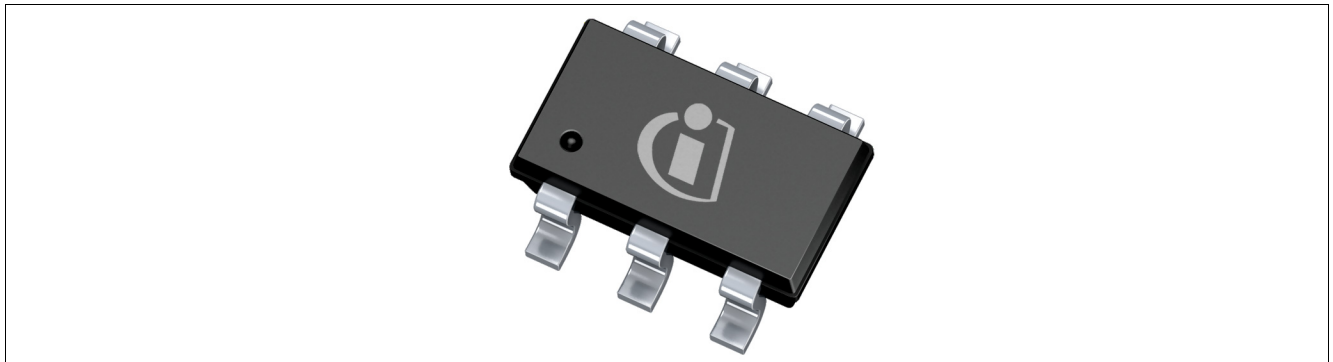

Figure 9 Image of TLV493D-A1B6 in TSOP-6

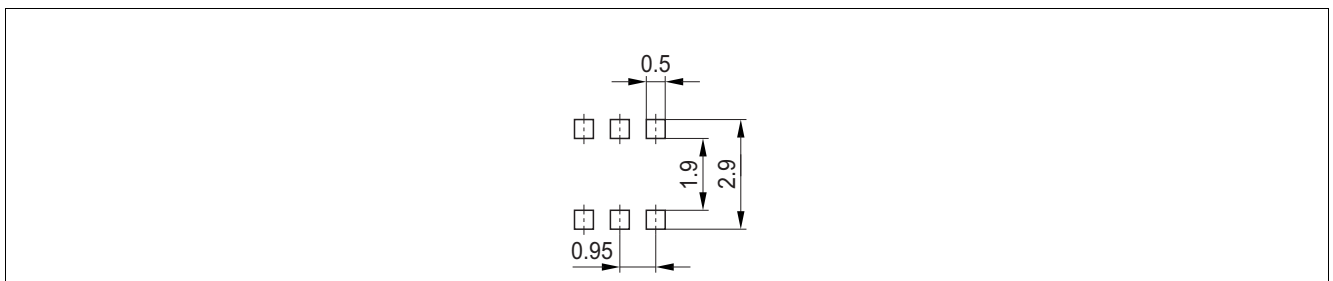

Figure 10 Footprint PG-TSOP-6-6-5, Reflow Soldering

Package Information

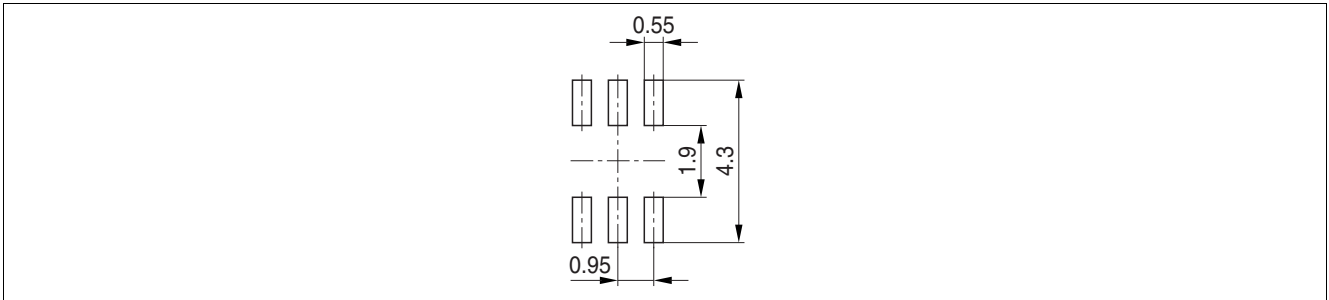

Figure 11 Footprint PG-TSOP-6-6-5, Wave Soldering

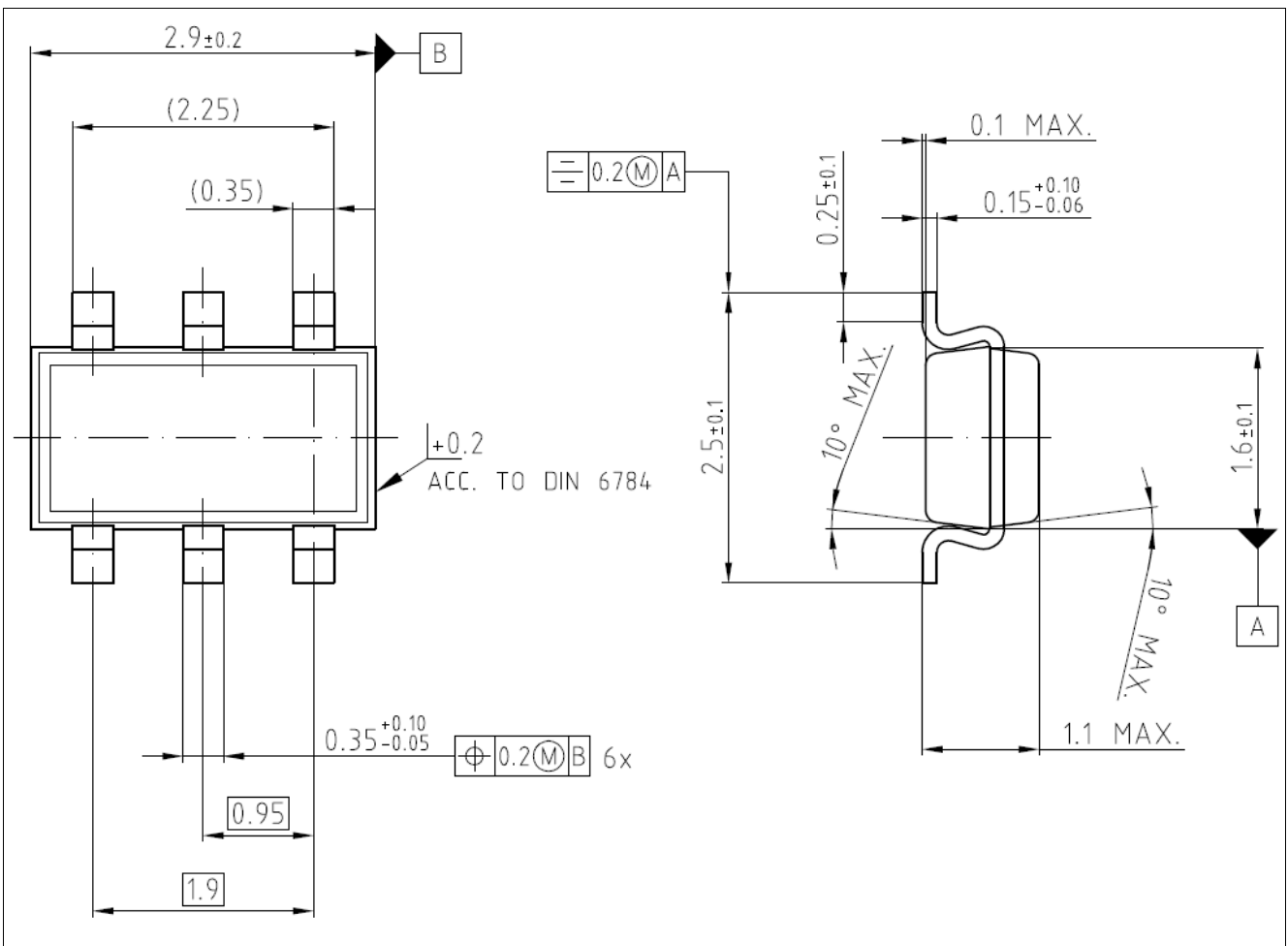

Figure 12 Package Outlines (all dimensions in mm)

Package Information

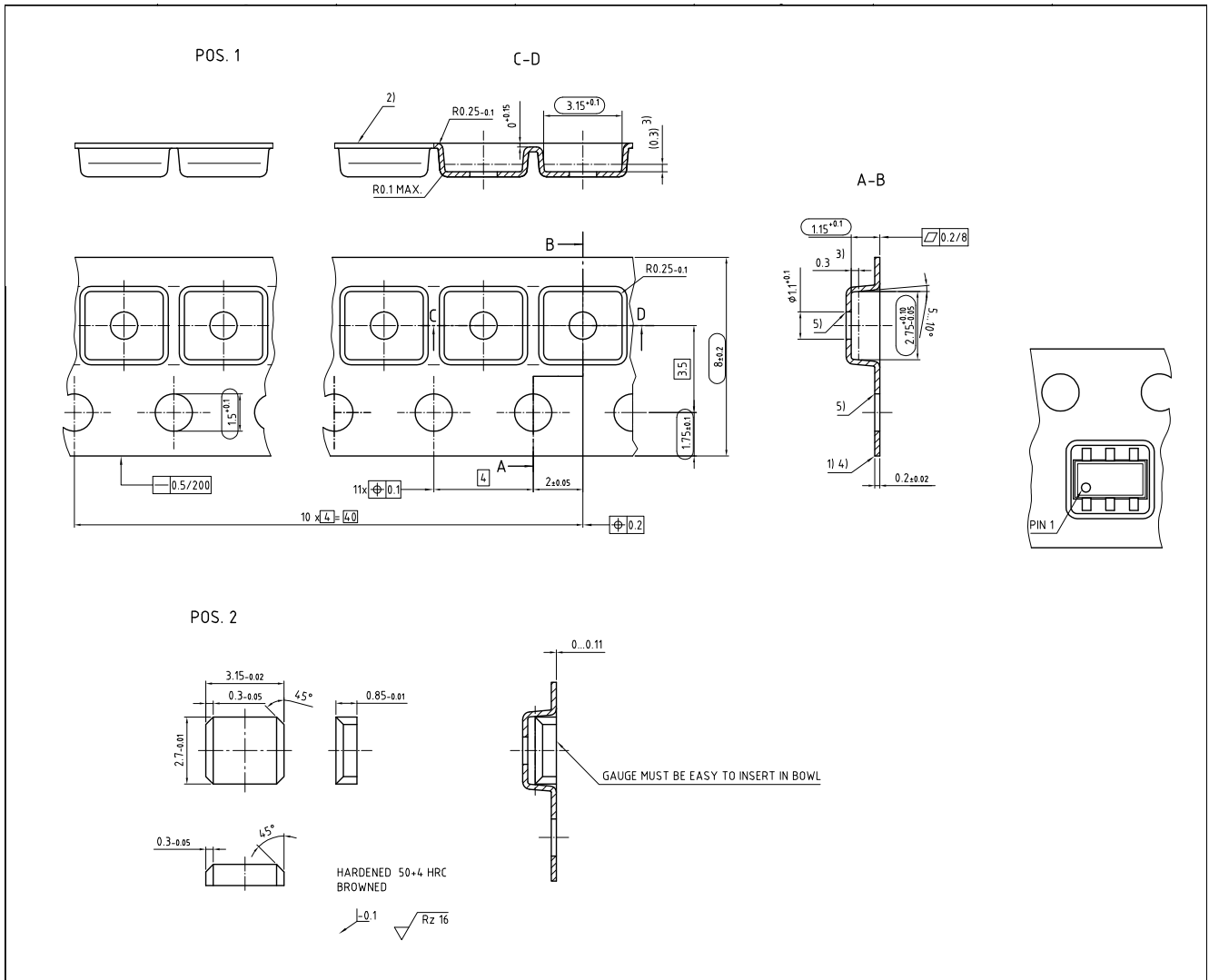

Figure 13 Packing (all dimensions in mm)

Further Information about the package can be found here:

http://www.infineon.com/cms/packages/SMD_-_Surface_Mounted_Devices/TSOP/TSOP6.html

Revision History

8 Revision History

Revision	Date	Changes
Rev. 1.0	2016-01-29	Initial version

Trademarks of Infineon Technologies AG

AURIX™, C166™, CanPAK™, CIPOS™, CIPURSE™, CoolMOS™, CoolSET™, CORECONTROL™, CROSSAVE™, DAVE™, DI-POL™, EasyPIM™, EconoBRIDGE™, EconoDUAL™, EconoPIM™, EconoPACK™, EiceDRIVER™, eupec™, FCOS™, HITFET™, HybridPACK™, I²RF™, ISOFACE™, IsoPACK™, MIPAQ™, ModSTACK™, my-d™, NovalithIC™, OptiMOS™, ORIGA™, POWERCODE™, PRIMARION™, PrimePACK™, PrimeSTACK™, PRO-SIL™, PROFET™, RASIC™, ReverSave™, SatRIC™, SIEGET™, SINDRION™, SIPMOS™, SmartLEWIS™, SPOC™, SOLID FLASH™, TEMPFET™, thinQ!™, TRENCHSTOP™, TriCore™.

Other Trademarks

Advance Design System™ (ADS) of Agilent Technologies, AMBA™, ARM™, MULTI-ICE™, KEIL™, PRIMECELL™, REALVIEW™, THUMB™, μVision™ of ARM Limited, UK. AUTOSAR™ is licensed by AUTOSAR development partnership. Bluetooth™ of Bluetooth SIG Inc. CAT-iq™ of DECT Forum. COLOSSUS™, FirstGPS™ of Trimble Navigation Ltd. EMV™ of EMVCo, LLC (Visa Holdings Inc.). EPCOS™ of Epcos AG. FLEXGO™ of Microsoft Corporation. FlexRay™ is licensed by FlexRay Consortium. HYPERTERMINAL™ of Hilgraeve Incorporated. IEC™ of Commission Electrotechnique Internationale. IrDA™ of Infrared Data Association Corporation. ISO™ of INTERNATIONAL ORGANIZATION FOR STANDARDIZATION. MATLAB™ of MathWorks, Inc. MAXIM™ of Maxim Integrated Products, Inc. MICROTEC™, NUCLEUS™ of Mentor Graphics Corporation. MIPI™ of MIPI Alliance, Inc. MIPS™ of MIPS Technologies, Inc., USA. muRata™ of MURATA MANUFACTURING CO., MICROWAVE OFFICE™ (MWO) of Applied Wave Research Inc., OmniVision™ of OmniVision Technologies, Inc. Openwave™ Openwave Systems Inc. RED HAT™ Red Hat, Inc. RFMD™ RF Micro Devices, Inc. SIRIUS™ of Sirius Satellite Radio Inc. SOLARIS™ of Sun Microsystems, Inc. SPANSION™ of Spansion LLC Ltd. Symbian™ of Symbian Software Limited. TAIYO YUDEN™ of Taiyo Yuden Co. TEAKLITE™ of CEVA, Inc. TEKTRONIX™ of Tektronix Inc. TOKO™ of TOKO KABUSHIKI KAISHA TA. UNIX™ of X/Open Company Limited. VERILOG™, PALLADIUM™ of Cadence Design Systems, Inc. VLYNQ™ of Texas Instruments Incorporated. VXWORKS™, WIND RIVER™ of WIND RIVER SYSTEMS, INC. ZETEX™ of Diodes Zetex Limited.

Last Trademarks Update 2011-11-11

www.infineon.com

Edition 2016-01-29

Published by

Infineon Technologies AG

81726 Munich, Germany

© 2014 Infineon Technologies AG.

All Rights Reserved.

Do you have a question about any aspect of this document?

Email: erratum@infineon.com

Document reference

Legal Disclaimer

The information given in this document shall in no event be regarded as a guarantee of conditions or characteristics. With respect to any examples or hints given herein, any typical values stated herein and/or any information regarding the application of the device, Infineon Technologies hereby disclaims any and all warranties and liabilities of any kind, including without limitation, warranties of non-infringement of intellectual property rights of any third party.

Information

For further information on technology, delivery terms and conditions and prices, please contact the nearest Infineon Technologies Office (www.infineon.com).

Warnings

Due to technical requirements, components may contain dangerous substances. For information on the types in question, please contact the nearest Infineon Technologies Office. Infineon Technologies components may be used in life-support devices or systems only with the express written approval of Infineon Technologies, if a failure of such components can reasonably be expected to cause the failure of that life-support device or system or to affect the safety or effectiveness of that device or system. Life support devices or systems are intended to be implanted in the human body or to support and/or maintain and sustain and/or protect human life. If they fail, it is reasonable to assume that the health of the user or other persons may be endangered.



Компания «ЭлектроПласт» предлагает заключение долгосрочных отношений при поставках импортных электронных компонентов на взаимовыгодных условиях!

Наши преимущества:

- Оперативные поставки широкого спектра электронных компонентов отечественного и импортного производства напрямую от производителей и с крупнейших мировых складов;
- Поставка более 17-ти миллионов наименований электронных компонентов;
- Поставка сложных, дефицитных, либо снятых с производства позиций;
- Оперативные сроки поставки под заказ (от 5 рабочих дней);
- Экспресс доставка в любую точку России;
- Техническая поддержка проекта, помощь в подборе аналогов, поставка прототипов;
- Система менеджмента качества сертифицирована по Международному стандарту ISO 9001;
- Лицензия ФСБ на осуществление работ с использованием сведений, составляющих государственную тайну;
- Поставка специализированных компонентов (Xilinx, Altera, Analog Devices, Intersil, Interpoint, Microsemi, Aeroflex, Peregrine, Syfer, Eurofarad, Texas Instrument, Miteq, Cobham, E2V, MA-COM, Hittite, Mini-Circuits, General Dynamics и др.);

Помимо этого, одним из направлений компании «ЭлектроПласт» является направление «Источники питания». Мы предлагаем Вам помощь Конструкторского отдела:

- Подбор оптимального решения, техническое обоснование при выборе компонента;
- Подбор аналогов;
- Консультации по применению компонента;
- Поставка образцов и прототипов;
- Техническая поддержка проекта;
- Защита от снятия компонента с производства.



Как с нами связаться

Телефон: 8 (812) 309 58 32 (многоканальный)

Факс: 8 (812) 320-02-42

Электронная почта: org@eplast1.ru

Адрес: 198099, г. Санкт-Петербург, ул. Калинина, дом 2, корпус 4, литера А.