

High Frequency Ceramic Solutions

862 - 928MHz, 2.4 - 2.5GHz Integrated Impedance-matched Balun Filter P/N: 0900PC15A0036 for Texas Instruments CC1352R and CC1352P

Detail Specification: 11/16/2018

Page 1 of 6

Do you need a small sub-GHz or 2.4GHz antenna? Go to: <https://www.johansontechnology.com/antennas>

General Specifications

Part Number	0900PC15A0036	
Frequency (MHz)	862 - 928	2400 - 2500
Insertion Loss (dB)	1.8 typ (2.0 max.)	1.3 typ (1.6 max.)
Return Loss (dB)	14 typ. (10 min.)	14 typ. (10 min.)
Phase Balance (deg)	180±15	180±15
Amplitude Difference (dB)	0.8 typ. (1.5 max.)	1.0 typ. (2.0 max.)
Attenuation (dB @MHz)	17 min. @1736 - 1856 40 min. @2604 - 2784	20 min. @4800 - 5000 40 min. @7200 - 7500
Unbalanced Impedance (Ω)	50	
Balanced Impedance (Ω)	Impedance matched to Texas Instruments CC1352R and CC1352P	
Power Capacity (W)	3 max. CW	
Operating Temperature	-40°C to +85°C	
Quantity/Reel	4,000	

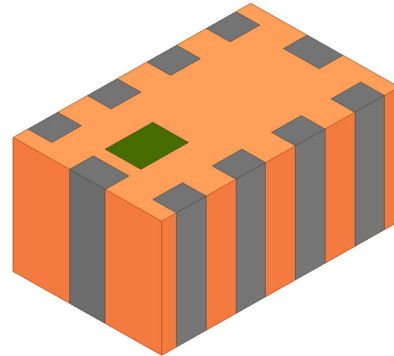

Recommended Storage Conditions for unused T&R product

+5 to +35°C
Humidity 45 - 75%RH
18 months max.*

*18 months max. in vacuum sealed bag, 1 week once opened. Please see: <https://www.johansontechnology.com/silverleads-profile>

Part Number Explanation

P/N Suffix	Packing Style	Bulk	Suffix = S	eg. 0900PC15A0036S
		T & R	Suffix = E	eg. 0900PC15A0036E
		100% Tin	Suffix = None	eg. 0900PC15A0036(E or S)

For more Texas Instruments matched balun-filters, go to: <https://www.johansontechnology.com/ti>

Mechanical Dimensions

	In	mm
L	0.079 ± 0.008	2.00 ± 0.2
W	0.049 ± 0.008	1.25 ± 0.2
T	0.039 max.	1.00 max.
a	0.010 ± 0.004	0.25 ± 0.1
b	0.012 ± 0.006	0.30 ± 0.15
c	0.008+0.004/-0.006	0.20 +0.1/-0.15
d	0.020 ± 0.004	0.50 ± 0.1

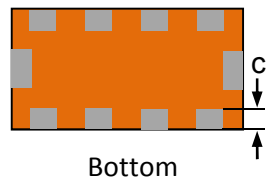
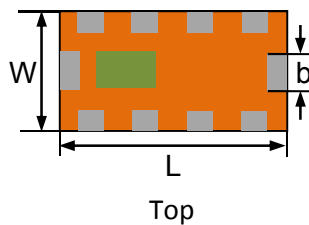
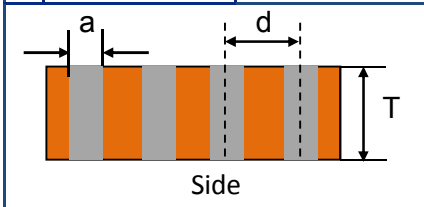

Terminal Configuration

No.	Function	No.	Function
1	ANT (2.4GHz)	6	RF_N (Sub-GHz)
2	GND	7	RF_P (Sub-GHz)
3	GND	8	RF_N (2.4GHz)
4	ANT (Sub-GHz)	9	RF_P (2.4GHz)
5	RX_TX	10	GND

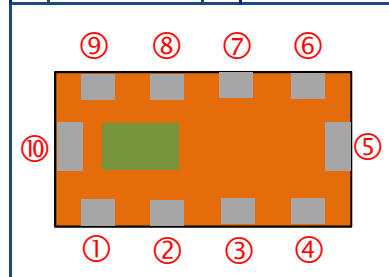

Johanson Technology, Inc. reserves the right to make design changes without notice.
All sales are subject to Johanson Technology, Inc. terms and conditions.



<https://www.johansontechnology.com>

4001 Calle Tecate • Camarillo, CA 93012 • TEL 805.389.1166 FAX 805.389.1821

Ver. 1.0

2018 Johanson Technology, Inc. All Rights Reserved

High Frequency Ceramic Solutions

862 - 928MHz, 2.4 - 2.5GHz Integrated Impedance-matched Balun Filter
for Texas Instruments CC1352R and CC1352P

P/N: 0900PC15A0036

Detail Specification: 11/16/2018

Page 2 of 6

Pad-Soldermask Guidelines

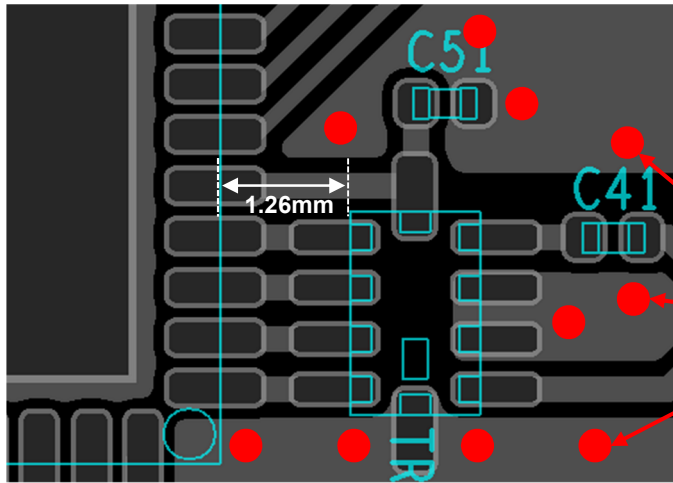

Component Layer

Solder Pads

GND Via

GND vias are crucial for filter harmonic attenuation

For reference design package and PCB CAD files
please contact us at: <https://www.johansontechnology.com/ask-a-question>

PCB Reference Design Schematic

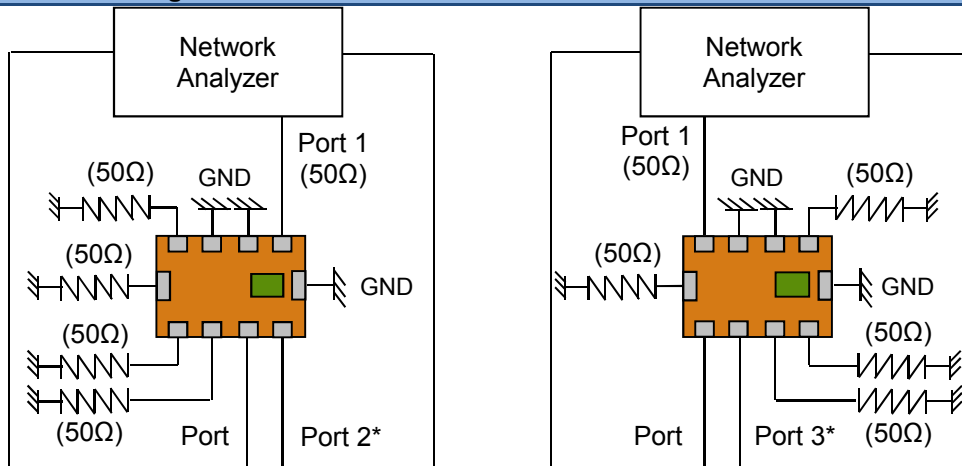

Port 1: Unbalanced Port, **Ports 2 and 3:** Balanced Port

*Impedance for ports 2 and 3 = Conjugate to Balanced Impedance/2

Johanson Technology, Inc. reserves the right to make design changes without notice.

All sales are subject to Johanson Technology, Inc. terms and conditions.



<https://www.johansontechnology.com>

4001 Calle Tecate • Camarillo, CA 93012 • TEL 805.389.1166 FAX 805.389.1821

Ver. 1.0

2018 Johanson Technology, Inc. All Rights Reserved

High Frequency Ceramic Solutions

862 - 928MHz, 2.4 - 2.5GHz Integrated Impedance-matched Balun Filter
for Texas Instruments CC1352R and CC1352P

P/N: 0900PC15A0036

Detail Specification: 11/16/2018

Page 3 of 6

Discrete Components Integrated into IPC

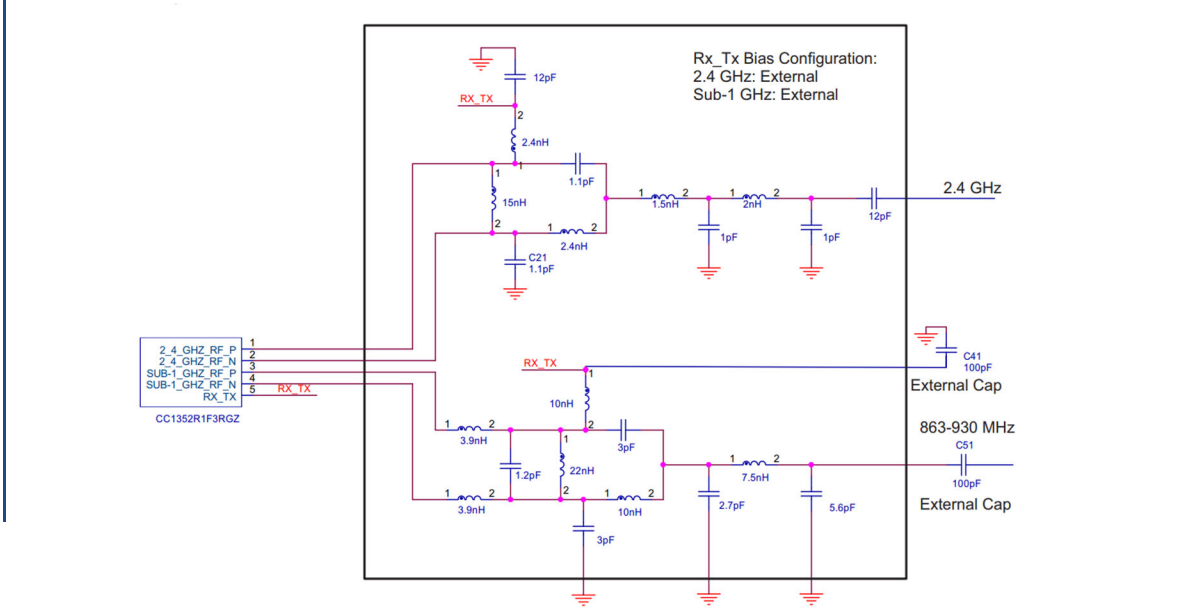

PCB Reference Design Schematic

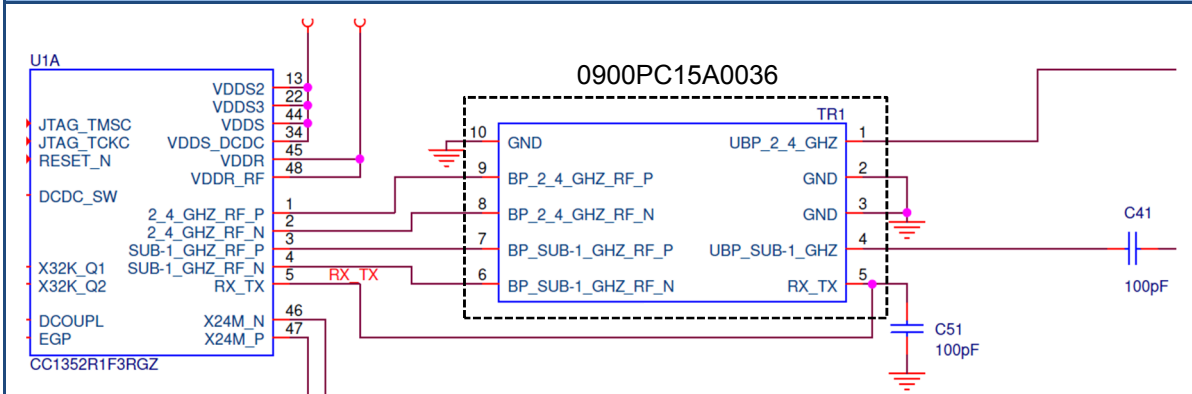

TI CC1352 RX_TX should be configured as external biasing for both Sub-GHz and 2.4GHz Rx operation

Johanson Technology, Inc. reserves the right to make design changes without notice.
 All sales are subject to Johanson Technology, Inc. terms and conditions.



<https://www.johansontechnology.com>

4001 Calle Tecate • Camarillo, CA 93012 • TEL 805.389.1166 FAX 805.389.1821

Ver. 1.0

2018 Johanson Technology, Inc. All Rights Reserved

High Frequency Ceramic Solutions

862 - 928MHz, 2.4 - 2.5GHz Integrated Impedance-matched Balun Filter
for Texas Instruments CC1352R and CC1352P

P/N: 0900PC15A0036

Detail Specification: 11/16/2018

Page 4 of 6

Sub-GHz Electrical Characteristics at T=25°C

Insertion Loss, Attenuation

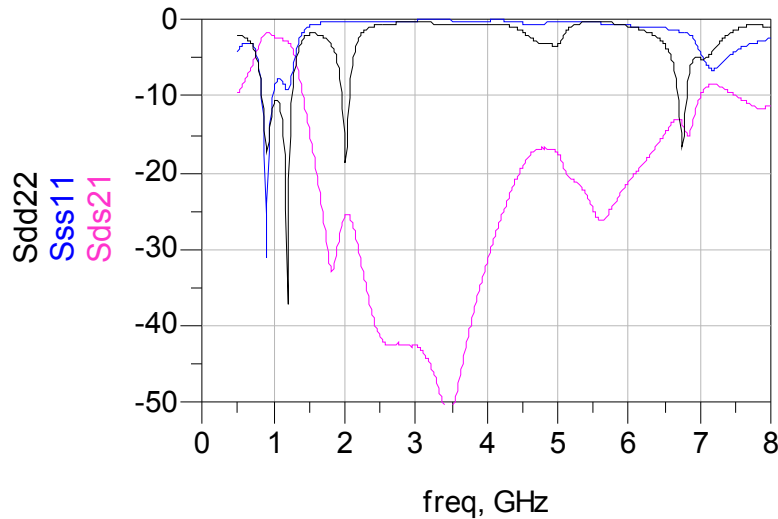

Phase Balance, Amplitude Difference

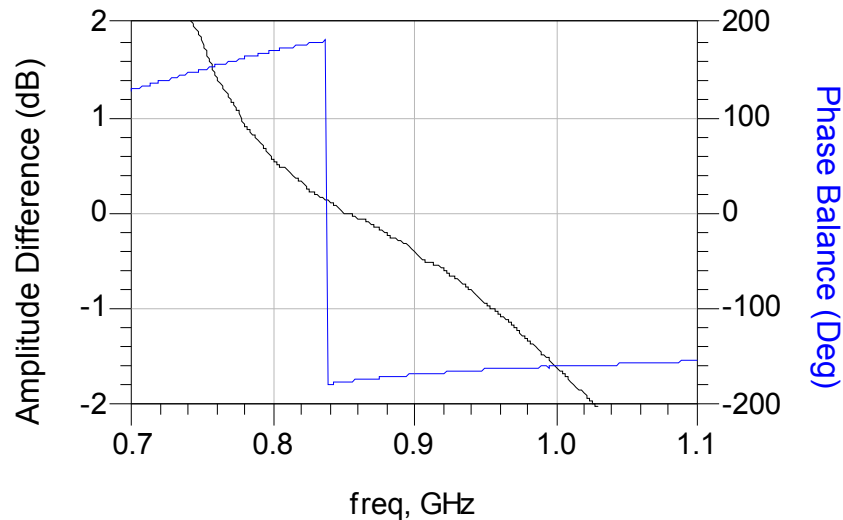

Johanson Technology, Inc. reserves the right to make design changes without notice.
All sales are subject to Johanson Technology, Inc. terms and conditions.



<https://www.johansontechnology.com>

4001 Calle Tecate • Camarillo, CA 93012 • TEL 805.389.1166 FAX 805.389.1821

Ver. 1.0

2018 Johanson Technology, Inc. All Rights Reserved

High Frequency Ceramic Solutions

862 - 928MHz, 2.4 - 2.5GHz Integrated Impedance-matched Balun Filter
for Texas Instruments CC1352R and CC1352P

P/N: 0900PC15A0036

Detail Specification: 11/16/2018

Page 5 of 6

2.4GHz Electrical Characteristics at T=25°C

Insertion Loss, Attenuation

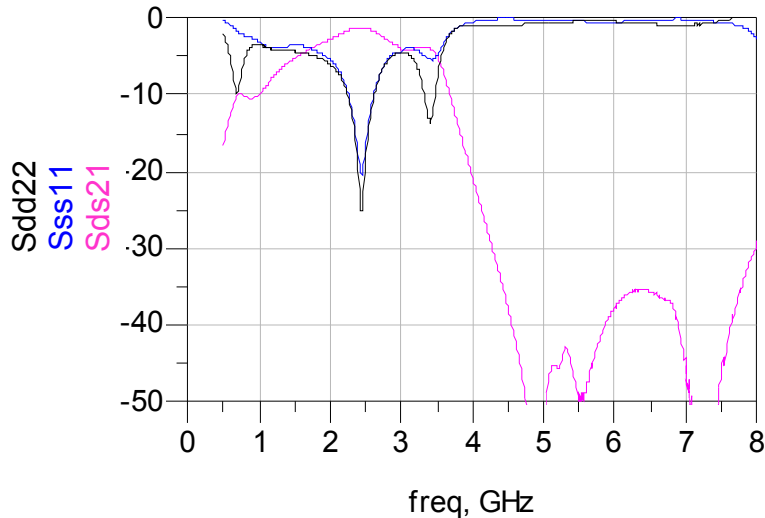

Phase Balance, Amplitude Difference

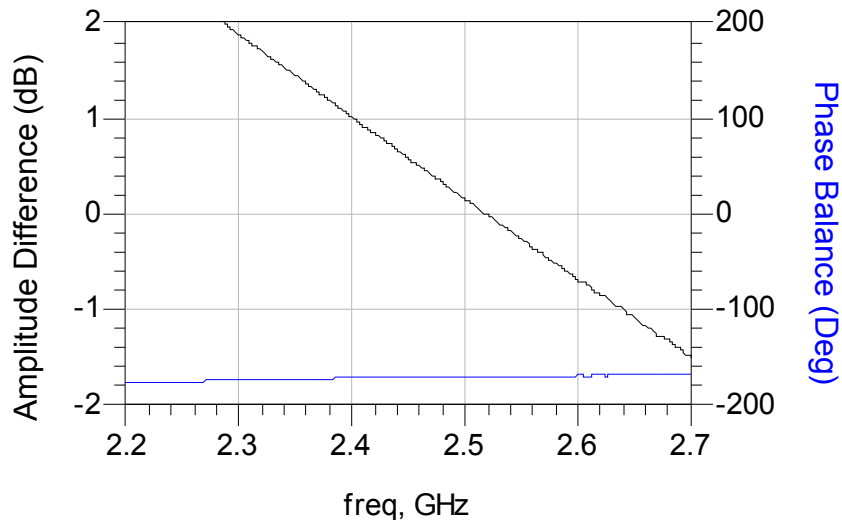

Johanson Technology, Inc. reserves the right to make design changes without notice.
All sales are subject to Johanson Technology, Inc. terms and conditions.



<https://www.johansontechnology.com>

4001 Calle Tecate • Camarillo, CA 93012 • TEL 805.389.1166 FAX 805.389.1821

Ver. 1.0

2018 Johanson Technology, Inc. All Rights Reserved

High Frequency Ceramic Solutions

862 - 928MHz, 2.4 - 2.5GHz Integrated Impedance-matched Balun Filter for Texas Instruments CC1352R and CC1352P P/N: 0900PC15A0036

Detail Specification: 11/16/2018

Page 6 of 6

Application Notes, Layout Files, and more

<https://www.johansontechnology.com/ti>

Small SMD 900MHz (or 2.4G, 5G) antennas at:

<https://www.johansontechnology.com/antennas>

RoHS Compliance

<https://www.johansontechnology.com/rohs-compliance>

Soldering Information

<https://www.johansontechnology.com/ipcsoldering-profile>

Antenna layout and tuning techniques

<https://www.johansontechnology.com/tuning>

Antenna layout review, tuning, and characterization services

<https://www.johansontechnology.com/ipc-antenna-services>

MSL Info

<https://www.johansontechnology.com/msl-rating>

Recommended Storage Condition and Max Shelf Life

<https://www.johansontechnology.com/recommended-storage-conditions>

Packaging information

<https://www.johansontechnology.com/tape-reel-packaging>

Silverleads Information

<https://www.johansontechnology.com/silverleads-profile>

Texas Instruments Application Note

<https://www.ti.com/lit/an/swra629/swra629.pdf>

Would you like us to review your layout for free? Need an embedded antenna recommendation for your application?
Contact us at:

<https://www.johansontechnology.com/ask-a-question>

Johanson Technology, Inc. reserves the right to make design changes without notice.

All sales are subject to Johanson Technology, Inc. terms and conditions.



<https://www.johansontechnology.com>
4001 Calle Tecate • Camarillo, CA 93012 • TEL 805.389.1166 FAX 805.389.1821
Ver. 1.0 2018 Johanson Technology, Inc. All Rights Reserved



Компания «ЭлектроПласт» предлагает заключение долгосрочных отношений при поставках импортных электронных компонентов на взаимовыгодных условиях!

Наши преимущества:

- Оперативные поставки широкого спектра электронных компонентов отечественного и импортного производства напрямую от производителей и с крупнейших мировых складов;
- Поставка более 17-ти миллионов наименований электронных компонентов;
- Поставка сложных, дефицитных, либо снятых с производства позиций;
- Оперативные сроки поставки под заказ (от 5 рабочих дней);
- Экспресс доставка в любую точку России;
- Техническая поддержка проекта, помощь в подборе аналогов, поставка прототипов;
- Система менеджмента качества сертифицирована по Международному стандарту ISO 9001;
- Лицензия ФСБ на осуществление работ с использованием сведений, составляющих государственную тайну;
- Поставка специализированных компонентов (Xilinx, Altera, Analog Devices, Intersil, Interpoint, Microsemi, Aeroflex, Peregrine, Syfer, Eurofarad, Texas Instrument, Miteq, Cobham, E2V, MA-COM, Hittite, Mini-Circuits, General Dynamics и др.);

Помимо этого, одним из направлений компании «ЭлектроПласт» является направление «Источники питания». Мы предлагаем Вам помощь Конструкторского отдела:

- Подбор оптимального решения, техническое обоснование при выборе компонента;
- Подбор аналогов;
- Консультации по применению компонента;
- Поставка образцов и прототипов;
- Техническая поддержка проекта;
- Защита от снятия компонента с производства.



Как с нами связаться

Телефон: 8 (812) 309 58 32 (многоканальный)

Факс: 8 (812) 320-02-42

Электронная почта: org@eplast1.ru

Адрес: 198099, г. Санкт-Петербург, ул. Калинина, дом 2, корпус 4, литера А.