



General Description

The SLG3NT3353 uses a 25 MHz Reference Crystal to provide four 25 MHz clock outputs.

Features

- Improved performance over temperature
- Supports Industrial temperature range
- Smaller package and layout foot print
- 8-pin TDFN: 2 x 2 x 0.75 mm, 0.5 mm pitch
- Pb-Free / Halogen-Free / RoHS compliant

Output Summary

- 4x 25 MHz clock outputs (2.0 mA)

Pin Configuration

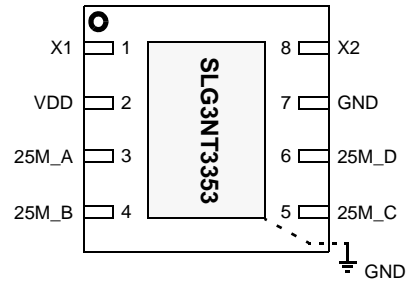

8-pin TDFN
(Top View)

Block Diagram

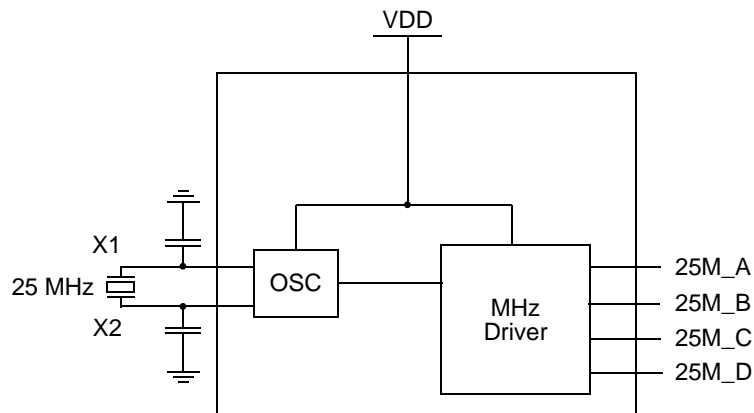



Pin Description

Pin #	Pin Name	Type ¹	Pin Description ²
1	X1	I	Crystal Interface: 25 MHz, OSC input
2	VDD	PWR	Power Supply: 3.3 V for normal operation
3	25M_A	O, SE	Clock Output: 25 MHz output
4	25M_B	O, SE	Clock Output: 25 MHz output
5	25M_C	O, SE	Clock Output: 25 MHz output
6	25M_D	O, SE	Clock Output: 25 MHz output
7	GND	GND	Ground
8	X2	O, SE	Crystal Interface: 25 MHz, OSC output
Exposed Bottom Pad	GND	GND	Ground

Notes:

1. Type Definitions

- PWR: power
- GND: ground
- I: input
- O: output
- SE: single ended signal

2. It is recommended that all Power Supply pins have a decoupling capacitor attached (0.1 μ F minimum).



Absolute Maximum Ratings

Parameter	Description	Min.	Max.	Unit
V _{DD}	Voltage on VDD pin relative to GND	-0.3	4.2	V
T _S	Storage Temperature	-65	150	°C
ESD _{HBM}	ESD Protection (Human Body Model)	2000	--	V
MSL	Moisture Sensitivity Level	1		

Note: Stresses greater than those listed under "Absolute Maximum Ratings" may cause permanent damage to the device. This is a stress rating only and functional operation of the device at these or any other conditions above those indicated in the operational sections of this specification is not implied. Exposure to absolute maximum rating conditions for extended periods may affect reliability.

Recommended Operating Temperature

Parameter	Description	Min.	Max.	Unit
T _O	Operating Temperature	-40	85	°C

Recommended 25 MHz Reference Crystal Specifications

Description	Conditions	Min	Typ	Max	Unit
Initial Frequency		--	25	--	MHz
Frequency Tolerance	@ 25 °C	--	--	±10	ppm
Frequency Stability over Operating Temperature Range	@ -40 °C to 85 °C	--	--	±10	ppm
Frequency Aging	per year	--	--	±1 ¹	ppm
Drive Level		--	--	100	μW
Crystal Load Capacitance	Parallel Resonance	8			pF
Fundamental Mode AT Cut Crystal		--	--	--	

Notes:

1. Vendor Specific: Frequency aging may be different per crystal used. Check with crystal vendor for specific value. SLG3NT3353 outputs will track the crystal frequency aging as stated in other sections of this datasheet.



25 MHz Clock Output Characteristics

$T_A = 25\text{ }^\circ\text{C}$, $V_{DD} = 3.3\text{ V}$ (unless otherwise stated)

Symbol	Description	Conditions	Min	Typ	Max	Unit
F_{INI}	Initial Frequency		--	25	--	MHz
F_{ERRI}	Frequency Error at Room Temperature	@ 25 °C	Reference Crystal ¹			ppm
F_{ERRT}	Frequency Error over Operating Temperature Range	@ -40 °C to 85 °C	Reference Crystal ¹			ppm
F_{AGE}	Frequency Aging	per year	Reference Crystal ¹			ppm
DC	Duty Cycle	$0.5 \times V_{DDIO_24M_A}$	45	50	55	%
V_{OH}	Output Voltage HIGH	$I_{OH} = 1\text{ mA}$	2.6	--	--	V
V_{OL}	Output Voltage LOW	$I_{OL} = -1\text{ mA}$	--	--	0.7	V

Notes:

1. This parameter tracks Reference Crystal characteristics.

Power Supply Electrical Specifications (VDD)

$T_A = 25\text{ }^\circ\text{C}$

Symbol	Description	Conditions	Min	Typ	Max	Unit
V_{DD}	Operating Voltage for VDD		3.0	3.3	3.6	V
I_{VDD}^1	V_{DD} current consumption in normal operation	$V_{DD} = 3.3\text{ V}$, No Load	--	2.0	--	mA

Notes:

1. Average current depends on application and output load.



Package Top Marking System Definition

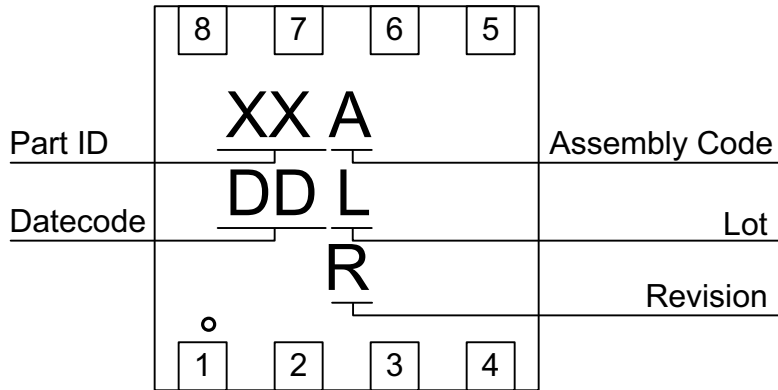

- XX – Part ID Field: identifies the specific device configuration
- A – Assembly Code Field: Assembly Location of the device.
- DD – Date Code Field: Coded date of manufacture
- L – Lot Code: Designates Lot #
- R – Revision Code: Device Revision



Package Drawing and Dimensions

**8 Lead TDFN Package
JEDEC MO-229, Variation WCCD**

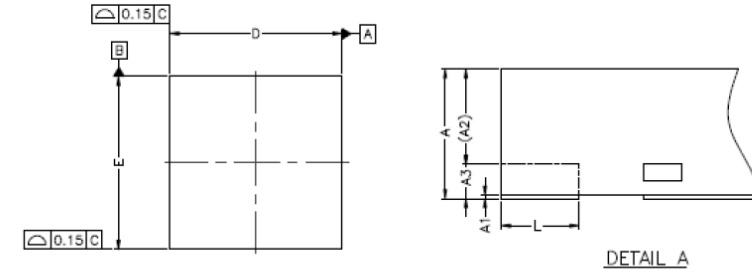

DETAIL A

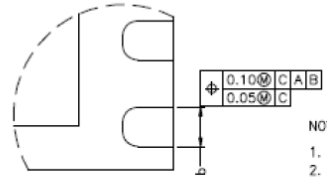
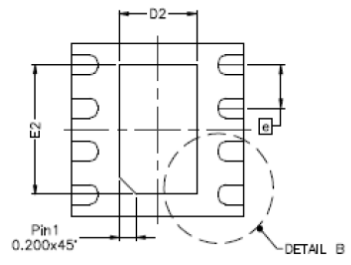
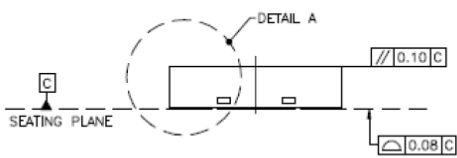

DETAIL B

SYMBOL	DIMENSION (MM)			DIMENSION (MIL)		
	MIN.	NOM.	MAX.	MIN.	NOM.	MAX.
A	0.70	0.75	0.80	28	30	31
A1	0.00	0.02	0.05	0	1	2
A2	0	0.55	0.80	0	22	31
A3	—	0.20	—	—	8	—
b	0.18	0.25	0.30	7	10	12
D	1.90	2.00	2.10	74	79	83
D1	—			—		
D2	0.75	0.90	1.05	30	35	41
E	1.90	2.00	2.10	75	79	83
E1	—			—		
E2	1.50	1.65	1.70	53	59	65
e	0.50 BSC			20 BSC		
L	0.25	0.30	0.35	10	12	14

- NOTE :
- REFER TO JEDEC STD: MO-229.
 - DIMENSION "b" APPLIES TO METALLIZED TERMINAL AND IS MEASURED BETWEEN 0.15MM AND 0.30MM FROM THE TERMINAL TIP. IF THE TERMINAL HAS OPTIONAL RADIUS ON THE OTHER END OF THE TERMINAL, THE DIMENSION B SHOULD NOT BE MEASURED IN THAT RADIUS AREA.



Tape and Reel Specifications

Package Type	# of Pins	Nominal Package Size [mm]	Max Units		Reel & Hub Size [mm]	Leader (min)		Trailer (min)		Tape Width [mm]	Part Pitch [mm]
			per Reel	per Box		Pockets	Length [mm]	Pockets	Length [mm]		
TDFN 8L Green	8	2 x 2 x 0.75	3,000	3,000	178 / 60	42	400	42	400	8	4

Carrier Tape Drawing and Dimensions

Package Type	Pocket BTM Length	Pocket BTM Width	Pocket Depth	Index Hole Pitch	Pocket Pitch	Index Hole Diameter	Index Hole to Tape Edge	Index Hole to Pocket Center	Tape Width
	A0	B0	K0	P0	P1	D0	E	F	W
TDFN 8L Green	2.3	2.3	1.05	4	4	1.55	1.75	3.5	8

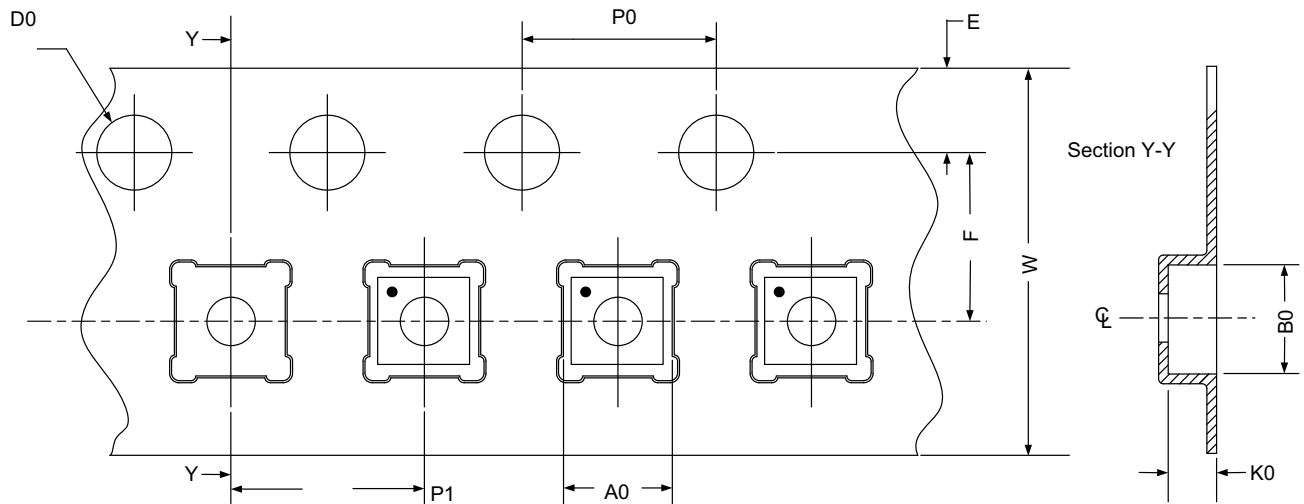

Refer to EIA-481 specification

Recommended Reflow Soldering Profile

Please see IPC/JEDEC J-STD-020: latest revision for reflow profile based on package volume of 3.00 mm³ (nominal). More information can be found at www.jedec.org.



Silego Website & Support

Silego Technology Website

Silego Technology provides online support via our website at <http://www.silego.com/>. This website is used as a means to make files and information easily available to customers.

For more information regarding Silego Green products, please visit:

GreenPAK

<http://greenpak.silego.com/>
<http://greenpak2.silego.com/>
<http://greenpak3.silego.com/>

GreenFET

<http://greenfet.silego.com/>
<http://greenfet2.silego.com/>
<http://greenfet3.silego.com/>

GreenCLK

<http://greenclock.silego.com/>
<http://greenclock2.silego.com/>
<http://greenclock3.silego.com/>

Products are also available for purchase directly from Silego at the Silego Online Store at <http://store.silego.com/>.

Silego Technical Support

Datasheets and errata, application notes and example designs, user guides, and hardware support documents and the latest software releases are available at the Silego website or can be requested directly at info@silego.com.

For specific GreenPAK design or applications questions and support please send e-mail requests to GreenPAK@silego.com

Users of Silego products can receive assistance through several channels:

Online Live Support

Silego Technology has live video technical assistance and sales support available at <http://www.silego.com/>. Please ask our live web receptionist to schedule a 1 on 1 training session with one of our application engineers.

Contact Your Local Sales Representative

Customers can contact their local sales representative or field application engineer (FAE) for support. Local sales offices are also available to help customers. More information regarding your local representative is available at the Silego website or send a request to info@silego.com

Contact Silego Directly

Silego can be contacted directly via e-mail at info@silego.com or user submission form, located at the following URL:

<http://support.silego.com/>

Other Information

The latest Silego Technology press releases, listing of seminars and events, listings of world wide Silego Technology offices and representatives are all available at <http://www.silego.com/>

THIS PRODUCT HAS BEEN DESIGNED AND QUALIFIED FOR THE CONSUMER MARKET. APPLICATIONS OR USES AS CRITICAL COMPONENTS IN LIFE SUPPORT DEVICES OR SYSTEMS ARE NOT AUTHORIZED. SILEGO TECHNOLOGY DOES NOT ASSUME ANY LIABILITY ARISING OUT OF SUCH APPLICATIONS OR USES OF ITS PRODUCTS. SILEGO TECHNOLOGY RESERVES THE RIGHT TO IMPROVE PRODUCT DESIGN, FUNCTIONS AND RELIABILITY WITHOUT NOTICE.



Компания «ЭлектроПласт» предлагает заключение долгосрочных отношений при поставках импортных электронных компонентов на взаимовыгодных условиях!

Наши преимущества:

- Оперативные поставки широкого спектра электронных компонентов отечественного и импортного производства напрямую от производителей и с крупнейших мировых складов;
- Поставка более 17-ти миллионов наименований электронных компонентов;
- Поставка сложных, дефицитных, либо снятых с производства позиций;
- Оперативные сроки поставки под заказ (от 5 рабочих дней);
- Экспресс доставка в любую точку России;
- Техническая поддержка проекта, помощь в подборе аналогов, поставка прототипов;
- Система менеджмента качества сертифицирована по Международному стандарту ISO 9001;
- Лицензия ФСБ на осуществление работ с использованием сведений, составляющих государственную тайну;
- Поставка специализированных компонентов (Xilinx, Altera, Analog Devices, Intersil, Interpoint, Microsemi, Aeroflex, Peregrine, Syfer, Eurofarad, Texas Instrument, Miteq, Cobham, E2V, MA-COM, Hittite, Mini-Circuits, General Dynamics и др.);

Помимо этого, одним из направлений компании «ЭлектроПласт» является направление «Источники питания». Мы предлагаем Вам помощь Конструкторского отдела:

- Подбор оптимального решения, техническое обоснование при выборе компонента;
- Подбор аналогов;
- Консультации по применению компонента;
- Поставка образцов и прототипов;
- Техническая поддержка проекта;
- Защита от снятия компонента с производства.



Как с нами связаться

Телефон: 8 (812) 309 58 32 (многоканальный)

Факс: 8 (812) 320-02-42

Электронная почта: org@eplast1.ru

Адрес: 198099, г. Санкт-Петербург, ул. Калинина, дом 2, корпус 4, литера А.