

## 4 x 52 W quad bridge power amplifier with high side driver and low voltage operation

Datasheet - production data

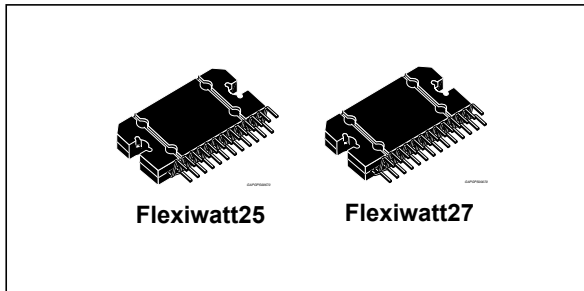

### Features

- High output power capability:
  - 4 x 52 W/4  $\Omega$  max.
  - 4 x 30 W/4  $\Omega$  @ 14.4 V, 1 kHz, 10 %
  - 4 x 85 W/2  $\Omega$  max.
  - 4 x 55 W/2  $\Omega$  @ 14.4V, 1 kHz, 10 %
- MOSFET output power stage
- Capable to operate in low voltage conditions (e.g.: "Start - Stop")
- Excellent GSM noise immunity
- Excellent 2  $\Omega$  driving capability
- Hi-Fi class distortion
- Low output noise
- Standby function and mute function
- Automute at min. supply voltage detection
- Low external component count:
  - Internally fixed gain (26 dB)

- No external compensation
- No bootstrap capacitors
- On board 0.4 A high side driver
- Protections:
  - Output short circuit to GND, to  $V_S$ , across the load
  - Very inductive loads
  - Overtating chip temperature with soft thermal limiter
  - Output DC offset detection
  - Load dump voltage
  - Fortuitous open GND
  - Reversed battery
  - ESD

### Description

The STPA003 is a MOSFET class AB audio power amplifier, designed for high-power car radio. In addition to the outstanding output current capability and distortion performance, the STPA003 is extremely robust against several kinds of fortuitous misconnection.

It is compliant to the most recent OEM specifications for low voltage operation (the so called 'start-stop' battery profile during engine stop).

It includes a DC offset detector and, in Flexiwatt27 package, a high side driver or a clipping detector.

**Table 1. Device summary**

Order code	Package	Packing
STPA003OD-4WX	Flexiwatt25 (with OD)	Tube
STPA003CD-48X	Flexiwatt27 (with CD)	Tube
STPA003HSD-48X	Flexiwatt27 (with HSD)	Tube

# Contents

- 1 Overview ..... 5**
  - 1.1 Block diagram and application circuit ..... 5
- 2 Pin description ..... 8**
- 3 Electrical specifications ..... 10**
  - 3.1 Absolute maximum ratings ..... 10
  - 3.2 Thermal data ..... 10
  - 3.3 Electrical characteristics ..... 11
- 4 Electrical characteristics typical curves ..... 13**
- 5 General information ..... 16**
  - 5.1 Operation ..... 16
  - 5.2 Battery variations ..... 17
    - 5.2.1 Low voltage operation ..... 17
    - 5.2.2 Cranks ..... 17
    - 5.2.3 Advanced battery management (hybrid vehicles) ..... 18
  - 5.3 Protections ..... 19
    - 5.3.1 Short circuits and open circuit operation ..... 19
    - 5.3.2 Over-voltage and load dump protection ..... 19
    - 5.3.3 Thermal protection ..... 19
  - 5.4 Warnings ..... 20
    - 5.4.1 DC offset detection (OD pin) ..... 20
    - 5.4.2 Clipping detection and diagnostics (CD-DIAG pin) ..... 20
  - 5.5 Heat sink definition ..... 21
- 6 Package information ..... 22**
- 7 Revision history ..... 24**

## List of tables

Table 1.	Device summary . . . . .	1
Table 2.	Pin functions . . . . .	9
Table 3.	Absolute maximum ratings . . . . .	10
Table 4.	Thermal data . . . . .	10
Table 5.	Electrical characteristics . . . . .	11
Table 6.	Document revision history . . . . .	24

## List of figures

Figure 1.	Block diagram . . . . .	5
Figure 2.	Standard test and application circuit (Flexiwatt25 with OD) . . . . .	6
Figure 3.	Standard test and application circuit (Flexiwatt25 with HSD) . . . . .	6
Figure 4.	Standard test and application circuit (Flexiwatt27 with CD) . . . . .	7
Figure 5.	Standard test and application circuit (Flexiwatt27 with HSD) . . . . .	7
Figure 6.	Pin connections (top view) . . . . .	8
Figure 7.	Quiescent current vs. supply voltage . . . . .	13
Figure 8.	Output power vs. supply voltage (4 $\Omega$ ) . . . . .	13
Figure 9.	Output power vs. supply voltage (2 $\Omega$ ) . . . . .	13
Figure 10.	Distortion vs. output power (4 $\Omega$ ) . . . . .	13
Figure 11.	Distortion vs. output power (2 $\Omega$ ) . . . . .	13
Figure 12.	Distortion vs. frequency (4 $\Omega$ ) . . . . .	13
Figure 13.	Distortion vs. frequency (2 $\Omega$ ) . . . . .	14
Figure 14.	Distortion vs. output power (4 $\Omega$ , $V_s = 6$ V) . . . . .	14
Figure 15.	Distortion vs. output power (2 $\Omega$ , $V_s = 6$ V) . . . . .	14
Figure 16.	Supply voltage rejection vs. frequency . . . . .	14
Figure 17.	Crosstalk vs. frequency . . . . .	14
Figure 18.	Total power dissipation & efficiency vs. $P_o$ (4 $\Omega$ , Sine) . . . . .	14
Figure 19.	Power dissipation vs. average output power (4 $\Omega$ , audio program simulation) . . . . .	15
Figure 20.	Power dissipation vs. average output power (2 $\Omega$ , audio program simulation) . . . . .	15
Figure 21.	ITU R-ARM frequency response, weighting filter for transient pop. . . . .	15
Figure 22.	SVR charge diagram. . . . .	16
Figure 23.	Battery cranking curve example 1. . . . .	17
Figure 24.	Battery cranking curve example 2. . . . .	18
Figure 25.	Upwards fast battery transitions diagram . . . . .	18
Figure 26.	Load dump protection diagram . . . . .	19
Figure 27.	Thermal protection diagram . . . . .	19
Figure 28.	Audio section waveforms . . . . .	20
Figure 29.	Flexiwatt25 (vertical) mechanical data and package dimensions . . . . .	22
Figure 30.	Flexiwatt27 (Vertical) mechanical data and package dimensions . . . . .	23

# 1 Overview

The STPA003 is a complementary quad audio power amplifier. It is available in two different packages, Flexiwatt25 and Flexiwatt27. It embeds four independent amplifiers working in class AB, a standby, a mute pin and an offset detector output. In the Flexiwatt27 package also a high side driver or a clipping detection pin with diagnostics information is present. In Flexiwatt25, the user can choose to have the offset detector or the high side driver on pin 25. The amplifier is fully operational down to a battery voltage of 6 V, without producing pop noise and continuing to play during battery transitions.

The STPA003 can drive 2 ohm loads and has a very high immunity to disturbs without need of external components or compensation. It is protected against any kind of short or open circuit, over-voltage and over-temperature.

## 1.1 Block diagram and application circuit

Figure 1. Block diagram

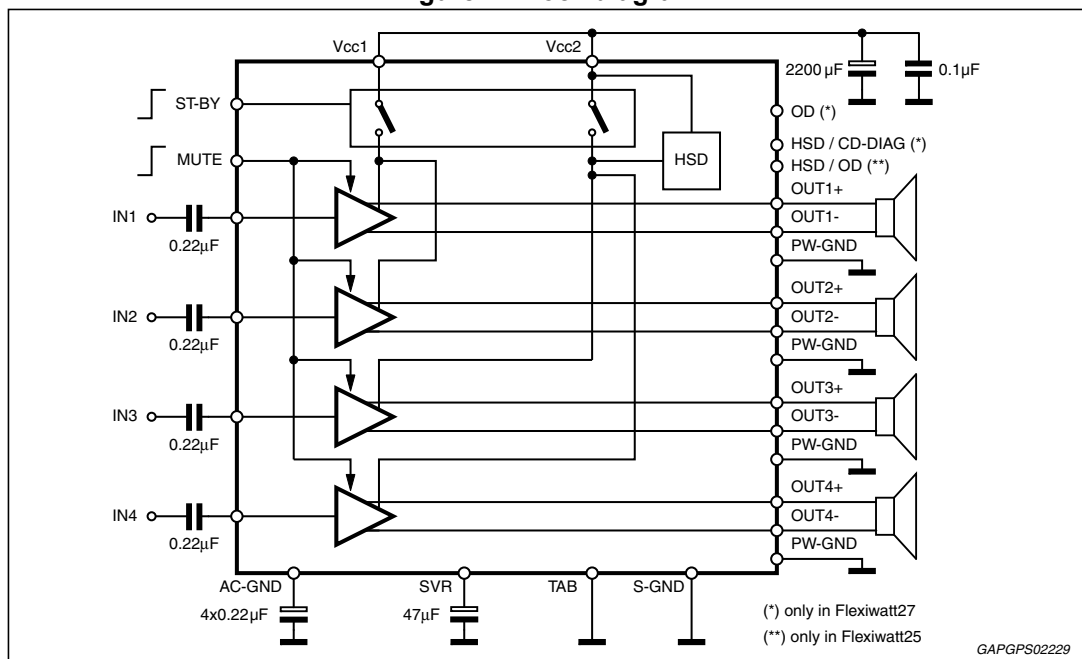

Figure 2. Standard test and application circuit (Flexiwatt25 with OD)

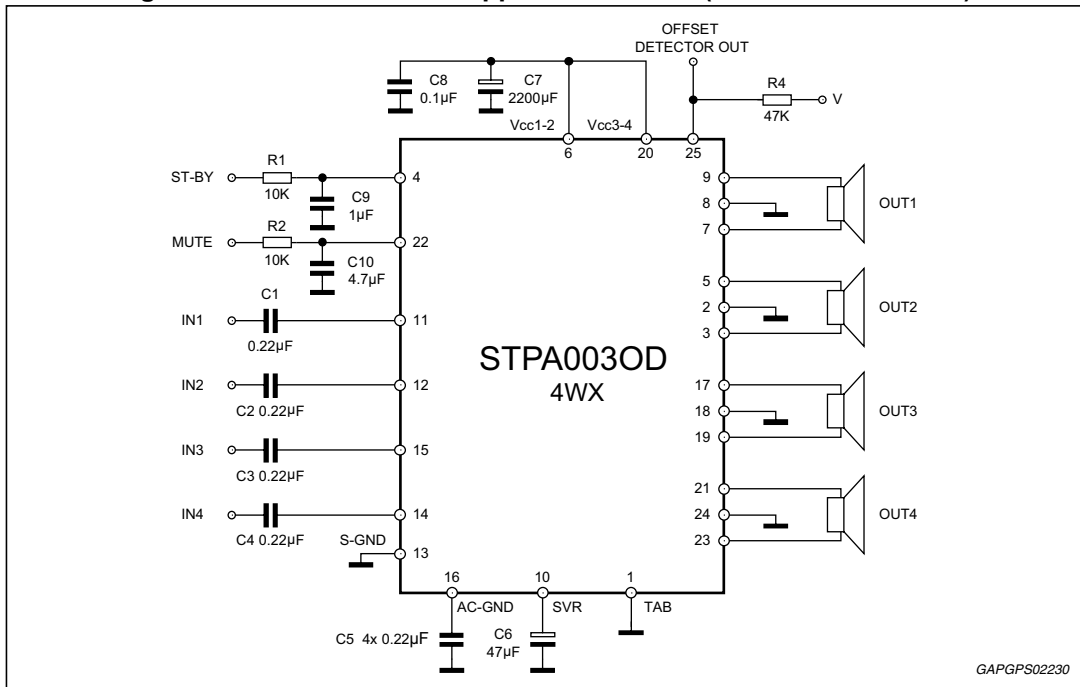

Figure 3. Standard test and application circuit (Flexiwatt27 with CD)

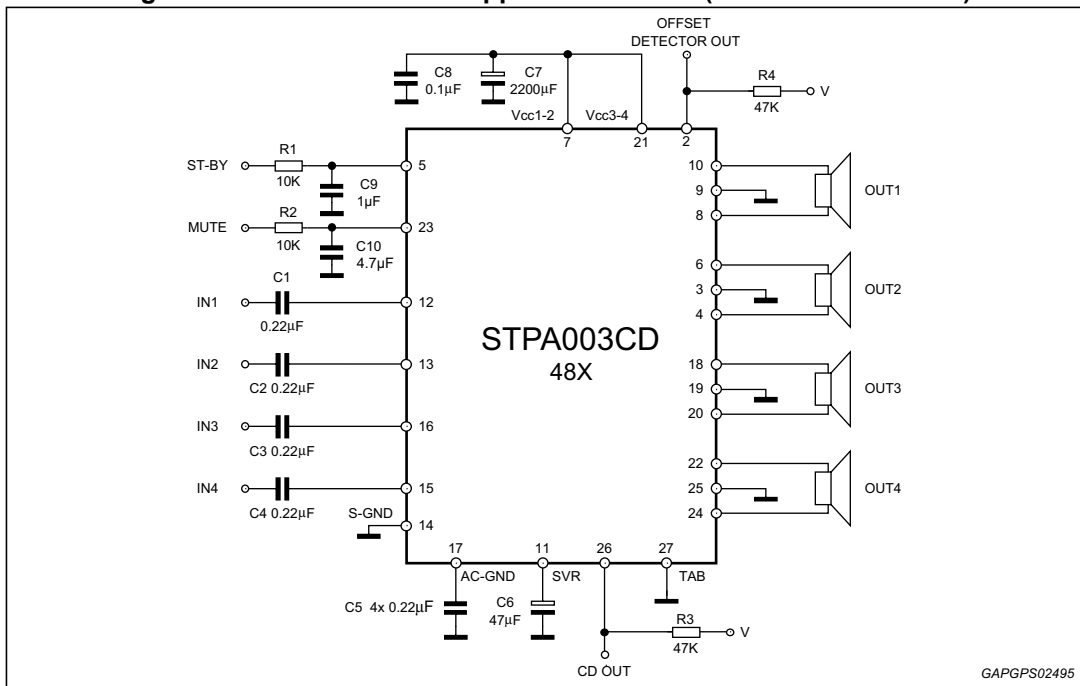
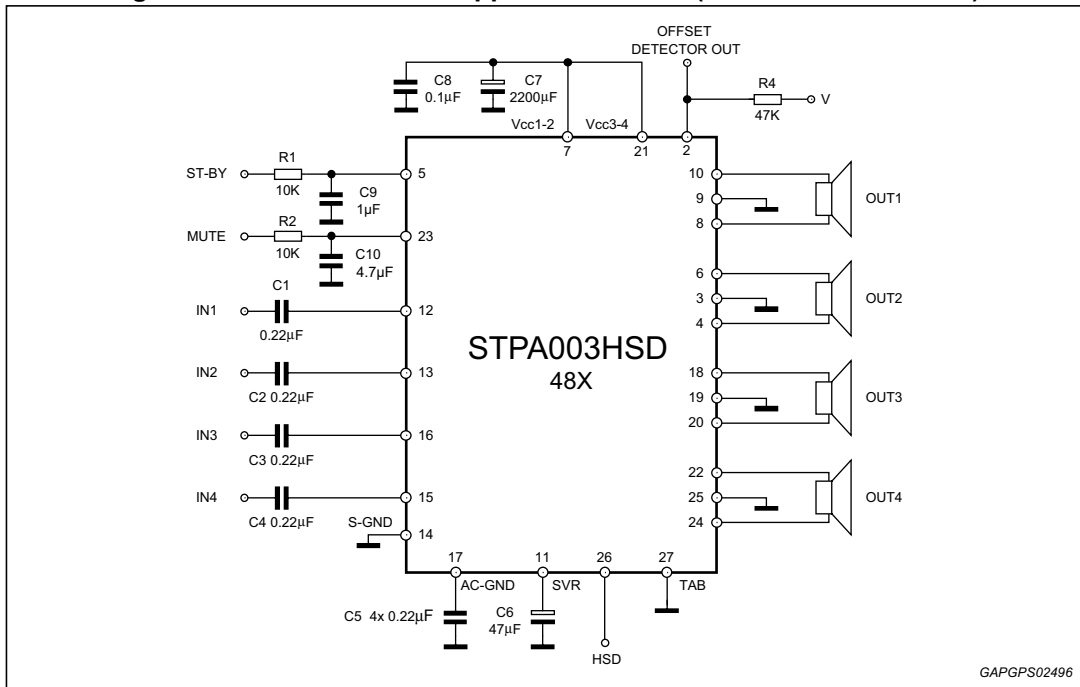

Figure 4. Standard test and application circuit (Flexiwatt27 with HSD)



## 2 Pin description

Figure 5. Pin connections (top view)

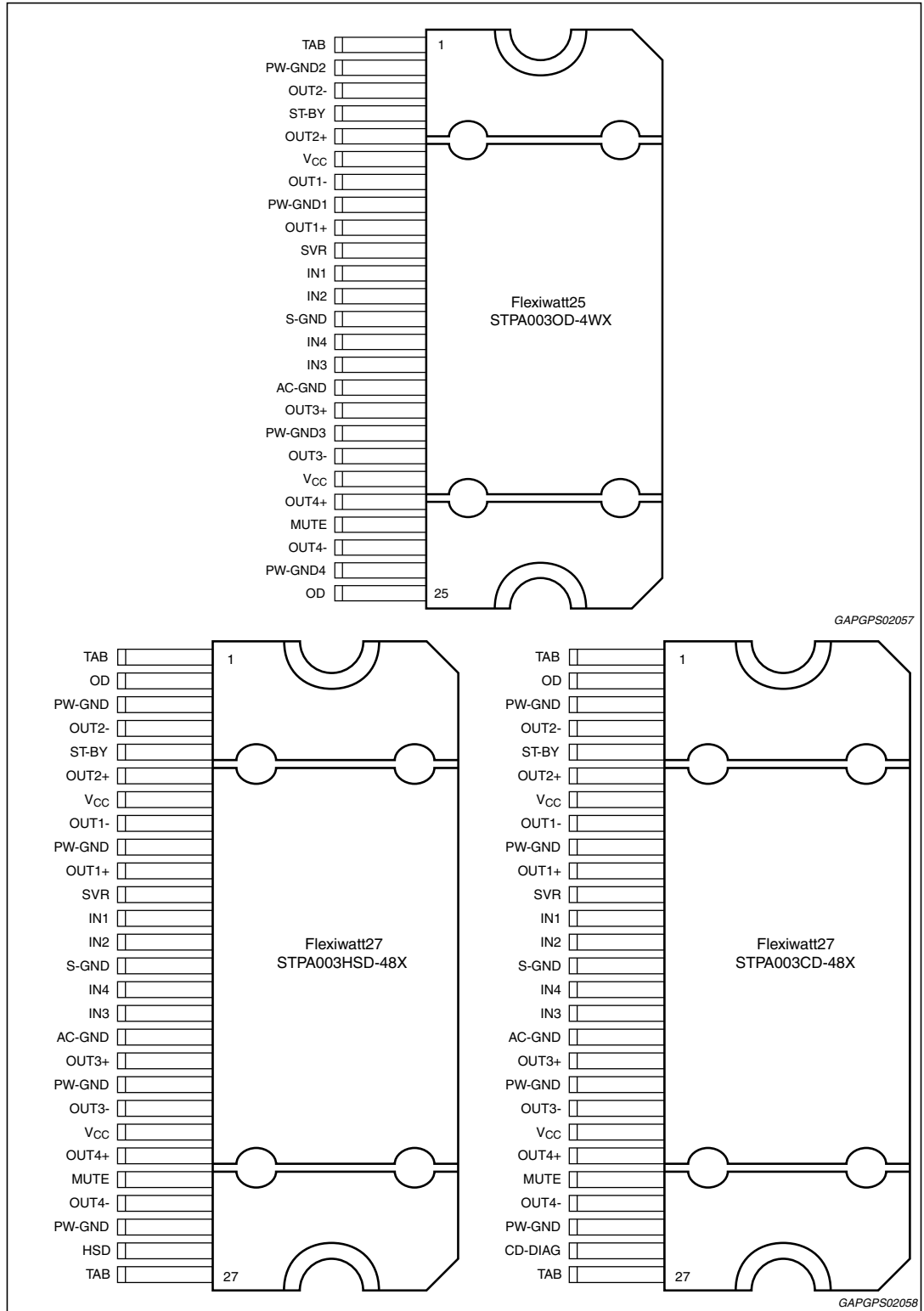



Table 2. Pin functions

Pin # FW27	Pin # FW25	Pin name	Description	Type
1	1	TAB	Device slug connection	-
2	25	OD/HSD	Offset detector output or high side driver output	Output (open collector)
3	2	PW-GND2	Channel 2 power ground	Ground
4	3	OUT2-	Channel 2 negative output	Output
5	4	ST-BY	Standby	-
6	5	OUT2+	Channel 2 positive output	Output
7	6	VCC	Supply voltage	Supply
8	7	OUT1-	Channel 1 negative output	Output
9	8	PW-GND1	Channel 1 power ground	Ground
10	9	OUT1+	Channel 1 positive output	Output
11	10	SVR	Supply voltage rejection pin	Supply
12	11	IN1	Channel 1 input	Input
13	12	IN2	Channel 2 input	Input
14	13	S-GND	Signal ground	Ground
15	14	IN4	Channel 4 input	Input
16	15	IN3	Channel 3 input	Input
17	16	AC-GND	AC ground	Ground
18	17	OUT3+	Channel 3 positive output	Output
19	18	PW-GND3	Channel 3 power ground	Ground
20	19	OUT3-	Channel 3 negative output	Output
21	20	VCC	Supply voltage	Supply
22	21	OUT4+	Channel 4 positive output	Output
23	22	MUTE	Mute pin	Input
24	23	OUT4-	Channel 4 negative output	Output
25	24	PW-GND4	Channel 4 power ground	Ground
26	n.a	HSD / CD-DIAG	High side driver or clipping detector and diagnostics output	Output (open collector)
27	n.a	TAB	Device slug connection	-

### 3 Electrical specifications

#### 3.1 Absolute maximum ratings

Table 3. Absolute maximum ratings

Symbol	Parameter	Value	Unit
$V_S$	Operating supply voltage	18	V
$V_{S(DC)}$	DC supply voltage	28	V
$V_{S(pk)}$	Peak supply voltage (for $t = 50$ ms)	50	V
$I_O$	Output peak current Non repetitive ( $t = 100$ $\mu$ s)	10	A
	Repetitive (duty cycle 10 % at $f = 10$ Hz)	9	A
$P_{tot}$	Power dissipation $T_{case} = 70$ °C	85	W
$T_j$	Junction temperature	150	°C
$T_{stg}$	Storage temperature	-55 to 150	°C
$GND_{max}$	Ground pin voltage	-0.3 to 0.3	V
$V_{in max}$	Input pin max voltage	-0.3 to 8	V
$V_{SB max}$	ST-BY pin max voltage	-0.3 to $V_{S(pk)}$	V
$V_{mute max}$	Mute pin max voltage	-0.3 to 6	V
$T_{op}$	Operating ambient temperature	-40 to 105	°C

#### 3.2 Thermal data

Table 4. Thermal data

Symbol	Parameter	Value	Unit
$R_{th j-case}$	Thermal resistance junction-to-case Max.	1	°C/W

### 3.3 Electrical characteristics

Refer to the test and application diagram,  $V_S = 14.4\text{ V}$ ;  $R_L = 4\ \Omega$ ;  $R_g = 600\ \Omega$ ;  $f = 1\text{ kHz}$ ;  $T_{\text{amb}} = 25\text{ }^\circ\text{C}$ ; unless otherwise specified.

**Table 5. Electrical characteristics**

Symbol	Parameter	Test condition	Min.	Typ.	Max.	Unit
<b>General characteristics</b>						
$V_S$	Supply voltage range	-	6	-	18	V
$I_{q1}$	Quiescent current	$R_L = \infty$	100	200	400	mA
$V_{OS}$	Output offset voltage	Mute mode	-80	-	+80	mV
$dV_{OS}$	Output offset voltage when mute moves from ON to OFF	ITU R-ARM weighted <i>Figure 20</i>	-10	-	+10	mV
	Output offset voltage when stand-by moves from ON to OFF		-10	-	+10	mV
$R_i$	Input impedance	-	50	55	60	k $\Omega$
$I_{SB}$	Standby current consumption	$V_{\text{St-by}} = 0.8\text{ V}$	-	0.2	2	$\mu\text{A}$
		$V_{\text{St-by}} = 0$	-	0.1	1	$\mu\text{A}$
<b>Audio performances</b>						
$P_o$	Output power	$V_S = 14.4\text{ V}$ ; THD = 10 %	-	30	-	W
		$V_S = 14.4\text{ V}$ ; THD = 1 %	-	24	-	W
		$V_S = 14.4\text{ V}$ ; THD = 10 %, 2 $\Omega$	-	55	-	W
		$V_S = 14.4\text{ V}$ ; THD = 1 %, 2 $\Omega$	-	43	-	W
$P_{o\text{ max.}}$	Max. output power <sup>(1)</sup>	$V_S = 14.4\text{ V}$ ; $R_L = 4\ \Omega$	-	50	-	W
		$V_S = 14.4\text{ V}$ ; $R_L = 2\ \Omega$	-	85	-	W
		$V_S = 15.2\text{ V}$ ; $R_L = 4\ \Omega$ (square wave input (2 Vrms))	-	52	-	W
THD	Distortion	$P_o = 4\text{ W}$	-	0.01	0.02	%
$G_v$	Voltage gain	-	25.5	26	26.5	dB
$dG_v$	Channel gain unbalance	-	-1	-	+1	dB
$e_{No}$	Output Noise	"A" Weighted Bw = 20 Hz to 20 kHz	-	40	-	$\mu\text{V}$
			-	50	70	$\mu\text{V}$
SVR	Supply voltage rejection	$f = 100\text{ Hz}$ ; $V_r = 1\text{ Vrms}$	50	70	-	dB
$f_{ch}$	High cut-off frequency	$P_o = 0.5\text{ W}$	100	300	-	kHz
$C_T$	Cross talk	$f = 1\text{ kHz}$ $P_o = 4\text{ W}$	60	80	-	dB
		$f = 10\text{ kHz}$ $P_o = 4\text{ W}$	50	60	-	dB
$A_M$	Mute attenuation	$P_{\text{Oref}} = 4\text{ W}$	80	100	-	dB
<b>Control pin characteristics</b>						
$I_{\text{pin5}}$	Standby pin current	$V_{\text{St-by}} = 0.8\text{ V to }2.2\text{ V}$	-	-	0.5	$\mu\text{A}$
$V_{\text{SB out}}$	Standby out threshold voltage	(Amp: ON)	2.2	-	-	V

**Table 5. Electrical characteristics (continued)**

Symbol	Parameter	Test condition	Min.	Typ.	Max.	Unit
$V_{SB\ in}$	Standby in threshold voltage	(Amp: OFF)	-	-	0.8	V
$V_{M\ out}$	Mute out threshold voltage	(Amp: Play)	2.3	-	-	V
$V_{M\ in}$	Mute in threshold voltage	(Amp: Mute)	-	-	0.8	V
$V_{AM\ in}$	$V_S$ automute threshold	(Amp: Mute) Att $\geq$ 80 dB; $P_{Oref} = 4\ W$	4.5	5	5.5	V
		(Amp: Play) Att $<$ 0.1 dB; $P_O = 0.5\ W$	-	-	6	V
Ipin23	Muting pin current	$V_{MUTE} = 0.8\ V$ (Sourced current)	-	9	14	$\mu A$
<b>HSD section</b>						
$V_{dropout}$	Dropout voltage	$I_O = 0.35\ A$	-	0.25	0.3	V
$I_{prot}$	Current limits	-	400	-	800	mA
<b>Offset detector</b>						
$V_{OFF}$	Detected differential output offset	-	$\pm 2.3$	$\pm 3$	$\pm 3.7$	V
$V_{OFF\_SAT}$	Off detector saturation voltage	$V_o > \pm 3\ V$ , $I_{off\ Det} = 1\ mA$ $0\ V < V_{off\ Det} < 18\ V$	-	0.05	0.1	V
$V_{OFF\_LK}$	Off detector leakage current	$V_o < \pm 1\ V$	-	0	15	$\mu A$
<b>Clipping detector</b>						
$CD_{LK}$	Clip detector high leakage current	Cd off	-	0	1	$\mu A$
$CD_{SAT}$	Clip detector saturation voltage	DC On; $I_{CD} = 1\ mA$	-	0.2	0.4	V
$CD_{THD}$	Clip detector THD level	-	-	1	-	%

1. Saturated square wave output

## 4 Electrical characteristics typical curves

Figure 6. Quiescent current vs. supply voltage

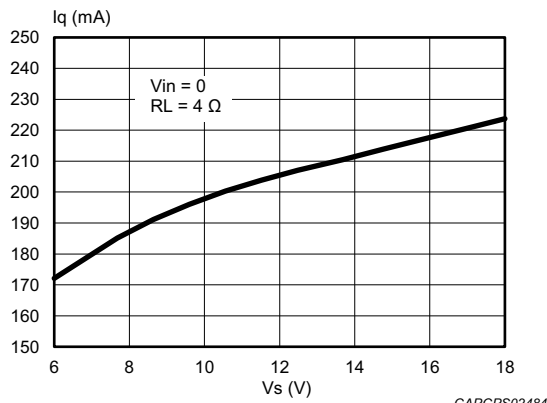

Figure 7. Output power vs. supply voltage (4 Ω)

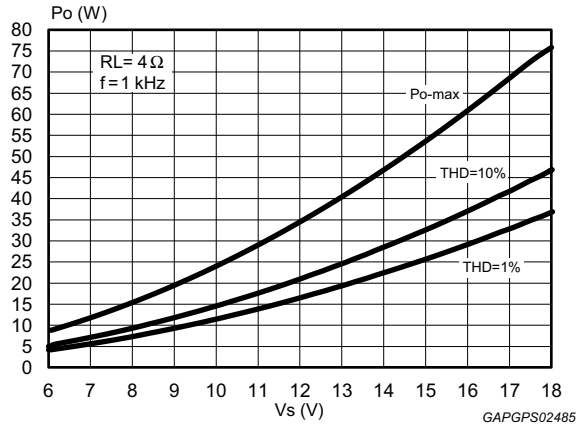

Figure 8. Output power vs. supply voltage (2 Ω)

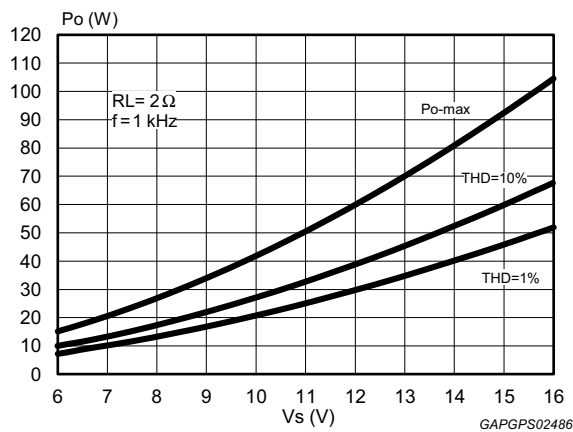

Figure 9. Distortion vs. output power (4 Ω)

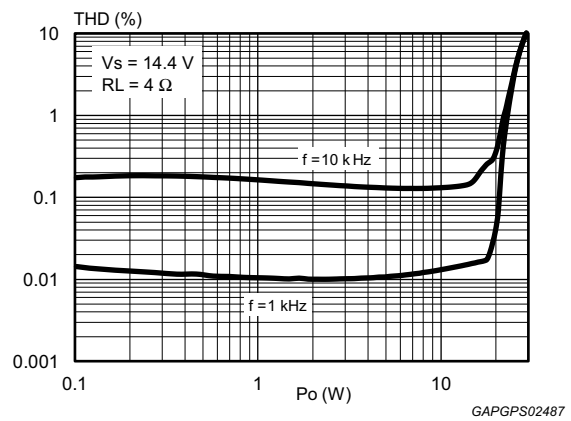

Figure 10. Distortion vs. output power (2 Ω)

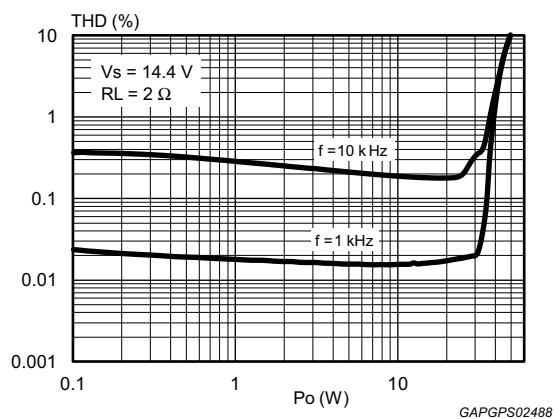

Figure 11. Distortion vs. frequency (4 Ω)

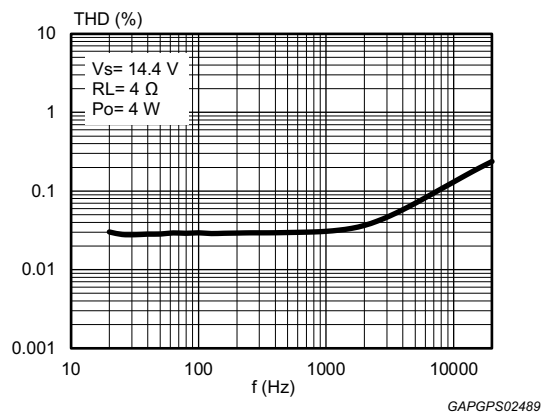

Figure 12. Distortion vs. frequency (2 Ω)

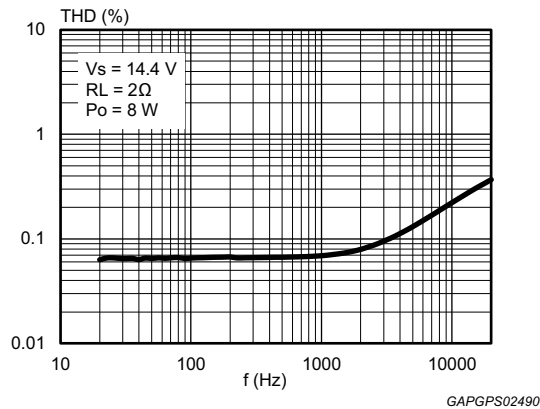

Figure 13. Distortion vs. output power (4 Ω, Vs = 6 V)

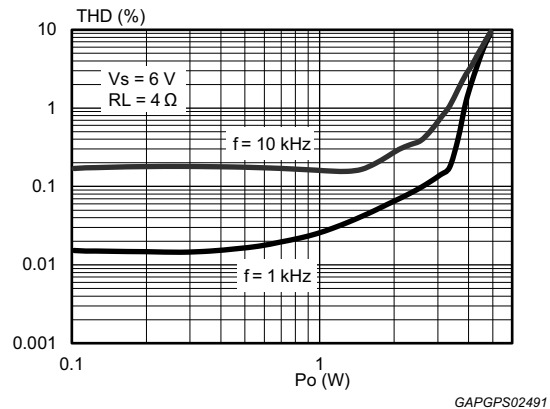

Figure 14. Distortion vs. output power (2 Ω, Vs = 6 V)

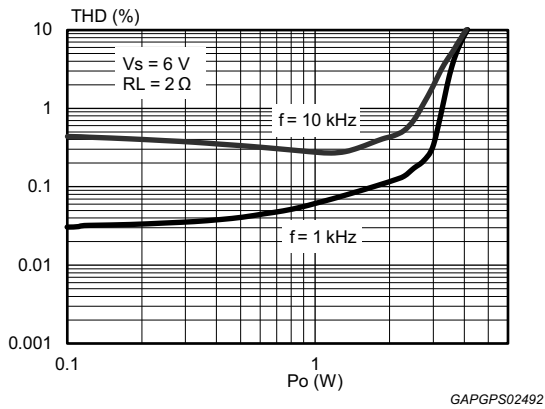

Figure 15. Supply voltage rejection vs. frequency

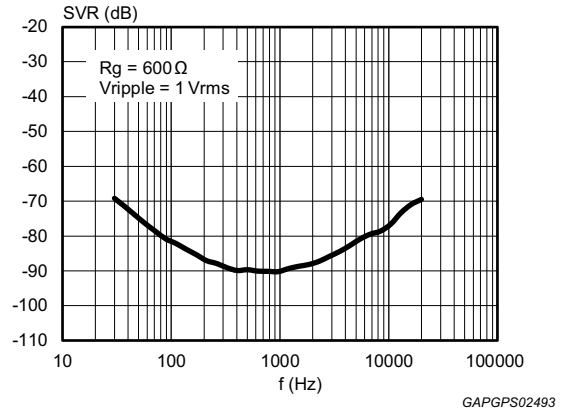

Figure 16. Crosstalk vs. frequency

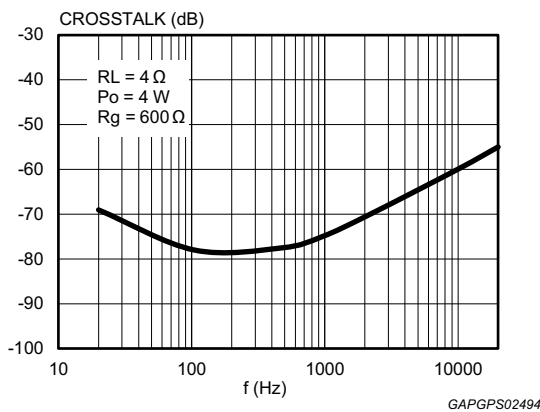
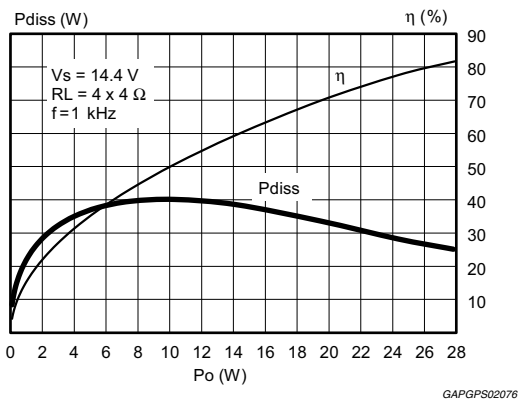
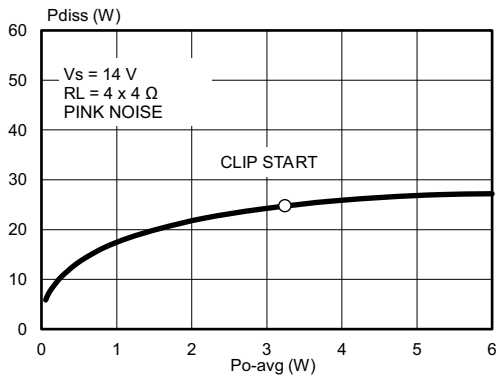

Figure 17. Total power dissipation & efficiency vs. Po (4 Ω, Sine)

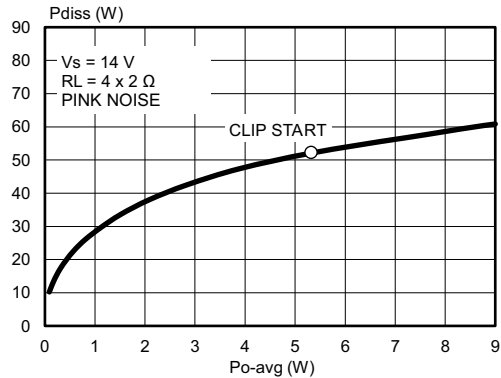

**Figure 18. Power dissipation vs. average output power (4 Ω, audio program simulation)**



GAPGPS02077

**Figure 19. Power dissipation vs. average output power (2 Ω, audio program simulation)**



GAPGPS02078

**Figure 20. ITU R-ARM frequency response, weighting filter for transient pop**

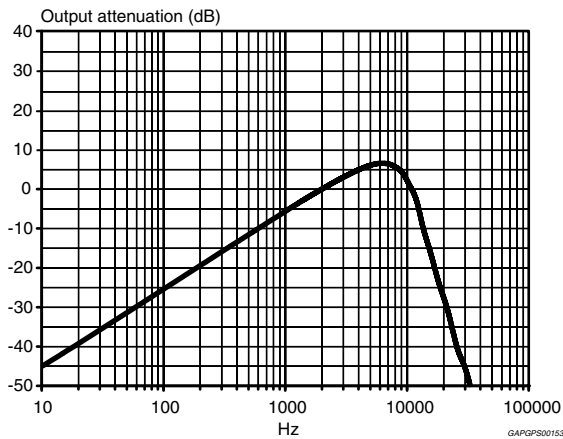

GAPGPS00153

## 5 General information

### 5.1 Operation

The STPA003's inputs are ground-compatible. If the standard value for the input capacitors (0.22  $\mu\text{F}$ ) is adopted, the low frequency cut-off will amount to 16 Hz. For optimum pop performances, the capacitor connected to AC-GND should be four times bigger than input capacitors (see [Figure 2: Standard test and application circuit \(Flexiwatt25 with OD\)](#)).

Standby and mute pins are 3.3 V and 5 V compatible.

RC cells at both mute and stand-by pins have always to be used in order to smooth the transitions for preventing any audible transient noise. A time constant slower than 2.5 V/ms is suggested for the stand-by pin and 0.5 V/ms for the mute pin.

In case the standby function is not used, it could steadily be connected to  $V_s$  through a 470 k $\Omega$  resistor.

The capacitance on SVR sets the start-up and shut-down times and helps to have pop-noise free transitions. Its minimum recommended value is 10  $\mu\text{F}$ . However, to have a fast start-up time, the internal resistor on SVR pin, used to set the time constant, is reduced from 100 k $\Omega$  to 3 k $\Omega$  till voltage on SVR reaches  $V_{CC}/4 - 2V_{BE}$  and then released. In this way the capacitor on SVR is charged very quickly to  $V_{CC}/4$ , as shown in the following figure.

Figure 21. SVR charge diagram

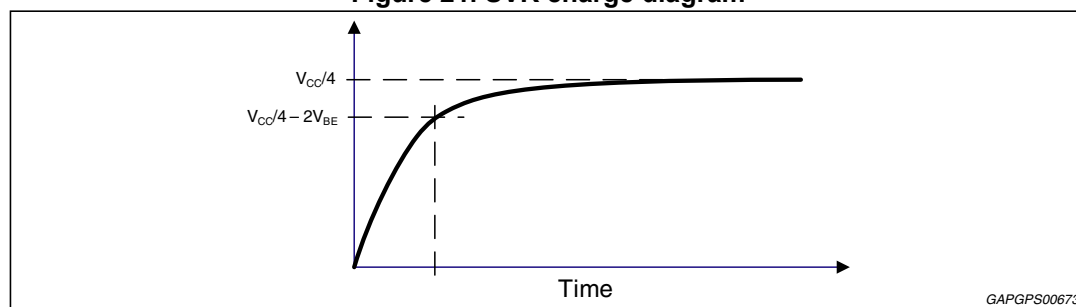

SVR pin accomplishes multiple functions:

- it is used as a reference voltage for input pins ( $V_{CC}/4$ )
- the capacitor connected to SVR helps the supply voltage ripple rejection
- it is used as a reference to generate the half supply voltage for the output

When the amplifier goes in stand-by mode or goes out from this condition, it is suggested to put the amplifier in mute to ensure the absence of audible noise. Then the standby pin can be set to the appropriate value (ground or  $> 2.2$  V) and the capacitance on SVR pin is discharged or charged consequently.



## 5.2 Battery variations

### 5.2.1 Low voltage operation

Most recent OEM specifications require automatic stop for car engine at traffic lights, in order to reduce emissions of polluting substances. The STPA003, thanks to its innovating design, allows a continuous operation when battery falls down. At 6 V it is still fully operational, only the maximum output power is reduced according to the available voltage supply.

If the battery voltage drops below the minimum operating voltage of 6 V the amplifier is fast muted, the capacitor on SVR is discharged and the amplifier restarts when the battery voltage returns to the correct voltage.

### 5.2.2 Cranks

STPA003 can sustain worst case cranks from 16 V to 6 V, continuing to play and without producing any pop noise.

Examples of battery cranking curves are shown below, indicating the shape and duration of allowed battery transitions.

Figure 22. Battery cranking curve example 1

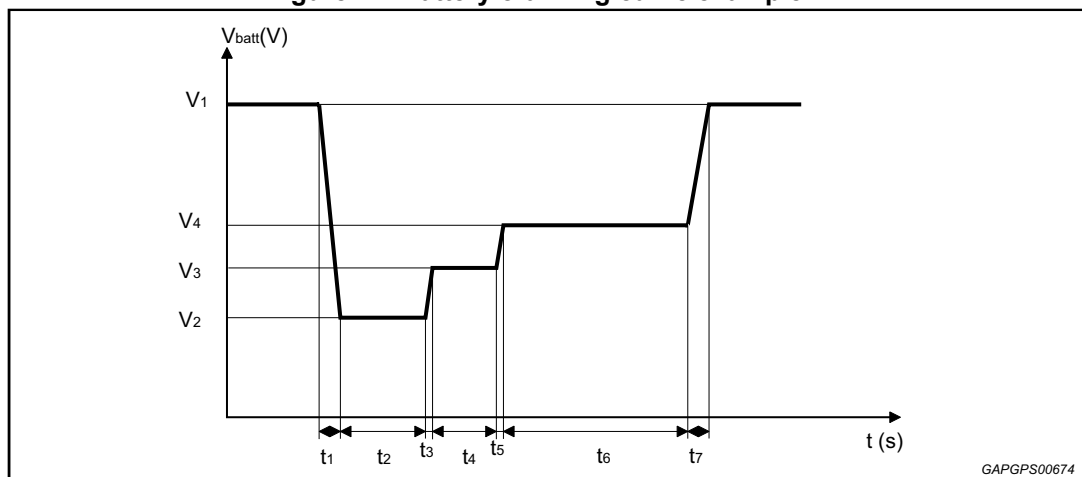

$V_1 = 16\text{ V}; V_2 = 6\text{ V}; V_3 = 7\text{ V}; V_4 = 8\text{ V}$

$t_1 = 2\text{ ms}; t_2 = 50\text{ ms}; t_3 = 5\text{ ms}; t_4 = 300\text{ ms}; t_5 = 10\text{ ms}; t_6 = 1\text{ s}; t_7 = 2\text{ ms}$

Figure 23. Battery cranking curve example 2

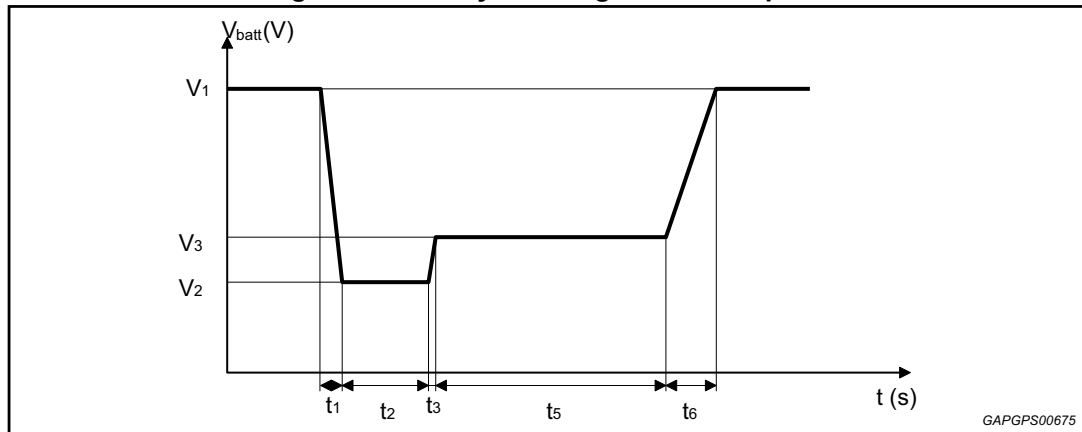

$V1 = 16\text{ V}; V2 = 6\text{ V}; V3 = 7\text{ V}$

$t1 = 2\text{ ms}; t2 = 5\text{ ms}; t3 = 15\text{ ms}; t5 = 1\text{ s}; t6 = 50\text{ ms}$

### 5.2.3 Advanced battery management (hybrid vehicles)

In addition to compatibility with low  $V_{batt}$ , the STPA003 is able to sustain upwards fast battery transitions without causing unwanted audible effects, like pop noise, and without any sound interruption thanks to the innovative circuit topology. In fact, in hybrid vehicles, the engine ignition causes a fast increase of battery voltage which can reach 16 V in less than 10 ms.

Figure 24. Upwards fast battery transitions diagram

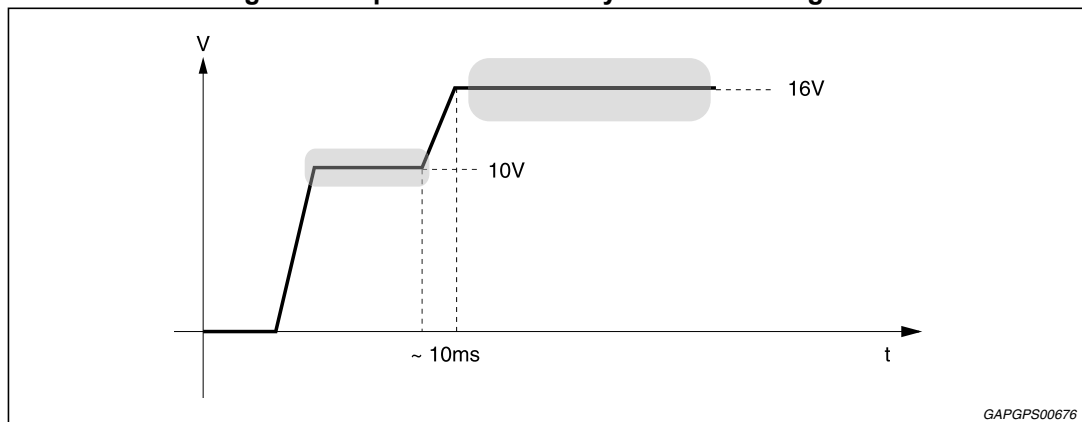

## 5.3 Protections

### 5.3.1 Short circuits and open circuit operation

When the IC detects a short circuit to ground, to  $V_{\text{supply}}$  or across the load, the output of the amplifier is put in three-state (high impedance condition). The power stage remains in this condition until the short is removed.

In case of short circuit to ground or  $V_{\text{cc}}$ , the amplifier exits from the three-state condition only when the output returns inside the limits imposed by an internal voltage comparator.

When a short across the load is present, the power stage sees an over-current and is brought in protection mode for 100  $\mu\text{s}$ . After this time, if the short circuit condition is removed the amplifier returns to play, otherwise the high impedance state is maintained and the check is repeated every 100  $\mu\text{s}$ .

Disconnection of load (open load condition) doesn't damage the amplifier, which continues to play.

### 5.3.2 Over-voltage and load dump protection

When the battery voltage is higher than 19 V, the amplifier is switched to a high impedance state. It stops playing till the supply voltage returns in the permitted range.

The amplifier is protected against load dump surges having amplitude as high as 50 V and a rising time lower than 5 ms (see [Figure 25](#)).

**Figure 25. Load dump protection diagram**

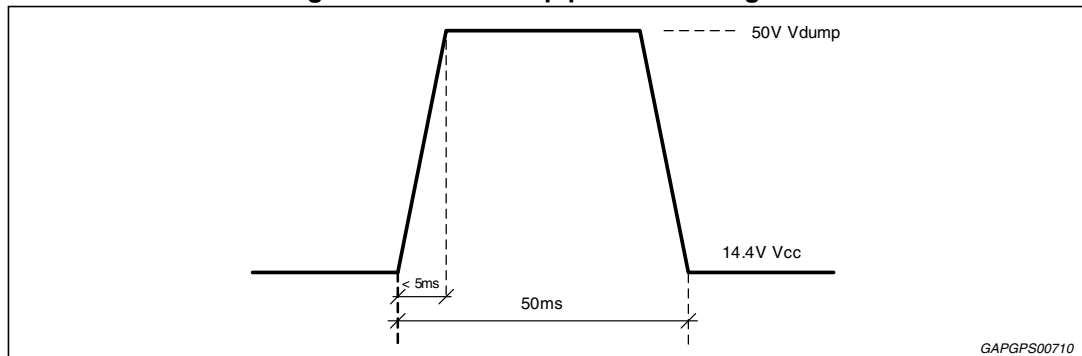

### 5.3.3 Thermal protection

If the junction temperature of the IC reaches  $T_j = 150\text{ }^\circ\text{C}$ , a smooth mute is applied to reduce output power and limit power dissipation. If this is not enough and the junction temperature continues to increase, the amplifier is switched off when reaches the maximum temperature of  $170\text{ }^\circ\text{C}$ .

**Figure 26. Thermal protection diagram**

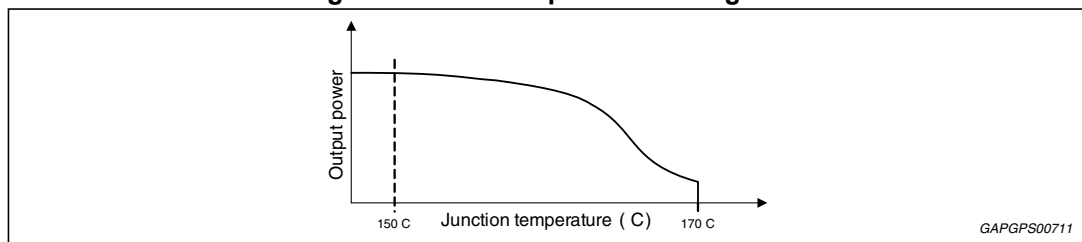

## 5.4 Warnings

### 5.4.1 DC offset detection (OD pin)

The STPA003 integrates a DC offset detector to avoid that an anomalous input DC offset is multiplied by the amplifier gain producing a dangerous large offset at the output. In fact an output offset may lead to speakers damage for overheating. To correctly detect a DC offset, the power amplifier has to be un-muted with no input signal.

When the differential output voltage is out of a window comparator with thresholds  $\pm 3\text{ V}$  (typ), the OD pin is pulled down.

### 5.4.2 Clipping detection and diagnostics (CD-DIAG pin)

When clipping occurs, the output signal is distorted. If the signal distortion on one of the output channels exceeds 1 %, the CD-DIAG pin is pulled down. This information can be sent to an audio processor in order to reduce the input signal of the amplifier and reduce the clipping.

A short to ground and short to  $V_{cc}$  is signaled by CD-DIAG. This pin is pulled down to 0 V till these shorts are present to inform the user a protection occurred.

CD-DIAG acts also as thermal warning. In fact every time  $T_j$  exceeds  $140\text{ }^\circ\text{C}$ , it is pulled down to notify this occurrence.

Figure 27. Audio section waveforms

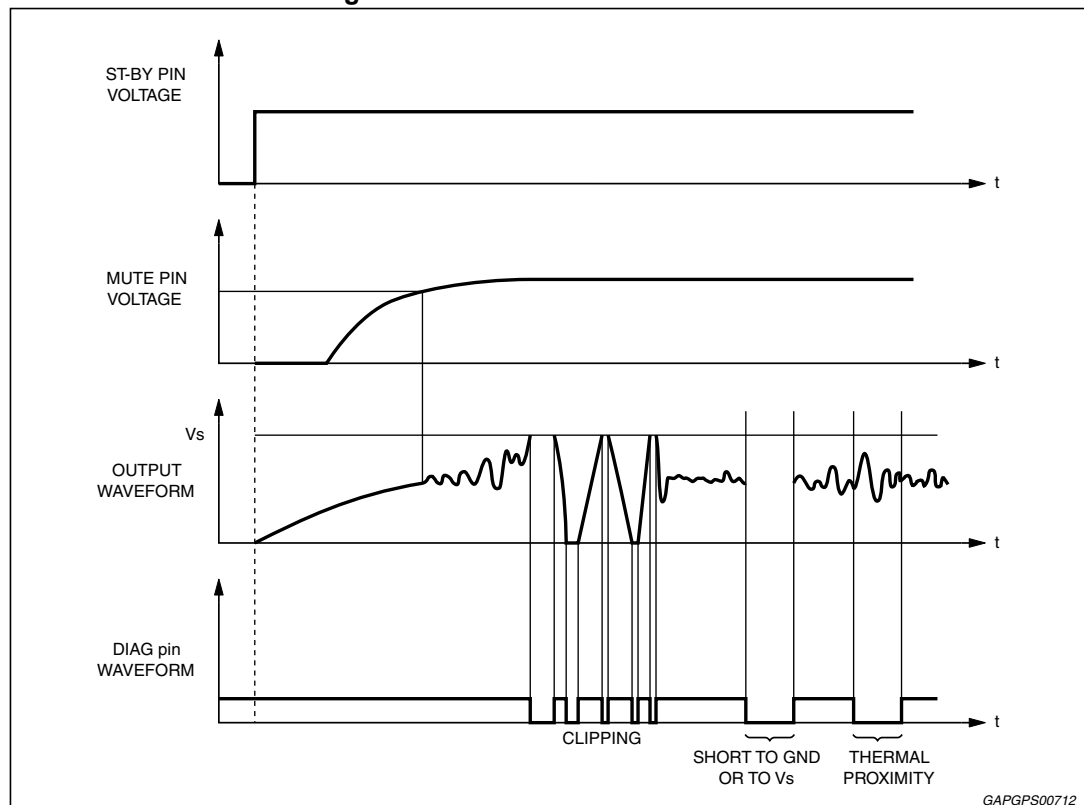

## 5.5 Heat sink definition

Assuming we have a maximum dissipated power of 26 W (e.g. in the worst case situation of frequent clipping occurrence), considering  $T_j$  max is 150 °C and assuming ambient temperature is 70 °C, the available temperature gap for a correct dissipation is 80 °C. This means the thermal resistance of the system  $R_{th}$  has to be  $80\text{ °C}/26\text{ W} = 3\text{ °C/W}$ .

The junction to case thermal resistance is 1 °C/W. So the heat sink thermal resistance should be approximately 2 °C/W. This would avoid any thermal shutdown occurrence even after long-term and full-volume operation.

# 6 Package information

In order to meet environmental requirements, ST offers these devices in different grades of ECOPACK® packages, depending on their level of environmental compliance. ECOPACK® specifications, grade definitions and product status are available at: [www.st.com](http://www.st.com).

ECOPACK® is an ST trademark.

**Figure 28. Flexiwatt25 (vertical) mechanical data and package dimensions**

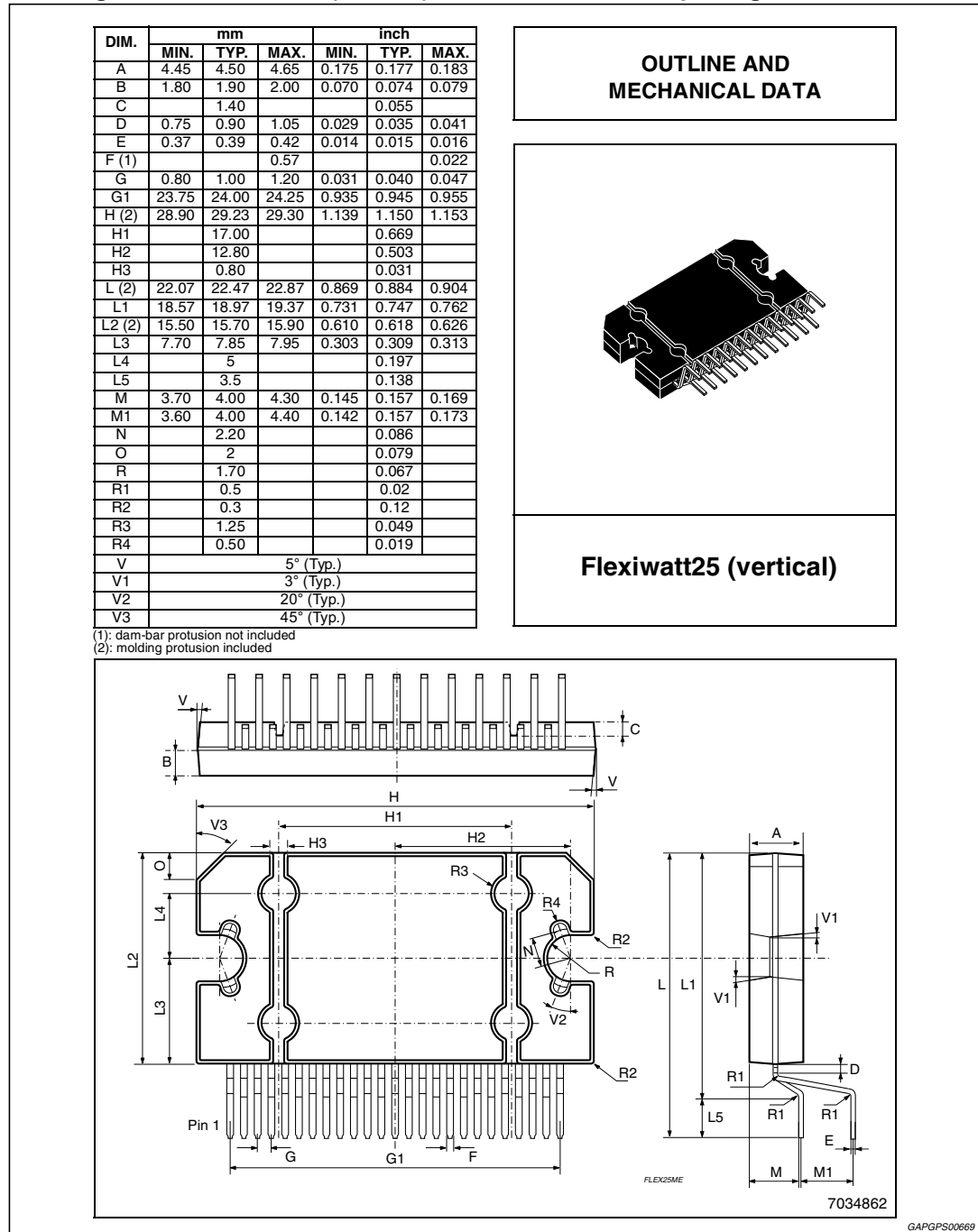
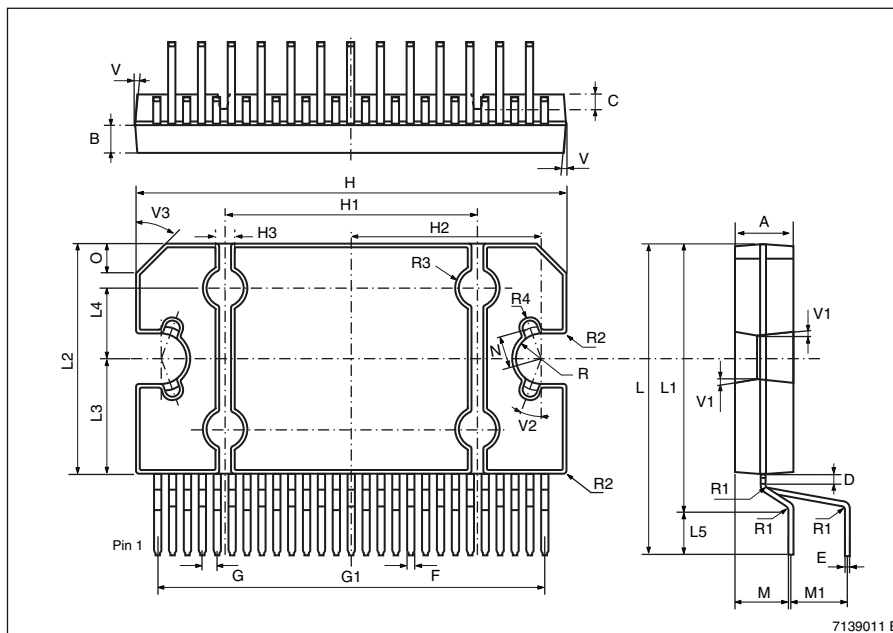
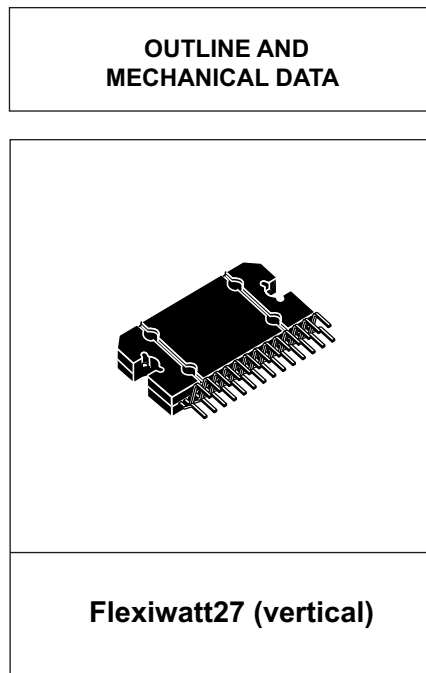

Figure 29. Flexiwatt27 (Vertical) mechanical data and package dimensions

DIM.	mm			inch		
	MIN.	TYP.	MAX.	MIN.	TYP.	MAX.
A	4.45	4.50	4.65	0.175	0.177	0.183
B	1.80	1.90	2.00	0.070	0.074	0.079
C		1.40			0.055	
D	0.75	0.90	1.05	0.029	0.035	0.041
E	0.37	0.39	0.42	0.014	0.015	0.016
F <sup>(1)</sup>			0.57		0.022	
G	0.80	1.00	1.20	0.031	0.040	0.047
G1	25.75	26.00	26.25	1.014	1.023	1.033
H <sup>(2)</sup>	28.90	29.23	29.30	1.139	1.150	1.153
H1		17.00			0.669	
H2		12.80			0.503	
H3		0.80			0.031	
L <sup>(2)</sup>	22.07	22.47	22.87	0.869	0.884	0.904
L1	18.57	18.97	19.37	0.731	0.747	0.762
L2 <sup>(2)</sup>	15.50	15.70	15.90	0.610	0.618	0.626
L3	7.70	7.85	7.95	0.303	0.309	0.313
L4		5			0.197	
L5		3.5			0.138	
M	3.70	4.00	4.30	0.145	0.157	0.169
M1	3.60	4.00	4.40	0.142	0.157	0.173
N		2.20			0.086	
O		2			0.079	
R		1.70			0.067	
R1		0.5			0.02	
R2		0.3			0.12	
R3		1.25			0.049	
R4		0.50			0.019	
V	5° (Typ.)					
V1	3° (Typ.)					
V2	20° (Typ.)					
V3	45° (Typ.)					

(1): dam-bar protrusion not included; (2): molding protrusion included.



## 7 Revision history

**Table 6. Document revision history**

Date	Revision	Changes
11-Jul-2014	1	Initial release.



**Please Read Carefully:**

Information in this document is provided solely in connection with ST products. STMicroelectronics NV and its subsidiaries ("ST") reserve the right to make changes, corrections, modifications or improvements, to this document, and the products and services described herein at any time, without notice.

All ST products are sold pursuant to ST's terms and conditions of sale.

Purchasers are solely responsible for the choice, selection and use of the ST products and services described herein, and ST assumes no liability whatsoever relating to the choice, selection or use of the ST products and services described herein.

No license, express or implied, by estoppel or otherwise, to any intellectual property rights is granted under this document. If any part of this document refers to any third party products or services it shall not be deemed a license grant by ST for the use of such third party products or services, or any intellectual property contained therein or considered as a warranty covering the use in any manner whatsoever of such third party products or services or any intellectual property contained therein.

**UNLESS OTHERWISE SET FORTH IN ST'S TERMS AND CONDITIONS OF SALE ST DISCLAIMS ANY EXPRESS OR IMPLIED WARRANTY WITH RESPECT TO THE USE AND/OR SALE OF ST PRODUCTS INCLUDING WITHOUT LIMITATION IMPLIED WARRANTIES OF MERCHANTABILITY, FITNESS FOR A PARTICULAR PURPOSE (AND THEIR EQUIVALENTS UNDER THE LAWS OF ANY JURISDICTION), OR INFRINGEMENT OF ANY PATENT, COPYRIGHT OR OTHER INTELLECTUAL PROPERTY RIGHT.**

**ST PRODUCTS ARE NOT DESIGNED OR AUTHORIZED FOR USE IN: (A) SAFETY CRITICAL APPLICATIONS SUCH AS LIFE SUPPORTING, ACTIVE IMPLANTED DEVICES OR SYSTEMS WITH PRODUCT FUNCTIONAL SAFETY REQUIREMENTS; (B) AERONAUTIC APPLICATIONS; (C) AUTOMOTIVE APPLICATIONS OR ENVIRONMENTS, AND/OR (D) AEROSPACE APPLICATIONS OR ENVIRONMENTS. WHERE ST PRODUCTS ARE NOT DESIGNED FOR SUCH USE, THE PURCHASER SHALL USE PRODUCTS AT PURCHASER'S SOLE RISK, EVEN IF ST HAS BEEN INFORMED IN WRITING OF SUCH USAGE, UNLESS A PRODUCT IS EXPRESSLY DESIGNATED BY ST AS BEING INTENDED FOR "AUTOMOTIVE, AUTOMOTIVE SAFETY OR MEDICAL" INDUSTRY DOMAINS ACCORDING TO ST PRODUCT DESIGN SPECIFICATIONS. PRODUCTS FORMALLY ESCC, QML OR JAN QUALIFIED ARE DEEMED SUITABLE FOR USE IN AEROSPACE BY THE CORRESPONDING GOVERNMENTAL AGENCY.**

Resale of ST products with provisions different from the statements and/or technical features set forth in this document shall immediately void any warranty granted by ST for the ST product or service described herein and shall not create or extend in any manner whatsoever, any liability of ST.

ST and the ST logo are trademarks or registered trademarks of ST in various countries.

Information in this document supersedes and replaces all information previously supplied.

The ST logo is a registered trademark of STMicroelectronics. All other names are the property of their respective owners.

© 2014 STMicroelectronics - All rights reserved

STMicroelectronics group of companies

Australia - Belgium - Brazil - Canada - China - Czech Republic - Finland - France - Germany - Hong Kong - India - Israel - Italy - Japan - Malaysia - Malta - Morocco - Philippines - Singapore - Spain - Sweden - Switzerland - United Kingdom - United States of America

[www.st.com](http://www.st.com)





Компания «ЭлектроПласт» предлагает заключение долгосрочных отношений при поставках импортных электронных компонентов на взаимовыгодных условиях!

Наши преимущества:

- Оперативные поставки широкого спектра электронных компонентов отечественного и импортного производства напрямую от производителей и с крупнейших мировых складов;
- Поставка более 17-ти миллионов наименований электронных компонентов;
- Поставка сложных, дефицитных, либо снятых с производства позиций;
- Оперативные сроки поставки под заказ (от 5 рабочих дней);
- Экспресс доставка в любую точку России;
- Техническая поддержка проекта, помощь в подборе аналогов, поставка прототипов;
- Система менеджмента качества сертифицирована по Международному стандарту ISO 9001;
- Лицензия ФСБ на осуществление работ с использованием сведений, составляющих государственную тайну;
- Поставка специализированных компонентов (Xilinx, Altera, Analog Devices, Intersil, Interpoint, Microsemi, Aeroflex, Peregrine, Syfer, Eurofarad, Texas Instrument, Miteq, Cobham, E2V, MA-COM, Hittite, Mini-Circuits, General Dynamics и др.);

Помимо этого, одним из направлений компании «ЭлектроПласт» является направление «Источники питания». Мы предлагаем Вам помощь Конструкторского отдела:

- Подбор оптимального решения, техническое обоснование при выборе компонента;
- Подбор аналогов;
- Консультации по применению компонента;
- Поставка образцов и прототипов;
- Техническая поддержка проекта;
- Защита от снятия компонента с производства.



#### Как с нами связаться

**Телефон:** 8 (812) 309 58 32 (многоканальный)

**Факс:** 8 (812) 320-02-42

**Электронная почта:** [org@eplast1.ru](mailto:org@eplast1.ru)

**Адрес:** 198099, г. Санкт-Петербург, ул. Калинина, дом 2, корпус 4, литера А.