

MC12311



Package Information

Case nnnn-xx
LGA-60 [8x8 mm]

Ordering Information

Device	Device Marking	Package
MC12311	MC12311	LGA-60

MC12311

Highly-integrated, cost-effective single-package solution for the sub-1 GHz, Wireless MBUS Standard

1 Introduction

The MC12311 is a highly-integrated, cost-effective, system-in-package (SIP), sub-1GHz wireless node solution with an FSK, GFSK, MSK, or OOK modulation-capable transceiver and low-power HCS08 8-bit microcontroller. The highly integrated RF transceiver operates over a wide frequency range including 315 MHz, 433 MHz, 470 MHz, 868 MHz, 915 MHz, 928 MHz, and 955 MHz in the license-free Industrial, Scientific and Medical (ISM) frequency bands. This configuration allows users to minimize the use of external components.

The MC12311 is targeted for the following low-power wireless applications:

- Automated Meter Reading
- Wireless Sensor Networks
- Home and Building Automation
- Wireless Alarm and Security Systems
- Industrial Monitoring and Control
- Wireless MBUS Standard (EN13757-4:2005)

Contents

1 Introduction	1
2 Features	2
3 Software Solutions	4
4 System-in-Package Sub-1 GHz Wireless Node	5
5 MC12311 Pin Assignments and Connections	8
6 System and Power Management	12
7 Development Environment	14
8 System Electrical Specification	14
9 Typical Applications Circuit	34
10 Mechanical Drawings	37

Freescall supplements the MC12311 with tools and software that include hardware evaluation and development boards, software development IDE and applications, drivers, custom PHY usable with Freescall's IEEE 802.15.4 compatible MAC, SMAC and an available wireless MBUS solution.

2 Features

This section provides a simplified block diagram and highlights MC12311 features.

2.1 Block Diagram

Figure 1 shows a simplified block diagram of the MC12311.

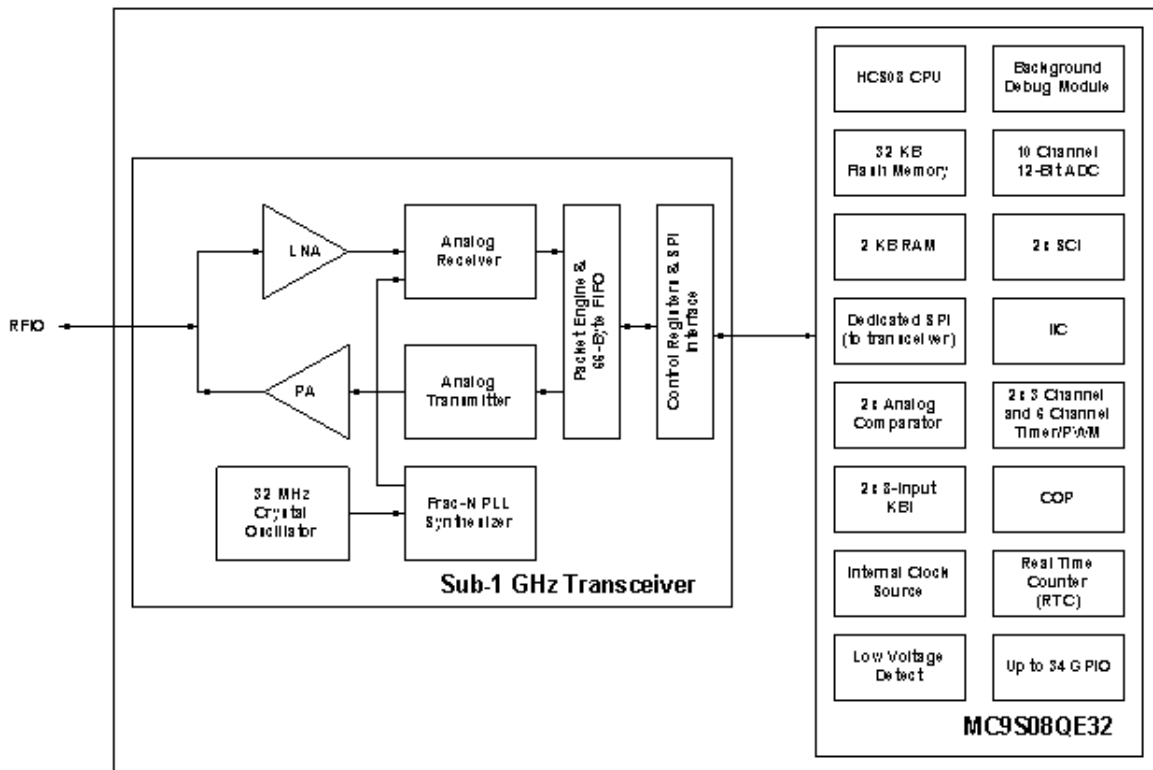

Figure 1. MC12311 Simplified Block Diagram

2.2 Features Summary

- RF Transceiver Features
 - High Sensitivity: down to -120 dBm at 1.2 kbps
 - High Selectivity: 16-tap FIR Channel Filter
 - Bullet-proof front end: IIP3 = -18 dBm, IIP2 = +35 dBm, 80 dB Blocking Immunity, no Image Frequency response
 - Low current: Rx = 16mA, 100nA register retention
 - Programmable Pout : -18 to +17 dBm in 1 dB steps
 - Constant RF performance over voltage range of chip

- FSK bit rates up to 300 kbps
- Fully integrated synthesizer with a resolution of 61 Hz
- FSK, GFSK, MSK, GMSK and OOK modulations
- Built-in Bit Synchronizer performing Clock recovery
- Incoming Sync Word Recognition
- Automatic RF Sense with ultra-fast AFC
- Packet engine with CRC, AES-128 encryption and 66-byte FIFO
- Built-in temperature sensor and Low battery indicator
- 32 MHz crystal oscillator clock source
- 9S08QE32 MCU Features
 - 8-Bit HCS08 Central Processor Unit (CPU) with CPU clock rate up to:
 - 50.33 MHz at 3.6 V to 2.4V
 - 40 MHz at 2.4V to 2.1V
 - 20 MHz at 2.1V to 1.8V
 - HC08 instruction set with added BGND instruction
 - Support for up to 32 interrupt/reset sources
 - 32 KB Flash and 2 KB RAM
 - Low power modes (Wait plus Stop2 and Stop3 modes)
 - Dedicated serial peripheral interface (SPI) connected internally to sub-1 GHz transceiver
 - Multiple clock source options
 - Internal clock generator (ICG) with 243 kHz oscillator that has +/-0.2% trimming resolution and +/-0.5% deviation across voltage.
 - Startup oscillator of approximately 8 MHz
 - External crystal or resonator
 - External source from modem clock for very high accuracy source or system low-cost option
 - In-circuit debug and FLASH programming available via on-chip background debug module (BDM)
 - System protection features
 - Programmable low voltage interrupt (LVI)
 - Optional watchdog timer (COP)
 - Illegal opcode detection
 - Peripherals
 - ADC — 10-channel, 12-bit resolution; 2.5 ms conversion time; automatic compare function; 1.7 mV/°C temperature sensor; internal bandgap reference channel; operation in stop3; fully functional from 3.6 V to 1.8 V
 - ACMPx — Two analog comparators with selectable interrupt on rising, falling, or either edge of comparator output; compare option to fixed internal bandgap reference voltage; outputs can be optionally routed to TPM module; operation in stop3



- SCIx — Two serial communications interface modules with optional 13-bit break. Full duplex non-return to zero (NRZ); LIN master extended break generation; LIN slave extended break detection; wake on active edge
- IIC — One IIC; up to 100 kbps with maximum bus loading; multi-master operation; programmable slave address; interrupt driven byte-by-byte data transfer; supports broadcast mode and 10-bit addressing
- TPMx — One 6-channel (TPM3) and two 3-channel (TPM1 and TPM2); selectable input capture, output compare, or buffered edge- or center-aligned PWM on each channel;
- RTC — (Real-time counter) 8-bit modulus counter with binary or decimal based prescaler; external clock source for precise time base, time-of-day, calendar or task scheduling functions; free running on-chip low power oscillator (1 kHz) for cyclic wake-up without external components; runs in all MCU modes
- KBI — Two 8-bit port keyboard interrupt modules
- Input/Output
 - Up to 33 GPIO including dedicated GPIO supporting transceiver
 - 13 KBI interrupts with selectable polarity
 - Hysteresis and configurable pullup device on all input pins; Configurable slew rate and drive strength on all output pins.
- 1.8 V to 3.6 V operating voltage with on-chip voltage regulators
- Temperature range of –40 °C to 85 °C
- 60-pin LGA (8x8 mm) Package

3 Software Solutions

Freescale will support the MC12311 platform with several software solutions:

- SMAC (Simple Media Access Controller) - This codebase provides simple communication and test apps based on drivers/PHY utilities available as source code. This environment is useful for hardware and RF debug, hardware standards certification, and developing proprietary applications.
- IEEE 802.15.4 MAC with custom PHY layer - The Freescale MAC is a robust, mature codebase useful for developing networking solutions. Freescale is implementing an IEEE 802.15.4 MAC-compatible custom sub-1 GHz PHY template that can be used across different frequency bands. This capability allows users to build powerful networking solutions on a known, stable codebase.
- Wireless MBUS stack - Freescale is porting an existing wireless MBUS codebase to the MC12311 platform which will be available through an external partner.

The Freescale MC12311 solutions are provided through a powerful software environment called the Freescale BeeKit Wireless Connectivity Toolkit. BeeKit is a comprehensive codebase of wireless networking libraries, application templates, and sample applications. The BeeKit Graphical User Interface (GUI), part of the BeeKit Wireless Connectivity Toolkit, allows users to create, modify, and update various wireless networking implementations. The MC12311 products are available as codebases within BeeKit; for the wireless MBUS stack, BeeKit will have simple demo apps only.

4 System-in-Package Sub-1 GHz Wireless Node

The MC12311 brings together a transceiver chip and an MCU chip on a single substrate to provide a small footprint, cost-effective sub-1 GHz wireless node. The transceiver is controlled by the MCU through a dedicated SPI interface. The SPI bus interface and some status signals are connected onboard the substrate to eliminate the need for external connections.

4.1 RF Transceiver

The transceiver (see [Figure 2](#)) is a single-chip integrated circuit ideally suited for today's high performance ISM band RF applications. Its advanced features set, including state of the art packet engine, greatly simplifies system design while the high level of integration reduces the external RF component bill of material (BOM) to a handful of passive de-coupling and matching components. It is intended for use as a high-performance, low-cost FSK and OOK RF transceiver for robust, frequency agile, half-duplex bi-directional RF links.

The MC12311 is intended for applications over a wide frequency range, including the 433 MHz and 868 MHz European and the 902-928 MHz North American ISM bands. Coupled with a link budget in excess of 135 dB, the transceiver advanced system features include a 66 byte TX/RX FIFO, configurable automatic packet handler, listen mode, temperature sensor and configurable DIOs which greatly enhance system flexibility while at the same time significantly reducing MCU requirements. The transceiver complies with both ETSI and FCC regulatory requirements.

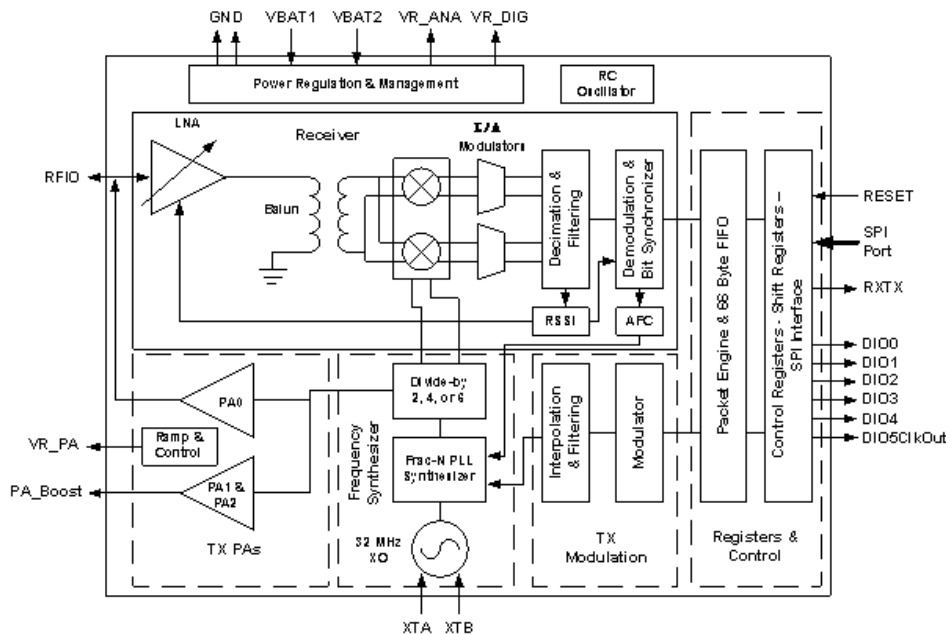
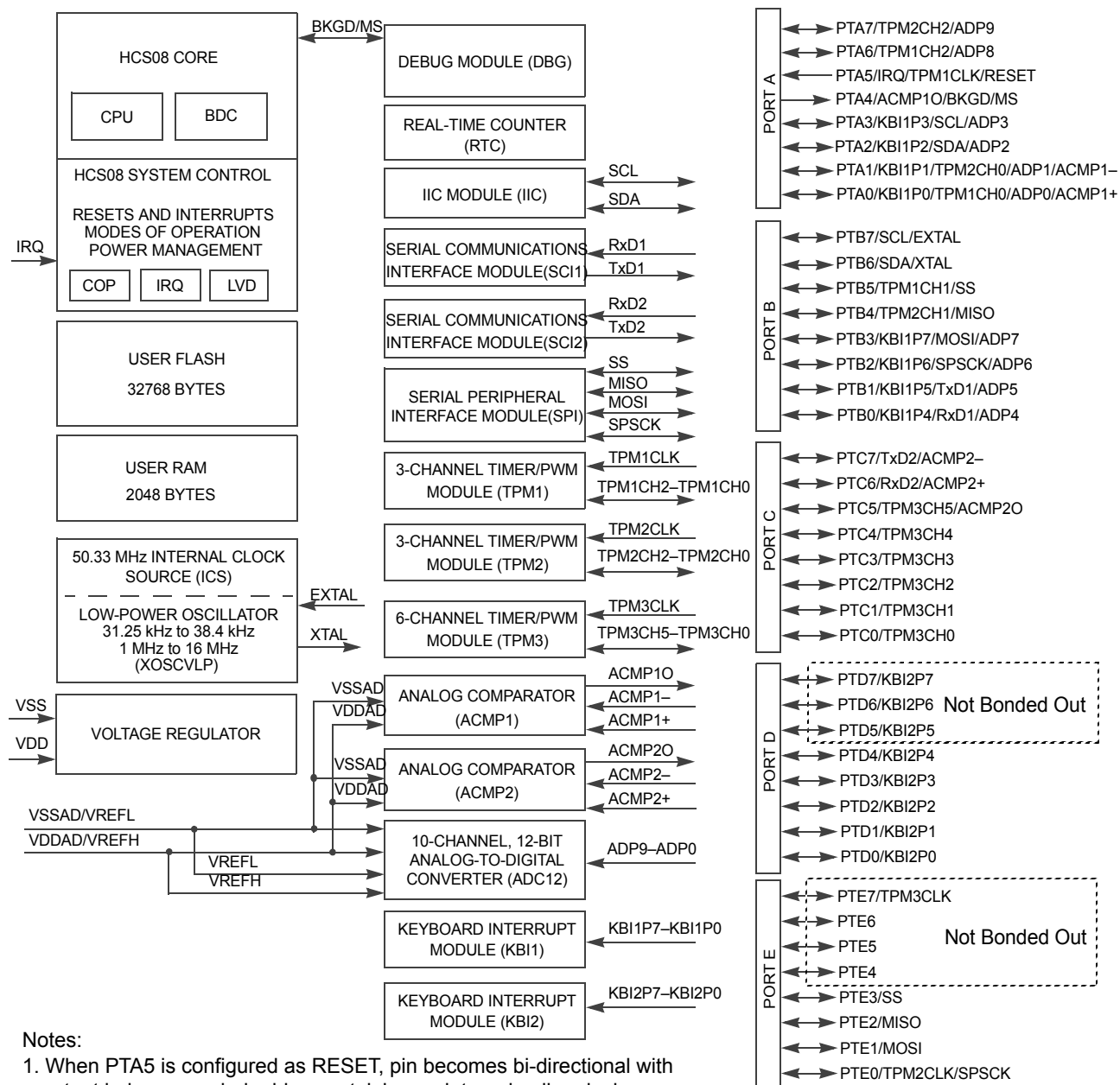

Figure 2. MC12311 Transceiver Block Diagram

The major RF communication parameters of the MC12311 transceiver are programmable and most can be dynamically set. This feature offers the unique advantage of programmable narrow-band and wide-band communication modes without the need to modify external components. The transceiver is also optimized for low power consumption while offering high RF output power and channelized operation.

4.2 9S08QE32 MCU

The onboard 9S08QE32 MCU integrated circuit features an HC08 8-bit CPU, 2 KB RAM, 32 KB Flash memory, and a rich set of peripherals (see Section 2.2, “Features Summary”). The RF transceiver is controlled through the MCU SPI port which is dedicated to the RF device interface. Two of the transceiver status IO lines are also directly connected to the MCU GPIO to monitor the transceiver operation. In addition, the transceiver reset and additional status can be connected to the MCU through external connections.



Notes:

1. When PTA5 is configured as RESET, pin becomes bi-directional with output being open-drain drive containing an internal pullup device.
2. When PTA4 is configured as BKGD, pin becomes bi-directional.
3. Pins PTD7-PTD5 and PTE7-PTE4 not bonded out.

Figure 3. MC12311 MCU Block Diagram

Operational modes of the MC12311 are determined by the software running on the MCU. The 9S08QE32 itself has its normal run mode as well as two low power modes (Stop2 and Stop3). The MCU in turn sets the operational mode of the transceiver which include sleep, standby, and radio operational modes.

Two common application scenarios are:

- Low power, battery-operated standalone wireless node - a common example of this configuration would be a remote sensor monitor. The wireless node programmed for standalone operation, typically has a low active-mode duty cycle, and is designed for long battery life, i.e., lowest power.
- Communication channel to a higher level controller - in this example, the wireless node implements the lower levels of a communications stack and is subordinate to the primary controller. Typically the MC12311 is connected to the controller through a command channel implemented via a UART/SCI port or other serial communication port.

4.3 System Clock Configuration

The MC12311 device allows for a wide array of system clock configurations:

- Pins are provided for a separate external clock source for the MCU. The external clock source can be derived from a crystal oscillator or from an external clock source
- Pins are provided for a 32 MHz crystal for the transceiver reference clock source (required)
- The transceiver can be programmed to provide a ClkOut programmable frequency clock output that can be used as an external source to the CPU. As a result, a single crystal system clock solution is possible (see [Figure 4](#)).
- The MCU provides a trimmable internal reference clock and also supports an external clock source. An optional onboard frequency locked loop (FLL) can be used with either clock source to support a CPU clock as high as 50 Mhz at 3.6 V to 2.4 V VDD.

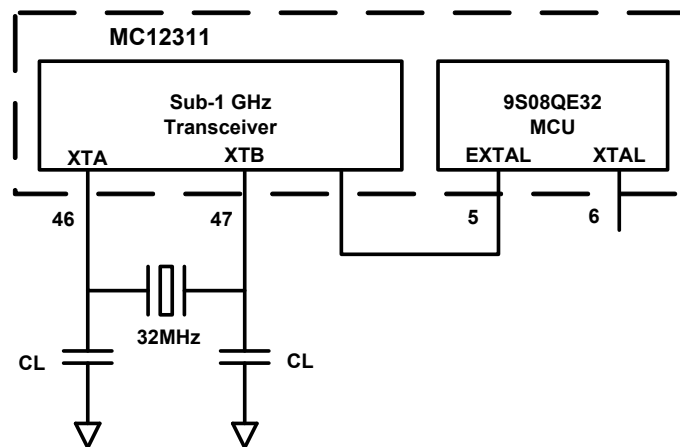

Figure 4. MC12311 Single Crystal System Clock Connection

5 MC12311 Pin Assignments and Connections

Figure 5 shows the MC12311 pinout.

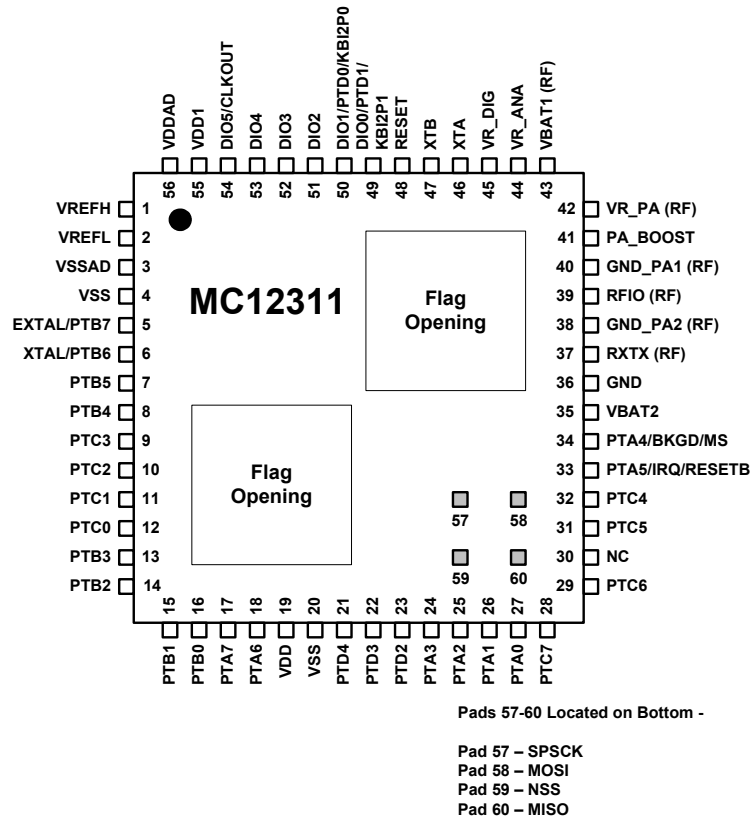

Figure 5. MC12311 Pinout (Top View)

5.1 Pin Definitions

Table 1 details the MC12311 pinout and functionality.

Table 1. Pin Function Description

Pin #	Pin Name	Type	Description	Functionality
1	VREFH	Input	MCU high reference voltage for ATD	
2	VREFL	Input	MCU low reference voltage for ATD	
3	VSSAD	Power Input	MCU ADC Ground	Connect to ground
4	VSS	Power Input	MCU Ground	Connect to ground
5	EXTAL/SCL/PTB7 ¹	Input / Digital Input/Output	MCU Crystal Oscillator input / IIC bus clock / Port B Bit 7	<ul style="list-style-type: none"> Normally used as MCU clock source Driven from transceiver ClkOut (DIO5)
6	XTAL/SDA/PTB6 ¹	Output / Digital Input/Output	MCU Crystal Oscillator output / IIC bus data / Port B Bit 6	

Table 1. Pin Function Description (continued)

Pin #	Pin Name	Type	Description	Functionality
7	PTB5/TPM1CH1 ²	Digital Input/Output	MCU Port B Bit 5 / TPM1 Channel 1	
8	PTB4/TPM2CH1 ²	Digital Input/Output	MCU Port B Bit 4 / TPM2 Channel 1	
9	PTC3/TPM3CH3	Digital Input/Output	MCU Port C Bit 3 / TPM3 Channel 3	
10	PTC2/TPM3CH2	Digital Input/Output	MCU Port C Bit 2 / TPM3 Channel 2	
11	PTC1/TPM3CH1	Digital Input/Output	MCU Port C Bit 1 / TPM3 Channel 1	
12	PTC0/TPM3CH0	Digital Input/Output	MCU Port C Bit 0 / TPM3 Channel 0	
13	PTB3/KBI1P7/ ADP7 ²	Digital Input/Output / Analog Input	MCU Port B Bit 3 / KBI1 Input Bit 7 / ADC Analog Channel 7	
14	PTB2/KBI1P6/ ADP6 ²	Digital Input/Output / Analog Input	MCU Port B Bit 2 / KBI1 Input Bit 6 / ADC Analog Channel 6	
15	PTB1/KBI1P5/TxD1 /ADP5	Digital Input/Output / Analog Input	MCU Port B Bit 1 / KBI1 Input Bit 5 / SC11 TxD / ADC Analog Channel 5	
16	PTB0/KBI1P4/ RXD1/ADP4	Digital Input/Output / Analog Input	MCU Port B Bit 0 / KBI1 Input Bit 4 / SC11 RXD / ADC Analog Channel 4	
17	PTA7/TPM2CH2/ ADP9	Digital Input/Output / Analog Input	MCU Port A Bit 7 / TPM2 Channel 2 / ADC Analog Channel 9	
18	PTA6/TPM1CH2/ ADP8	Digital Input/Output / Analog Input	MCU Port A Bit 6 / TPM1 Channel 2 / ADC Analog Channel 8	
19	VDD	Power Input	MCU VDD	Connect to MC12311 VDD supply
20	VSS	Power Input	MCU Ground	Connect to ground
21	PTD4/KBI2P4	Digital Input/Output	MCU Port D Bit 4 / KBI2 Input Bit 4	
22	PTD3/KBI2P3	Digital Input/Output	MCU Port D Bit 3 / KBI2 Input Bit 3	
23	PTD2/KBI2P2	Digital Input/Output	MCU Port D Bit 2 / KBI2 Input Bit 2	
24	PTA3/KBI1P3/ SCL/ADP3 ¹	Digital Input/Output / Analog Input	MCU Port A Bit 3 / KBI1 Input Bit 3 / IIC bus clock / ADC Analog Channel 3	

Table 1. Pin Function Description (continued)

Pin #	Pin Name	Type	Description	Functionality
25	PTA2/KBI1P2/ SDA/ADP2 ²	Digital Input/Output / Analog Input	MCU Port A Bit 2 / KBI1 Input Bit 2 / IIC bus data / ADC Analog Channel 2	
26	PTA1/KBI1P1/ TPM2CH0/ADP1/ ACMP1- ³	Digital Input/Output / Analog Input	MCU Port A Bit 1 / KBI1 Input Bit 1 / TPM2 Channel 0 / ADC Analog Channel 1 / ACMP1 Analog Input Minus	
27	PTA0/KBI1P0/ TPM1CH0/ADP0/ ACMP1+ ³	Digital Input/Output / Analog Input	MCU Port A Bit 0 / KBI1 Input Bit 0 / TPM1 Channel 0 / ADC Analog Channel 0 / ACMP1 Analog Input Plus	
28	PTC7/TXD2/ ACMP2-	Digital Input/Output / Analog Input	MCU Port C Bit 7 / SCI2 TXD / ACMP2 Analog Input Minus	
29	PTC6/RXD2/ ACMP2+	Digital Input/Output	MCU Port C Bit 6 / SCI2 RXD / ACMP2 Analog Input Plus	
30	NC		No Connect	
31	PTC5/TPM3CH5/ ACMP2O	Digital Input/Output	MCU Port C Bit 5 / TPM3 Channel 5 / ACMP2 Output	
32	PTC4/TPM3CH4	Digital Input/Output	MCU Port C Bit 5 / TPM3 Channel 5 / ACMP2 Output	
33	PTA5/IRQ/ TPM1CLK/RESETB	Digital Input/Output	MCU Port A Bit 5 / MCU IRQ / TPM1 Clock / MCU RESET	
34	PTA4/ACMP1O/ BKGD/MS	Digital Input/Output	MCU Port A Bit 4 / ACMP1 Output / Background Debug Port / Mode Select	
35	VBAT2	Power Input	Transceiver VDD	Connect to MC12311 VDD supply
36	GND	Power Input	Transceiver Ground	Connect to ground
37	RXTX (RF)	Digital Output	Transceiver Rx/Tx RF Switch Control Output; high when in TX	
38	GND_PA2 (RF)	Power Input	Transceiver RF Ground	Connect to ground
39	RFIO (RF)	RF Input/Output	Transceiver RF Input/Output	
40	GND_PA1 (RF)	Power Input	Transceiver RF Ground	Connect to ground
41	PA_BOOST	RF Output	Transceiver Optional High-Power PA Output	
42	VR_PA	Power Output	Transceiver regulated output voltage for VR_PA use.	
43	VBAT1 (RF)	Power Input	Transceiver VDD for RF circuitry	Connect to MC12311 VDD supply
44	VR_ANA	Power Output	Transceiver regulated output voltage for analog circuitry.	Decouple to ground with 100 nF capacitor

Table 1. Pin Function Description (continued)

Pin #	Pin Name	Type	Description	Functionality
45	VR_DIG	Power Output	Transceiver regulated output voltage for digital circuitry.	Decouple to ground with 100 nF capacitor
46	XTA	Xtal Osc	Transceiver crystal reference oscillator	Connect to 32 MHz crystal and load capacitor
47	XTB	Xtal Osc	Transceiver crystal reference oscillator	Connect to 32 MHz crystal and load capacitor
48	RESET	Digital Input	Transceiver hardware reset input	Typically driven from MCU GPIO
49	DIO0/PTD1/KBI2P1	Digital Input/Output	Transceiver GPIO Bit 0 / MCU Port D Bit 1 / MCU KBI2 Bit 1	MCU IO and Transceiver IO connected onboard MC12311
50	DIO1/PTD0/KBI2P0	Digital Input/Output	Transceiver GPIO Bit 1 / MCU Port D Bit 0 / MCU KBI2 Bit 0	MCU IO and Transceiver IO connected onboard MC12311
51	DIO2	Digital Input/Output	Transceiver GPIO Bit 2	
52	DIO3	Digital Input/Output	Transceiver GPIO Bit 3	
53	DIO4	Digital Input/Output	Transceiver GPIO Bit 4	
54	DIO5/CLKOUT	Digital Input/Output	Transceiver GPIO Bit 5 / ClkOut	Commonly programmed as ClkOut to supply MCU clock; connect to Pin 5
55	VDD1	Power Input	MCU VDD supply	Connect to MC12311 VDD supply
56	VDDAD	Power Input	MCU ADC VDD	Connect to MC12311 VDD supply
57	SPSCK ²	Digital Input/Output	SPI Port Clock driven from MCU Port E Bit 0	<ul style="list-style-type: none"> MCU IO and Transceiver IO connected onboard MC12311 MCU IO must be configured for this connection
58	MOSI ²	Digital Input/Output	SPI Port MOSI signal connected to MCU Port E Bit 1	<ul style="list-style-type: none"> MCU IO and Transceiver IO connected onboard MC12311 MCU IO must be configured for this connection
59	NSS ²	Digital Input/Output	SPI Port \overline{SS} signal connected to MCU Port E Bit 3	<ul style="list-style-type: none"> MCU IO and Transceiver IO connected onboard MC12311 MCU IO must be configured for this connection
60	MISO ²	Digital Input/Output	SPI Port MISO signal connected to MCU Port E Bit 2	<ul style="list-style-type: none"> MCU IO and Transceiver IO connected onboard MC12311 MCU IO must be configured for this connection
FLAG	VSS	Power input	External package flag. Common VSS	Connect to ground.

¹ IIC pins, SCL and SDA can be repositioned using the IICPS bit in SOPT2; default locations are PTA3 and PTA2.

² The SPI Port pin selection must be configured by software by writing the SPIPS Bit in Register SOPT2

³ If ADC and ACMP1 are both enabled, both modules have access to the pin.

5.2 Internal Functional Interconnects

The MCU provides control to the transceiver through the SPI Port and receives status from the transceiver from the DIOx pins. Certain interconnects between the devices are routed onboard the SiP. In addition, the signals are brought out to external pads.

Table 2. MC12311 Internal Functional Interconnects

Pin #	MCU Signal	Transceiver Signal	Description
49	PTD1/KBI2P1	DIO0	Transceiver DIO0 can be programmed to provide status to the MCU
50	PTD0/KBI2P0	DIO1	Transceiver DIO1 can be programmed to provide status to the MCU
57	PTE0/SPSCK	SCK	MCU SPI connection must be initiated, not default
58	PTE1/MOSI	MOSI	MCU SPI connection must be initiated, not default
59	PTE3/SS	NSS	MCU SPI connection must be initiated, not default
60	PTE2/MISO	MISO	MCU SPI connection must be initiated, not default

NOTE

- As shown in [Table 2](#), the MCU SPI Port pin selection must be configured by software by writing the SPIPS bit in Register SOPT2
- The transceiver DIO pins must be programmed to provide desired status

5.3 External Functional Interconnects

In addition to the onboard device interconnection, other external connections between the MCU and the transceiver are common:

1. Freescale recommends programming the transceiver DIO5 signal as ClkOut - for lowest system cost, a single crystal configuration can be used where ClkOut can be used to supply the MCU clock by connection to EXTAL Pin 5. With a 32 MHz transceiver reference oscillator crystal, ClkOut can be programmed for frequencies of 32 MHz, 16 MHz, 8 MHz, 4 MHz, 2 MHz, and 1 MHz.
2. Freesacle recommends driving/controlling the transceiver reset from an MCU GPIO - This allows over-riding control of the transceiver from the system application.
3. The other DIO2-DIO4 status and RXTX signals can prove useful for monitoring the transceiver operation - the DIO4-DIO2 signals must be programmed to provide operational status. All signals must be connected externally to appropriate MCU GPIO for this function.

6 System and Power Management

The MC12311 consists of an independent transceiver and MCU. The MCU controls the transceiver through programming of the SPI Port, and sets its operational mode through this control channel. Total current draw for the MC12311 is dependent on the operation mode of both devices.

6.1 Modes of Operation

The MCU is the host controller and has the following primary modes of operation:

- Stop2 - provides lowest standby power consumption and maintains the contents of RAM and the current state of all of the I/O pins, but the main oscillator and most other digital circuitry are off. Wake-up is treated as a system recovery from reset.
- Stop3 - provides very low standby power consumption and maintains the contents of RAM, registers, and the current state of all of the I/O pins, but the main oscillator can be enabled or not. Wake-up is treated as an interrupt request, and this provides faster recovery time
- Wait - entered by executing a WAIT command, the CPU enters a low power state. This state can be used to save power over a normal RUN condition, but is not a true low power state such as Stop2 or Stop3
- Run - normal run condition for the CPU. Current draw is very dependent on the CPU clock frequency. Additional current can be saved but running at a lower clock rate if the software performance.

The transceiver has the following modes of operation:

- Sleep - provides lowest power consumption and is the full power down state
- Idle - provides very low standby power consumption and has the main voltage regulator and the RC oscillator enabled
- Standby - similar to Idle with low standby power consumption but has the main voltage regulator and the crystal oscillator enabled
- FS (Frequency synthesizer) - the frequency synthesizer is alive to shorten startup time to transmit or receive states
- Transmit - transmitter is active
- Receive - receiver is active

6.2 Power Management

The MC12311 power management is controlled through programming of the modes of operation. Different modes allow for different levels of power-down. Additional features include:

- Transceiver Sleep with MCU Stop2 is the lowest power state
- The transceiver mode is independent of the MCU
- The transceiver uses/powers-up the transmitter or receiver only as required
- MCU peripheral control clock gating can be disabled on a module-by-module basis to provide lowest power
- RTC can be used as wake-up timer
- Wake-up available through KBI asynchronous interrupts and UART activity
- Wake-up available with RTC

6.3 System Protection

The MC12311 provides several vehicles to maintain security or a high level of system robustness:

- Watchdog computer operating properly (COP) reset with option to run from dedicated 1 kHz internal clock source or bus clock
- Low-voltage detection with reset or interrupt; selectable trip points
- Illegal opcode detection with reset
- Illegal address detection with reset
- Flash block protection

7 Development Environment

Development support for the HCS08 on the MC12311 includes the background debug controller (BDC) and the on-chip debug module (DBG). The BDC provides a single-wire debug interface to the MCU that provides a convenient interface for programming the on-chip FLASH and other storage. The BDC is also the primary debug interface for development and allows non-intrusive access to memory data and traditional debug features such as CPU register modify, breakpoints, and single instruction trace commands.

Address and data bus signals are not available on external pins. Debug is done through commands fed into the MCU via the single-wire background debug interface. The debug module provides a means to selectively trigger and capture bus information so an external development system can reconstruct what happened inside the MCU on a cycle-by-cycle basis without having external access to the address and data signals. Features include:

- Single-wire background debug interface
- Breakpoint capability to allow single breakpoint setting during in-circuit debugging (plus two more breakpoints)
- On-chip in-circuit emulator (ICE) debug module containing two comparators and nine trigger modes

8 System Electrical Specification

This section details maximum ratings for the 60 pin LGA package and recommended operating conditions, DC characteristics, and AC characteristics for the modem, and the MCU.

8.1 SiP LGA Package Maximum Ratings

Absolute maximum ratings are stress ratings only, and functional operation at the maximum rating is not guaranteed. Stress beyond the limits specified in [Table 3](#) may affect device reliability or cause permanent damage to the device. For functional operating conditions, refer to the remaining tables in this section.

This device contains circuitry protecting against damage due to high static voltage or electrical fields; however, it is advised that normal precautions be taken to avoid application of any voltages higher than maximum-rated voltages to this high-impedance circuit. Reliability of operation is enhanced if unused

inputs are tied to an appropriate logic voltage level (for instance, either V_{SS} or V_{DD}) or the programmable pull-up resistor associated with the pin is enabled.

Table 3 shows the maximum ratings for the 60 Pin LGA package.

Table 3. LGA Package Maximum Ratings

Rating	Symbol	Value	Unit
Maximum Junction Temperature	T_J	95	$^{\circ}\text{C}$
Storage Temperature Range	T_{stg}	-55 to 115	$^{\circ}\text{C}$
Power Supply Voltage	$V_{\text{BATT}}, V_{\text{DDINT}}$	-0.3 to 3.8	Vdc
Digital Input Voltage	V_{in}	-0.3 to ($V_{\text{DDINT}} + 0.3$)	
RF Input Power	P_{max}	6	dBm

Note: Maximum Ratings are those values beyond which damage to the device may occur. Functional operation should be restricted to the limits in the Electrical Characteristics or Recommended Operating Conditions tables.

Note: Meets Human Body Model (HBM) = 2 kV. RF input/output pins have no ESD protection.

8.2 ESD Protection and Latch-Up Immunity

Although damage from electrostatic discharge (ESD) is much less common on these devices than on early CMOS circuits, normal handling precautions should be used to avoid exposure to static discharge. Qualification tests are performed to ensure that these devices can withstand exposure to reasonable levels of static without suffering any permanent damage.

All ESD testing is in conformity with the JESD22 Stress Test Qualification for Commercial Grade Integrated Circuits. During the device qualification ESD stresses were performed for the human body model (HBM), the machine model (MM) and the charge device model (CDM).

All latchup testing is in conformity with the JESD78 IC Latch-Up Test.

A device is defined as a failure if after exposure to ESD pulses the device no longer meets the device specification.

Table 4. ESD and Latch-up Test Conditions

Model	Description	Symbol	Value	Unit
Human Body	Series resistance	R1	1500	Ω
	Storage capacitance	C	100	pF
	Number of pulses per pin ¹	—	1	
Machine	Series resistance	R1	0	Ω
	Storage capacitance	C	200	pF
	Number of pulses per pin ¹	—	1	
Latch-up	Minimum input voltage limit		-1.8	V
	Maximum input voltage limit		4.32	V

¹ This number represents a minimum number for both positive pulse(s) and negative pulse(s)

Table 5. ESD and Latch-Up Protection Characteristics

No.	Rating ¹	Symbol	Min	Max	Unit
1	Human body model (HBM)	V_{HBM}	± 2000	—	V
2	Machine model (MM)	V_{MM}	± 200	—	V
3	Charge device model (CDM)	V_{CDM}	± 750	—	V
4	Latch-up current at $T_A = 85^\circ\text{C}$	I_{LAT}	± 100	—	mA

¹ Parameter is achieved by design characterization on a small sample size from typical devices under typical conditions unless otherwise noted.

8.3 Transceiver Electrical Characteristics

The tables below give the electrical specifications of the transceiver under the following conditions: Supply voltage $V_{BAT1} = V_{BAT2} = V_{DD} = 3.3\text{ V}$, temperature = 25°C , $FXOSC = 32\text{ MHz}$, $FRF = 915\text{ MHz}$, $P_{out} = +13\text{ dBm}$, 2-level FSK modulation without pre-filtering, $F_{DA} = 5\text{ kHz}$, Bit Rate = 4.8 kb/s and terminated in a matched 50 Ohm impedance, unless otherwise specified.

NOTE

Unless otherwise specified, the performances in the other frequency bands are similar or better.

8.3.1 Transceiver Recommended Operating Conditions

Table 6. Recommended Operating Conditions

Characteristic	Symbol	Min	Typ	Max	Unit
Power Supply Voltage (V_{BATT})		1.8		3.6	Vdc
Operating Temperature Range	T_A	-40	25	85	$^\circ\text{C}$
Logic Input Voltage Low	V_{IL}	0	-	20% V_{BATT}	V
Logic Input Voltage High	V_{IH}	80% V_{BATT}	-	V_{BATT}	V
Logic Output Voltage Low ($I_{max} = -1\text{ mA}$)	V_{OL}	0	-	10% V_{BATT}	V
Logic Output Voltage High ($I_{max} = 1\text{ mA}$)	V_{OH}	90% V_{BATT}	-	V_{BATT}	V
Load capacitance on digital ports	C_L			25	pF
SPI Clock Rate	f_{SPI}	-	-	8.0	MHz
RF Input Power	P_{max}	-	-	0	dBm
Crystal Reference Oscillator Frequency	f_{ref}	32 MHz Only			

8.3.2 Transceiver Power Consumption

Table 7. Power Supply Current

Characteristic	Conditions	Symbol	Min	Typ	Max	Unit
Supply current in Sleep mode		IDDSL	-	0.1	1	μA
Supply current in Idle mode	RC oscillator enabled	IDDIDLE	-	1.2	-	μA
Supply current in Standby mode	Crystal oscillator enabled	IDDST	-	1.25	1.5	mA
Supply current in Synthesizer mode		IDDFS	-	9	-	mA
Supply current in Receive mode		IDDR	-	16	-	mA
Supply current in Transmit mode with appropriate matching, stable across VDD range	RFOP = +17 dBm, on PA_BOOST	IDDT	-	95	-	mA
	RFOP = +13 dBm, on RFIO pin		-	45	-	mA
	RFOP = +10 dBm, on RFIO pin		-	33	-	mA
	RFOP = 0 dBm, on RFIO pin		-	20	-	mA
	RFOP = -1 dBm, on RFIO pin		-	16	-	mA

8.3.3 Transceiver Frequency Synthesis

Table 8. Frequency Synthesizer Specification

Characteristic	Conditions	Symbol	Min	Typ	Max	Unit
Synthesizer Frequency Range	Programmable	FR	290	-	340	MHz
			424	-	510	MHz
			862	-	1020	MHz
Crystal oscillator frequency		FXOSC	-	32	-	MHz
Crystal oscillator wake-up time		TS_OSC	-	250	500	μs
Frequency synthesizer wake-up time to PLLock signal	From Standby mode	TS_FS	-	80	150	μs
Frequency synthesizer hop time at most 10 kHz away from the target	200 kHz step	TS_HOP	-	20	-	μs
	1 MHz step		-	20	-	μs
	5 MHz step		-	50	-	μs
	7 MHz step		-	50	-	μs
	12 MHz step		-	80	-	μs
	20 MHz step		-	80	-	μs
25 MHz step	-	80	-	μs		
Frequency synthesizer step	$FSTEP = FXOSC/2^{19}$	FSTEP	-	61.0	-	Hz
RC Oscillator frequency	After calibration	FRC	-	62.5	-	kHz
Bit rate, FSK	Programmable	BRF	1.2	-	300	kbps
Bit rate, OOK	Programmable	BRO	1.2	-	32.768	kbps
Frequency deviation, FSK	Programmable $FDA + BRF/2 \leq 500$ kHz	FDA	0.6	-	300	kHz

8.3.4 Receiver

All receiver tests are performed with RxBw = 10 kHz (Single Side Bandwidth) as programmed in RegRxBw, receiving a PN15 sequence with a BER of 0.1% (Bit Synchronizer is enabled), unless otherwise specified. The LNA impedance is set to 200 Ohms, by setting bit LnaZin in RegLna to 1. Blocking tests are performed with an unmodulated interferer. The wanted signal power for the Blocking Immunity, ACR, IIP2, IIP3 and AMR tests is set 3 dB above the nominal sensitivity level.

Table 9. Receiver Specification

Characteristic	Conditions	Symbol	Min	Typ	Max	Unit
FSK sensitivity, highest LNA gain	FDA = 5 kHz, BR = 1.2 kb/s	RFS_F	-	-118	-	dBm
	FDA = 5 kHz, BR = 4.8 kb/s		-	-114	-	dBm
	FDA = 40 kHz, BR = 38.4 kb/s		-	-105	-	dBm
	FDA = 5 kHz, BR = 1.2 kb/s ¹		-	-120	-	dBm
OOK sensitivity, highest LNA gain	BR = 4.8 kb/s	RFS_O	-	-112	-109	dBm
Co-Channel Rejection		CCR	-13	-10	-	dB
Adjacent Channel Rejection	Offset = +/- 25 kHz Offset = +/- 50 kHz	ACR	-	42	-	dB
			37	42	-	dB
Blocking Immunity	Offset = +/- 1 MHz Offset = +/- 2 MHz Offset = +/- 10 MHz	BI	-	-45	-	dBm
			-	-40	-	dBm
			-	-32	-	dBm
Blocking Immunity Wanted signal at sensitivity +16dB	Offset = +/- 1 MHz Offset = +/- 2 MHz Offset = +/- 10 MHz		-	-36	-	dBm
			-	-33	-	dBm
			-	-25	-	dBm
AM Rejection , AM modulated interferer with 100% modulation depth, fm = 1 kHz, square	Offset = +/- 1 MHz Offset = +/- 2 MHz Offset = +/- 10 MHz	AMR	-	-45	-	dBm
			-	-40	-	dBm
			-	-32	-	dBm
2nd order Input Intercept Point Unwanted tones are 20 MHz above the LO	Lowest LNA gain Highest LNA gain	IIP2	-	+75	-	dBm
			-	+35	-	dBm
3rd order Input Intercept point Unwanted tones are 1MHz and 1.995 MHz above the LO	Lowest LNA gain Highest LNA gain	IIP3	-	+20	-	dBm
			-23	-18	-	dBm
Single Side channel filter BW	Programmable	BW_SSB	2.6	-	500	kHz
Image rejection in OOK mode	Wanted signal level = -106 dBm	IMR_ OOK	27	30	-	dB
Receiver wake-up time, from PLL locked state to RxReady	RxBw = 10 kHz, BR = 4.8 kb/s	TS_RE	-	1.7	-	ms
	RxBw = 200 kHz, BR = 100 kb/s		-	96	-	µs
Receiver wake-up time, from PLL locked state, AGC enabled	RxBw= 10 kHz, BR = 4.8 kb/s	TS_RE_ AGC	-	3.0	-	ms
	RxBw = 200 kHz, BR = 100 kb/s		-	163	-	µs
Receiver wake-up time, from PLL lock state, AGC and AFC enabled	RxBw= 10 kHz, BR = 4.8 kb/s RxBw = 200 kHz, BR = 100 kb/s	TS_RE_ AGC&AFC	-	4.8	-	ms
			-	265	-	µs
FEI sampling time	Receiver is ready	TS_FEI	-	4.T _{bit}	-	-
AFC Response Time	Receiver is ready	TS_AFC	-	4.T _{bit}	-	-

Table 9. Receiver Specification

Characteristic	Conditions	Symbol	Min	Typ	Max	Unit
RSSI Response Time	Receiver is ready	TS_RSSI	-	2.T _{bit}	-	-
RSSI Dynamic Range	AGC enabled	DR_RSSI	-	-115	-	dBm
	Min		-	0	-	dBm
	Max		-		-	dBm

¹ Set SensitivityBoost in RegTestLna to 0x2D to reduce the noise floor in the receiver

8.3.5 Transmitter

Table 10. Transmitter Specification

Characteristic	Conditions	Symbol	Min	Typ	Max	Unit
RF output power in 50 ohms On RFIO pin	Programmable with 1dB steps Max Min	RF_OP	-	+13	-	dBm
			-	-18	-	dBm
Max RF output power, on PA_BOOST pin	With external match to 50 ohms	RF_OPH	-	+17	-	dBm
RF output power stability	From VDD=1.8V to 3.6V	ΔRF_OP	-	+/-0.3	-	dB
Transmitter Phase Noise	50 kHz Offset from carrier 868 / 915 MHz bands 434 / 315 MHz bands	PHN	-	-95	-	dBc/Hz
			-	-99	-	dBc/Hz
Transmitter adjacent channel power (measured at 25 kHz offset)	BT=0.5 . Measurement conditions as defined by EN 300 220-1 V2.1.1	ACP	-	-	-37	dBm
Transmitter wake up time, to the first rising edge of DCLK	Frequency Synthesizer enabled, PaRamp = 10 μs, BR = 4.8 kb/s.	TS_TR	-	120	-	μs

8.4 MCU Electrical Characteristics

The following sections describe the electrical characteristics of the MC12311 MCU.

8.4.1 MCU DC Characteristics

This section includes information about power supply requirements and I/O pin characteristics.

Table 11. DC Characteristics

Num	C	Characteristic	Symbol	Condition	Min	Typ ¹	Max	Unit
1		Operating Voltage			1.8 ²		3.6	V
2	C	Output high voltage	V _{OH}	All I/O pins, low-drive strength	1.8 V, I _{Load} = -2 mA	V _{DD} - 0.5	—	V
	P			All I/O pins, high-drive strength	2.7 V, I _{Load} = -10 mA	V _{DD} - 0.5	—	
	T				2.3 V, I _{Load} = -6 mA	V _{DD} - 0.5	—	
	C				1.8V, I _{Load} = -3 mA	V _{DD} - 0.5	—	

Table 11. DC Characteristics (continued)

Num	C	Characteristic	Symbol	Condition	Min	Typ ¹	Max	Unit
3	D	Output high current Max total I_{OH} for all ports	I_{OHT}		—	—	100	mA
4	C	Output low voltage All I/O pins, low-drive strength All I/O pins, high-drive strength	V_{OL}	1.8 V, $I_{Load} = 2$ mA	—	—	0.5	V
	P			2.7 V, $I_{Load} = 10$ mA	—	—	0.5	
	T			2.3 V, $I_{Load} = 6$ mA	—	—	0.5	
	C			1.8 V, $I_{Load} = 3$ mA	—	—	0.5	
5	D	Output low current Max total I_{OL} for all ports	I_{OLT}		—	—	100	mA
6	P	Input high voltage all digital inputs	V_{IH}	$V_{DD} > 2.7$ V	$0.70 \times V_{DD}$	—	—	V
	C			$V_{DD} > 1.8$ V	$0.85 \times V_{DD}$	—	—	
7	P	Input low voltage all digital inputs	V_{IL}	$V_{DD} > 2.7$ V	—	—	$0.35 \times V_{DD}$	V
	C			$V_{DD} > 1.8$ V	—	—	$0.30 \times V_{DD}$	
8	C	Input hysteresis all digital inputs	V_{hys}		$0.06 \times V_{DD}$	—	—	mV
9	P	Input leakage current all input only pins (Per pin)	$ I_{In} $	$V_{In} = V_{DD}$ or V_{SS}	—	—	1	μ A
10	P	Hi-Z (off-state) leakage current all input/output (per pin)	$ I_{OZ} $	$V_{In} = V_{DD}$ or V_{SS}	—	—	1	μ A
11	P	Total leakage combined for all inputs and Hi-Z pins All input only and I/O	$ I_{OZTOT} $	$V_{In} = V_{DD}$ or V_{SS}	—	—	2	μ A
12	P	Pull-up resistors all digital inputs, when enabled	R_{PU}		17.5	—	52.5	k Ω
13	D	DC injection current ^{3, 4, 5} Single pin limit Total MCU limit, includes sum of all stressed pins	I_{IC}	$V_{IN} < V_{SS}$, $V_{IN} > V_{DD}$	-0.2	—	0.2	mA
					-5	—	5	mA
14	C	Input Capacitance, all pins	C_{In}		—	—	8	pF
15	C	RAM retention voltage	V_{RAM}		—	0.6	1.0	V
16	C	POR re-arm voltage ⁶	V_{POR}		0.9	1.4	1.79	V

Table 11. DC Characteristics (continued)

Num	C	Characteristic	Symbol	Condition	Min	Typ ¹	Max	Unit
17	D	POR re-arm time	t_{POR}		10	—	—	μ s
18	P	Low-voltage detection threshold — high range ⁷	V_{LVDH} ⁸	V_{DD} falling V_{DD} rising	2.11 2.16	2.16 2.21	2.22 2.27	V
19	P	Low-voltage detection threshold — low range ⁷	V_{LVDL}	V_{DD} falling V_{DD} rising	1.80 1.86	1.82 1.90	1.91 1.99	V
20	P	Low-voltage warning threshold — high range ⁷	V_{LVWH}	V_{DD} falling V_{DD} rising	2.36 2.36	2.46 2.46	2.56 2.56	V
21	P	Low-voltage warning threshold — low range ⁷	V_{LVWL}	V_{DD} falling V_{DD} rising	2.11 2.16	2.16 2.21	2.22 2.27	V
22	C	Low-voltage inhibit reset/recover hysteresis ⁷	V_{hys}		—	50	—	mV
23	P	Bandgap Voltage Reference ⁹	V_{BG}		1.15	1.17	1.18	V

¹ Typical values are measured at 25°C. Characterized, not tested

² As the supply voltage rises, the LVD circuit will hold the MCU in reset until the supply has risen above V_{LVDL} .

³ All functional non-supply pins are internally clamped to V_{SS} and V_{DD} .

⁴ Input must be current limited to the value specified. To determine the value of the required current-limiting resistor, calculate resistance values for positive and negative clamp voltages, then use the larger of the two values.

⁵ Power supply must maintain regulation within operating V_{DD} range during instantaneous and operating maximum current conditions. If positive injection current ($V_{in} > V_{DD}$) is greater than I_{DD} , the injection current may flow out of V_{DD} and could result in external power supply going out of regulation. Ensure external V_{DD} load will shunt current greater than maximum injection current. This will be the greatest risk when the MCU is not consuming power. Examples are: if no system clock is present, or if clock rate is very low (which would reduce overall power consumption).

⁶ Maximum is highest voltage that POR is guaranteed.

⁷ Low voltage detection and warning limits measured at 1 MHz bus frequency.

⁸ Run at 1 MHz bus frequency

⁹ Factory trimmed at $V_{DD} = 3.0$ V, Temp = 25°C

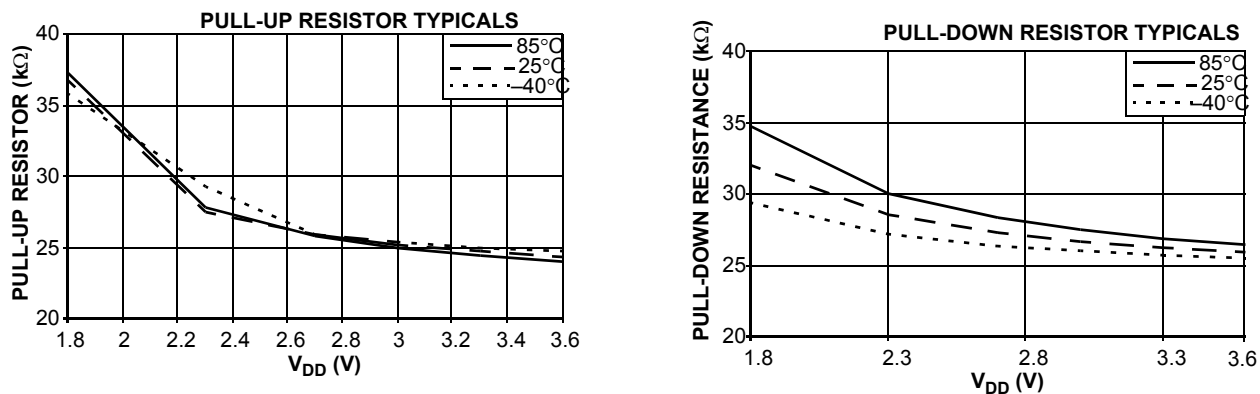

Figure 6. Pull-up and Pull-down Typical Resistor Values

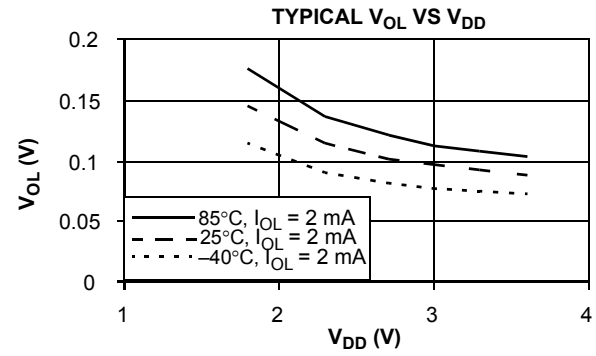
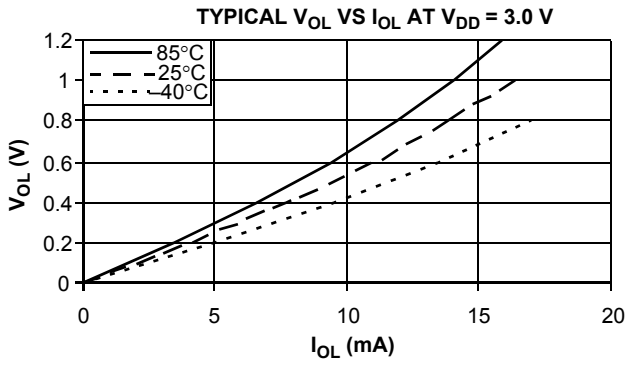

Figure 7. Typical Low-Side Driver (Sink) Characteristics — Low Drive (PTxDSn = 0)

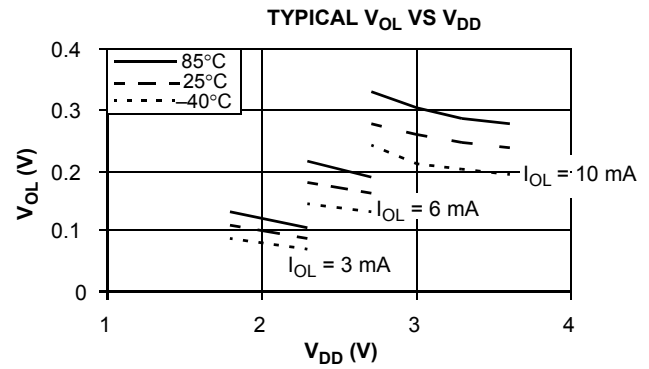
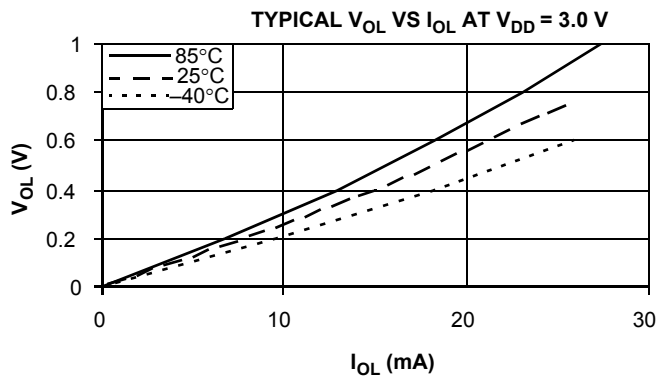

Figure 8. Typical Low-Side Driver (Sink) Characteristics — High Drive (PTxDSn = 1)

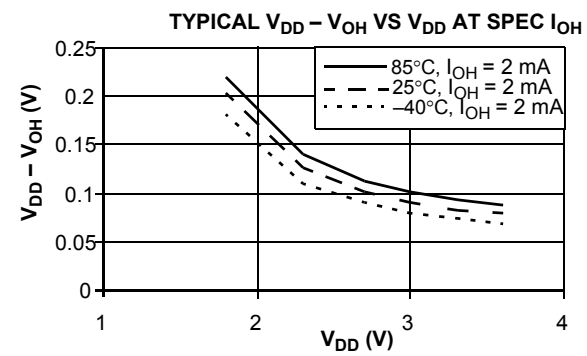
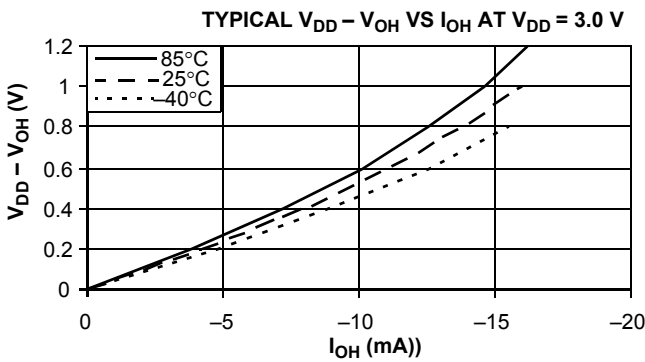

Figure 9. Typical High-Side (Source) Characteristics — Low Drive (PTxDSn = 0)

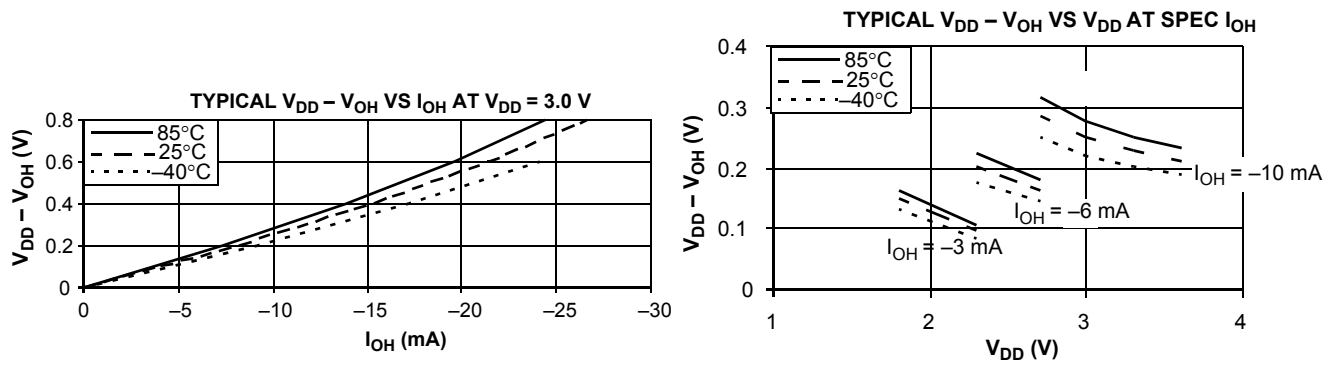

Figure 10. Typical High-Side (Source) Characteristics — High Drive (PTxDSn = 1)

8.4.2 MCU Supply Current Characteristics

This section includes information about power supply current in various operating modes.

Table 12. Supply Current Characteristics

Num	C	Parameter	Symbol	Bus Freq	V _{DD} (V)	Typ ¹	Max	Unit	Temp (°C)	
1	P	Run supply current FEI mode, all modules on	R _{I_{DD}}	25.165 MHz	3	13	184	mA	-40 to 25	
	P					14	15		85	
	T					20 MHz	13.75		—	-40 to 85
	T					8 MHz	5.59		—	
	T					1 MHz	1.03		—	
2	C	Run supply current FEI mode, all modules off	R _{I_{DD}}	25.165 MHz	3	11.5	12.3	mA	-40 to 85	
	T					20 MHz	9.5			—
	T					8 MHz	4.6			—
	T					1 MHz	1.0			—
3	T	Run supply current LPS=0, all modules off	R _{I_{DD}}	16 kHz FBILP	3	152	—	μA	-40 to 85	
	T					16 kHz FBELP	115			—
4	T	Run supply current LPS=1, all modules off, running from Flash	R _{I_{DD}}	16 kHz FBELP	3	21.9	—	μA	0 to 70	
	T	Run supply current LPS=1, all modules off, running from RAM				7.3	—		-40 to 85	
5	C	Wait mode supply current FEI mode, all modules off	W _{I_{DD}}	25.165 MHz	3	5.74	6	mA	-40 to 85	
	T					20 MHz	4.57			—
	T					8 MHz	2			—
	T					1 MHz	0.73			—

Table 12. Supply Current Characteristics (continued)

Num	C	Parameter	Symbol	Bus Freq	V _{DD} (V)	Typ ¹	Max	Unit	Temp (°C)
6	P	Stop2 mode supply current	S2I _{DD}	n/a	3	0.35	0.65	μA	-40 to 25
	C					0.8	1.0		70
	P					2.0	4.5		85
	C				2	0.25	0.5		-40 to 25
	C					0.65	0.85		70
	C					1.5	3.5		85
7	P	Stop3 mode supply current No clocks active	S3I _{DD}	n/a	3	0.45	1.0	μA	-40 to 25
	C					1.5	2.3		70
	P					4	8		85
	C				2	0.35	0.7		-40 to 25
	C					1	2		70
	C					3.5	6.0		85
8	T	Low power mode adders:	EREFSTEN=1	32 kHz	3	500		nA	-40 to 85
9	T		IREFSTEN=1	32 kHz		70		μA	
10	T		TPM PWM	100 Hz		12		nA	
11	T		SCI, SPI, or IIC	300 bps		15		μA	
12	T		RTC using LPO	1 kHz		200		μA	
13	T		RTC using IC SERCLK	32 kHz		1		μA	
14	T		LVD	n/a		100		μA	
15	T		ACMP	n/a		20		μA	

¹ Data in Typical column was characterized at 3.0 V, 25°C or is typical recommended value.

Table 13. Stop Mode Adders

Num	C	Parameter	Condition	Temperature (°C)				Units
				-40	25	70	85	
1	T	LPO		50	75	100	150	nA
2	T	EREFSTEN	RANGE = HGO = 0	1000	1000	1100	1500	nA
3	T	IREFSTEN ¹		63	70	77	81	uA
4	T	RTC	does not include clock source current	50	75	100	150	nA
5	T	LVD ¹	LVDSE = 1	90	100	110	115	uA
6	T	ACMP ¹	not using the bandgap (BGBE = 0)	18	20	22	23	uA
7	T	ADC ¹	ADLPC = ADLSMP = 1 not using the bandgap (BGBE = 0)	95	106	114	120	uA

¹ Not available in stop2 mode.

8.4.3 External Oscillator (XOSCVLP) Characteristics

Reference [Figure 11](#) and [Figure 12](#) for crystal or resonator circuits.

Table 14. XOSC and ICS Specifications (Temperature Range = -40 to 85°C Ambient)

Num	C	Characteristic	Symbol	Min	Typ ¹	Max	Unit
1	C	Oscillator crystal or resonator (EREFS = 1, ERCLKEN = 1)					
		Low range (RANGE = 0)	f_{lo}	32	—	38.4	kHz
		High range (RANGE = 1), high gain (HGO = 1)	f_{hi}	1	—	16	MHz
		High range (RANGE = 1), low power (HGO = 0)	f_{hi}	1	—	8	MHz
2	D	Load capacitors Low range (RANGE=0), low power (HGO=0) Other oscillator settings	C_1, C_2	See Note ² See Note ³			
3	D	Feedback resistor	R_F	—	—	—	M Ω
		Low range, low power (RANGE=0, HGO=0) ²		—	10	—	
		Low range, High Gain (RANGE=0, HGO=1) High range (RANGE=1, HGO=X)		—	1	—	
4	D	Series resistor —	R_S	—	—	—	k Ω
		Low range, low power (RANGE = 0, HGO = 0) ²		—	0	—	
		Low range, high gain (RANGE = 0, HGO = 1)		—	100	—	
		High range, low power (RANGE = 1, HGO = 0)		—	0	0	
		High range, high gain (RANGE = 1, HGO = 1)		—	0	10	
		≥ 8 MHz	—	0	20		
		4 MHz	—	0	10		
		1 MHz	—	0	20		
5	C	Crystal start-up time ⁴	t_{CSTL}	—	200	—	ms
		Low range, low power		—	400	—	
		Low range, high power	t_{CSTH}	—	5	—	
		High range, low power		—	15	—	
High range, high power							
6	D	Square wave input clock frequency (EREFS = 0, ERCLKEN = 1)	f_{extal}	0.03125 0	— —	40.0 50.33	MHz MHz
		FEE or FBE mode					
		FBELP mode					

¹ Data in Typical column was characterized at 3.0 V, 25°C or is typical recommended value.

² Load capacitors (C_1, C_2), feedback resistor (R_F) and series resistor (R_S) are incorporated internally when RANGE=HGO=0.

³ See crystal or resonator manufacturer's recommendation.

⁴ Proper PC board layout procedures must be followed to achieve specifications.

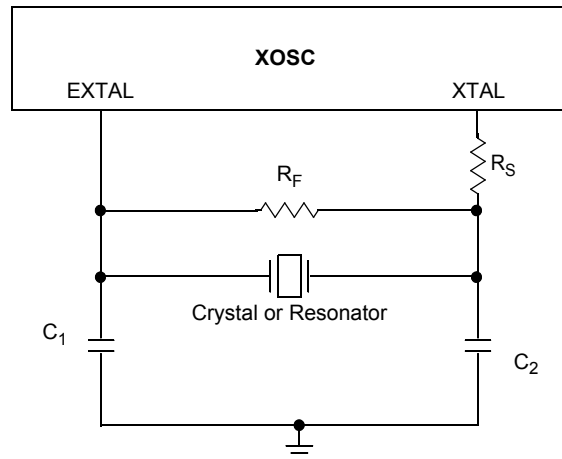

Figure 11. Typical Crystal or Resonator Circuit: High Range and Low Range/High Gain

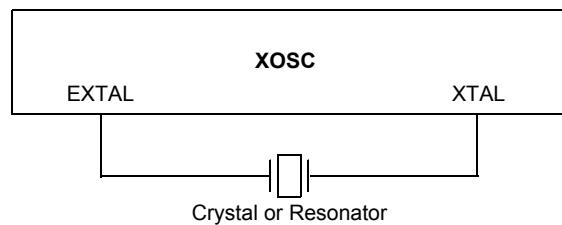

Figure 12. Typical Crystal or Resonator Circuit: Low Range/Low Gain

8.4.4 Internal Clock Source (ICS) Characteristics

Table 15. ICS Frequency Specifications (Temperature Range = -40 to 85°C Ambient)

Num	C	Characteristic	Symbol	Min	Typ ¹	Max	Unit	
1	P	Average internal reference frequency — factory trimmed at $V_{DD} = 3.6\text{ V}$ and temperature = 25°C	$f_{\text{int_ft}}$	—	32.768	—	kHz	
2	P	Internal reference frequency — user trimmed	$f_{\text{int_ut}}$	31.25	—	39.06	kHz	
3	T	Internal reference start-up time	t_{IRST}	—	5	10	μs	
4	P	DCO output frequency range — trimmed ²	$f_{\text{dco_u}}$	Low range (DRS=00)	16	—	20	MHz
	P			Mid range (DRS=01)	32	—	40	
	P			High range (DRS=10)	48	—	60	
5	P	DCO output frequency ² Reference = 32768 Hz and DMX32 = 1	$f_{\text{dco_DMX32}}$	Low range (DRS=00)	—	19.92	—	MHz
	P			Mid range (DRS=01)	—	39.85	—	
	P			High range (DRS=10)	—	59.77	—	
6	C	Resolution of trimmed DCO output frequency at fixed voltage and temperature (using FTRIM)	$\Delta f_{\text{dco_res_t}}$	—	± 0.1	± 0.2	$\%f_{\text{dco}}$	
7	C	Resolution of trimmed DCO output frequency at fixed voltage and temperature (not using FTRIM)	$\Delta f_{\text{dco_res_t}}$	—	± 0.2	± 0.4	$\%f_{\text{dco}}$	

Table 15. ICS Frequency Specifications (Temperature Range = –40 to 85°C Ambient) (continued)

Num	C	Characteristic	Symbol	Min	Typ ¹	Max	Unit
8	C	Total deviation of trimmed DCO output frequency over voltage and temperature	Δf_{dco_t}	—	+ 0.5 -1.0	± 2	% f_{dco}
9	C	Total deviation of trimmed DCO output frequency over fixed voltage and temperature range of 0°C to 70 °C	Δf_{dco_t}	—	± 0.5	± 1	% f_{dco}
10	C	FLL acquisition time ³	$t_{Acquire}$	—	—	1	ms
11	C	Long term jitter of DCO output clock (averaged over 2-ms interval) ⁴	C_{Jitter}	—	0.02	0.2	% f_{dco}

¹ Data in Typical column was characterized at 3.0 V, 25°C or is typical recommended value.

² The resulting bus clock frequency should not exceed the maximum specified bus clock frequency of the device.

³ This specification applies to any time the FLL reference source or reference divider is changed, trim value changed or changing from FLL disabled (FBELP, FBILP) to FLL enabled (FEI, FEE, FBE, FBI). If a crystal/resonator is being used as the reference, this specification assumes it is already running.

⁴ Jitter is the average deviation from the programmed frequency measured over the specified interval at maximum f_{Bus} . Measurements are made with the device powered by filtered supplies and clocked by a stable external clock signal. Noise injected into the FLL circuitry via V_{DD} and V_{SS} and variation in crystal oscillator frequency increase the C_{Jitter} percentage for a given interval.

8.4.5 MCU AC Characteristics

This section describes timing characteristics for each peripheral system.

8.4.5.1 Control Timing

Table 16. Control Timing

Num	C	Rating	Symbol	Min	Typ ¹	Max	Unit
1	D	Bus frequency ($t_{cyc} = 1/f_{Bus}$) $V_{DD} \geq 1.8V$ $V_{DD} > 2.1V$ $V_{DD} > 2.4V$	f_{Bus}	dc	— — —	10 20 25.165	MHz
2	D	Internal low power oscillator period	t_{LPO}	700	—	1300	μs
3	D	External reset pulse width ²	t_{extrst}	100	—	—	ns
4	D	Reset low drive	t_{rstdrv}	$34 \times t_{cyc}$	—	—	ns
5	D	BKGD/MS setup time after issuing background debug force reset to enter user or BDM modes	t_{MSSU}	500	—	—	ns
6	D	BKGD/MS hold time after issuing background debug force reset to enter user or BDM modes ³	t_{MSH}	100	—	—	μs
7	D	IRQ pulse width Asynchronous path ² Synchronous path ⁴	t_{ILIH}, t_{IHIL}	100 $1.5 \times t_{cyc}$	— —	— —	ns

Table 16. Control Timing (continued)

Num	C	Rating	Symbol	Min	Typ ¹	Max	Unit
8	D	Keyboard interrupt pulse width Asynchronous path ² Synchronous path ⁴	t_{LILH}, t_{IHIL}	100 $1.5 \times t_{cyc}$	— —	— —	ns
9	C	Port rise and fall time — Low output drive (PTxDS = 0) (load = 50 pF) ⁵ Slew rate control disabled (PTxSE = 0) Slew rate control enabled (PTxSE = 1)	t_{Rise}, t_{Fall}	— —	8 31	— —	ns
		Port rise and fall time — High output drive (PTxDS = 1) (load = 50 pF) Slew rate control disabled (PTxSE = 0) Slew rate control enabled (PTxSE = 1)	t_{Rise}, t_{Fall}	— —	7 24	— —	ns
10		Voltage regulator recovery time	t_{VRR}	—	4	—	μ s

¹ Typical values are based on characterization data at $V_{DD} = 3.0V$, $25^{\circ}C$ unless otherwise stated.

² This is the shortest pulse that is guaranteed to be recognized as a reset or interrupt pin request. Shorter pulses are not guaranteed to override reset requests from internal sources.

³ To enter BDM mode following a POR, BKGD/MS should be held low during the power-up and for a hold time of t_{MSH} after V_{DD} rises above V_{LVD} .

⁴ This is the minimum pulse width that is guaranteed to pass through the pin synchronization circuitry. Shorter pulses may or may not be recognized. In stop mode, the synchronizer is bypassed so shorter pulses can be recognized in that case.

⁵ Timing is shown with respect to 20% V_{DD} and 80% V_{DD} levels. Temperature range $-40^{\circ}C$ to $85^{\circ}C$.

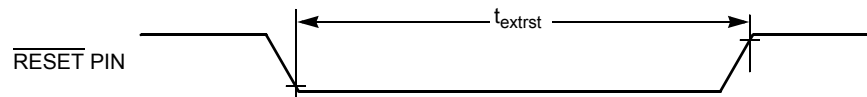

Figure 13. Reset Timing

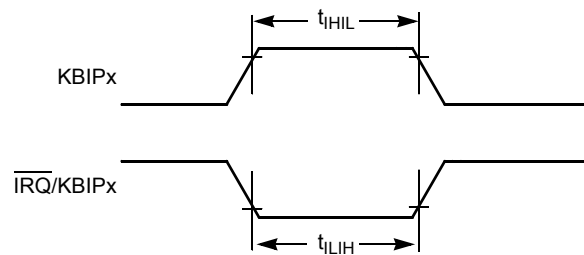

Figure 14. IRQ/KBIPx Timing

8.4.6 TPM Module Timing

Synchronizer circuits determine the shortest input pulses that can be recognized or the fastest clock that can be used as the optional external source to the timer counter. These synchronizers operate from the current bus rate clock.

Table 17. TPM Input Timing

No.	C	Function	Symbol	Min	Max	Unit
1	D	External clock frequency	f_{TCLK}	0	$f_{Bus}/4$	Hz
2	D	External clock period	t_{TCLK}	4	—	t_{cyc}
3	D	External clock high time	t_{clkh}	1.5	—	t_{cyc}
4	D	External clock low time	t_{clkl}	1.5	—	t_{cyc}
5	D	Input capture pulse width	t_{ICPW}	1.5	—	t_{cyc}

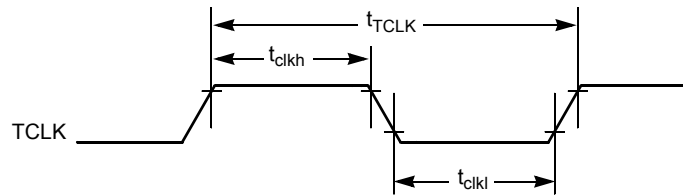

Figure 15. Timer External Clock

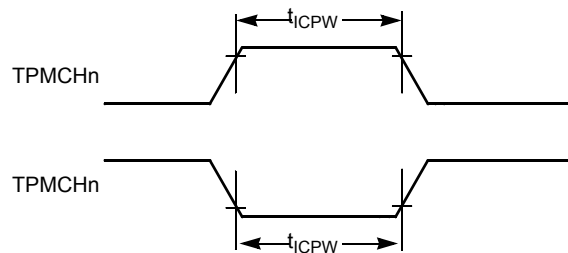

Figure 16. Timer Input Capture Pulse

8.4.7 ADC Characteristics

Table 18. 12-bit ADC Operating Conditions

C	Characteristic	Conditions	Symb	Min	Typ ¹	Max	Unit	Comment
D	Supply voltage	Absolute	V_{DDA}	1.8	—	3.6	V	
		Delta to V_{DD} ($V_{DD}-V_{DDA}$) ²	ΔV_{DDA}	-100	0	+100	mV	
D	Ground voltage	Delta to V_{SS} ($V_{SS}-V_{SSA}$) ²	ΔV_{SSA}	-100	0	+100	mV	
D	Ref Voltage High		V_{REFH}	1.8	V_{DDA}	V_{DDA}	V	
D	Ref Voltage Low		V_{REFL}	V_{SSA}	V_{SSA}	V_{SSA}	V	
D	Input Voltage		V_{ADIN}	V_{REFL}	—	V_{REFH}	V	
C	Input Capacitance		C_{ADIN}	—	4.5	5.5	pF	
C	Input Resistance		R_{ADIN}	—	5	7	k Ω	

Table 18. 12-bit ADC Operating Conditions (continued)

C	Characteristic	Conditions	Symb	Min	Typ ¹	Max	Unit	Comment
C	Analog Source Resistance	12 bit mode $f_{ADCK} > 4\text{MHz}$ $f_{ADCK} < 4\text{MHz}$	R_{AS}	—	—	2	k Ω	External to MCU
		10 bit mode $f_{ADCK} > 4\text{MHz}$ $f_{ADCK} < 4\text{MHz}$		—	—	5		
		8 bit mode (all valid f_{ADCK})		—	—	10		
D	ADC Conversion Clock Freq.	High Speed (ADLPC=0)	f_{ADCK}	0.4	—	8.0	MHz	
		Low Power (ADLPC=1)		0.4	—	4.0		

¹ Typical values assume $V_{DDA} = 3.0\text{V}$, Temp = 25°C, $f_{ADCK}=1.0\text{MHz}$ unless otherwise stated. Typical values are for reference only and are not tested in production.

² DC potential difference.

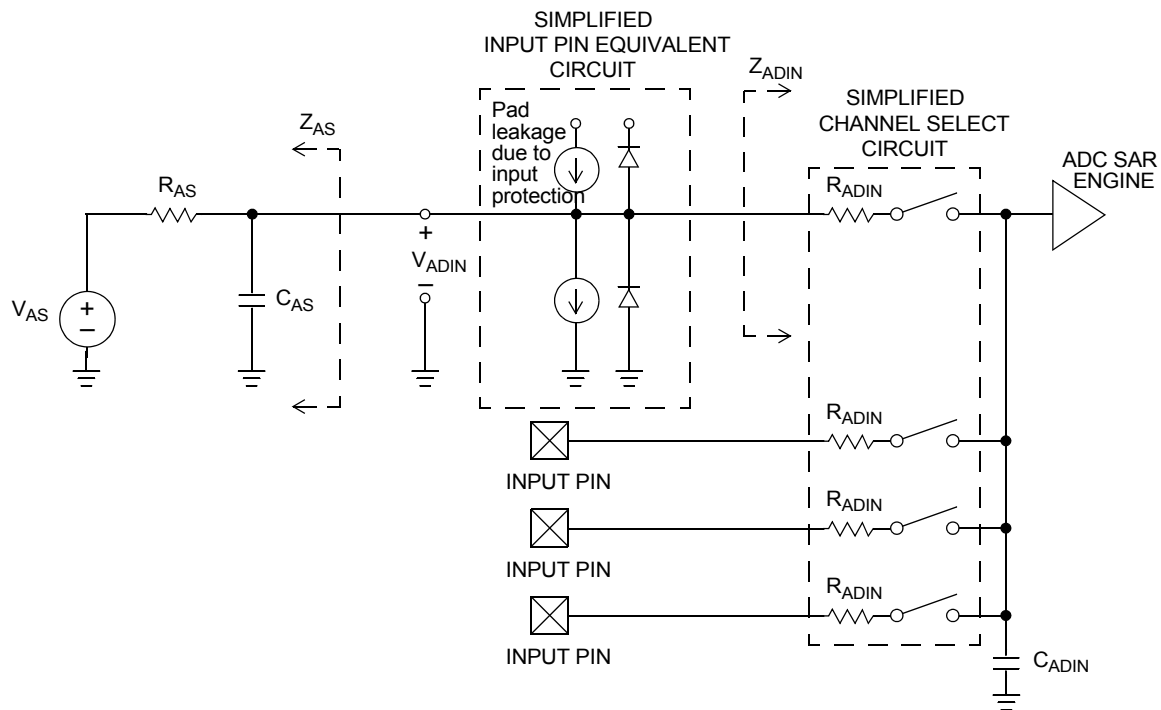

Figure 17. ADC Input Impedance Equivalency Diagram

Table 19. 12-bit ADC Characteristics ($V_{REFH} = V_{DDA_{SSA}}$, $V_{REFL} = V_{SSA}$)

Characteristic	Conditions	C	Symb	Min	Typ ¹	Max	Unit	Comment	
Supply Current ADLPC=1 ADLSMP=1 ADCO=1		T	I_{DDA}	—	120	—	μA		
Supply Current ADLPC=1 ADLSMP=0 ADCO=1		T	I_{DDA}	—	202	—	μA		
Supply Current ADLPC=0 ADLSMP=1 ADCO=1		T	I_{DDA}	—	288	—	μA		
Supply Current ADLPC=0 ADLSMP=0 ADCO=1		D	I_{DDA}	—	0.532	1	mA		
Supply Current	Stop, Reset, Module Off	P	I_{DDA}	—	0.007	0.8	μA		
ADC Asynchronous Clock Source	High Speed (ADLPC=0)	P	f_{ADACK}	2	3.3	5	MHz	$t_{ADACK} = 1/f_{ADACK}$	
	Low Power (ADLPC=1)	P		1.25	2	3.3			
Conversion Time (Including sample time)	Short Sample (ADLSMP=0)	P	t_{ADC}	—	20	—	ADCK cycles	See the ADC chapter in the MC9S08QE128 <i>Reference Manual</i> for conversion time variances	
	Long Sample (ADLSMP=1)	C		—	40	—			
Sample Time	Short Sample (ADLSMP=0)	P	t_{ADS}	—	3.5	—	ADCK cycles		
	Long Sample (ADLSMP=1)	C		—	23.5	—			
Total Unadjusted Error	12-bit mode, $3.6 > V_{DDA} > 2.7$	T	E_{TUE}	—	-1 to 3	-2.5 to 5.5	LSB ²		Includes Quantization
	12-bit mode, $2.7 > V_{DDA} > 1.8V$	T		—	-1 to 3	-3.0 to 6.5			
	10 bit mode	P		—	± 1	± 2.5			
	8 bit mode	T		—	± 0.5	± 1.0			
Differential Non-Linearity	12 bit mode	T	DNL	—	± 1.0	-1.5 to 2.0	LSB ²		
	10 bit mode ³	P		—	± 0.5	± 1.0			
	8 bit mode ³	T		—	± 0.3	± 0.5			
Integral Non-Linearity	12 bit mode	T	INL	—	± 1.5	-2.5 to 2.75	LSB ²		
	10 bit mode	T		—	± 0.5	± 1.0			
	8 bit mode	T		—	± 0.3	± 0.5			
Zero-Scale Error	12 bit mode	T	E_{ZS}	—	± 1.5	± 2.5	LSB ²	$V_{ADIN} = V_{SSA}$	
	10 bit mode	P		—	± 0.5	± 1.5			
	8 bit mode	T		—	± 0.5	± 0.5			

Table 19. 12-bit ADC Characteristics ($V_{REFH} = V_{DDA_{SSA}}$, $V_{REFL} = V_{SSA}$) (continued)

Characteristic	Conditions	C	Symb	Min	Typ ¹	Max	Unit	Comment
Full-Scale Error	12 bit mode	T	E_{FS}	—	± 1.0	-3.5 to 1.0	LSB ²	$V_{ADIN} = V_{DDA}$
	10 bit mode	P		—	± 0.5	± 1		
	8 bit mode	T		—	± 0.5	± 0.5		
Quantization Error	12 bit mode	D	E_Q	—	-1 to 0	—	LSB ²	
	10 bit mode			—	—	± 0.5		
	8 bit mode			—	—	± 0.5		
Input Leakage Error	12 bit mode	D	E_{IL}	—	± 2	—	LSB ²	Pad leakage ⁴ * R_{AS}
	10 bit mode			—	± 0.2	± 4		
	8 bit mode			—	± 0.1	± 1.2		
Temp Sensor Slope	-40°C to 25°C	D	m	—	1.646	—	mV/°C	
	25°C to 85°C			—	1.769	—		
Temp Sensor Voltage	25°C	D	V_{TEMP25}	—	701.2	—	mV	

¹ Typical values assume $V_{DDA} = 3.0V$, Temp = 25°C, $f_{ADCK} = 1.0MHz$ unless otherwise stated. Typical values are for reference only and are not tested in production.

² 1 LSB = $(V_{REFH} - V_{REFL})/2^N$

³ Monotonicity and No-Missing-Codes guaranteed in 10 bit and 8 bit modes

⁴ Based on input pad leakage current. Refer to pad electricals.

8.5 Flash Specifications

This section provides details about program/erase times and program-erase endurance for the flash memory.

Program and erase operations do not require any special power sources other than the normal V_{DD} supply. For more detailed information about program/erase operations, see the Memory section of the *MC9S08QE128 Reference Manual*.

Table 20. Flash Characteristics

C	Characteristic	Symbol	Min	Typical	Max	Unit
D	Supply voltage for program/erase -40°C to 85°C	$V_{prog/erase}$	1.8		3.6	V
D	Supply voltage for read operation	V_{Read}	1.8		3.6	V
D	Internal FCLK frequency ¹	f_{FCLK}	150		200	KHz
D	Internal FCLK period (1/FCLK)	t_{FcyC}	5		6.67	μs
P	Byte program time (random location) ⁽²⁾	t_{prog}		9		t_{FcyC}
P	Byte program time (burst mode) ⁽²⁾	t_{Burst}		4		t_{FcyC}
P	Page erase time ²	t_{Page}		4000		t_{FcyC}
P	Mass erase time ⁽²⁾	t_{Mass}		20,000		t_{FcyC}

Table 20. Flash Characteristics (continued)

C	Characteristic	Symbol	Min	Typical	Max	Unit
	Byte program current ³	R _{IDDBP}	—	4	—	mA
	Page erase current ³	R _{IDDPE}	—	6	—	mA
C	Program/erase endurance ⁴ T _L to T _H = -40°C to + 85°C T = 25°C		10,000 —	— 100,000	— —	cycles
C	Data retention ⁵	t _{D_ret}	15	100	—	years

¹ The frequency of this clock is controlled by a software setting.

² These values are hardware state machine controlled. User code does not need to count cycles. This information supplied for calculating approximate time to program and erase.

³ The program and erase currents are additional to the standard run I_{DD}. These values are measured at room temperatures with V_{DD} = 3.0 V, bus frequency = 4.0 MHz.

⁴ **Typical endurance for flash** was evaluated for this product family on the HC9S12Dx64. For additional information on how Freescale defines typical endurance, please refer to Engineering Bulletin EB619, *Typical Endurance for Nonvolatile Memory*.

⁵ **Typical data retention** values are based on intrinsic capability of the technology measured at high temperature and de-rated to 25°C using the Arrhenius equation. For additional information on how Freescale defines typical data retention, please refer to Engineering Bulletin EB618, *Typical Data Retention for Nonvolatile Memory*.

8.5.1 Onboard System SPI Timing

Table 21. SPI Timing

No.	Function	Symbol	Min	Max	Unit
	Operating frequency Master	f _{op}	f _{Bus} /2048	10	MHz
1	SCK period Master	t _{SCK}	2	2048	t _{cyc}
2	Enable lead time Master	t _{Lead}	1/2	—	t _{SCK}
3	Enable lag time Master	t _{Lag}	1/2	—	t _{SCK}
4	Clock (SCK) high or low time Master	t _{WSCK}	62.5	1024 t _{cyc}	ns
5	Data setup time (inputs) Master	t _{SU}	15	—	ns
6	Data hold time (inputs) Master	t _{HI}	0	—	ns
7	Data valid (after SCK edge) Master	t _v	—	25	ns
8	Data hold time to transceiver	t _{HO}	250	—	ns
9	Slave Select high time between accesses	t _{nhigh}	20	—	ns

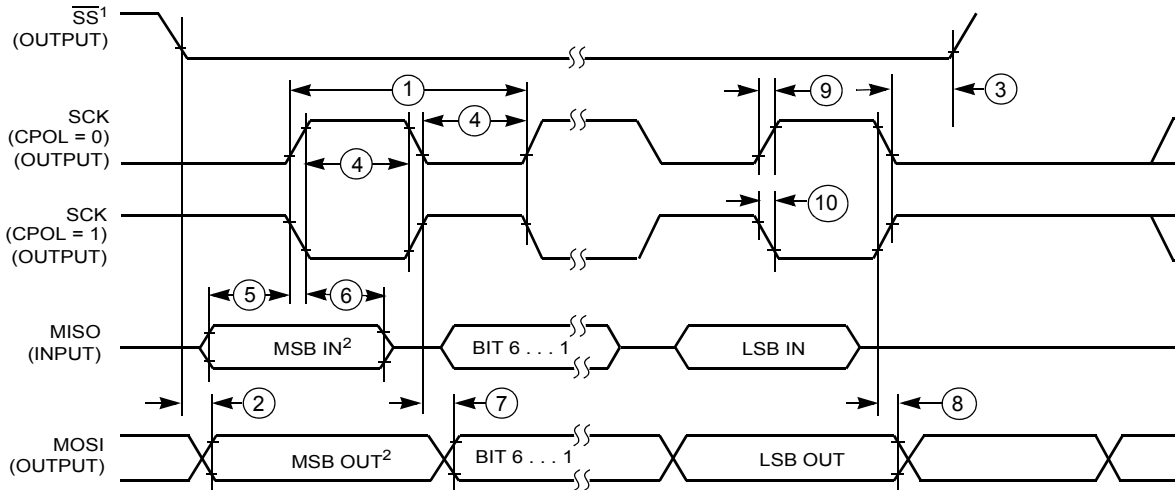

Figure 18. Onboard SPI Timing

9 Typical Applications Circuit

Figure 19 show a MC12311 typical applications circuit with and without use of an external power amplifier (PA) (driven by the RF power boost feature). Note a number of circuit features:

1. The two metal flags on the package bottom are independent (unconnected), and as a result, both must be connected to ground.
2. The topology of the external RF matching components is consistent across various frequency bandwidths. Only the component values differ as determined by the desired frequency range.
3. Freescale recommends using a single crystal design (as shown) to minimize systems costs - the circuit must connect transceiver signal DIO5/CLKOUT to the MCU EXTAL input to supply the MCU with a crystal accurate clock source. Also, the MCU initialization must enable the DIO5 pin as the ClkOut function.
4. Freescale also recommends that the transceiver RESET is driven by an MCU GPIO to provide total hardware control of the transceiver. Figure 19 shows GPIO PTC0 (preferred), but any GPIO can be used.
5. The MC12311 provides onboard connection for the DIO1-DIO0 status to the MCU. External connection of DIO4-DIO2 status to MCU GPIO may be useful or required to implement a wireless node communication algorithm.
6. The transceiver reference oscillator uses the specified 32 MHz crystal (pins XTA and XTB).
7. A debug port connector is provided for programming the 9S08QE32 MCU FLASH and debugging code.
8. A simple UART interface (without flow control) is shown that is useful for a command/communication channel interface or for system debug.

Two common RF wiring options are shown in Figure 19:

1. Bi-directional single port operation - this mode uses the bi-directional RF port pin of the MC12311 designated as RFIO. The device transmits and receives through this single port.

- Typical +13 dBm TX output power
- Inductor L6 acts to provide DC power to the onboard transmitter while also acting as an AC signal block.
- The circuit topology defined by inductors L7, L4 and L2 as well as capacitors C15, C13, C11, C7, C9, and C4 can provide:
 - Impedance matching between the RFIO port and the antenna
 - Low pass filtering for the onboard transmitter - when fully populated can implement an elliptic-function low pass filter.

NOTE

- The topology for the RF matching network can be used over the various bands of interest with changes in component values
 - Not all indicated components are used at all frequencies
 - Refer to *MC12311Sub 1 GHz Low Power Transceiver plus Microcontroller Reference Manual* (MC12311RM.pdf) for additional information
2. Dual port operation with external amplification - this mode uses the RFIO port pin of the MC12311 typically as the RX input and the auxiliary port PA_BOOST as the TX output. An external PA can optionally be inserted into the transmit path and an external antenna switch is also required.
- The PA_BOOST has typical +17 dBm output power - this is +4 dBm higher than the RFIO and helps achieve higher power at the PA output
 - The PA_BOOST transmit path has a similar filter matching network discussed in the single-port to do low pass filtering and impedance match. The above note about components values also applies.
 - With separate transmit and receive paths, an antenna switch is required - the RXTX signal or another programmed GPIO can be used to switch paths depending on radio operation.
 - The receive side matching network can be simplified as no low pass filtering or harmonic trapping is required as with the transmit and single port networks

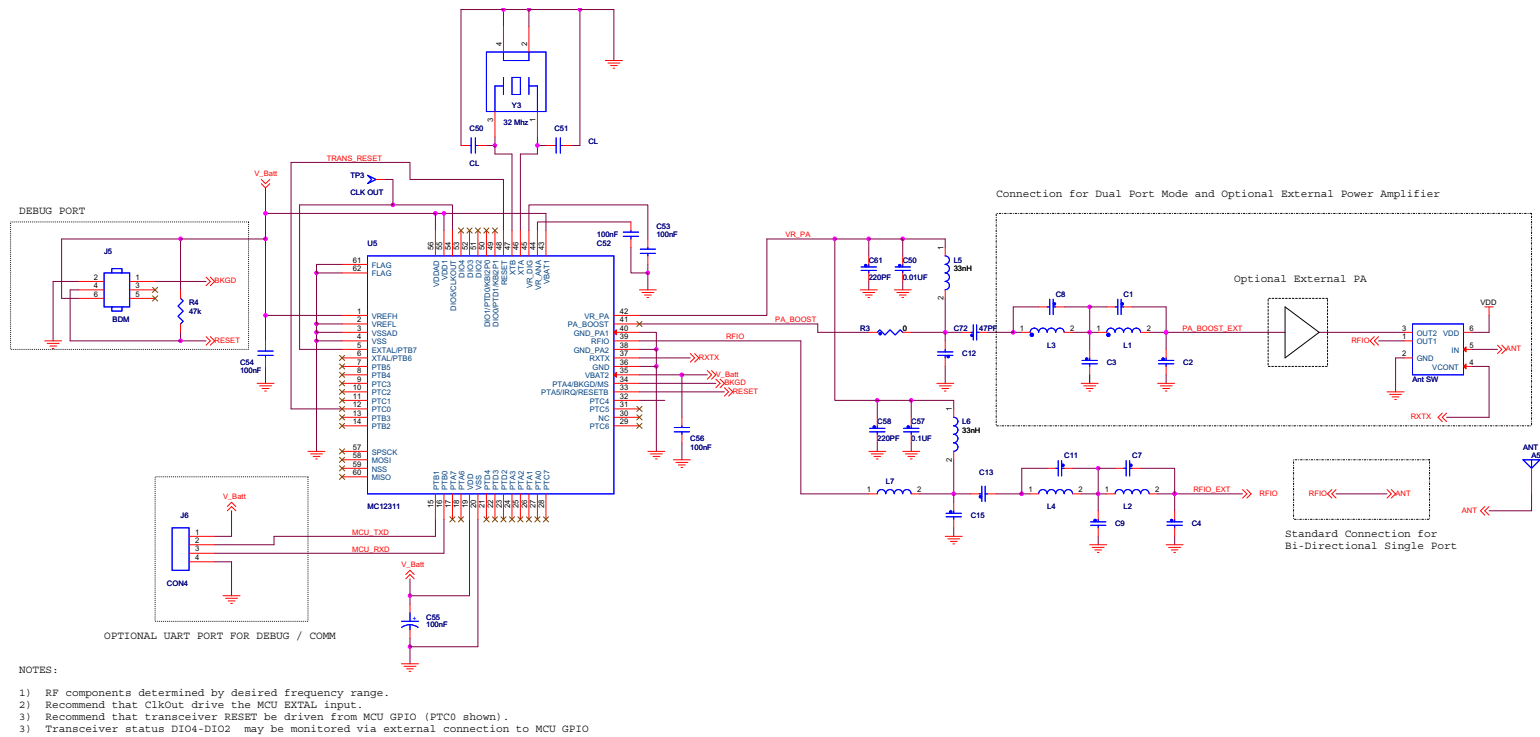

Figure 19. MC12311 Typical Application Circuit Options

10 Mechanical Drawings

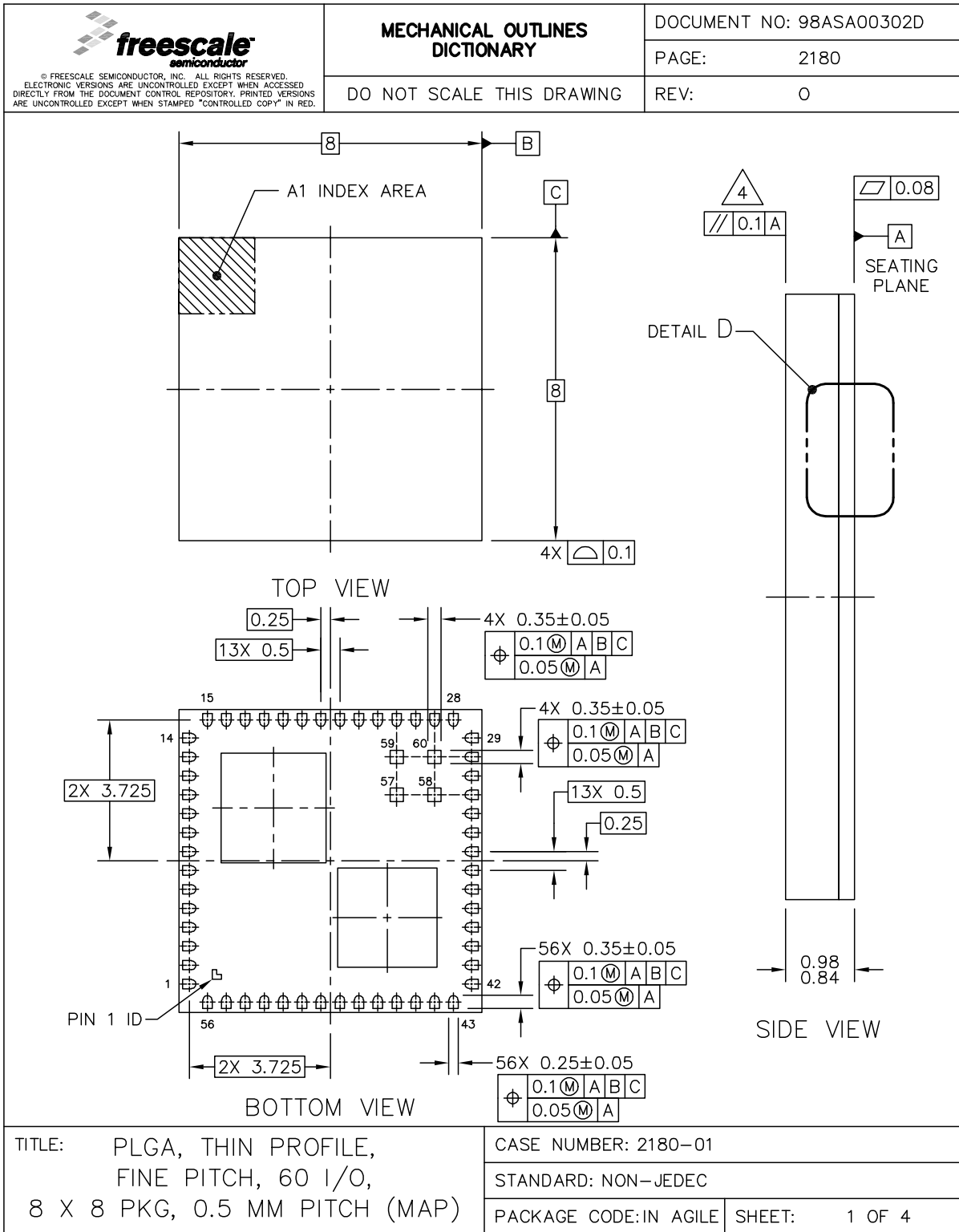
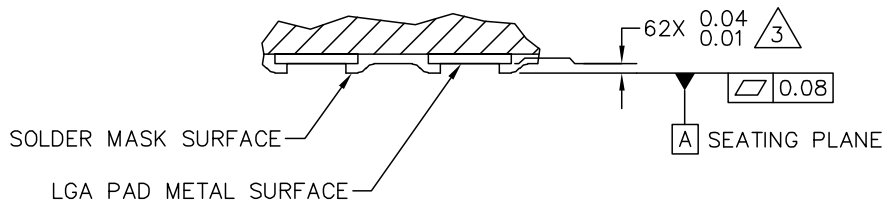
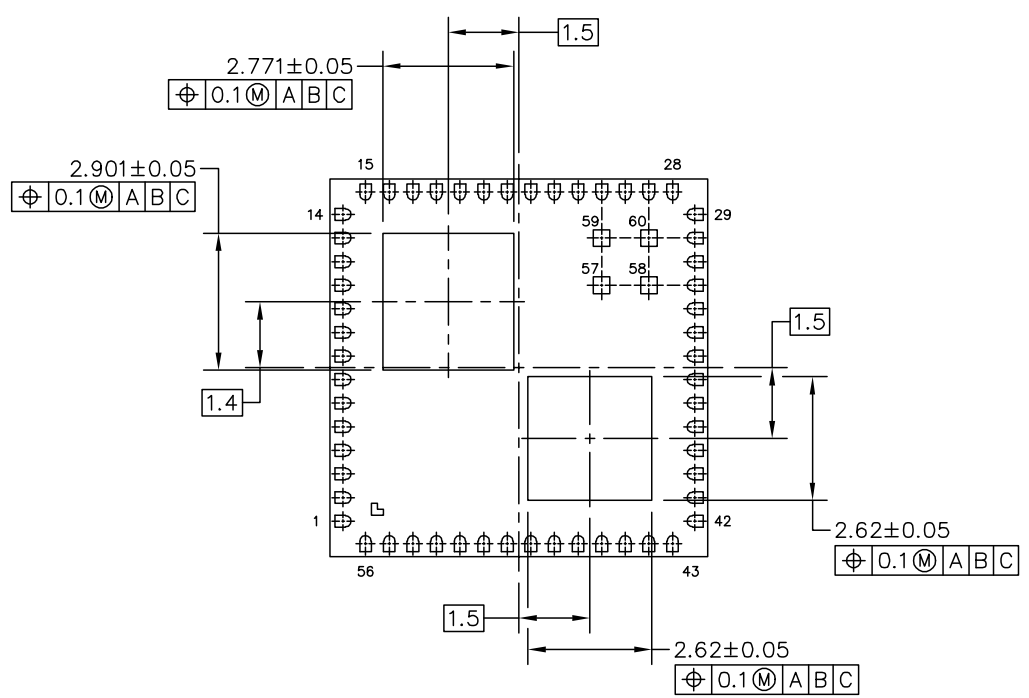

Figure 20. Mechanical Drawing (1 of 2)

<p>© FREESCALE SEMICONDUCTOR, INC. ALL RIGHTS RESERVED. ELECTRONIC VERSIONS ARE UNCONTROLLED EXCEPT WHEN ACCESSED DIRECTLY FROM THE DOCUMENT CONTROL REPOSITORY. PRINTED VERSIONS ARE UNCONTROLLED EXCEPT WHEN STAMPED "CONTROLLED COPY" IN RED.</p>	MECHANICAL OUTLINES DICTIONARY	DOCUMENT NO: 98ASA00302D
		PAGE: 2180
	DO NOT SCALE THIS DRAWING	REV: 0



DETAIL D
VIEW ROTATED 90° CW



BOTTOM VIEW

TITLE: PLGA, THIN PROFILE, FINE PITCH, 60 I/O, 8 X 8 PKG, 0.5 MM PITCH (MAP)	CASE NUMBER: 2180-01	
	STANDARD: NON-JEDEC	
	PACKAGE CODE: IN AGILE	SHEET: 2

Figure 21. Mechanical Drawing (2 of 2)

NOTES

How to Reach Us:

Home Page:
www.freescale.com

E-mail:
support@freescale.com

USA/Europe or Locations Not Listed:
Freescale Semiconductor
Technical Information Center, CH370
1300 N. Alma School Road
Chandler, Arizona 85224
+1-800-521-6274 or +1-480-768-2130
support@freescale.com

Europe, Middle East, and Africa:
Freescale Halbleiter Deutschland GmbH
Technical Information Center
Schatzbogen 7
81829 Muenchen, Germany
+44 1296 380 456 (English)
+46 8 52200080 (English)
+49 89 92103 559 (German)
+33 1 69 35 48 48 (French)
support@freescale.com

Japan:
Freescale Semiconductor Japan Ltd.
Headquarters
ARCO Tower 15F
1-8-1, Shimo-Meguro, Meguro-ku,
Tokyo 153-0064, Japan
0120 191014 or +81 3 5437 9125
support.japan@freescale.com

Asia/Pacific:
Freescale Semiconductor Hong Kong Ltd.
Technical Information Center
2 Dai King Street
Tai Po Industrial Estate
Tai Po, N.T., Hong Kong
+800 2666 8080
support.asia@freescale.com

For Literature Requests Only:
Freescale Semiconductor Literature Distribution Center
P.O. Box 5405
Denver, Colorado 80217
1-800-521-6274 or 303-675-2140
Fax: 303-675-2150
LDCForFreescaleSemiconductor@hibbertgroup.com

Information in this document is provided solely to enable system and software implementers to use Freescale Semiconductor products. There are no express or implied copyright licenses granted hereunder to design or fabricate any integrated circuits or integrated circuits based on the information in this document.

Freescale Semiconductor reserves the right to make changes without further notice to any products herein. Freescale Semiconductor makes no warranty, representation or guarantee regarding the suitability of its products for any particular purpose, nor does Freescale Semiconductor assume any liability arising out of the application or use of any product or circuit, and specifically disclaims any and all liability, including without limitation consequential or incidental damages. "Typical" parameters that may be provided in Freescale Semiconductor data sheets and/or specifications can and do vary in different applications and actual performance may vary over time. All operating parameters, including "Typicals", must be validated for each customer application by customer's technical experts. Freescale Semiconductor does not convey any license under its patent rights nor the rights of others. Freescale Semiconductor products are not designed, intended, or authorized for use as components in systems intended for surgical implant into the body, or other applications intended to support or sustain life, or for any other application in which the failure of the Freescale Semiconductor product could create a situation where personal injury or death may occur. Should Buyer purchase or use Freescale Semiconductor products for any such unintended or unauthorized application, Buyer shall indemnify and hold Freescale Semiconductor and its officers, employees, subsidiaries, affiliates, and distributors harmless against all claims, costs, damages, and expenses, and reasonable attorney fees arising out of, directly or indirectly, any claim of personal injury or death associated with such unintended or unauthorized use, even if such claim alleges that Freescale Semiconductor was negligent regarding the design or manufacture of the part.

Freescale™ and the Freescale logo are trademarks of Freescale Semiconductor, Inc. All other product or service names are the property of their respective owners.

© Freescale Semiconductor, Inc. 2010, 2011. All rights reserved.



Компания «ЭлектроПласт» предлагает заключение долгосрочных отношений при поставках импортных электронных компонентов на взаимовыгодных условиях!

Наши преимущества:

- Оперативные поставки широкого спектра электронных компонентов отечественного и импортного производства напрямую от производителей и с крупнейших мировых складов;
- Поставка более 17-ти миллионов наименований электронных компонентов;
- Поставка сложных, дефицитных, либо снятых с производства позиций;
- Оперативные сроки поставки под заказ (от 5 рабочих дней);
- Экспресс доставка в любую точку России;
- Техническая поддержка проекта, помощь в подборе аналогов, поставка прототипов;
- Система менеджмента качества сертифицирована по Международному стандарту ISO 9001;
- Лицензия ФСБ на осуществление работ с использованием сведений, составляющих государственную тайну;
- Поставка специализированных компонентов (Xilinx, Altera, Analog Devices, Intersil, Interpoint, Microsemi, Aeroflex, Peregrine, Syfer, Eurofarad, Texas Instrument, Miteq, Cobham, E2V, MA-COM, Hittite, Mini-Circuits, General Dynamics и др.);

Помимо этого, одним из направлений компании «ЭлектроПласт» является направление «Источники питания». Мы предлагаем Вам помощь Конструкторского отдела:

- Подбор оптимального решения, техническое обоснование при выборе компонента;
- Подбор аналогов;
- Консультации по применению компонента;
- Поставка образцов и прототипов;
- Техническая поддержка проекта;
- Защита от снятия компонента с производства.



Как с нами связаться

Телефон: 8 (812) 309 58 32 (многоканальный)

Факс: 8 (812) 320-02-42

Электронная почта: org@eplast1.ru

Адрес: 198099, г. Санкт-Петербург, ул. Калинина, дом 2, корпус 4, литера А.