

HCPL-250L/050L/253L/053L

LVTTTL/LVCMOS Compatible 3.3 V Optocouplers (1 Mb/s)



Data Sheet



Description

These diode-transistor optocouplers use an insulating layer between a LED and an integrated photodetector to provide electrical insulation between input and output. Separate connections for the photodiode bias and output-transistor collector increase the speed up to a hundred times that of a conventional photo-transistor coupler by reducing the base-collector capacitance.

These optocouplers are available in an 8-pin DIP and in an industry standard SO-8 package. The following is a cross reference table listing the 8-pin DIP part number and the electrically equivalent SO-8 part number.

The SO-8 does not require "through holes" in a PCB. This package occupies approximately one-third the footprint area of the standard dual-in-line package. The lead profile is designed to be compatible with standard surface mount processes.

These optocouplers can be used in LVTTTL/LVCMOS or wide bandwidth analog applications.

The common mode transient immunity of 1000 V/ μ s minimum to typical at VCM = 10 V guaranteed for these optocouplers.

| 8-Pin DIP | SO-8 Package |
|-----------|--------------|
| HCPL-250L | HCPL-050L |
| HCPL-253L | HCPL-053L |

Features

- 3.3V/5V Dual Supply Voltages
- Low power consumption
- High speed: 1 Mb/s
- LVTTTL/LVCMOS compatible
- Available in 8-pin DIP, SO-8
- Open collector output
- Guaranteed performance from temperature: 0°C to +70°C
- Safety approval, UL, CSA, IEC/EN/DIN EN 60747-5-2

Applications

- High voltage insulation
- Video signal isolation
- Power translator isolation in motor drives
- Line receivers
- Feedback element in switched mode power supplies
- High speed logic ground isolation – LVTTTL/LVCMOS
- Replaces pulse transformers
- Replaces slow phototransistor isolators

Functional Diagram

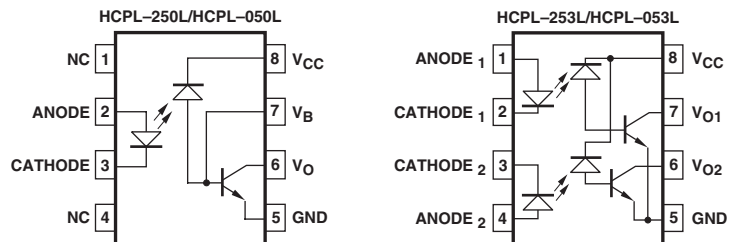

TRUTH TABLE
(POSITIVE LOGIC)

| LED | V _O |
|-----|----------------|
| ON | LOW |
| OFF | HIGH |

A 0.1 μ F bypass capacitor must be connected between pins 5 and 8.

CAUTION: It is advised that normal static precautions be taken in handling and assembly of this component to prevent damage and/or degradation which may be induced by ESD.

Ordering Information

HCPL-250L, HCPL-253L, HCPL-050L and HCPL-053L are UL Recognized with 3750 Vrms for 1 minute per UL1577 and are approved under CSA Component Acceptance Notice #5, File CA 88324.

| Part Number | Option | | Package | Surface Mount | Gull Wing | Tape & Reel | UL 5000 Vrms/ 1 Minute rating | IEC/EN/DIN EN 60747-5-2 | Quantity |
|-------------|----------------|--------------------|---------------|---------------|-----------|-------------|----------------------------------|----------------------------|---------------|
| | RoHS Compliant | non RoHS Compliant | | | | | | | |
| | -000E | no option | 300 mil DIP-8 | | | | | | 50 per tube |
| | -300E | -300 | | X | X | | | | 50 per tube |
| | -500E | -500 | | X | X | X | | | 1000 per reel |
| HCPL-250L | -020E | -020 | | | | | X | | 50 per tube |
| HCPL-253L | -320E | -320 | | X | X | | X | | 50 per tube |
| | -520E | -520 | | X | X | X | X | | 1000 per reel |
| | -060E | -060 | | | | | | X | 50 per tube |
| | -360E | -360 | | X | X | | | X | 50 per tube |
| | -560E | -560 | | X | X | X | | X | 1000 per reel |
| HCPL-050L | -000E | no option | SO-8 | | | | | | 100 per tube |
| HCPL-053L | -500E | -500 | | X | X | X | | | 1500 per reel |

To order, choose a part number from the part number column and combine with the desired option from the option column to form an order entry.

Example 1:

HCPL-253L-560E to order product of 300 mil DIP Gull Wing Surface Mount package in Tape and Reel packaging with IEC/EN/DIN EN 60747-5-2 Safety Approval and RoHS compliant.

Example 2:

HCPL-253L to order product of 300 mil DIP package in Tube packaging and non RoHS compliant.

Option datasheets are available. Contact your Avago sales representative or authorized distributor for information. Remarks: The notation '#XXX' is used for existing products, while (new) products launched since July 15, 2001 and RoHS compliant will use '-XXE'.

Schematic

HCPL-250L/HCPL-050L



HCPL-253L/HCPL-053L

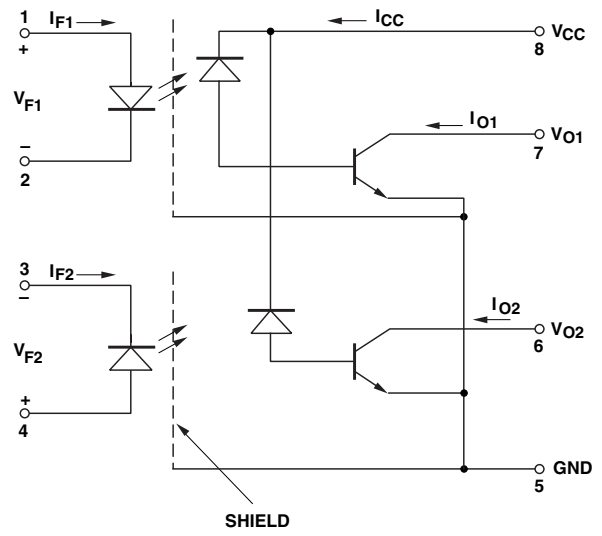

Package Outline Drawings

8-Pin DIP Package



DIMENSIONS IN MILLIMETERS AND (INCHES).
 * MARKING CODE LETTER FOR OPTION NUMBERS
 "V" = OPTION 060
 OPTION NUMBERS 300 AND 500 NOT MARKED.

NOTE: FLOATING LEAD PROTRUSION IS 0.25 mm (10 mils) MAX.

Small Outline SO-8 Package



* TOTAL PACKAGE LENGTH (INCLUSIVE OF MOLD FLASH)
 5.207 ± 0.254 (0.205 ± 0.010)

DIMENSIONS IN MILLIMETERS (INCHES).
 LEAD COPLANARITY = 0.10 mm (0.004 INCHES) MAX.

OPTION NUMBER 500 NOT MARKED.

NOTE: FLOATING LEAD PROTRUSION IS 0.15 mm (6 mils) MAX.

Solder Reflow Temperature Profile

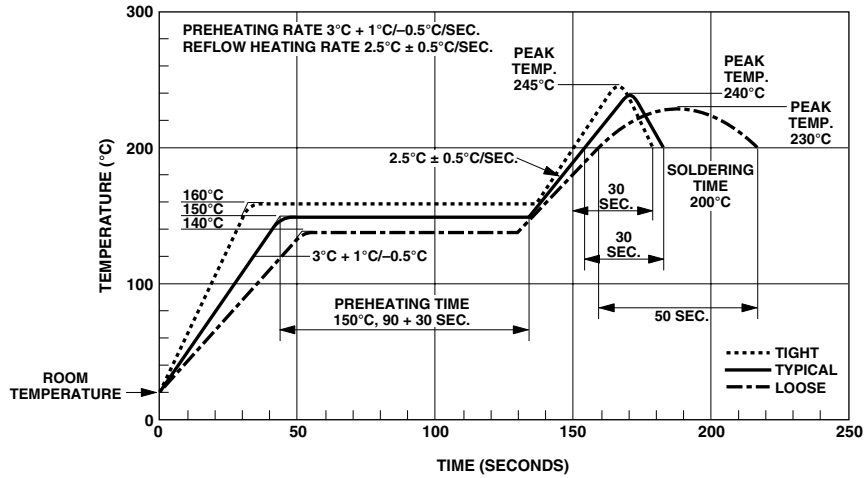

Note: Non-halide flux should be used.

Recommended Pb-Free IR Profile

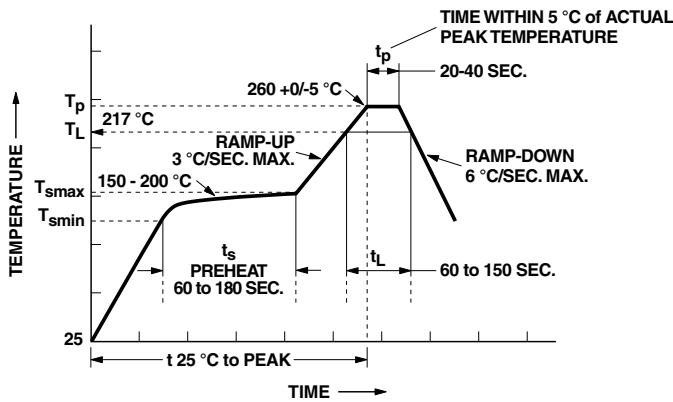

NOTES:
 THE TIME FROM 25 °C to PEAK TEMPERATURE = 8 MINUTES MAX.
 $T_{smax} = 200^{\circ}\text{C}$, $T_{smin} = 150^{\circ}\text{C}$

Note: Non-halide flux should be used.

Regulatory Information

The devices contained in this data sheet have been approved by the following organizations:

UL

Approval under UL 1577, Component Recognition Program, File E55361.

CSA

Approval under CSA Component Acceptance Notice #5, File CA 88324.

IEC/EN/DIN EN 60747-5-2

Approved under :

IEC 60747-5-2:1997 + A1:2002

EN 60747-5-2:2001 + A1:2002

DIN EN 60747-5-2 (VDE 0884Teil 2):2003-01

Insulation and Safety Related Specifications

| Parameter | Symbol | 8-Pin DIP (300 Mil) | SO-8 | Units | Conditions |
|---|---------|------------------------|-------|-------|--|
| | | Value | Value | | |
| Minimum External Air Gap (External Clearance) | L (101) | 7.1 | 4.9 | mm | Measured from input terminals to output terminals, shortest distance through air. |
| Minimum External Tracking (External Creepage) | L (102) | 7.4 | 4.8 | mm | Measured from input terminals to output terminals, shortest distance path along body. |
| Minimum Internal Plastic Gap (Internal Clearance) | | 0.08 | 0.08 | mm | Through insulation distance, conductor to conductor, usually the direct distance between the photoemitter and photodetector inside the optocoupler cavity. |
| Tracking Resistance (Comparative Tracking Index) | CTI | 200 | 200 | Volts | DIN IEC 112/VDE 0303 Part 1 |
| Isolation Group | | IIIa | IIIa | | Material Group (DIN VDE 0110, 1/89, Table 1) |

IEC/EN/DIN EN 60747-5-2 Insulation Related Characteristics

| Description | Symbol | PDIP Option 060 | SO-8 Option 60 | Units |
|---|----------------|-----------------|-----------------------|------------|
| Installation classification per DIN VDE 0110/1.89, Table 1 for rated mains voltage ≤ 150 V rms for rated mains voltage ≤ 300 V rms for rated mains voltage ≤ 600 V rms | | | I-IV I-III I-II | |
| Climatic Classification | | 55/85/21 | 55/85/21 | |
| Pollution Degree (DIN VDE 0110/1.89) | | 2 | 2 | |
| Maximum Working Insulation Voltage | V_{IORM} | 630 | 566 | V_{peak} |
| Input to Output Test Voltage, Method b* $V_{IORM} \times 1.875 = V_{PR}$, 100% Production Test with $t_m = 1$ sec, Partial Discharge < 5 pC | V_{PR} | 1181 | 1063 | V_{peak} |
| Input to Output Test Voltage, Method a* $V_{IORM} \times 1.5 = V_{PR}$, Type and Sample Test, $t_m = 60$ sec, Partial Discharge < 5 pC | V_{PR} | 945 | 849 | V_{peak} |
| Highest Allowable Overvoltage* (Transient Overvoltage, $t_{ini} = 10$ sec) | V_{IOTM} | 6000 | 4000 | V_{peak} |
| Safety Limiting Values (Maximum values allowed in the event of a failure, also see Figure 16, Thermal Derating curve.) | | | | |
| Case Temperature | T_S | 175 | 150 | °C |
| Input Current | $I_{S,INPUT}$ | 230 | 150 | mA |
| Output Power | $P_{S,OUTPUT}$ | 600 | 600 | mW |
| Insulation Resistance at T_S , $V_{IO} = 500$ V | R_S | $\geq 10^9$ | $\geq 10^9$ | Ω |

*Refer to the front of the optocoupler section of the current catalog, under Product Safety Regulations section, IEC/EN/DIN EN 60747-5-2, for a detailed description.

Note: Isolation characteristics are guaranteed only within the safety maximum ratings which must be ensured by protective circuits in application.

Absolute Maximum Ratings

| Parameter | Symbol | Min. | Max. | Units | Note |
|--|-----------------------------|--------------------------------------|------------|----------|------|
| Storage Temperature | T _S | -55 | 125 | °C | |
| Operating Temperature | T _A | -55 | 100 | °C | |
| Average Forward Input Current | I _{F(AVG)} | | 25 | mA | 1 |
| Peak Forward Input Current (50% duty cycle, 1 ms pulse width) | I _{F(PEAK)} | | 50 | mA | 2 |
| Peak Transient Input Current (≤ 1 μs pulse width, 300 pps) | I _{F(TRANS)} | | 1 | A | |
| Reverse LED Input Voltage (Pin 3-2) | V _R | | 5 | V | |
| Input Power Dissipation | P _{IN} | | 45 | mW | 3 |
| Average Output Current (Pin 6) | I _{O(AVG)} | | 8 | mA | |
| Peak Output Current | I _{O(PEAK)} | | 16 | mA | |
| Emitter-Base Reverse Voltage | V _{E_{BR}} | | 5 | V | |
| Supply Voltage (Pin 8-5) | V _{CC} | -0.5 | 7 | V | |
| Output Voltage (Pin 6-5) | V _O | -0.5 | 7 | V | |
| Base Current | I _B | | 5 | mA | |
| Output Power Dissipation | P _O | | 100 | mW | 4 |
| Lead Solder Temperature (Through Hole Parts Only) 1.6 mm below seating plane, 10 sec. up to seating plane, 10 seconds | T _{LS} | | 260 260 | °C °C | |
| Reflow Temperature Profile | T _{RP} | See Package Outline Drawings section | | | |

Recommended Operating Conditions

| Parameter | Symbol | Min. | Max. | Units |
|-----------------------|---------------------|------|------|-------|
| Power Supply Voltage | V _{CC} | 2.7 | 7.0 | V |
| Forward Input Current | I _{F(ON)} | 16 | 20 | mA |
| Forward Input Voltage | V _{F(OFF)} | 0 | 0.8 | V |
| Operating Temperature | T _A | 0 | 85 | °C |

Electrical Specifications (DC)

Over Recommended Temperature ($T_A = 0^\circ\text{C}$ to $+70^\circ\text{C}$), $V_{CC} = 3.3\text{ V}$, $I_F = 16\text{ mA}$, unless otherwise specified. See Note 13.

| Parameter | Sym. | Device | Min. | Typ. | Max. | Units | Test Conditions | Fig. | Note |
|---------------------------------|-----------|--|------|-------|------|---------------|---|------|-------|
| Current Transfer Ratio | CTR | | 15 | 20 | 50 | % | $T_A = 25^\circ\text{C}$ $V_O = 0.4\text{ V}$ $I_F = 16\text{ mA}$, $V_{CC} = 3.3\text{ V}$ | 2 | 5, 11 |
| Logic Low Output Voltage | V_{OL} | | | 0.05 | 0.3 | V | $T_A = 25^\circ\text{C}$ $I_O = 3.0\text{ mA}$ $I_F = 16\text{ mA}$, $V_{CC} = 3.3\text{ V}$ | | |
| Logic High Output Current | I_{OH} | | | 0.003 | 1 | μA | $T_A = 25^\circ\text{C}$ $V_O = V_{CC} = 3.3\text{ V}$ $I_F = 0\text{ mA}$ | 4 | |
| Logic Low Supply Current | I_{CCL} | HCPL-050L HCPL-250L HCPL-053L HCPL-253L | | 43.0 | 100 | μA | $I_F = 16\text{ mA}$, $V_O = \text{Open}$, $V_{CC} = 3.3\text{ V}$ | | 13 |
| Logic High Supply Current | I_{CCH} | HCPL-050L HCPL-250L HCPL-053L HCPL-253L | | 0.005 | 0.3 | μA | $T_A = 25^\circ\text{C}$ $I_F = 0\text{ mA}$, $V_O = \text{Open}$, $V_{CC} = 3.3\text{ V}$ | | 13 |
| Input Forward Voltage | V_F | | | 1.52 | 1.7 | V | $T_A = 25^\circ\text{C}$ $I_F = 16\text{ mA}$ | | 1 |
| Input Reverse Breakdown Voltage | BV_R | | 5 | | | V | $I_R = 10\ \mu\text{A}$ | | |
| Input Capacitance | C_{IN} | | | 60 | | pF | $f = 1\text{ MHz}$, $V_F = 0\text{ V}$ | | |

Electrical Specifications (DC)

Over Recommended DC Temperature ($T_A = 0^\circ\text{C}$ to $+70^\circ\text{C}$, $V_{CC} = 5\text{ V}$, $I_F = 16\text{ mA}$) unless otherwise specified. (See note 13.)

| Parameter | Sym. | Device | Min. | Typ.* | Max. | Units | Test Conditions | Fig. | Note |
|---------------------------------|-----------|--|------|-------|------|---------------|---|------|-------|
| Current Transfer Ratio | CTR | HCPL-050L HCPL-250L HCPL-053L HCPL-253L | 19 | 24 | 50 | % | $V_O = 0.4\text{ V}$ $T_A = 25^\circ\text{C}$, $V_{CC} = 4.5\text{ V}$, $I_F = 16\text{ mA}$ | 3 | 5, 11 |
| Logic Low Output Voltage | V_{OL} | HCPL-050L HCPL-250L HCPL-053L HCPL-253L | | 0.1 | 0.4 | V | $I_O = 3.0\text{ mA}$ $T_A = 25^\circ\text{C}$, $I_F = 16\text{ mA}$, $V_{CC} = 4.5\text{ V}$ | | |
| Logic High Output Current | I_{OH} | | | 0 | 0.5 | μA | $V_O = V_{CC} = 5.5\text{ V}$ $T_A = 25^\circ\text{C}$ | 5 | |
| Logic Low Supply Current | I_{CCL} | HCPL-050L HCPL-250L HCPL-053L HCPL-253L | | 50 | 200 | μA | $V_{CC} = 7\text{ V}$ $I_F = 16\text{ mA}$ $V_O = \text{Open}$ | | 13 |
| Logic High Supply Current | I_{CCH} | HCPL-050L HCPL-250L HCPL-053L HCPL-253L | | 0.02 | 1 | μA | $T_A = 25^\circ\text{C}$ $I_F = 0\text{ mA}$ $V_O = \text{Open}$ $V_{CC} = 7\text{ V}$ | | 13 |
| Input Forward Voltage | V_F | | | 1.5 | 1.7 | V | $T_A = 25^\circ\text{C}$ $I_F = 16\text{ mA}$ | | 1 |
| Input Reverse Breakdown Voltage | BV_R | | 5 | | | V | $I_R = 10\ \mu\text{A}$ | | |
| Input Capacitance | C_{IN} | | | 60 | | pF | $f = 1\text{ MHz}$, $V_F = 0$ | | |

*All typical values at $T_A = 25^\circ\text{C}$

Switching Specifications (AC)

Over Recommended Temperature ($T_A = 0^\circ\text{C}$ to $+70^\circ\text{C}$), $V_{CC} = 3.3\text{ V}$, $I_F = 16\text{ mA}$ unless otherwise specified.
All typicals at $V_{CC} = 3.3\text{ V}$, $T_A = 25^\circ\text{C}$.

| Parameter | Sym. | Device | Min. | Typ.* | Max. | Units | Test Conditions | Fig. | Note |
|---|-----------|--------|------|-------|------|-------------------------|---|------|---------|
| Propagation Delay Time to Logic Low at Output | t_{PHL} | | | 0.35 | 1 | μs | $R_L = 1.9\text{ k}\Omega$ | 7 | 8, 9 |
| Propagation Delay Time to Logic High at Output | t_{PLH} | | | 0.65 | 1 | μs | $R_L = 1.9\text{ k}\Omega$ | 7 | 8, 9 |
| Common Mode Transient Immunity at Logic High Level Output | $ CM_H $ | | | 1 | | $\text{kV}/\mu\text{s}$ | $R_L = 4.1\text{ k}\Omega$ $R_L = 1.9\text{ k}\Omega$ $I_F = 0\text{ mA}$, $T_A = 25^\circ\text{C}$, $V_{CM} = 10\text{ V}_{p-p}$ $C_L = 15\text{ pF}$ | 8 | 7, 8, 9 |
| Common Mode Transient Immunity at Logic Low Level Output | $ CM_L $ | | | 1 | | $\text{kV}/\mu\text{s}$ | $R_L = 4.1\text{ k}\Omega$ $R_L = 1.9\text{ k}\Omega$ $I_F = 16\text{ mA}$, $T_A = 25^\circ\text{C}$, $V_{CM} = 10\text{ V}_{p-p}$ $C_L = 15\text{ pF}$ | 8 | 7, 8, 9 |

*All typicals at $T_A = 25^\circ\text{C}$

Switching Specifications (AC)

Over Recommended Temperature ($T_A = 0^\circ\text{C}$ to $+70^\circ\text{C}$, $V_{CC} = 5\text{ V}$, $I_F = 16\text{ mA}$, unless otherwise specified.

| Parameter | Sym. | Device | Min. | Typ.* | Max. | Units | Test Conditions | Fig. | Note |
|---|-----------|--------|------|-------|------|-------------------------|--|------|-------|
| Propagation Delay Time to Logic Low at Output | t_{PHL} | | | 0.2 | 0.8 | μs | $T_A = 25^\circ\text{C}$, $R_L = 1.9\text{ k}\Omega$ | 7 | 8,9 |
| Propagation Delay Time to Logic High at Output | t_{PLH} | | | 0.6 | 0.8 | μs | $T_A = 25^\circ\text{C}$, $R_L = 1.9\text{ k}\Omega$ | 7 | 8,9 |
| Common Mode Transient Immunity at Logic High Output | $ CM_H $ | | | 1 | | $\text{kV}/\mu\text{s}$ | $R_L = 1.9\text{ k}\Omega$ $I_F = 0\text{ mA}$, $T_A = 25^\circ\text{C}$, $ V_{CM} = 10\text{ V}_{p-p}$ $C_L = 15\text{ pF}$ | 8 | 7,8,9 |
| Common Mode Transient Immunity at Logic Low Output | $ CM_L $ | | | 1 | | $\text{kV}/\mu\text{s}$ | $R_L = 1.9\text{ k}\Omega$ $I_F = 16\text{ mA}$, $T_A = 25^\circ\text{C}$, $ V_{CM} = 10\text{ V}_{p-p}$ | 8 | 7,8,9 |

*All typical values at $T_A = 25^\circ\text{C}$

Package Characteristics

Over Recommended Temperature ($T_A = 0^\circ\text{C}$ to 70°C) unless otherwise specified.

| Parameter | Sym. | Device | Min. | Typ.* | Max. | Units | Test Conditions | Fig. | Note |
|--|-----------|-------------------|------|------------------|------|---------------|---|------|-------|
| Input-Output Momentary Withstand Voltage** | V_{ISO} | 8-Pin DIP SO-8 | 3750 | | | V rms | RH < 50%, t = 1 min., $T_A = 25^\circ\text{C}$ | | 6, 14 |
| | I_{I-O} | 8-Pin DIP | | | 1 | μA | 45% RH, t = 5 s, $V_{I-O} = 3\text{ kVdc}$, $T_A = 25^\circ\text{C}$ | | 6, 16 |
| Input-Output Resistance | R_{I-O} | 8-Pin DIP SO-8 | | 10 ¹² | | Ω | $V_{I-O} = 500\text{ Vdc}$ | | 6 |
| Input-Output Capacitance | C_{I-O} | 8-Pin DIP SO-8 | | 0.6 | | pF | f = 1 MHz | | 6 |

*All typicals at $T_A = 25^\circ\text{C}$.

**The Input-Output Momentary Withstand Voltage is a dielectric voltage rating that should not be interpreted as an input-output continuous voltage rating. For the continuous voltage rating refer to the IEC/EN/DIN EN 60747-5-2 Insulation Related Characteristics Table (if applicable), your equipment level safety specification or Avago Application Note 1074 entitled "Optocoupler Input-Output Endurance Voltage," publication number 5963-2203E.

Notes:

- Derate linearly above 70°C free-air temperature at a rate of $0.8\text{ mA}/^\circ\text{C}$ (8-Pin DIP).
Derate linearly above 85°C free-air temperature at a rate of $0.5\text{ mA}/^\circ\text{C}$ (SO-8).
- Derate linearly above 70°C free-air temperature at a rate of $1.6\text{ mA}/^\circ\text{C}$ (8-Pin DIP).
Derate linearly above 85°C free-air temperature at a rate of $1.0\text{ mA}/^\circ\text{C}$ (SO-8).
- Derate linearly above 70°C free-air temperature at a rate of $0.9\text{ mW}/^\circ\text{C}$ (8-Pin DIP).
Derate linearly above 85°C free-air temperature at a rate of $1.1\text{ mW}/^\circ\text{C}$ (SO-8).
- Derate linearly above 70°C free-air temperature at a rate of $2.0\text{ mW}/^\circ\text{C}$ (8-Pin DIP).
Derate linearly above 85°C free-air temperature at a rate of $2.3\text{ mW}/^\circ\text{C}$ (SO-8).
- CURRENT TRANSFER RATIO in percent is defined as the ratio of output collector current, I_O , to the forward LED input current, I_F , times 100.
- Device considered a two-terminal device: Pins 1, 2, 3, and 4 shorted together and Pins 5, 6, 7, and 8 shorted together.
- Common mode transient immunity in a Logic High level is the maximum tolerable (positive) dV_{CM}/dt on the leading edge of the common mode pulse signal, V_{CM} , to assure that the output will remain in a Logic High state (i.e., $V_O > 2.0\text{ V}$). Common mode transient immunity in a Logic Low level is the maximum tolerable (negative) dV_{CM}/dt on the trailing edge of the common mode pulse signal, V_{CM} , to assure that the output will remain in a Logic Low state (i.e., $V_O < 0.8\text{ V}$).
- The $1.9\text{ k}\Omega$ load represents 1 TTL unit load of 1.6 mA and the $5.6\text{ mA k}\Omega$ pull-up resistor.
- The $4.1\text{ k}\Omega$ load represents 1 LSTTL unit load of 0.36 mA and $6.1\text{ k}\Omega$ pull-up resistor.
- The frequency at which the AC output voltage is 3 dB below its mid-frequency value.
- The JEDEC registration for the 6N136 specifies a minimum CTR of 15%. Avago guarantees a minimum CTR of 15%.
- See Option 020 data sheet for more information.
- Use of a $0.1\text{ }\mu\text{f}$ bypass capacitor connected between pins 5 and 8 is recommended.
- In accordance with UL 1577, each optocoupler is proof tested by applying an insulation test voltage $\geq 4500\text{ V rms}$ for 1 second (leakage detection current limit, $I_{I-O} \leq 5\text{ }\mu\text{A}$). This test is performed before the 100% Production test shown in the IEC/EN/DIN EN 60747-5-2 Insulation Related Characteristics Table, if applicable.
- In accordance with UL 1577, each optocoupler is proof tested by applying an insulation test voltage $\geq 6000\text{ V rms}$ for 1 second (leakage detection current limit, $I_{I-O} \leq 5\text{ }\mu\text{A}$). This test is performed before the 100% Production test shown in the IEC/EN/DIN EN 60747-5-2 Insulation Related Characteristics Table, if applicable.
- This rating is equally validated by an equivalent AC proof test.



Figure 1. Input current vs. forward voltage.



Figure 2. Current transfer ratio vs. temperature.



Figure 3. Current transfer ratio vs. temperature



Figure 4. Logic high output current vs. temperature.



Figure 5. Logic high output current vs. temperature



Figure 6. Thermal derating curve, dependence of safety limiting value with case temperature per IEC/EN/DIN EN 60747-5-2.

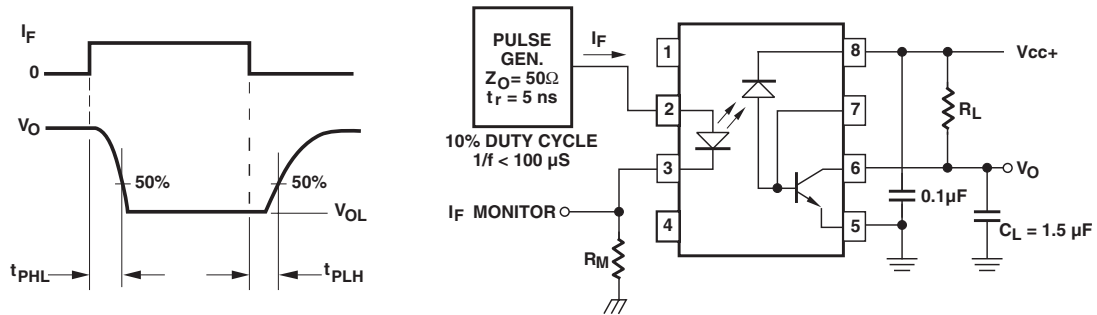

Figure 7. Switching test circuit.

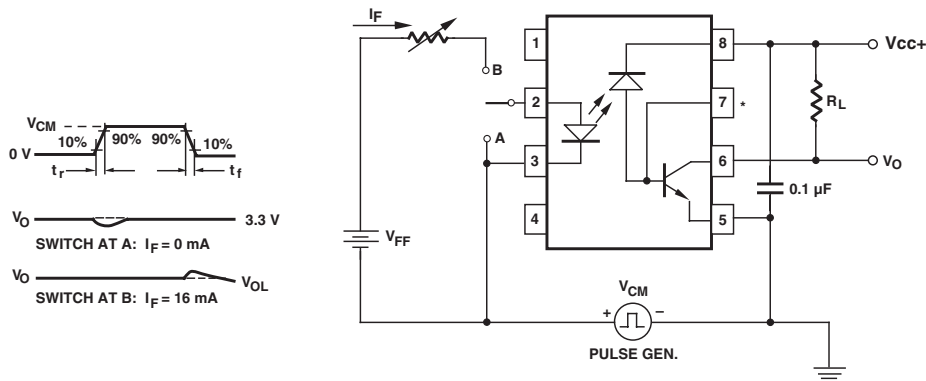

Figure 8. Test circuit for transient immunity and typical waveforms.

For product information and a complete list of distributors, please go to our web site: www.avagotech.com

Avago, Avago Technologies, and the A logo are trademarks of Avago Technologies Limited in the United States and other countries. Data subject to change. Copyright © 2008 Avago Technologies Limited. All rights reserved. Obsoletes AV01-0549EN AV02-1200EN - May 5, 2008

AVAGO
TECHNOLOGIES



Компания «ЭлектроПласт» предлагает заключение долгосрочных отношений при поставках импортных электронных компонентов на взаимовыгодных условиях!

Наши преимущества:

- Оперативные поставки широкого спектра электронных компонентов отечественного и импортного производства напрямую от производителей и с крупнейших мировых складов;
- Поставка более 17-ти миллионов наименований электронных компонентов;
- Поставка сложных, дефицитных, либо снятых с производства позиций;
- Оперативные сроки поставки под заказ (от 5 рабочих дней);
- Экспресс доставка в любую точку России;
- Техническая поддержка проекта, помощь в подборе аналогов, поставка прототипов;
- Система менеджмента качества сертифицирована по Международному стандарту ISO 9001;
- Лицензия ФСБ на осуществление работ с использованием сведений, составляющих государственную тайну;
- Поставка специализированных компонентов (Xilinx, Altera, Analog Devices, Intersil, Interpoint, Microsemi, Aeroflex, Peregrine, Syfer, Eurofarad, Texas Instrument, Miteq, Cobham, E2V, MA-COM, Hittite, Mini-Circuits, General Dynamics и др.);

Помимо этого, одним из направлений компании «ЭлектроПласт» является направление «Источники питания». Мы предлагаем Вам помощь Конструкторского отдела:

- Подбор оптимального решения, техническое обоснование при выборе компонента;
- Подбор аналогов;
- Консультации по применению компонента;
- Поставка образцов и прототипов;
- Техническая поддержка проекта;
- Защита от снятия компонента с производства.



Как с нами связаться

Телефон: 8 (812) 309 58 32 (многоканальный)

Факс: 8 (812) 320-02-42

Электронная почта: org@eplast1.ru

Адрес: 198099, г. Санкт-Петербург, ул. Калинина, дом 2, корпус 4, литера А.