



## Improved Quad SPST CMOS Analog Switches

### FEATURES

- Low On-Resistance: 45  $\Omega$
- Low Power Consumption: 1.0 mW
- Fast Switching Action— $t_{ON}$ : 120 ns
- Low Charge Injection—Q: -1 pC
- TTL/CMOS-Compatible Logic
- Single Supply Capability

### BENEFITS

- Less Signal Errors and Distortion
- Reduced Power Supply Requirements
- Faster Throughput
- Reduced Pedestal Errors
- Simple Interfacing

### APPLICATIONS

- Audio Switching
- Data Acquisition
- Sample-and-Hold Circuits
- Communication Systems
- Automatic Test Equipment
- Medical Instruments

### DESCRIPTION

The DG441B/442B are monolithic quad analog switches designed to provide high speed, low error switching of analog and audio signals. The DG441B/442B are upgrades to the original DG441/442.

Combining low on-resistance (45  $\Omega$ , typ.) with high speed ( $t_{ON}$  120 ns, typ.), the DG441B/442B are ideally suited for Data Acquisition, Communication Systems, Automatic Test Equipment, or Medical Instrumentation. Charge injection has

been minimized on the drain for use in sample-and-hold circuits.

The DG441B/442B are built using Vishay Siliconix's high-voltage silicon-gate process. An epitaxial layer prevents latchup.

When on, each switch conducts equally well in both directions and blocks input voltages to the supply levels when off.

### FUNCTIONAL BLOCK DIAGRAM AND PIN CONFIGURATION

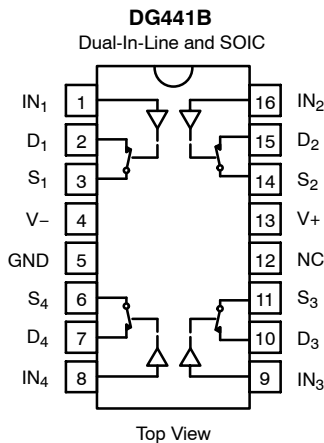

TRUTH TABLE		
Logic	DG441B	DG442B
0	ON	OFF
1	OFF	ON

Logic "0"  $\leq$  0.8 V  
Logic "1"  $\geq$  2.4 V



### ORDERING INFORMATION

Temp Range	Package	Part Number
-40 to 85°C	16-Pin Plastic DIP	DG441BDJ
		DG442BDJ
	16-Pin Narrow SOIC	DG441BDY
		DG442BDY
	16-Pin QFN 4x4 mm	DG441BDN
		DG442BDN



### ABSOLUTE MAXIMUM RATINGS

V+ to V-	44 V
GND to V-	25 V
Digital Inputs <sup>a</sup> V <sub>S</sub> , V <sub>D</sub>	(V-) -2 V to (V+) +2 V or 30 mA, whichever occurs first
Continuous Current (Any Terminal)	30 mA
Current, S or D (Pulsed 1 ms, 10% duty cycle)	100 mA
Storage Temperature	-65 to 125°C

Power Dissipation (Package) <sup>b</sup>	
16-Pin Plastic DIP <sup>c</sup>	470 mW
16-Pin Narrow Body SOIC <sup>d</sup>	900 mW
QFN-16 <sup>d</sup>	850 mW

Notes:

- Signals on S<sub>X</sub>, D<sub>X</sub>, or IN<sub>X</sub> exceeding V+ or V- will be clamped by internal diodes. Limit forward diode current to maximum current ratings.
- All leads welded or soldered to PC Board.
- Derate 6 mW/°C above 75°C
- Derate 12 mW/°C above 25°C

Stresses beyond those listed under "Absolute Maximum Ratings" may cause permanent damage to the device. These are stress ratings only, and functional operation of the device at these or any other conditions beyond those indicated in the operational sections of the specifications is not implied. Exposure to absolute maximum rating conditions for extended periods may affect device reliability.

SPECIFICATIONS <sup>a</sup> FOR DUAL SUPPLIES							
Parameter	Symbol	Test Conditions Unless Otherwise Specified V+ = 15 V, V- = -15 V, V <sub>L</sub> = 5 V, V <sub>IN</sub> = 2.4 V, 0.8 V <sup>f</sup>	Temp <sup>b</sup>	Limits -40 to 85°C			Unit
				Min <sup>d</sup>	Typ <sup>c</sup>	Max <sup>d</sup>	
<b>Analog Switch</b>							
Analog Signal Range <sup>e</sup>	V <sub>ANALOG</sub>		Full	-15		15	V
Drain-Source On-Resistance	r <sub>DS(on)</sub>	I <sub>S</sub> = 1 mA, V <sub>D</sub> = ∓10 V	Room Full		45	80 95	Ω
On-Resistance Match Between Channels <sup>e</sup>	Δr <sub>DS(on)</sub>	I <sub>S</sub> = 1 mA, V <sub>D</sub> = ±10 V	Room Full		2	4 5	
Switch Off Leakage Current	I <sub>S(off)</sub>	V <sub>D</sub> = ±14 V, V <sub>S</sub> = ∓14 V	Room Full	-0.5 -5	±0.01	0.5 5	nA
	I <sub>D(off)</sub>		Room Full	-0.5 -5	±0.01	0.5 5	
Channel On Leakage Current	I <sub>D(on)</sub>	V <sub>S</sub> = V <sub>D</sub> = ±14 V	Room Full	-0.5 -10	∓0.02	0.5 10	
<b>Digital Control</b>							
Input Voltage Low	V <sub>INL</sub>		Full			0.8	V
Input Voltage High	V <sub>INH</sub>		Full	2.4			
Input Current V <sub>IN</sub> Low	I <sub>INL</sub>	V <sub>IN</sub> under test = 0.8 V, All Other = 2.4 V	Full	-1	-0.01	1	μA
Input Current V <sub>IN</sub> High	I <sub>INH</sub>	V <sub>IN</sub> under test = 2.4 V, All Other = 0.8 V	Full	-1	0.01	1	
<b>Dynamic Characteristics</b>							
Turn-On Time	t <sub>ON</sub>	R <sub>L</sub> = 1 kΩ, C <sub>L</sub> = 35 pF V <sub>S</sub> = 10 V, See Figure 2	Room			120	ns
Turn-Off Time	t <sub>OFF</sub>		Room			65	
Charge Injection <sup>e</sup>	Q	C <sub>L</sub> = 1 nF, V <sub>S</sub> = 0 V, V <sub>gen</sub> = 0 V, R <sub>gen</sub> = 0 Ω	Room		-1		pC
Off Isolation <sup>e</sup>	OIRR	R <sub>L</sub> = 50 Ω, C <sub>L</sub> = 15 pF, V <sub>S</sub> = 1 V <sub>RMS</sub> f = 100 kHz	Room			90	dB
Crosstalk (Channel-to-Channel)	X <sub>TALK</sub>		Room			95	
Source Off Capacitance <sup>e</sup>	C <sub>S(off)</sub>	f = 1 MHz	Room			4	pF
Drain Off Capacitance <sup>e</sup>	C <sub>D(off)</sub>		Room			4	
Channel On Capacitance <sup>e</sup>	C <sub>D(on)</sub>		V <sub>S</sub> = V <sub>D</sub> = 0 V, f = 1 MHz	Room			
<b>Power Supplies</b>							
Positive Supply Current	I+	V+ = 16.5 V, V- = -16.5 V V <sub>IN</sub> = 0 or 5 V	Room Full			1 5	μA
Negative Supply Current	I-		Room Full	-1 -5			

**SPECIFICATIONS<sup>a</sup> FOR SINGLE SUPPLY**

Parameter	Symbol	Test Conditions Otherwise Unless Specified $V_+ = 12\text{ V}, V_- = 0\text{ V}, V_{IN} = 2.4\text{ V}, 0.8\text{ V}^f$	Temp <sup>b</sup>	Limits -40 to 85°C			Unit
				Min <sup>d</sup>	Typ <sup>c</sup>	Max <sup>d</sup>	
<b>Analog Switch</b>							
Analog Signal Range <sup>e</sup>	$V_{ANALOG}$		Full	0		12	V
Drain-Source On-Resistance	$r_{DS(on)}$	$I_S = 1\text{ mA}, V_D = 3\text{ V}, 8\text{ V}$	Room Full		90	160 200	$\Omega$
<b>Dynamic Characteristics</b>							
Turn-On Time	$t_{ON}$	$R_L = 1\text{ k}\Omega, C_L = 35\text{ pF}$ $V_S = 8\text{ V}$ , See Figure 2	Room		120	300	ns
Turn-Off Time	$t_{OFF}$		Room		60	200	
Charge Injection	Q	$C_L = 1\text{ nF}, V_{gen} = 6\text{ V}, R_{gen} = 0\ \Omega$	Room		4		pC
<b>Power Supplies</b>							
Positive Supply Current	$I_+$	$V_{IN} = 0\text{ or }5\text{ V}$	Room Full			1 5	$\mu\text{A}$
Negative Supply Current	$I_-$		Room Full		-1 -5		

Notes:

- a. Refer to PROCESS OPTION FLOWCHART.
- b. Room = 25°C, Full = as determined by the operating temperature suffix.
- c. Typical values are for DESIGN AID ONLY, not guaranteed nor subject to production testing.
- d. The algebraic convention whereby the most negative value is a minimum and the most positive a maximum, is used in this data sheet.
- e. Guaranteed by design, not subject to production test.
- f.  $V_{IN}$  = input voltage to perform proper function.

**SCHEMATIC DIAGRAM (TYPICAL CHANNEL)**

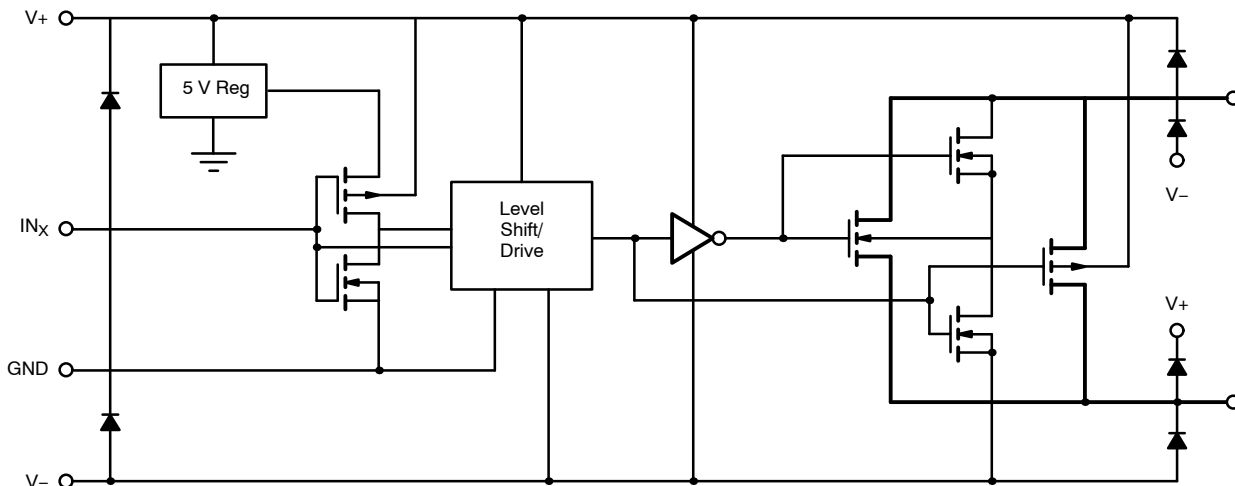
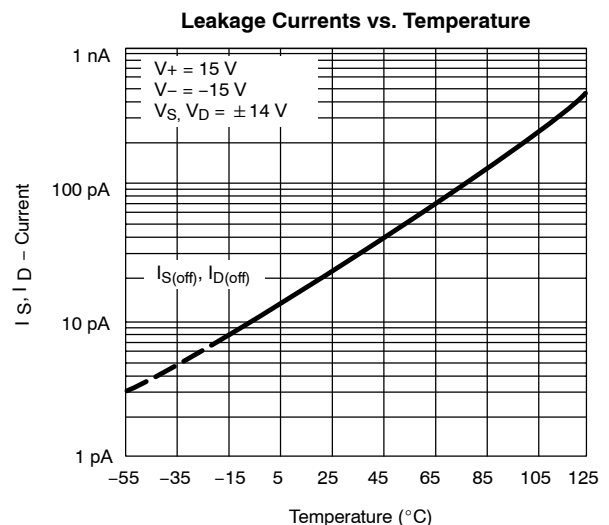
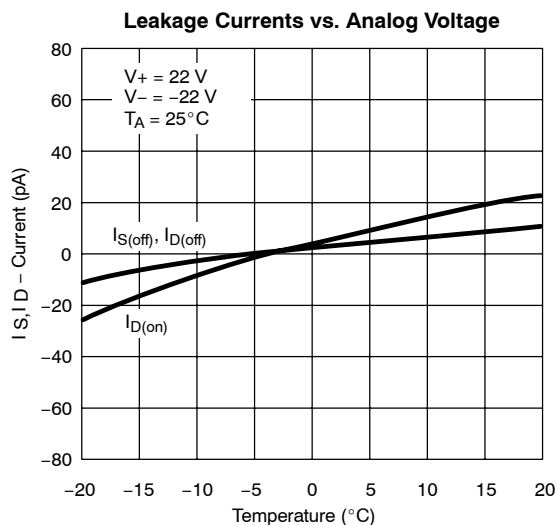
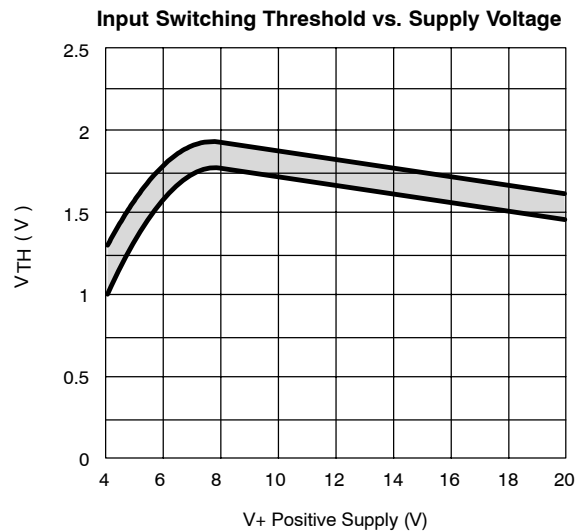
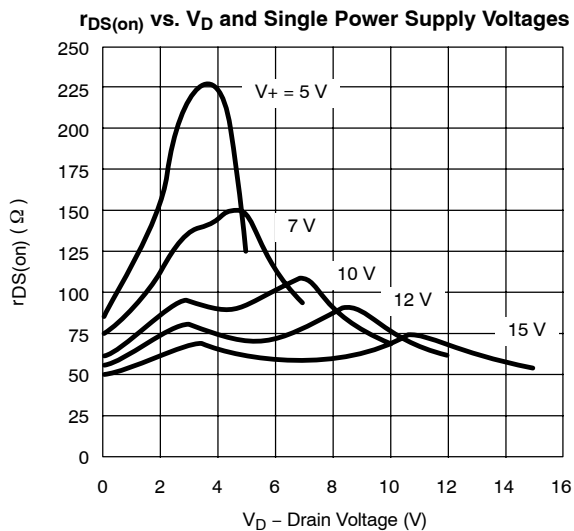
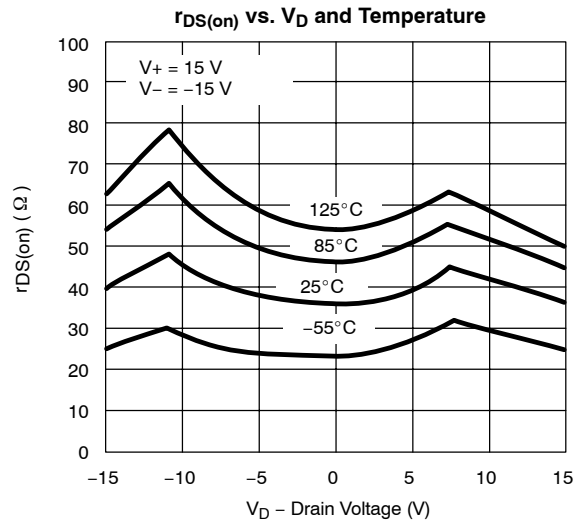
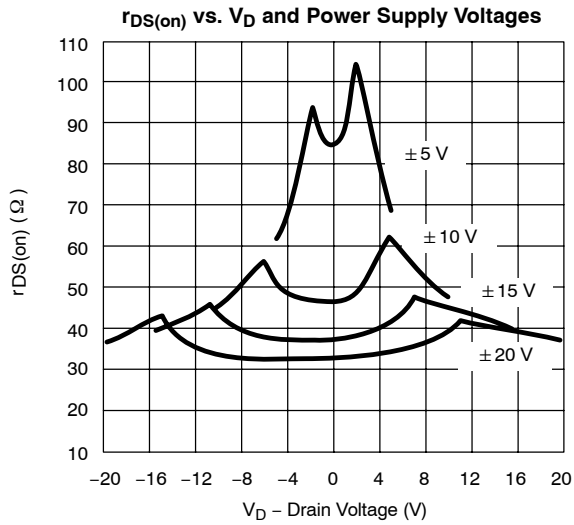

FIGURE 1.

**TYPICAL CHARACTERISTICS (25°C UNLESS NOTED)**





**TYPICAL CHARACTERISTICS (25°C UNLESS NOTED)**

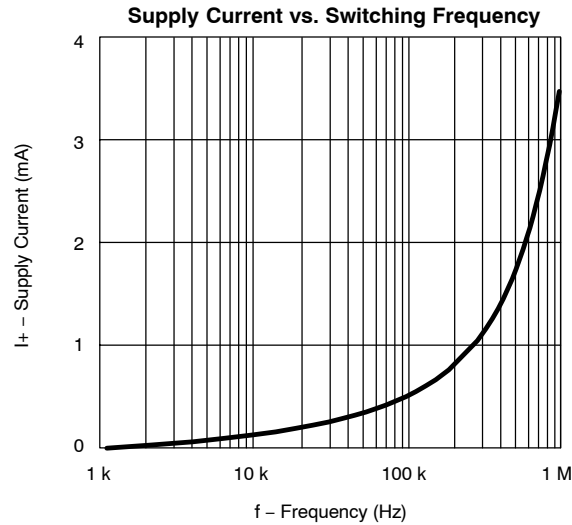
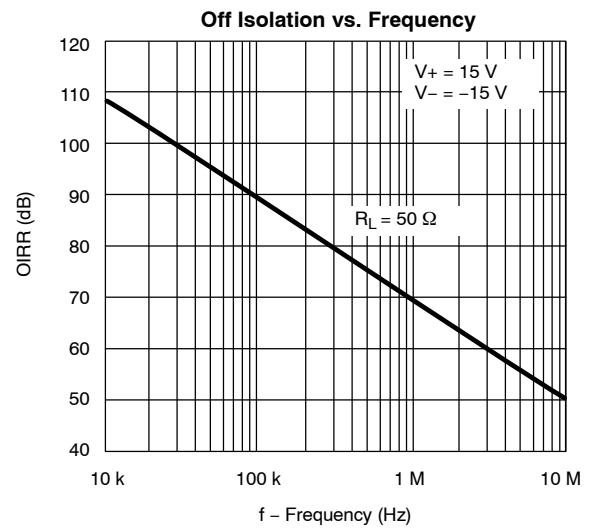
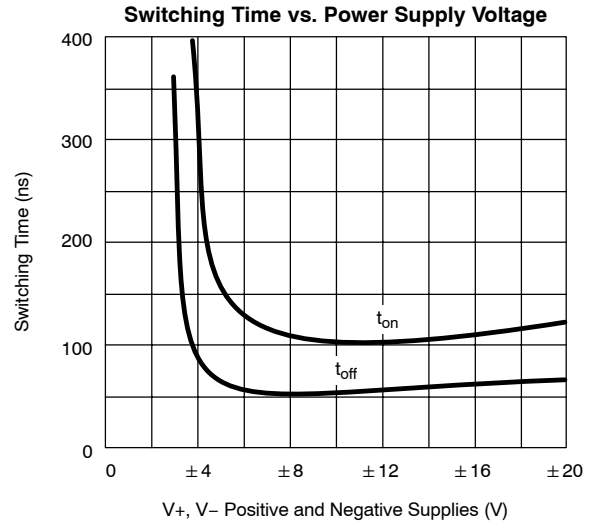

TEST CIRCUITS



$C_L$  (includes fixture and stray capacitance)



Note: Logic input waveform is inverted for DG442.

FIGURE 2. Switching Time

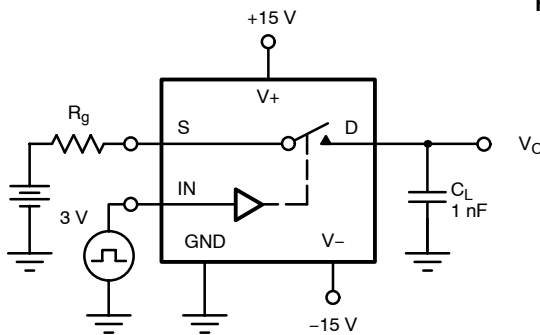

FIGURE 3. Charge Injection

$C = 1\text{ mF}$  tantalum in parallel with  $0.01\text{ mF}$  ceramic



$$X_{\text{TALK Isolation}} = 20 \log \left| \frac{V_S}{V_O} \right|$$

$C = \text{RF bypass}$

FIGURE 4. Crosstalk



$$\text{Off Isolation} = 20 \log \left| \frac{V_S}{V_O} \right|$$

FIGURE 5. Off Isolation



FIGURE 6. Source/Drain Capacitances

APPLICATIONS

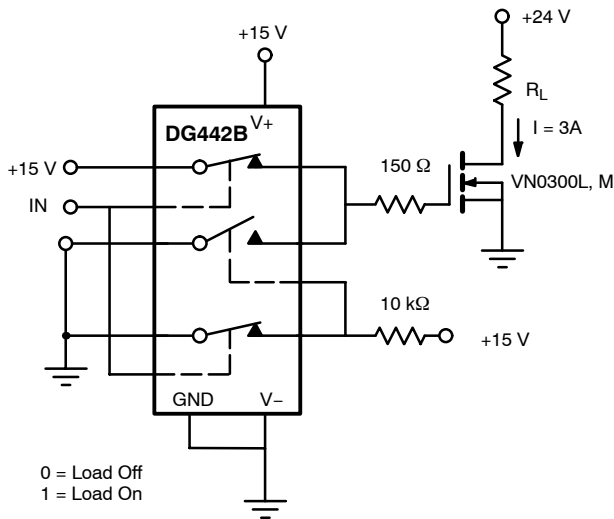

FIGURE 7. Power MOSFET Driver



FIGURE 8. Open Loop Sample-and-Hold

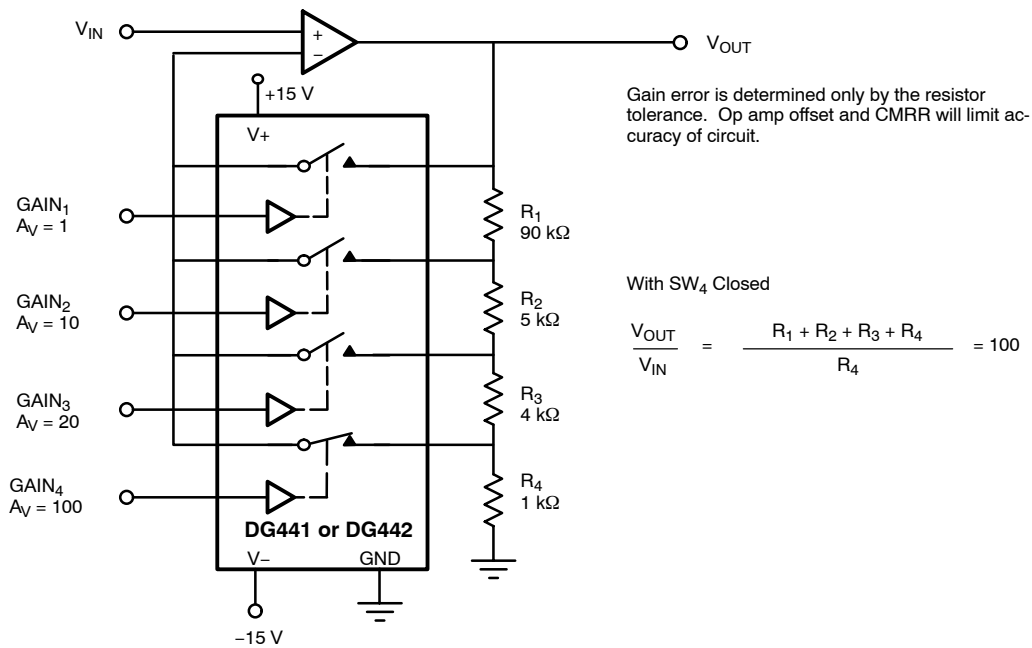

FIGURE 9. Precision-Weighted Resistor Programmable-Gain Amplifier



Компания «ЭлектроПласт» предлагает заключение долгосрочных отношений при поставках импортных электронных компонентов на взаимовыгодных условиях!

Наши преимущества:

- Оперативные поставки широкого спектра электронных компонентов отечественного и импортного производства напрямую от производителей и с крупнейших мировых складов;
- Поставка более 17-ти миллионов наименований электронных компонентов;
- Поставка сложных, дефицитных, либо снятых с производства позиций;
- Оперативные сроки поставки под заказ (от 5 рабочих дней);
- Экспресс доставка в любую точку России;
- Техническая поддержка проекта, помощь в подборе аналогов, поставка прототипов;
- Система менеджмента качества сертифицирована по Международному стандарту ISO 9001;
- Лицензия ФСБ на осуществление работ с использованием сведений, составляющих государственную тайну;
- Поставка специализированных компонентов (Xilinx, Altera, Analog Devices, Intersil, Interpoint, Microsemi, Aeroflex, Peregrine, Syfer, Eurofarad, Texas Instrument, Miteq, Cobham, E2V, MA-COM, Hittite, Mini-Circuits, General Dynamics и др.);

Помимо этого, одним из направлений компании «ЭлектроПласт» является направление «Источники питания». Мы предлагаем Вам помощь Конструкторского отдела:

- Подбор оптимального решения, техническое обоснование при выборе компонента;
- Подбор аналогов;
- Консультации по применению компонента;
- Поставка образцов и прототипов;
- Техническая поддержка проекта;
- Защита от снятия компонента с производства.



#### Как с нами связаться

**Телефон:** 8 (812) 309 58 32 (многоканальный)

**Факс:** 8 (812) 320-02-42

**Электронная почта:** [org@eplast1.ru](mailto:org@eplast1.ru)

**Адрес:** 198099, г. Санкт-Петербург, ул. Калинина, дом 2, корпус 4, литера А.