

LOC	DIST	REVISIONS			
P	LTN	DESCRIPTION	DATE	DWN	APVD
B1		REVISED PER ECO-11-004835	11MAR2011	RK	HMR
C		REVISED PER ECO-11-020849	17JAN2012	CJV	PAR
C1		REVISED PER ECO-13-003678	05APR2013	CJV	PAR
D		REVISED PER ECO-15-017922	04FEB2016	AP	PR

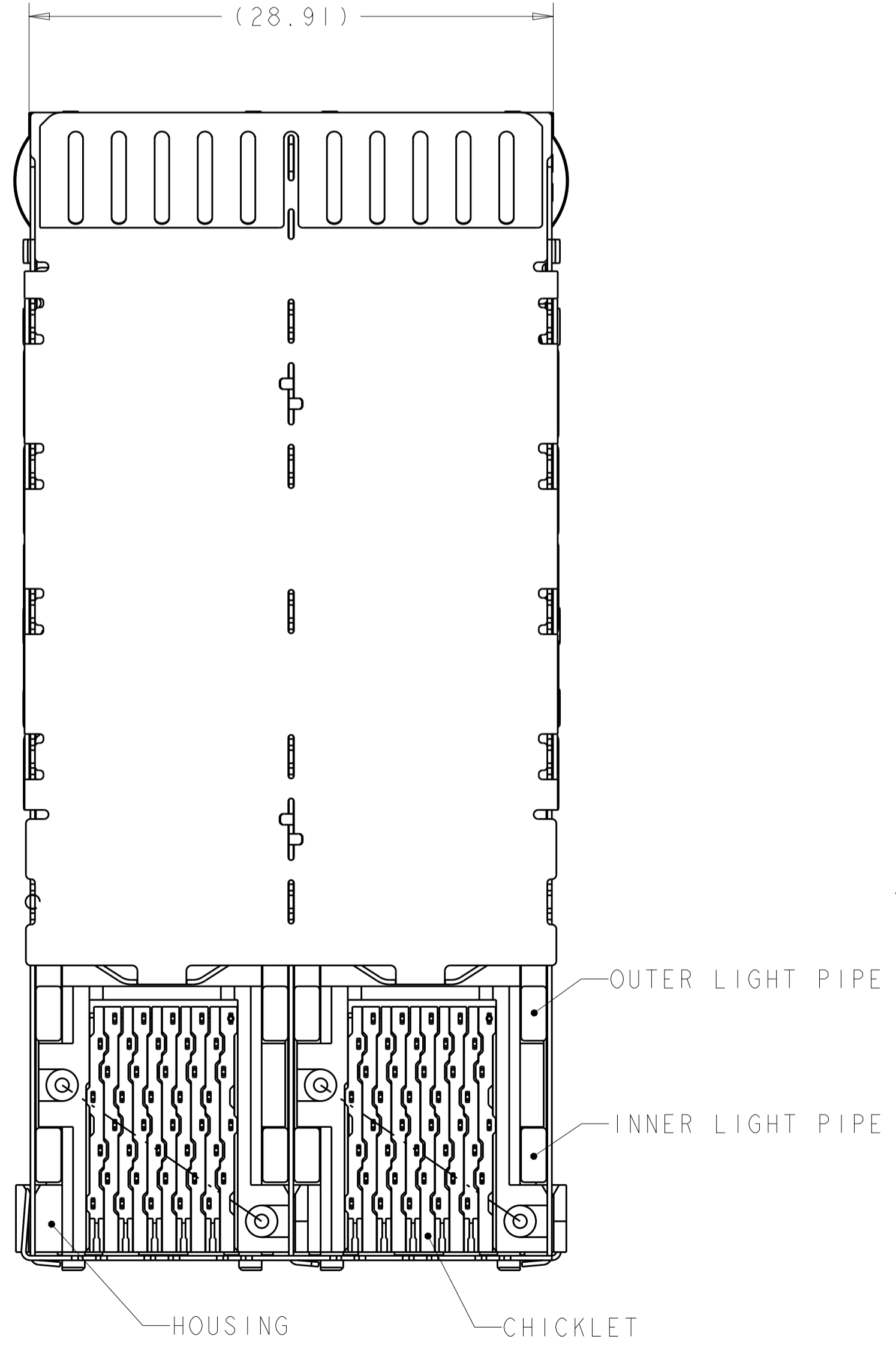
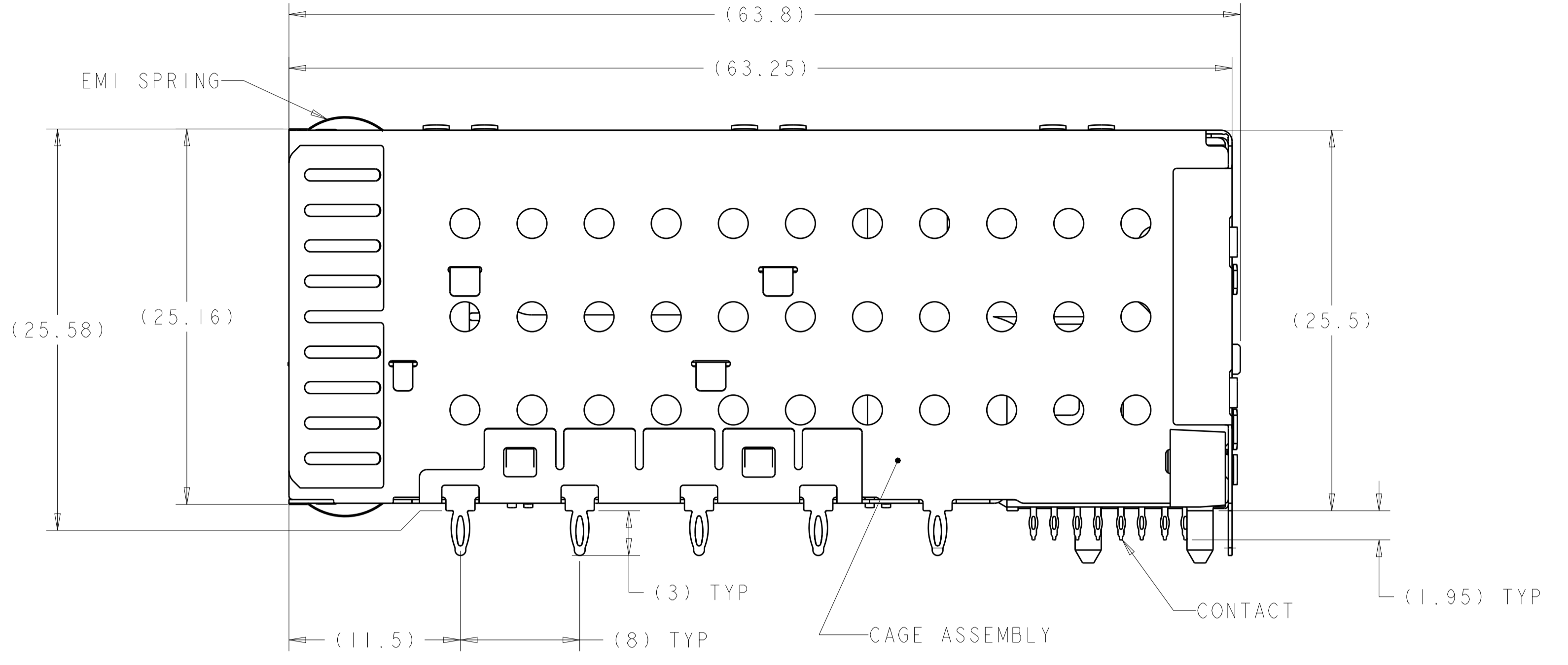
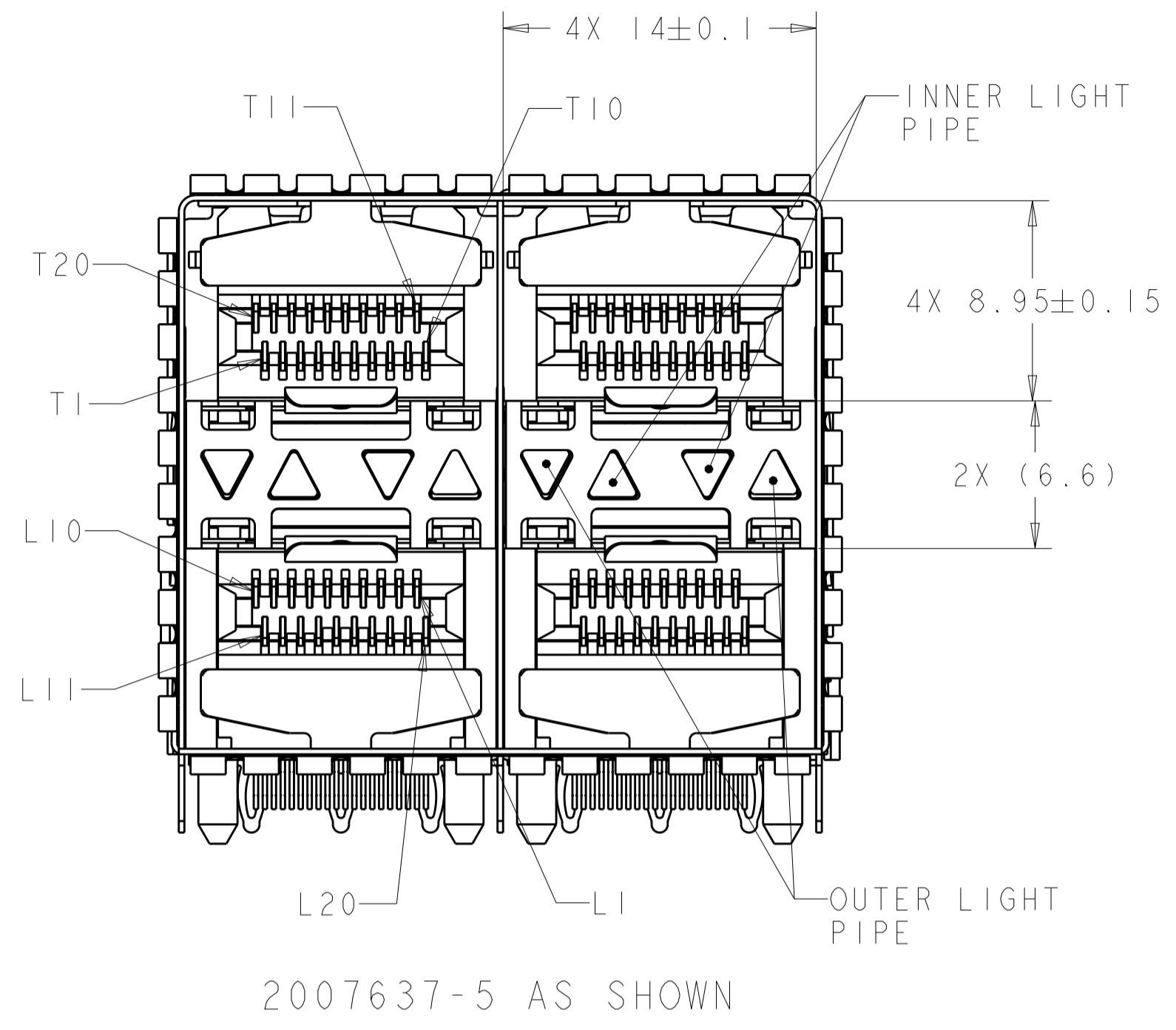

- 1 MATERIALS:  
 CAGE ASSEMBLY- NICKEL SILVER ALLOY PER ASTM B 122.  
 EMI SPRING- COPPER ALLOY.  
 HOUSING- BLACK LCP, UL 94V-0 RATED.  
 CHICKLET- BLACK LCP, UL 94V-0 RATED.  
 LIGHT PIPE- POLYCARBONATE, CLEAR.  
 INSERT - LCP, BLACK, UL 94V-0.  
 CONTACT- COPPER ALLOY.
- 2 DATUM AND BASIC DIMENSIONS ESTABLISHED BY CUSTOMER.
- 3. MINIMUM PCB THICKNESS OF 1.5.
- 4 CONTACT FINISH- CONFORMS TO THE REQUIREMENTS OF TE CONNECTIVITY PRODUCT SPECIFICATION 108-2331, BASED ON EIA/ECA-364-1000.01A, (CONTROLLED ENVIRONMENT APPLICATIONS) ON MATING INTERFACE, TIN-LEAD ON NEEDLE EYE.
- 5 CONTACT FINISH- CONFORMS TO THE REQUIREMENTS OF TE CONNECTIVITY PRODUCT SPECIFICATION 108-2331, BASED ON EIA/ECA-364-1000.01A, (CONTROLLED ENVIRONMENT APPLICATIONS) ON MATING INTERFACE, TIN ON NEEDLE EYE.
- 6 FOR HOLE SIZE AND PLATINGS, SEE APPLICATION SPEC 114-13219.
- 7 THE ENTIRE AREA OF THE CONNECTOR FOOTPRINT, INDICATED BY THE DASHED LINE, TO BE CONSIDERED THE KEEPOUT AREA FOR COMPONENTS AND SIGNAL TRACES, TOP SIDE ONLY. TOP SIDE TRACES ALLOWED WITHIN CONNECTOR HOLE PATTERN.
- 8 LIGHT PIPE PAD LAYOUT IS FOR 0805 LOW PROFILE LED PACKAGE WITH A HEIGHT OF 0.8mm.
- 9 EMI SPRING FINISH: 0.8µm MINIMUM MATTE TIN OVER 0.8µm MINIMUM NICKEL, NONPLATED EDGES PERMISSIBLE.
- 10 ADDITIONAL COMPONENT LOCATED WITHIN LATCH PLATE FOR EMI SUPPRESSION.

ENHANCED EMI	FINISH	DESCRIPTION	PART NUMBER
YES 10	5	NO LIGHT PIPES	1-2007637-8
		OUTER 2 LIGHT PIPES	1-2007637-7
		INNER 2 LIGHT PIPES	1-2007637-6
NO	5	4 LIGHT PIPES	1-2007637-5
		NO LIGHT PIPES	2007637-8
		OUTER 2 LIGHT PIPES	2007637-7
SUPERSEDED	NO	INNER 2 LIGHT PIPES	2007637-6
		4 LIGHT PIPES	2007637-5
		NO LIGHT PIPES	2007637-4
ENHANCED EMI	FINISH	OUTER 2 LIGHT PIPES	2007637-3
		INNER 2 LIGHT PIPES	2007637-2
		4 LIGHT PIPES	2007637-1

THIS DRAWING IS A CONTROLLED DOCUMENT. DIMENSIONING AND TOLERANCING PER ASME Y14.5M-2009.

DIMENSIONS: mm

TOLERANCES UNLESS OTHERWISE SPECIFIED:  
 0 PLC ±0.10  
 1 PLC ±0.10  
 2 PLC ±0.10  
 3 PLC ±0.10  
 4 PLC ±0.10  
 ANGLES ±°

MATERIAL: 1

FINISH: 4 5 9

DWN: M. SHIRK 23JAN2008  
 CHK: D. SZCZESNY 23JAN2008  
 APVD: D. SZCZESNY 23JAN2008

NAME: CAGE AND PT CONNECTOR ASSEMBLY, WITH EMI SPRINGS, PRESS FIT, 2X2, STACKED SFP+

PRODUCT SPEC: 108-2331  
 APPLICATION SPEC: 114-13219

SIZE: A1  
 CAGE CODE: 00779  
 DRAWING NO: 2007637

RESTRICTED TO: -

CUSTOMER DRAWING SCALE: 4:1 SHEET 1 OF 4 REV D

LOC		DIST		REVISIONS			
P	LTN	DESCRIPTION	DATE	DMN	APVD		
GP	00	- SEE SHEET 1	-	-	-		

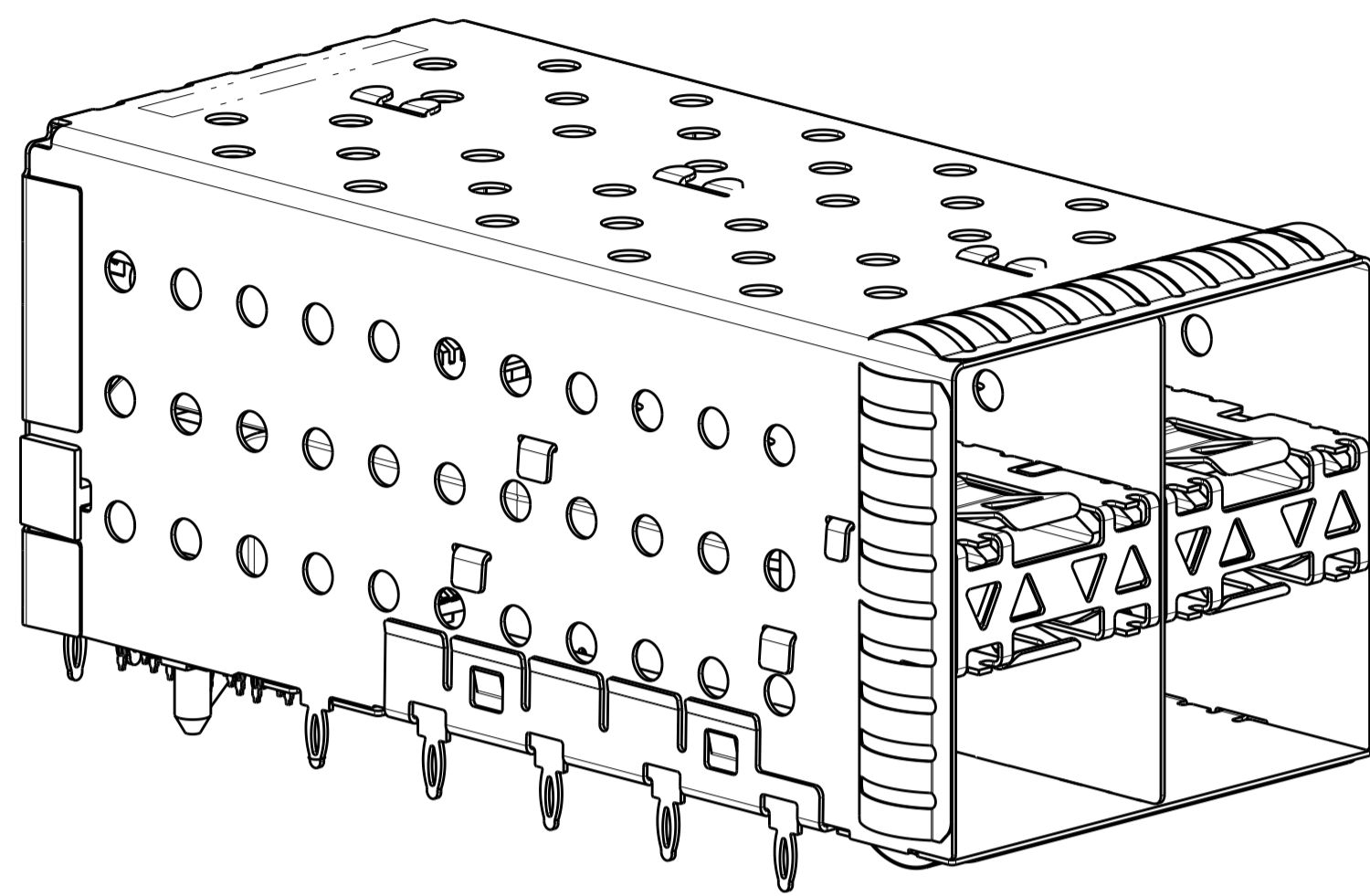

2007637-5 AND 1-2007637-5  
 SCALE 3:1

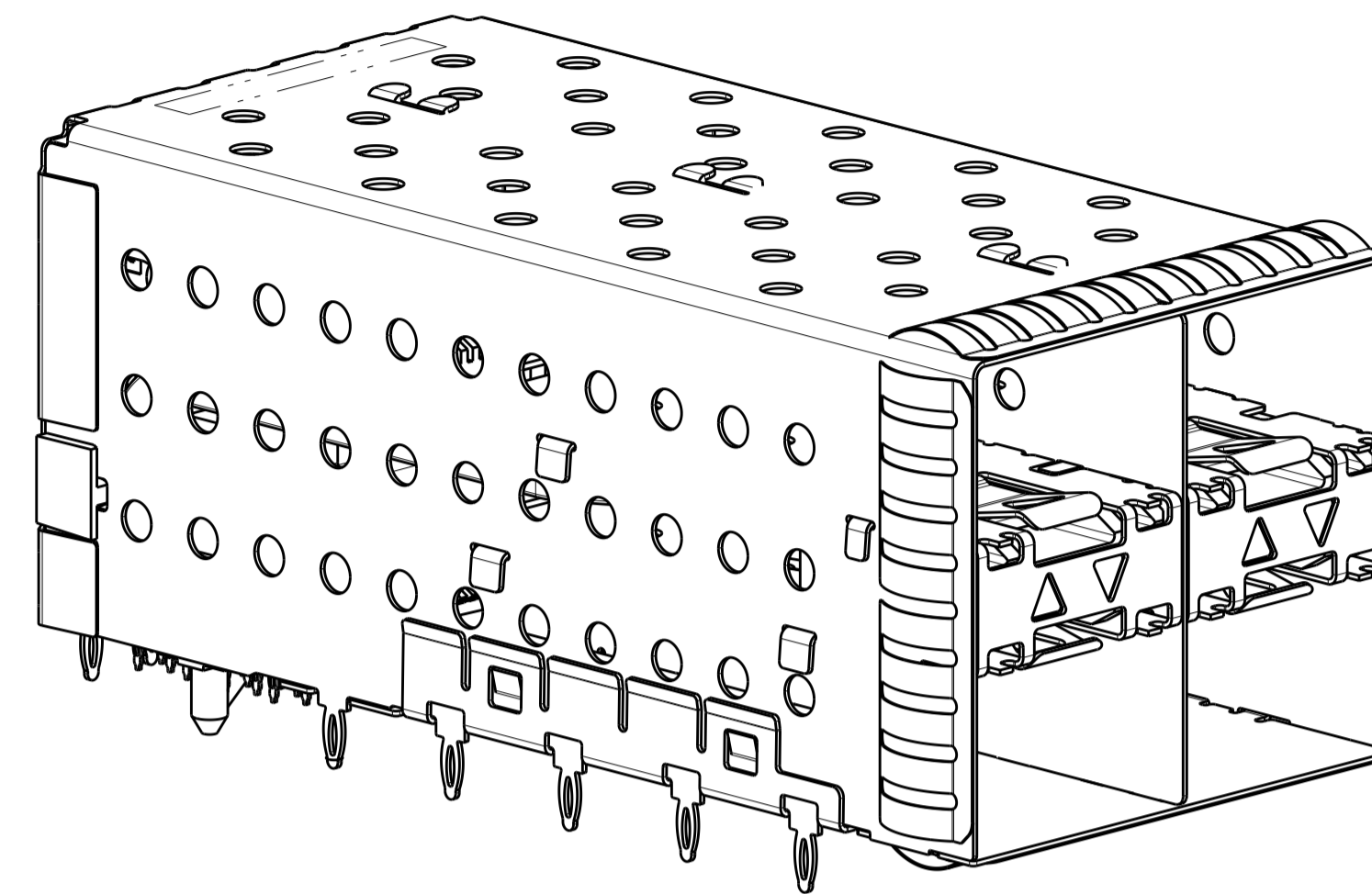

2007637-6 AND 1-2007637-6  
 SCALE 3:1

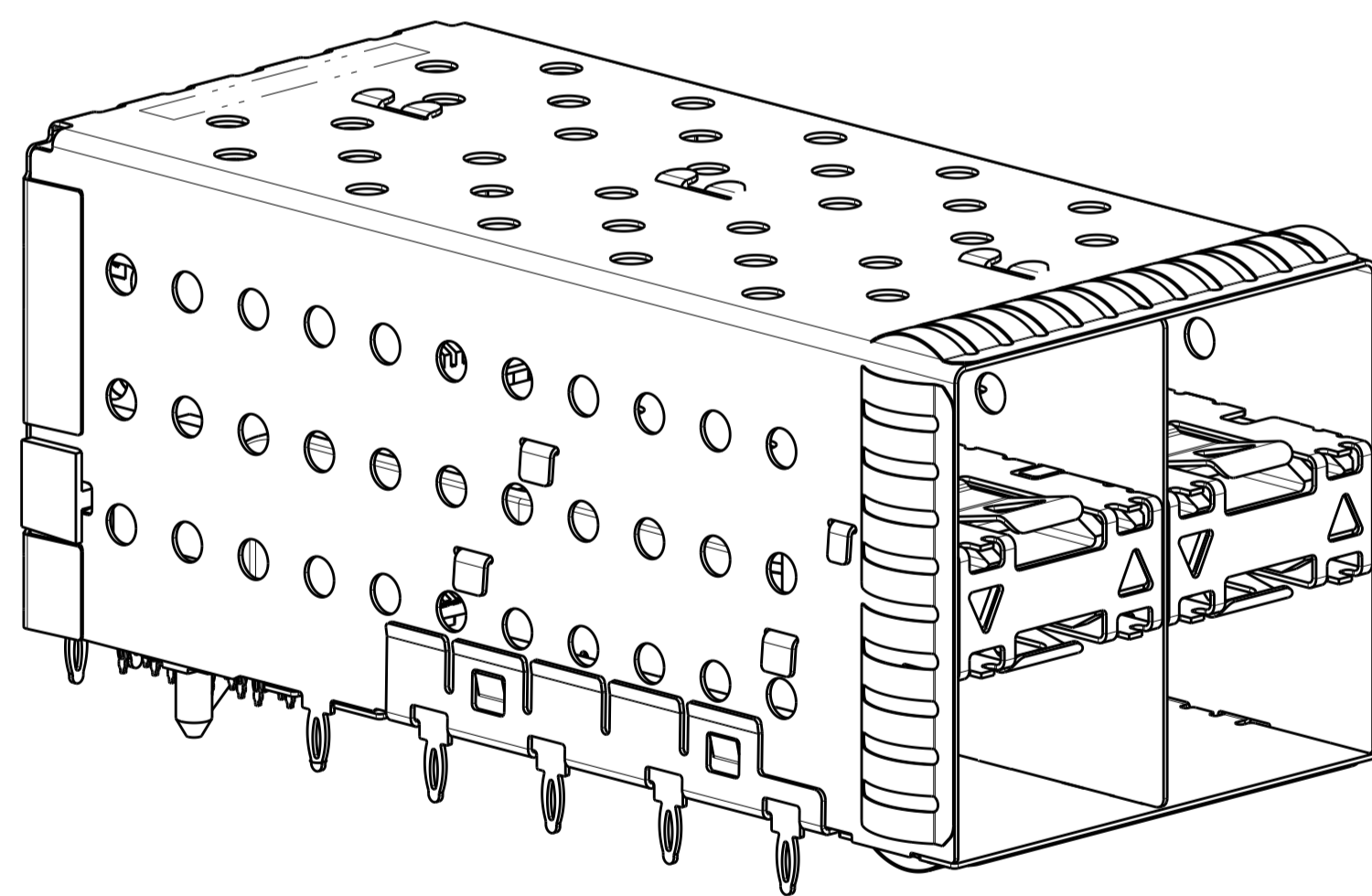

2007637-7 AND 1-2007637-7  
 SCALE 3:1

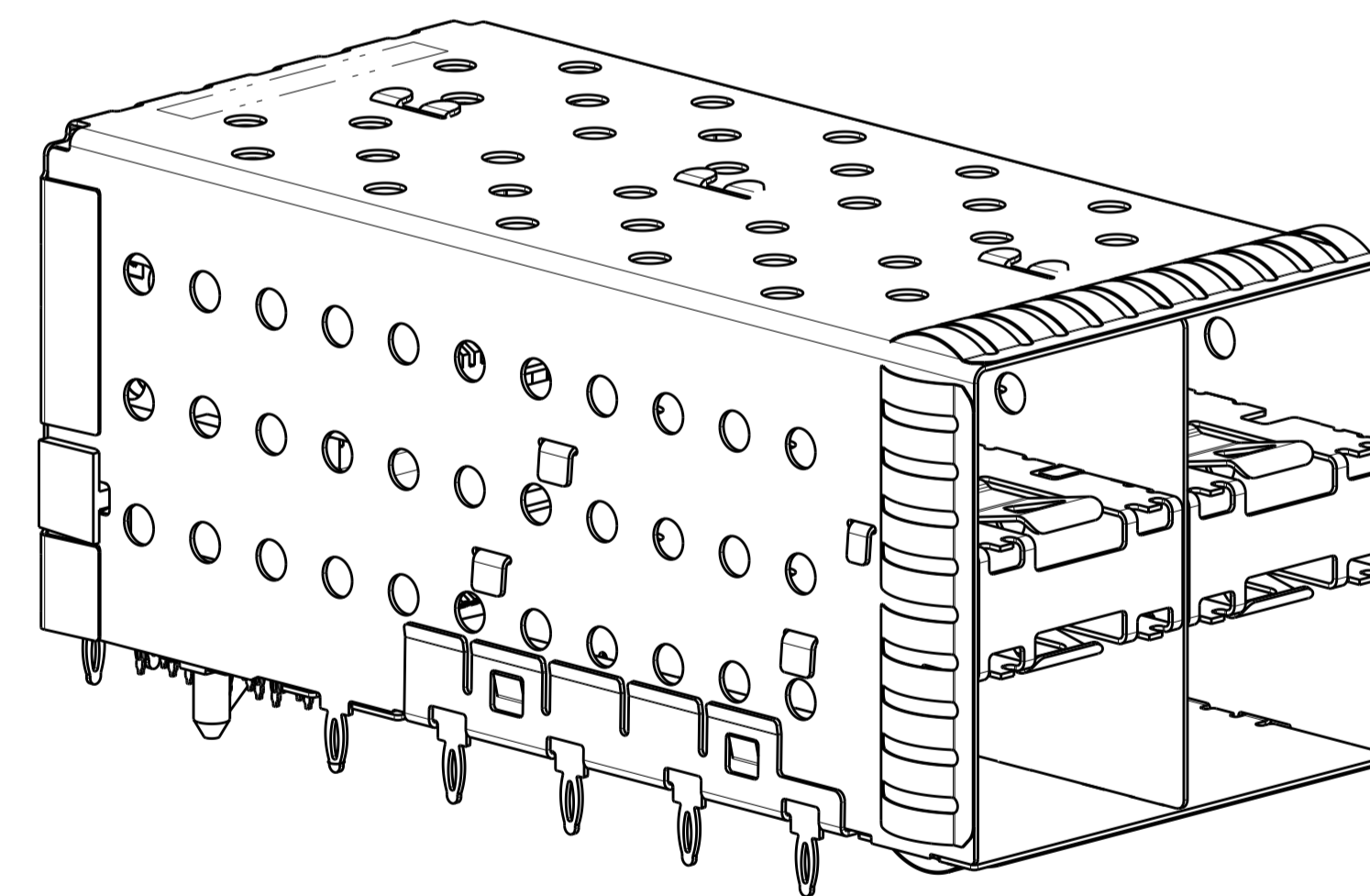

2007637-8 AND 1-2007637-8  
 SCALE 3:1

THIS DRAWING IS A CONTROLLED DOCUMENT. DIMENSIONING AND TOLERANCING PER ASME Y14.5M-2009.		DMN: M. SHIRK 23JAN2008	 TE Connectivity
DIMENSIONS: mm		CHK: D. SZCZESNY 23JAN2008	
DIMENSIONS: mm TOLERANCES UNLESS OTHERWISE SPECIFIED: 0 PLC ±0.10 1 PLC ±0.10 2 PLC ±0.10 3 PLC ±0.10 4 PLC ±0.10 ANGLES ±°		APVD: D. SZCZESNY 23JAN2008	NAME: CAGE AND PT CONNECTOR ASSEMBLY, WITH EMI SPRINGS, PRESS FIT, 2X2, STACKED SFP+
MATERIAL: FINISH:		PRODUCT SPEC: 108-2331	SIZE: CAGE CODE DRAWING NO: A100779C=2007637
		APPLICATION SPEC: 114-13219	RESTRICTED TO: -
		WEIGHT: -	CUSTOMER DRAWING
		SCALE: 4:1	SHEET 2 OF 4 REV D

LOC		DIST		REVISONS			
GP	00	P	LTN	DESCRIPTION	DATE	DMN	APVD
				SEE SHEET 1			

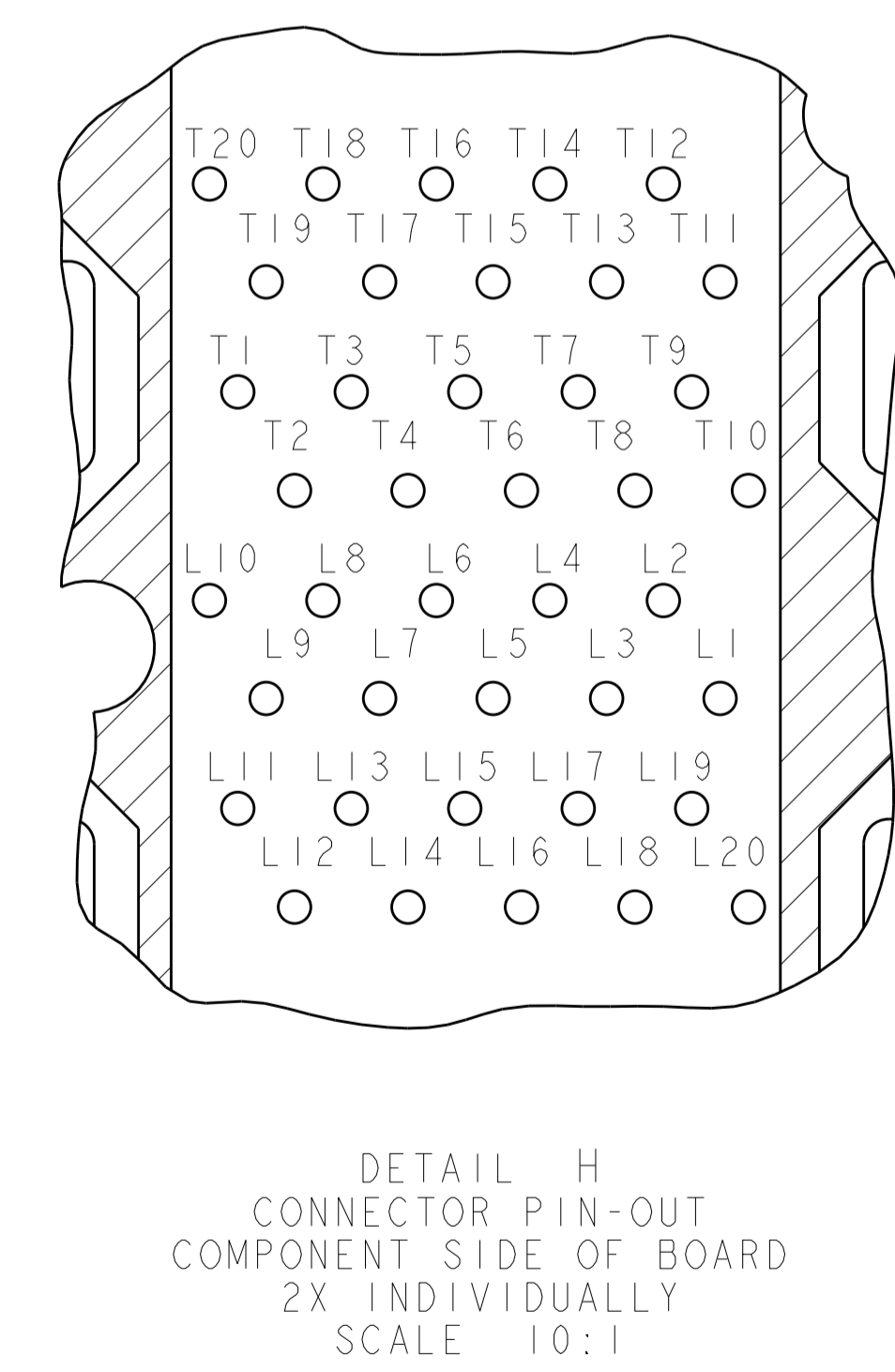
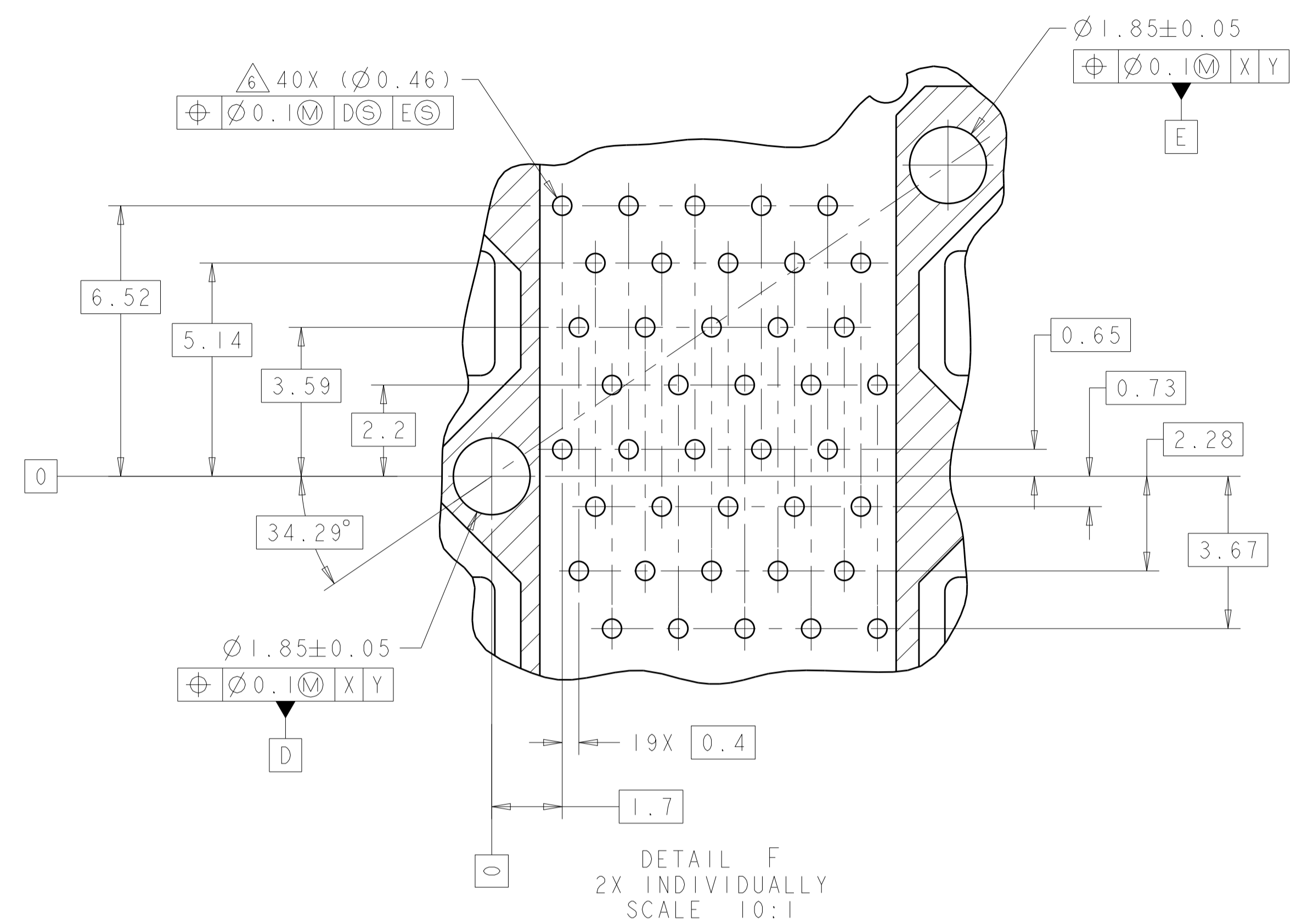
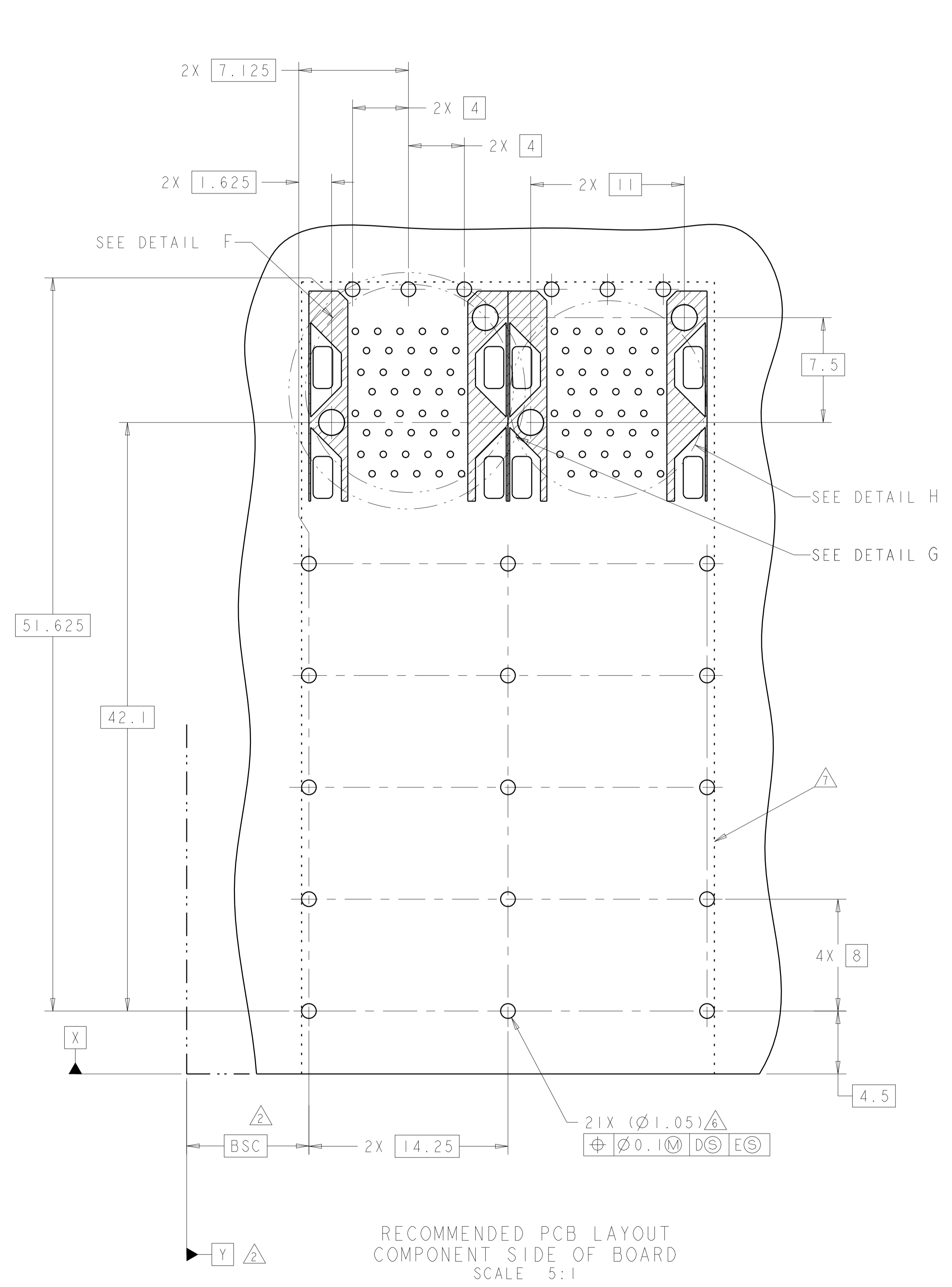

THIS DRAWING IS A CONTROLLED DOCUMENT. DIMENSIONING AND TOLERANCING PER ASME Y14.5M-2009.		DMN: M. SHIRK 23JAN2008	TE Connectivity NAME: CAGE AND PT CONNECTOR ASSEMBLY, WITH EMI SPRINGS, PRESS FIT, 2X2, STACKED SFP+
DIMENSIONS: mm		CHK: D. SZCZESNY 23JAN2008	
TOLERANCES UNLESS OTHERWISE SPECIFIED:		APVD: D. SZCZESNY 23JAN2008	PRODUCT SPEC: 108-2331
0 PLC ±0.10	1 PLC ±0.10	APPLICATION SPEC: 114-13219	SIZE: A1
2 PLC ±0.10	3 PLC ±0.10	WEIGHT: -	CAGE CODE: 100779
4 PLC ±0.10	ANGLES ±°	CUSTOMER DRAWING	SCALE: 4:1
MATERIAL FINISH		SHEET 3 OF 4	
		REV D	

LOC	DIST	REV	DATE	BY	APPV
GP	00				
REVISIONS			DESCRIPTION	DATE	BY
			SEE SHEET 1		

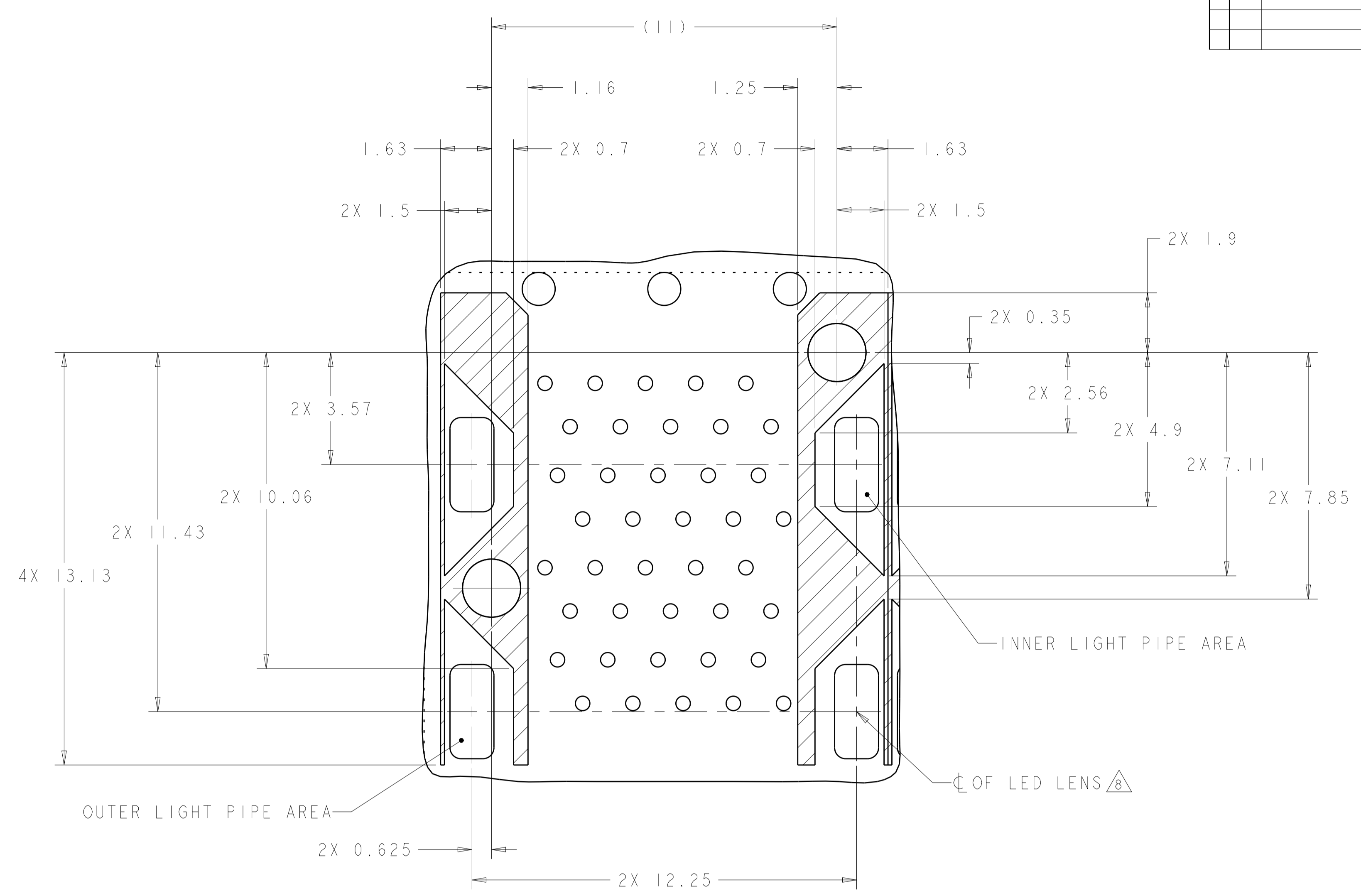

DETAIL G  
 CONNECTOR HOUSING  
 KEEPOUT ZONE  
 2X INDIVIDUALLY  
 SCALE 10:1

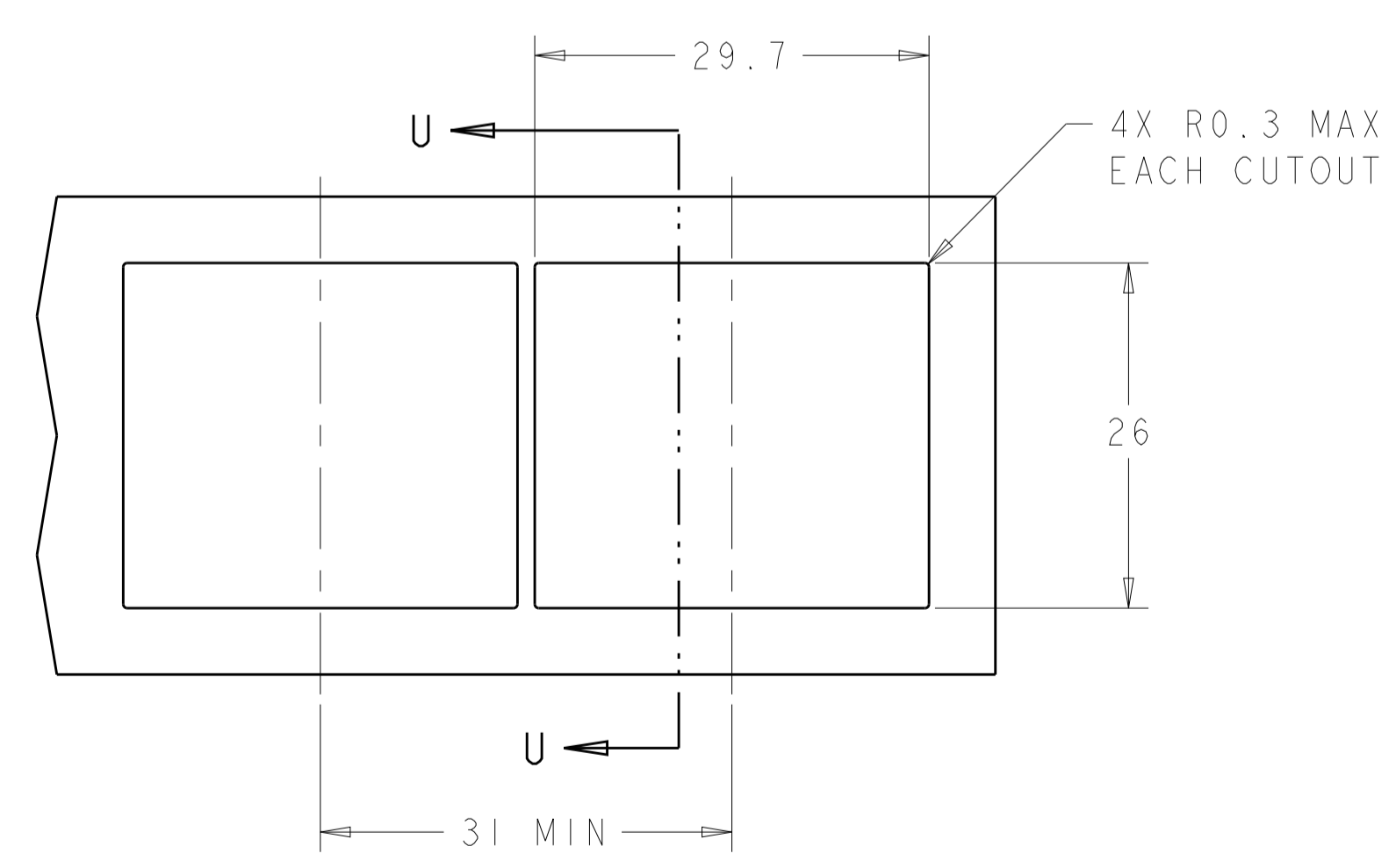

RECOMMENDED PANEL CUTOUT  
 AND PC BOARD, PANEL POSITION  
 SCALE 2:1

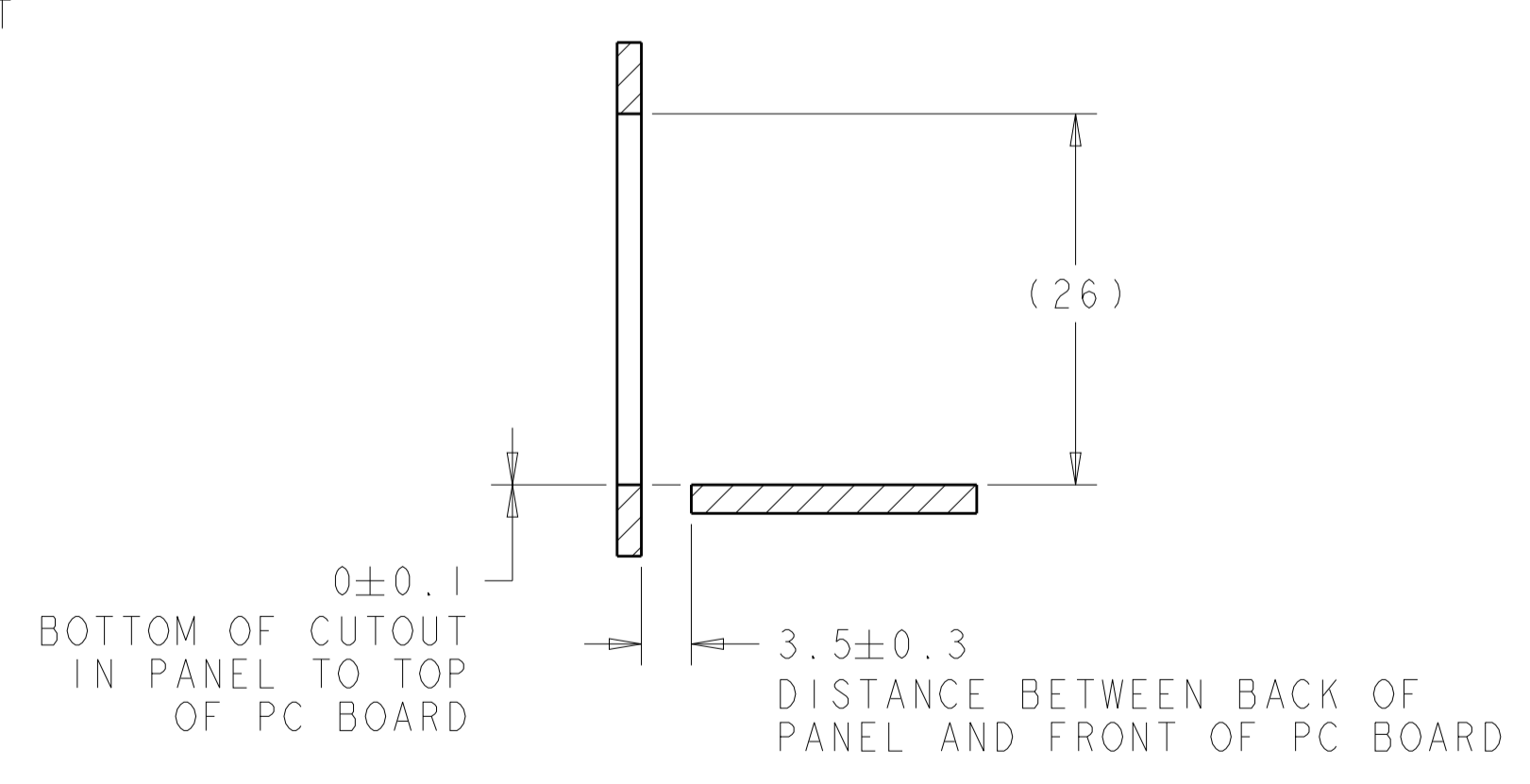

SECTION U-U

THIS DRAWING IS A CONTROLLED DOCUMENT. DIMENSIONING AND TOLERANCING PER ASME Y14.5M-2009		OWN: M. SHIRK 23JAN2008 CHK: D. SZCZESNY 23JAN2008 APPV: D. SZCZESNY 23JAN2008	TE Connectivity NAME: CAGE AND PT CONNECTOR ASSEMBLY, WITH EMI SPRINGS, PRESS FIT, 2X2, STACKED SFP+
DIMENSIONS: mm	TOLERANCES UNLESS OTHERWISE SPECIFIED:	PRODUCT SPEC: 108-2331 APPLICATION SPEC: 114-13219	
0 PLC ±0.10 1 PLC ±0.10 2 PLC ±0.10 3 PLC ±0.10 4 PLC ±0.10 ANGLES ±°	FINISH	SIZE: A100779 CAGE CODE: C=2007637 DRAWING NO: 2007637	RESTRICTED TO: -
MATERIAL	FINISH	WEIGHT	CUSTOMER DRAWING
		SCALE: 4:1	SHEET 4 OF 4 REV D



Компания «ЭлектроПласт» предлагает заключение долгосрочных отношений при поставках импортных электронных компонентов на взаимовыгодных условиях!

Наши преимущества:

- Оперативные поставки широкого спектра электронных компонентов отечественного и импортного производства напрямую от производителей и с крупнейших мировых складов;
- Поставка более 17-ти миллионов наименований электронных компонентов;
- Поставка сложных, дефицитных, либо снятых с производства позиций;
- Оперативные сроки поставки под заказ (от 5 рабочих дней);
- Экспресс доставка в любую точку России;
- Техническая поддержка проекта, помощь в подборе аналогов, поставка прототипов;
- Система менеджмента качества сертифицирована по Международному стандарту ISO 9001;
- Лицензия ФСБ на осуществление работ с использованием сведений, составляющих государственную тайну;
- Поставка специализированных компонентов (Xilinx, Altera, Analog Devices, Intersil, Interpoint, Microsemi, Aeroflex, Peregrine, Syfer, Eurofarad, Texas Instrument, Miteq, Cobham, E2V, MA-COM, Hittite, Mini-Circuits, General Dynamics и др.);

Помимо этого, одним из направлений компании «ЭлектроПласт» является направление «Источники питания». Мы предлагаем Вам помощь Конструкторского отдела:

- Подбор оптимального решения, техническое обоснование при выборе компонента;
- Подбор аналогов;
- Консультации по применению компонента;
- Поставка образцов и прототипов;
- Техническая поддержка проекта;
- Защита от снятия компонента с производства.



#### Как с нами связаться

**Телефон:** 8 (812) 309 58 32 (многоканальный)

**Факс:** 8 (812) 320-02-42

**Электронная почта:** [org@eplast1.ru](mailto:org@eplast1.ru)

**Адрес:** 198099, г. Санкт-Петербург, ул. Калинина, дом 2, корпус 4, литера А.