

## Features

- Serial Peripheral Interface (SPI) Compatible
- Supports SPI Modes 0 (0,0) and 3 (1,1)
  - Data Sheet Describes Mode 0 Operation
- Low-voltage and Standard-voltage Operation
  - $V_{CC} = 1.8V$  to 5.5V
- 20MHz Clock Rate (5V)
- 64-byte Page Mode and Byte Write Operation
- Block Write Protection
  - Protect 1/4, 1/2, or Entire Array
- Write Protect ( $\overline{WP}$ ) Pin and Write Disable Instructions for Both Hardware and Software Data Protection
- Self-timed Write Cycle (5ms max)
- High Reliability
  - Endurance: 1,000,000 Write Cycles
  - Data Retention: 100 Years
- Green (Pb/Halogen-free/RoHS Compliant) Packaging Options
- Die Sales: Wafer Form, Waffle Pack, and Bumped Wafers

## Description

The Atmel® AT25128B/256B provides 131,072/262,144 bits of Serial Electrically Erasable Programmable Read-Only Memory (EEPROM) organized as 16,384/32,768 words of 8 bits each. The device is optimized for use in many industrial and commercial applications where low-power and low-voltage operation are essential. The AT25128B/256B is available in space saving JEDEC SOIC, TSSOP, UDFN, and VFBGA packages.

The AT25128B/256B is enabled through the Chip Select pin ( $\overline{CS}$ ) and accessed via a 3-Wire interface consisting of Serial Data Input (SI), Serial Data Output (SO), and Serial Clock (SCK). All programming cycles are completely self-timed, and no separate erase cycle is required before write.

Block Write protection is enabled by programming the status register with one of four blocks of Write Protection. Separate Program Enable and Program Disable instructions are provided for additional data protection. Hardware Data Protection is provided via the  $\overline{WP}$  pin to protect against inadvertent write attempts. The  $\overline{HOLD}$  pin may be used to suspend any serial communication without resetting the serial sequence.

# 1. Pin Configurations

**Table 1-1. Pin Configurations**

Pin Name	Function
$\overline{\text{CS}}$	Chip Select
GND	Ground
$\overline{\text{HOLD}}$	Suspends Serial Input
SCK	Serial Data Clock
SI	Serial Data Input
SO	Serial Data Output
$V_{\text{CC}}$	Power Supply
$\overline{\text{WP}}$	Write Protect

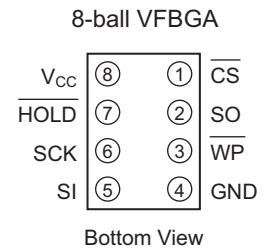
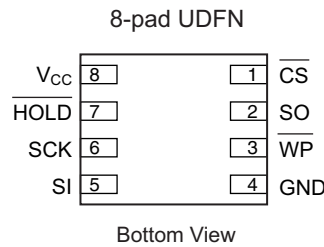
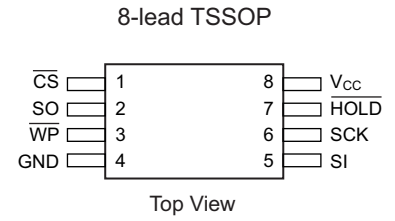
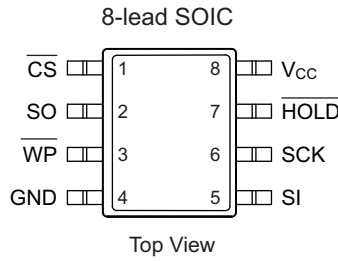

Note: Drawings are not to scale.

# 2. Absolute Maximum Ratings\*

Operating Temperature . . . . . -55°C to +125°C  
 Storage Temperature . . . . . -65°C to +150°C  
 Voltage on any pin  
 with respect to ground . . . . . -1.0V to +7.0V  
 Maximum Operating Voltage . . . . . 6.25V  
 DC Output Current . . . . . 5.0mA

\*Notice: Stresses beyond those listed under “Absolute Maximum Ratings” may cause permanent damage to the device. This is a stress rating only and functional operation of the device at these or any other conditions beyond those indicated in the operational sections of this specification is not implied. Exposure to absolute maximum rating conditions for extended periods may affect device reliability.

### 3. Block Diagram

Figure 3-1. Block Diagram

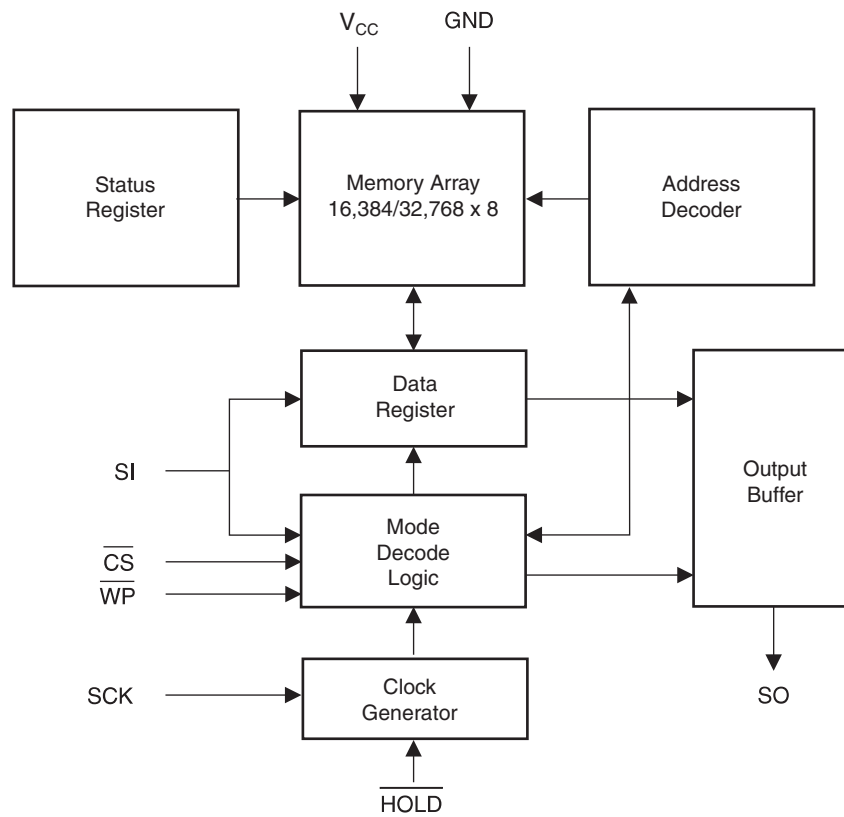

## 4. Electrical Characteristics

### 4.1 Pin Capacitance<sup>(1)</sup>

**Table 4-1. Pin Capacitance**

Applicable over recommended operating range from  $T_A = 25^\circ\text{C}$ ,  $f = 1\text{MHz}$ ,  $V_{CC} = +5\text{V}$  (unless otherwise noted).

Symbol	Test Conditions	Max	Units	Conditions
$C_{OUT}$	Output Capacitance (SO)	8	pF	$V_{OUT} = 0\text{V}$
$C_{IN}$	Input Capacitance ( $\overline{CS}$ , SCK, SI, $\overline{WP}$ , HOLD)	6	pF	$V_{IN} = 0\text{V}$

Note: 1. This parameter is characterized and is not 100% tested.

### 4.2 DC Characteristics

**Table 4-2. DC Characteristics**

Applicable over recommended operating range from:  $T_{AI} = -40^\circ\text{C}$  to  $+85^\circ\text{C}$ ,  $V_{CC} = +1.8\text{V}$  to  $+5.5\text{V}$ , (unless otherwise noted).

Symbol	Parameter	Test Condition	Min	Typ	Max	Units
$V_{CC1}$	Supply Voltage		1.8		5.5	V
$V_{CC2}$	Supply Voltage		2.5		5.5	V
$V_{CC3}$	Supply Voltage		4.5		5.5	V
$I_{CC1}$	Supply Current	$V_{CC} = 5\text{V}$ at 20MHz SO = Open, Read		9	10	mA
$I_{CC2}$	Supply Current	$V_{CC} = 5\text{V}$ at 10MHz SO = Open, Read, Write		5	7	mA
$I_{CC3}$	Supply Current	$V_{CC} = 5\text{V}$ at 1MHz SO = Open, Read, Write		2.2	3.5	mA
$I_{SB1}$	Standby Current	$V_{CC} = 1.8\text{V}$ , $\overline{CS} = V_{CC}$		0.2	3	$\mu\text{A}$
$I_{SB2}$	Standby Current	$V_{CC} = 2.5\text{V}$ , $\overline{CS} = V_{CC}$		0.5	3	$\mu\text{A}$
$I_{SB3}$	Standby Current	$V_{CC} = 5.0\text{V}$ , $\overline{CS} = V_{CC}$		2	5	$\mu\text{A}$
$I_{IL}$	Input Leakage	$V_{IN} = 0\text{V}$ to $V_{CC}$	-3		3	$\mu\text{A}$
$I_{OL}$	Output Leakage	$V_{IN} = 0\text{V}$ to $V_{CC}$ $T_{AC} = 0^\circ\text{C}$ to $70^\circ\text{C}$	-3		3	$\mu\text{A}$
$V_{IL}^{(1)}$	Input Low-voltage		-1		$V_{CC} \times 0.3$	V
$V_{IH}^{(1)}$	Input High-voltage		$V_{CC} \times 0.7$		$V_{CC} + 0.5$	V
$V_{OL1}$	Output Low-voltage	$3.6\text{V} \leq V_{CC} \leq 5.5\text{V}$		$I_{OL} = 3.00\text{mA}$	0.4	V
$V_{OH1}$	Output High-voltage	$3.6\text{V} \leq V_{CC} \leq 5.5\text{V}$		$I_{OH} = -1.60\text{mA}$	$V_{CC} - 0.8$	V
$V_{OL2}$	Output Low-voltage	$1.8\text{V} \leq V_{CC} \leq 3.6\text{V}$		$I_{OL} = 0.15\text{mA}$	0.2	V
$V_{OH2}$	Output High-voltage	$1.8\text{V} \leq V_{CC} \leq 3.6\text{V}$		$I_{OH} = -100\mu\text{A}$	$V_{CC} - 0.2$	V

Note: 1.  $V_{IL}$  min and  $V_{IH}$  max are reference only and are not tested.

## 4.3 AC Characteristics

**Table 4-3. AC Characteristics**

Applicable over recommended operating range from  $T_{AI} = -40$  to  $+85^{\circ}\text{C}$ ,  $V_{CC} = \text{As Specified}$ ,  $CL = 1$  TTL Gate and  $30\text{pF}$  (unless otherwise noted).

Symbol	Parameter	Voltage	Min	Max	Units
$f_{SCK}$	SCK Clock Frequency	4.5 – 5.5	0	20	MHz
		2.5 – 5.5	0	10	
		1.8 – 5.5	0	5	
$t_{RI}$	Input Rise Time	4.5 – 5.5		2	$\mu\text{s}$
		2.5 – 5.5		2	
		1.8 – 5.5		2	
$t_{FI}$	Input Fall Time	4.5 – 5.5		2	$\mu\text{s}$
		2.5 – 5.5		2	
		1.8 – 5.5		2	
$t_{WH}$	SCK High Time	4.5 – 5.5	20		ns
		2.5 – 5.5	40		
		1.8 – 5.5	80		
$t_{WL}$	SCK Low Time	4.5 – 5.5	20		ns
		2.5 – 5.5	40		
		1.8 – 5.5	80		
$t_{CS}$	$\overline{CS}$ High Time	4.5 – 5.5	100		ns
		2.5 – 5.5	100		
		1.8 – 5.5	200		
$t_{CSS}$	$\overline{CS}$ Setup Time	4.5 – 5.5	100		ns
		2.5 – 5.5	100		
		1.8 – 5.5	200		
$t_{CSH}$	$\overline{CS}$ Hold Time	4.5 – 5.5	100		ns
		2.5 – 5.5	100		
		1.8 – 5.5	200		
$t_{SU}$	Data In Setup Time	4.5 – 5.5	5		ns
		2.5 – 5.5	10		
		1.8 – 5.5	20		
$t_H$	Data In Hold Time	4.5 – 5.5	5		ns
		2.5 – 5.5	10		
		1.8 – 5.5	20		
$t_{HD}$	$\overline{\text{Hold}}$ Setup Time	4.5 – 5.5	5		ns
		2.5 – 5.5	10		
		1.8 – 5.5	20		
$t_{CD}$	$\overline{\text{Hold}}$ Hold Time	4.5 – 5.5	5		ns
		2.5 – 5.5	10		
		1.8 – 5.5	20		
$t_V$	Output Valid	4.5 – 5.5	0	20	ns
		2.5 – 5.5	0	40	
		1.8 – 5.5	0	80	
$t_{HO}$	Output Hold Time	4.5 – 5.5	0		ns
		2.5 – 5.5	0		
		1.8 – 5.5	0		

**Table 4-3. AC Characteristics (Continued)**

Applicable over recommended operating range from  $T_{AI} = -40$  to  $+85^{\circ}\text{C}$ ,  $V_{CC} = \text{As Specified}$ ,  $CL = 1$  TTL Gate and  $30\text{pF}$  (unless otherwise noted).

Symbol	Parameter	Voltage	Min	Max	Units
$t_{LZ}$	$\overline{\text{Hold}}$ to Output Low Z	4.5 – 5.5	0	25	ns
		2.5 – 5.5	0	50	
		1.8 – 5.5	0	100	
$t_{HZ}$	$\overline{\text{Hold}}$ to Output High Z	4.5 – 5.5		25	ns
		2.5 – 5.5		50	
		1.8 – 5.5		100	
$t_{DIS}$	Output Disable Time	4.5 – 5.5		25	ns
		2.5 – 5.5		50	
		1.8 – 5.5		100	
$t_{WC}$	Write Cycle Time	4.5 – 5.5		5	ms
		2.5 – 5.5		5	
		1.8 – 5.5		5	
Endurance <sup>(1)</sup>	3.3V, $25^{\circ}\text{C}$ , Page Mode		1,000,000		Write Cycles

Note: 1. This parameter is characterized and is not 100% tested.

## 5. Serial Interface Description

**Master:** The device that generates the serial clock.

**Slave:** Because the Serial Clock pin (SCK) is always an input, the AT25128B/256B always operates as a slave.

**Transmitter/Receiver:** The AT25128B/256B has separate pins designated for data transmission (SO) and reception (SI).

**MSB:** The Most Significant Bit (MSB) is the first bit transmitted and received.

**Serial Opcode:** After the device is selected with  $\overline{\text{CS}}$  going low, the first byte will be received. This byte contains the opcode which defines the operations to be performed.

**Invalid Opcode:** If an invalid opcode is received, no data will be shifted into the AT25128B/256B, and the serial output pin (SO) will remain in a high-impedance state until the falling edge of  $\overline{\text{CS}}$  is detected again. This will reinitialize the serial communication.

**Chip Select:** The AT25128B/256B is selected when the  $\overline{\text{CS}}$  pin is low. When the device is not selected, data will not be accepted via the SI pin, and the SO pin will remain in a high-impedance state.

**Hold:** The  $\overline{\text{HOLD}}$  pin is used in conjunction with the  $\overline{\text{CS}}$  pin to select the AT25128B/256B. When the device is selected and a serial sequence is underway,  $\overline{\text{HOLD}}$  can be used to pause the serial communication with the master device without resetting the serial sequence. To pause, the  $\overline{\text{HOLD}}$  pin must be brought low while the SCK pin is low. To resume serial communication, the  $\overline{\text{HOLD}}$  pin is brought high while the SCK pin is low (SCK may still toggle during  $\overline{\text{HOLD}}$ ). Inputs to the SI pin will be ignored while the SO pin is in the high-impedance state.

**Write Protect:** The Write Protect pin ( $\overline{\text{WP}}$ ) will allow normal read/write operations when held high. When the  $\overline{\text{WP}}$  pin is brought low and WPEN bit is one, all write operations to the status register are inhibited.  $\overline{\text{WP}}$  going low while  $\overline{\text{CS}}$  is still low will interrupt a write to the status register. If the internal write cycle has already been initiated,  $\overline{\text{WP}}$  going low will have no effect on any write operation to the status register. The  $\overline{\text{WP}}$  pin function is blocked when the WPEN bit in the status register is zero. This will allow the user to install the AT25128B/256B in a system with the  $\overline{\text{WP}}$  pin tied to ground and still be able to write to the status register. All  $\overline{\text{WP}}$  pin functions are enabled when the WPEN bit is set to one.

Figure 5-1. SPI Serial Interface

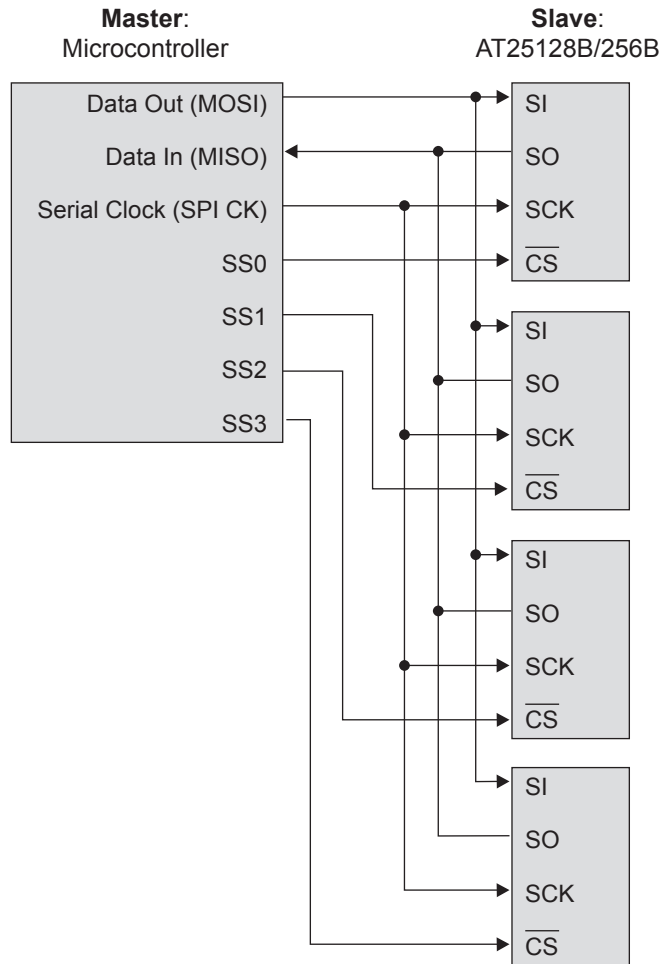

## 6. Functional Description

The AT25128B/256B is designed to interface directly with the synchronous Serial Peripheral Interface (SPI) of the 6800 series of microcontrollers.

The AT25128B/256B utilizes an 8-bit instruction register. The list of instructions and their operation codes are contained in [Figure 6-1](#). All instructions, addresses, and data are transferred with the MSB first and start with a high-to-low  $\overline{CS}$  transition.

**Table 6-1. Instruction Set for the AT25010B/020B/040B**

Instruction Name	Instruction Format	Operation
WREN	0000 X110	Set Write Enable Latch
WRDI	0000 X100	Reset Write Enable Latch
RDSR	0000 X101	Read Status Register
WRSR	0000 X001	Write Status Register
READ	0000 X011	Read Data from Memory Array
WRITE	0000 X010	Write Data to Memory Array

**Write Enable (WREN):** The device will power-up in the Write Disable state when  $V_{CC}$  is applied. All programming instructions must therefore be preceded by a Write Enable instruction. The  $\overline{WP}$  pin must be held high during a WREN instruction.

**Write Disable (WRDI):** To protect the device against inadvertent writes, the Write Disable instruction disables all programming modes. The WRDI instruction is independent of the status of the  $\overline{WP}$  pin.

**Read Status Register (RDSR):** The Read Status Register instruction provides access to the status register. The Read/Busy and Write Enable status of the device can be determined by the RDSR instruction. Similarly, the Block Write Protection bits indicate the extent of protection employed. These bits are set by using the WRSR instruction.

**Table 6-2. Status Register Format**

Bit 7	Bit 6	Bit 5	Bit 4	Bit 3	Bit 2	Bit 1	Bit 0
WPEN	X	X	X	BP1	BP0	WEN	$\overline{RDY}$

**Table 6-3. Read Status Register Bit Definition**

Bit	Definition
Bit 0 ( $\overline{RDY}$ )	Bit 0 = 0 ( $\overline{RDY}$ ) indicates the device is ready. Bit 0 = 1 indicates the write cycle is in progress.
Bit 1 (WEN)	Bit 1 = 0 indicates the device <i>is not</i> write enabled. Bit 1 = 1 indicates the device is write enabled.
Bit 2 (BP0)	See <a href="#">Table 6-4</a> .
Bit 3 (BP1)	See <a href="#">Table 6-4</a> .
Bits 4 to 6 are zeros when the device is not in an internal write cycle.	
Bit 7 (WPEN)	See <a href="#">Table 6-5</a> .
Bits 0 to 7 are ones during an internal write cycle.	



**Write Status Register (WRSR):** The WRSR instruction allows the user to select one of four levels of protection. The AT25128B/256B is divided into four array segments. None, one-quarter ( $\frac{1}{4}$ ), one-half ( $\frac{1}{2}$ ), or all of the memory segments can be protected. Any of the data within any selected segment will therefore be read-only. The block write protection levels and corresponding status register control bits are shown in [Table 6-4](#).

Bits BP1, BP0, and WPEN are nonvolatile cells that have the same properties and functions as the regular memory cells (e.g., WREN,  $t_{WC}$ , RDSR).

**Table 6-4. Block Write Protect Bits**

Level	Status Register Bits		Array Addresses Protected	
	BP1	BP0	AT25128B	AT25256B
0	0	0	None	None
1 ( $\frac{1}{4}$ )	0	1	3000 – 3FFF	6000 – 7FFF
2 ( $\frac{1}{2}$ )	1	0	2000 – 3FFF	4000 – 7FFF
3 (All)	1	1	0000 – 3FFF	0000 – 7FFF

The WRSR instruction also allows the user to enable or disable the write protect ( $\overline{WP}$ ) pin through the use of the Write Protect Enable (WPEN) bit. Hardware write protection is enabled when the  $\overline{WP}$  pin is low and the WPEN bit is one. The hardware write protection is disabled when either the  $\overline{WP}$  pin is high or the WPEN bit is zero. When the device is hardware write protected, writes to the Status Register including the Block Protect bits, the WPEN bit, and the block protected sections in the memory array are disabled. Writes are only allowed to sections of the memory which are not block-protected.

Note: When the WPEN bit is hardware write protected, it cannot be changed back to zero as long as the  $\overline{WP}$  pin is held low.

**Table 6-5. WPEN Operation**

WPEN	$\overline{WP}$	WEN	Protected Blocks	Unprotected Blocks	Status Register
0	X	0	Protected	Protected	Protected
0	X	1	Protected	Writable	Writable
1	Low	0	Protected	Protected	Protected
1	Low	1	Protected	Writable	Protected
X	High	0	Protected	Protected	Protected
X	High	1	Protected	Writable	Writable

**Read Sequence (READ):** Reading the AT25128B/256B via the SO pin requires the following sequence. After the  $\overline{CS}$  line is pulled low to select a device, the Read opcode is transmitted via the SI line followed by the byte address to be read ([Table 6-6](#)). Upon completion, any data on the SI line will be ignored. The data (D7 – D0) at the specified address is then shifted out onto the SO line. If only one byte is to be read, the  $\overline{CS}$  line should be driven high after the data comes out. The Read Sequence can be continued since the byte address is automatically incremented and data will continue to be shifted out. When the highest address is reached, the address counter will roll-over to the lowest address allowing the entire memory to be read in one continuous read cycle.

**Write Sequence (WRITE):** In order to program the AT25128B/256B, the Write Protect pin ( $\overline{WP}$ ) must be held high and two separate instructions must be executed. First, the device *must be write enabled* via the WREN instruction. Then a Write (WRITE) instruction may be executed. Also, the address of the memory location(s) to be programmed must be outside the protected address field location selected by the Block Write Protection level. During an internal write cycle, all commands will be ignored except the RDSR instruction.

A Write instruction requires the following sequence. After the  $\overline{CS}$  line is pulled low to select the device, the Write opcode is transmitted via the SI line followed by the byte address and the data (D7 – D0) to be programmed (see Table 6-6 for the address key). Programming will start after the  $\overline{CS}$  pin is brought high. The low-to-high transition of the  $\overline{CS}$  pin must occur during the SCK low time immediately after clocking in the D0 (LSB) data bit.

The Ready/Busy status of the device can be determined by initiating a Read Status Register (RDSR) instruction. If Bit 0 is one, the write cycle is still in progress. If Bit 0 is zero, the write cycle has ended. Only the RDSR instruction is enabled during the write programming cycle.

The AT25128B/256B is capable of an 64-byte Page Write operation. After each byte of data is received, the six low-order address bits are internally incremented by one; the high-order bits of the address will remain constant. If more than 64 bytes of data are transmitted, the address counter will roll-over, and the previously written data will be overwritten. The AT25128B/256B is automatically returned to the Write Disable state at the completion of a write cycle.

Note: If the  $\overline{WP}$  pin is brought low or if the device is not Write Enabled (WREN), the device will ignore the Write instruction and will return to the standby state, when  $\overline{CS}$  is brought high. A new CS falling edge is required to reinitiate the serial communication.

**Table 6-6. Address Key**

Address	AT25128B	AT25256B
$A_N$	$A_{13} - A_0$	$A_{14} - A_0$
Don't Care Bits	$A_{15} - A_{14}$	$A_{15}$

## 7. Timing Diagrams — SPI Mode 0 (0,0)

Figure 7-1. Synchronous Data Timing (for Mode 0)

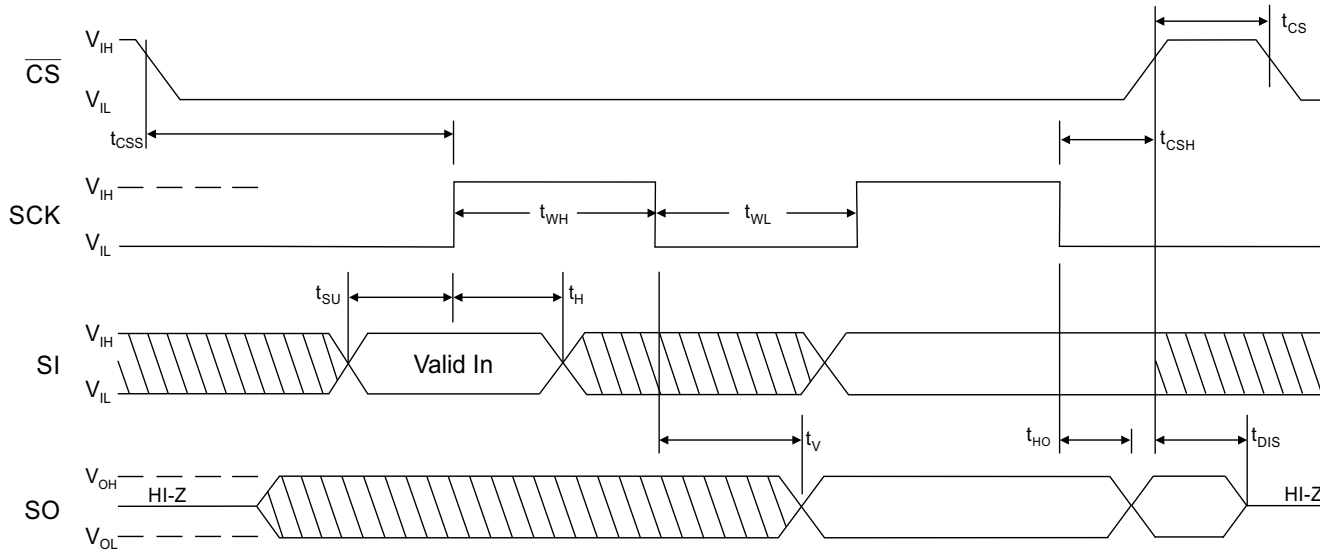

Figure 7-2. WREN Timing

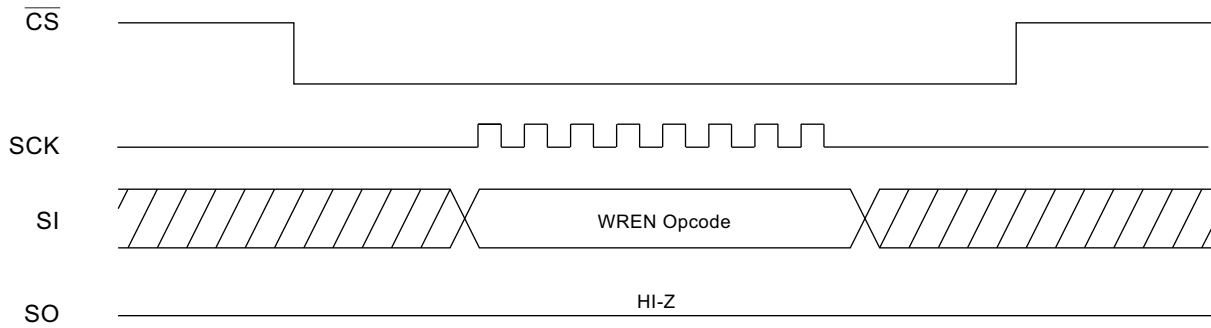
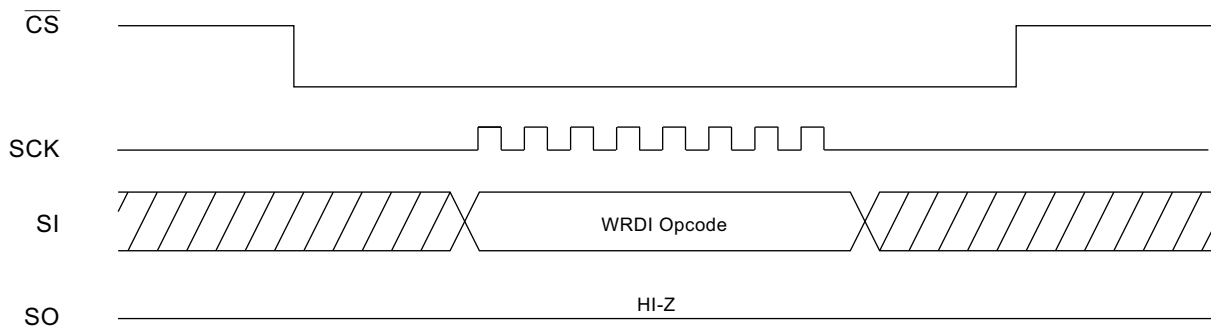

Figure 7-3. WRDI Timing



**Figure 7-4. RDSR Timing**



**Figure 7-5. WRSR Timing**

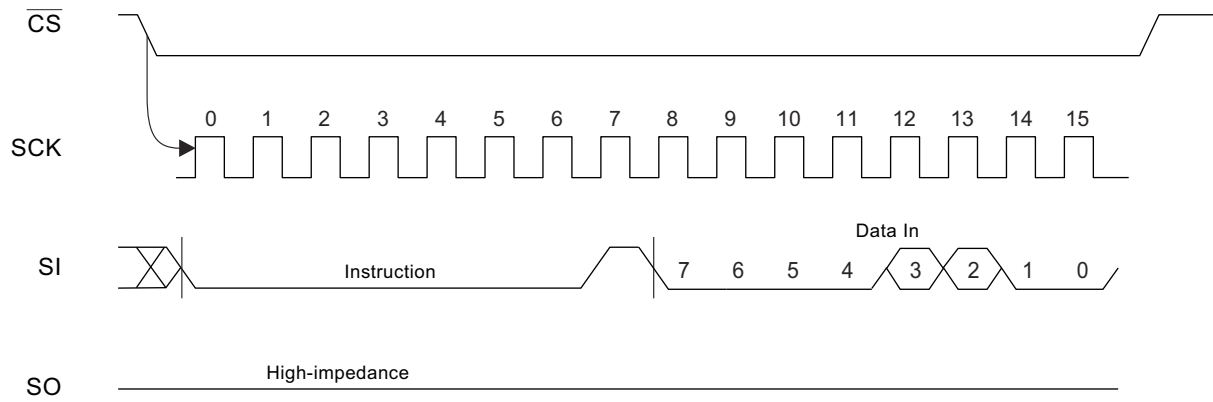

**Figure 7-6. READ Timing**



**Figure 7-7. WRITE Timing**

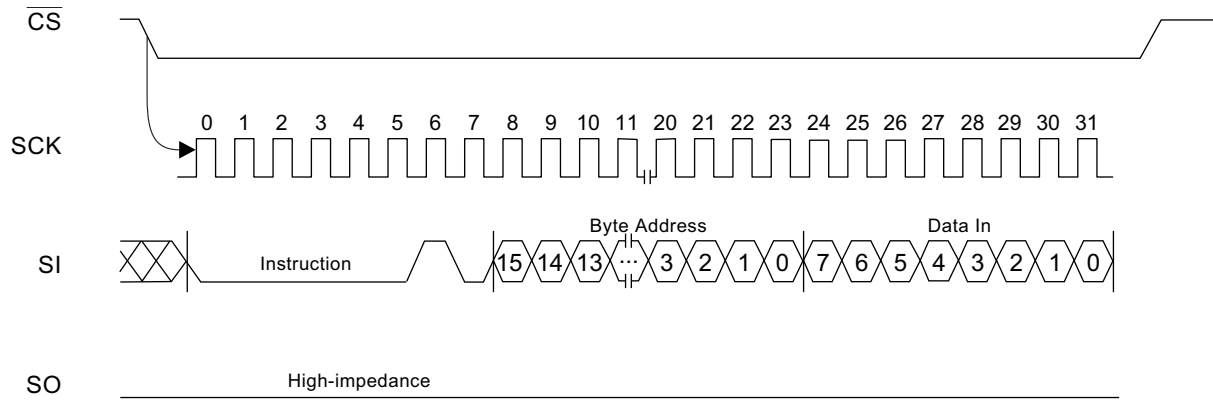

**Figure 7-8. HOLD Timing**

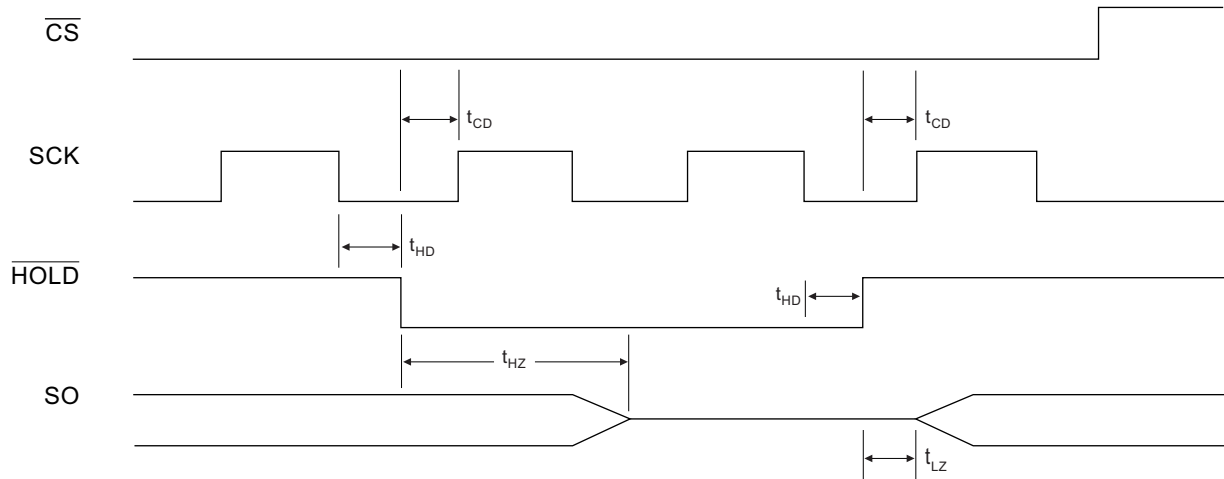

## 8. Ordering Code Detail

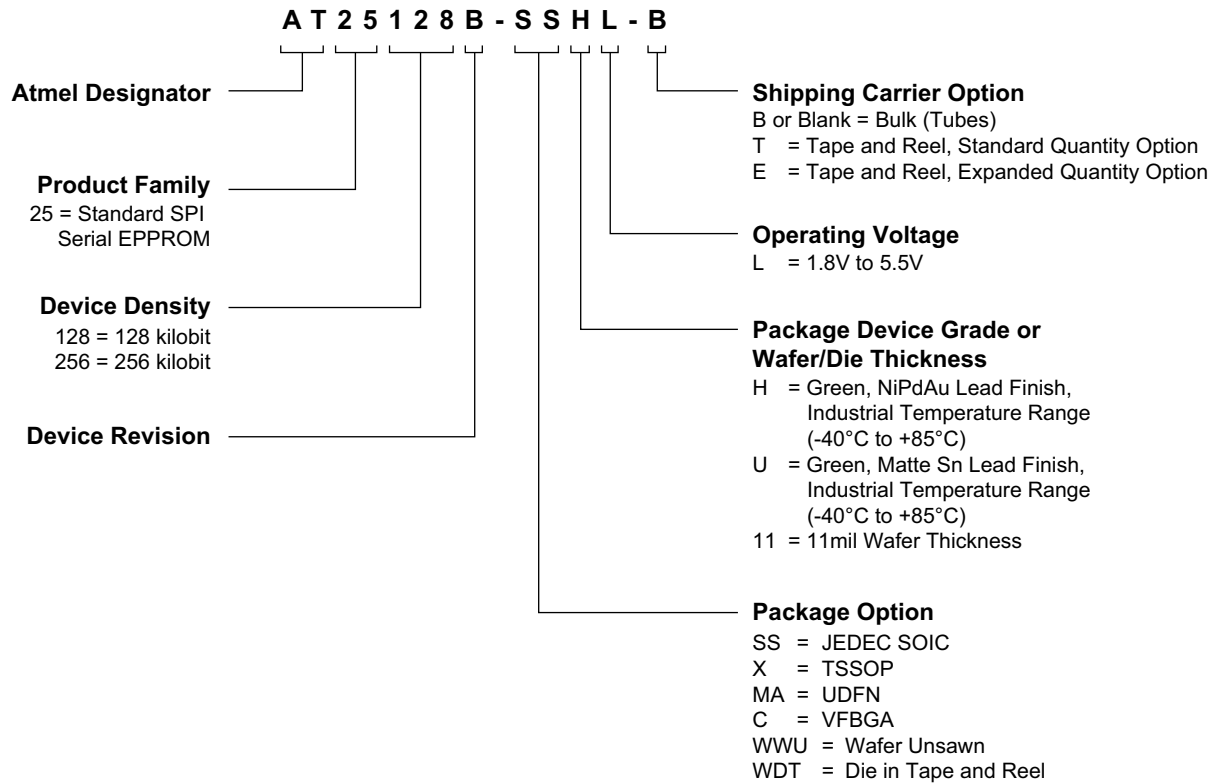

## 9. Part Markings

### AT25128B and AT25256B: Package Marking Information

<p>8-lead SOIC</p>	<p>8-lead TSSOP</p>
<p>8-pad UDFN</p> <p>2.0 x 3.0 mm Body</p>	<p>8-ball VFBGA</p> <p>2.35 x 3.73 mm Body</p>

Note 1: ● designates pin 1

Note 2: Package drawings are not to scale

Catalog Number Truncation			
AT25128B		Truncation Code ###: 5DB	
AT25256B		Truncation Code ###: 5EB	
Date Codes			Voltages
Y = Year	M = Month	WW = Work Week of Assembly	% = Minimum Voltage
4: 2014      8: 2018	A: January	02: Week 2	L: 1.8V min
5: 2015      9: 2019	B: February	04: Week 4	
6: 2016      0: 2020	...	...	
7: 2017      1: 2021	L: December	52: Week 52	
Country of Assembly		Lot Number	Grade/Lead Finish Material
@ = Country of Assembly		AAA...A = Atmel Wafer Lot Number	U: Industrial/Matte Tin/SnAgCu H: Industrial/NiPdAu
Trace Code			Atmel Truncation
XX = Trace Code (Atmel Lot Numbers Correspond to Code) Example: AA, AB.... YZ, ZZ			AT: Atmel ATM: Atmel ATML: Atmel

3/11/14

<p>Package Mark Contact: DL-CSO-Assy_eng@atmel.com</p>	<p><b>TITLE</b></p> <p><b>25128-256BSM</b>, AT25128B and AT25256B Package Marking Information</p>	<p><b>DRAWING NO.</b></p> <p>25128-256BSM</p>	<p><b>REV.</b></p> <p>A</p>
--	---	---	-----------------------------

## 10. Ordering Information

Atmel Ordering Code	Lead Finish	Package	Delivery Information		Operation Range
			Form	Quantity	
AT25128B-SSHL-B	NiPdAu (Lead-free/Halogen-free)	8S1	Bulk (Tubes)	100 per Tube	Industrial Temperature (-40 to +85°C)
AT25128B-SSHL-T			Tape and Reel	4,000 per Reel	
AT25128B-XHL-B		8X	Bulk (Tubes)	100 per Tube	
AT25128B-XHL-T			Tape and Reel	5,000 per Reel	
AT25128B-MAHL-T		8MA2	Tape and Reel	5,000 per Reel	
AT25128B-MAHL-E			Tape and Reel	15,000 per Reel	
AT25128B-CUL-T	SnAgCu (Lead-free/Halogen-free)	8U2-1	Tape and Reel	5,000 per Reel	
AT25128B-WWU11L <sup>(1)</sup>	N/A	Wafer	Note 1		
AT25256B-SSHL-B	NiPdAu (Lead-free/Halogen-free)	8S1	Bulk (Tubes)	100 per Tube	Industrial Temperature (-40 to +85°C)
AT25256B-SSHL-T			Tape and Reel	4,000 per Reel	
AT25256B-XHL-B		8X	Bulk (Tubes)	100 per Tube	
AT25256B-XHL-T			Tape and Reel	5,000 per Reel	
AT25256B-MAHL-T		8MA2	Tape and Reel	5,000 per Reel	
AT25256B-MAHL-E			Tape and Reel	15,000 per Reel	
AT25256B-CUL-T	SnAgCu (Lead-free/Halogen-free)	8U2-1	Tape and Reel	5,000 per Reel	
AT25256B-WWU11L <sup>(1)</sup>	N/A	Wafer	Note 1		

Note: 1. Contact Atmel Sales for Wafer sales.

Package Type	
<b>8S1</b>	8-lead, 0.15" wide, Plastic Gull Wing Small Outline (JEDEC SOIC)
<b>8X</b>	8-lead, 4.40mm body, Plastic Thin Shrink Small Outline Package (TSSOP)
<b>8MA2</b>	8-pad, 2.00mm x 3.00mm body, 0.50mm pitch, Plastic Ultra Thin Dual Flat No Lead (UDFN)
<b>8U2-1</b>	8-ball, 2.35mm x 3.73mm body, 0.75mm pitch, Very Thin, Fine-Pitch Ball Grid Array (VFBGA)



# 11. Packaging Information

## 11.1 8S1 — 8-lead JEDEC SOIC



## 11.2 8X — 8-lead TSSOP



### 11.3 8MA2 — 8-pad UDFN



11/26/14

**Atmel**

Package Drawing Contact:  
packagedrawings@atmel.com

**TITLE**

8MA2, 8-pad 2 x 3 x 0.6mm Body, Thermally Enhanced Plastic Ultra Thin Dual Flat No-Lead Package (UDFN)

**GPC**

YNZ

**DRAWING NO.**

8MA2

**REV.**

G

## 11.4 8U2-1 — 8-ball VFBGA

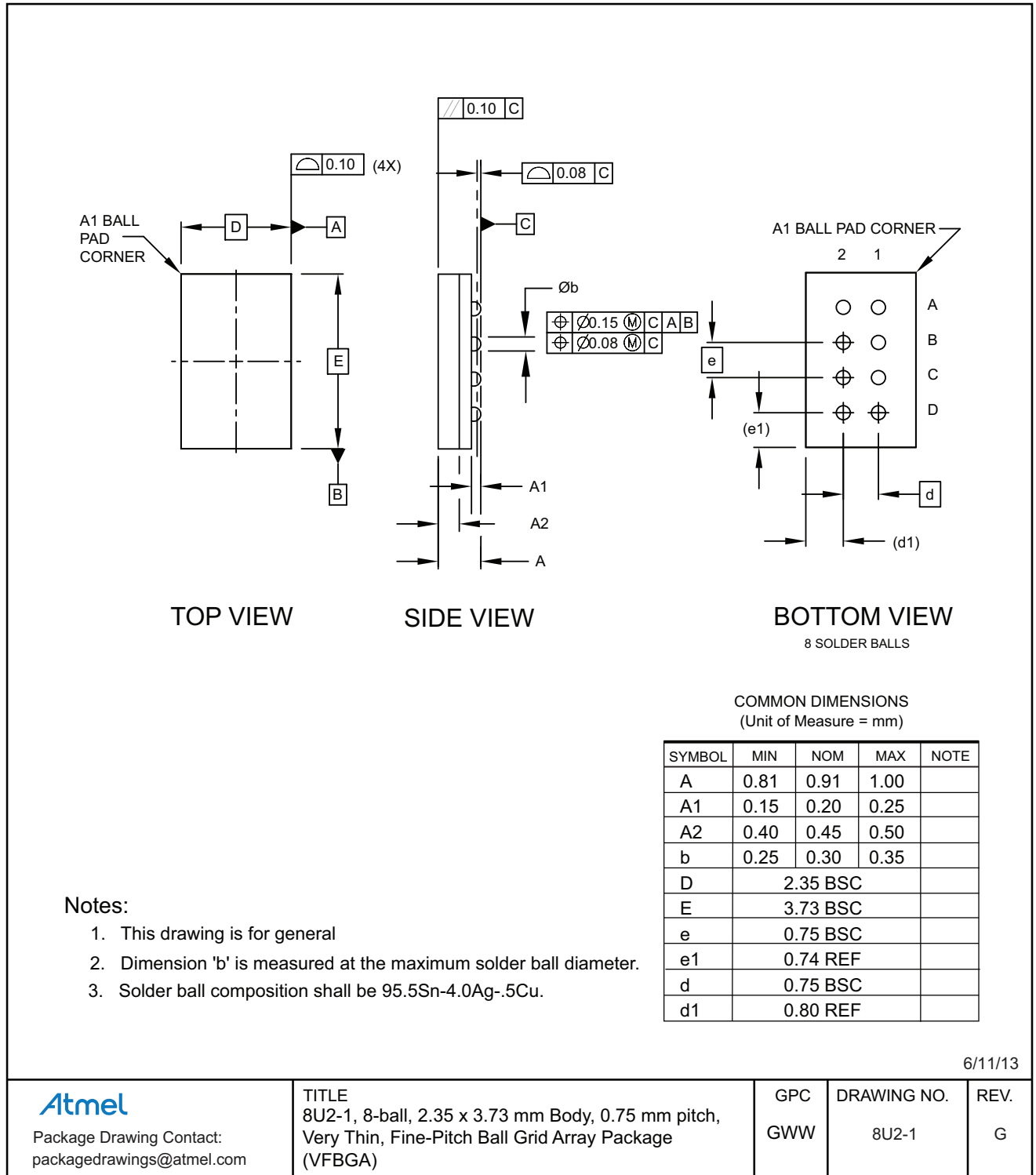

## 12. Revision History

Doc. Rev.	Date	Comments
8698E	01/2015	Add the UDFN Expanded Quantity Option and ordering information. Update the 8MA2 package outline drawing.
8698D	07/2014	Update part markings, 8MA2 and 8U2-1 package drawings, package 8A2 to 8X, template, logos, and disclaimer page. No change to functional specification.
8698C	08/2011	Update 8A2 and 8S1 package drawings. Correct page 13, Device Density from 156K to 256K. Correct page 9, table headings. Correct cross references on pages 7, 8, and 9.
8698B	03/2010	Update Catalog Numbering Scheme. Update Ordering Information and package types.
8698A	12/2009	Initial document release.



**Atmel Corporation** 1600 Technology Drive, San Jose, CA 95110 USA T: (+1)(408) 441.0311 F: (+1)(408) 436.4200 | [www.atmel.com](http://www.atmel.com)

© 2015 Atmel Corporation. / Rev.: Atmel-8698E-SEEPROM-AT25128B-256B-Datasheet\_012015.

Atmel®, Atmel logo and combinations thereof, Enabling Unlimited Possibilities®, and others are registered trademarks or trademarks of Atmel Corporation in U.S. and other countries. Other terms and product names may be trademarks of others.

DISCLAIMER: The information in this document is provided in connection with Atmel products. No license, express or implied, by estoppel or otherwise, to any intellectual property right is granted by this document or in connection with the sale of Atmel products. EXCEPT AS SET FORTH IN THE ATMEL TERMS AND CONDITIONS OF SALES LOCATED ON THE ATMEL WEBSITE, ATMEL ASSUMES NO LIABILITY WHATSOEVER AND DISCLAIMS ANY EXPRESS, IMPLIED OR STATUTORY WARRANTY RELATING TO ITS PRODUCTS INCLUDING, BUT NOT LIMITED TO, THE IMPLIED WARRANTY OF MERCHANTABILITY, FITNESS FOR A PARTICULAR PURPOSE, OR NON-INFRINGEMENT. IN NO EVENT SHALL ATMEL BE LIABLE FOR ANY DIRECT, INDIRECT, CONSEQUENTIAL, PUNITIVE, SPECIAL OR INCIDENTAL DAMAGES (INCLUDING, WITHOUT LIMITATION, DAMAGES FOR LOSS AND PROFITS, BUSINESS INTERRUPTION, OR LOSS OF INFORMATION) ARISING OUT OF THE USE OR INABILITY TO USE THIS DOCUMENT, EVEN IF ATMEL HAS BEEN ADVISED OF THE POSSIBILITY OF SUCH DAMAGES. Atmel makes no representations or warranties with respect to the accuracy or completeness of the contents of this document and reserves the right to make changes to specifications and products descriptions at any time without notice. Atmel does not make any commitment to update the information contained herein. Unless specifically provided otherwise, Atmel products are not suitable for, and shall not be used in, automotive applications. Atmel products are not intended, authorized, or warranted for use as components in applications intended to support or sustain life.

SAFETY-CRITICAL, MILITARY, AND AUTOMOTIVE APPLICATIONS DISCLAIMER: Atmel products are not designed for and will not be used in connection with any applications where the failure of such products would reasonably be expected to result in significant personal injury or death ("Safety-Critical Applications") without an Atmel officer's specific written consent. Safety-Critical Applications include, without limitation, life support devices and systems, equipment or systems for the operation of nuclear facilities and weapons systems. Atmel products are not designed nor intended for use in military or aerospace applications or environments unless specifically designated by Atmel as military-grade. Atmel products are not designed nor intended for use in automotive applications unless specifically designated by Atmel as automotive-grade.



Компания «ЭлектроПласт» предлагает заключение долгосрочных отношений при поставках импортных электронных компонентов на взаимовыгодных условиях!

Наши преимущества:

- Оперативные поставки широкого спектра электронных компонентов отечественного и импортного производства напрямую от производителей и с крупнейших мировых складов;
- Поставка более 17-ти миллионов наименований электронных компонентов;
- Поставка сложных, дефицитных, либо снятых с производства позиций;
- Оперативные сроки поставки под заказ (от 5 рабочих дней);
- Экспресс доставка в любую точку России;
- Техническая поддержка проекта, помощь в подборе аналогов, поставка прототипов;
- Система менеджмента качества сертифицирована по Международному стандарту ISO 9001;
- Лицензия ФСБ на осуществление работ с использованием сведений, составляющих государственную тайну;
- Поставка специализированных компонентов (Xilinx, Altera, Analog Devices, Intersil, Interpoint, Microsemi, Aeroflex, Peregrine, Syfer, Eurofarad, Texas Instrument, Miteq, Cobham, E2V, MA-COM, Hittite, Mini-Circuits, General Dynamics и др.);

Помимо этого, одним из направлений компании «ЭлектроПласт» является направление «Источники питания». Мы предлагаем Вам помощь Конструкторского отдела:

- Подбор оптимального решения, техническое обоснование при выборе компонента;
- Подбор аналогов;
- Консультации по применению компонента;
- Поставка образцов и прототипов;
- Техническая поддержка проекта;
- Защита от снятия компонента с производства.



#### Как с нами связаться

**Телефон:** 8 (812) 309 58 32 (многоканальный)

**Факс:** 8 (812) 320-02-42

**Электронная почта:** [org@eplast1.ru](mailto:org@eplast1.ru)

**Адрес:** 198099, г. Санкт-Петербург, ул. Калинина, дом 2, корпус 4, литера А.