

Helping Customers Innovate, Improve & Grow



Description

The VI CD-700 is a user-configurable crystal based PLL integrated circuit. It includes a digital phase detector, op-amp, VCXO and additional integrated functions for use in digital synchronization applications. Loop filter software is available as well SPICE models for circuit simulation.

Features

- 5 x 7.5 x 2 mm, smallest VCXO PLL available
- Output Frequencies to 77.76 MHz
- 5.0 or 3.3 Vdc operation
- Tri-State Output
- Holdover on Loss of Signal Alarm
- VCXO with CMOS outputs
- 0/70 or -40/85 °C temperature range
- Hermetically sealed ceramic SMD package
- Product is compliant to RoHS directive 

Applications

- Frequency Translation
- Clock Smoothing, Clock Switching
- NRZ Clock recovery
- DSLAM, ADM, ATM, Aggregation, Optical Switching/Routing,
- Base Station
- Synchronous Ethernet
- Low jitter PLL's

Block Diagram

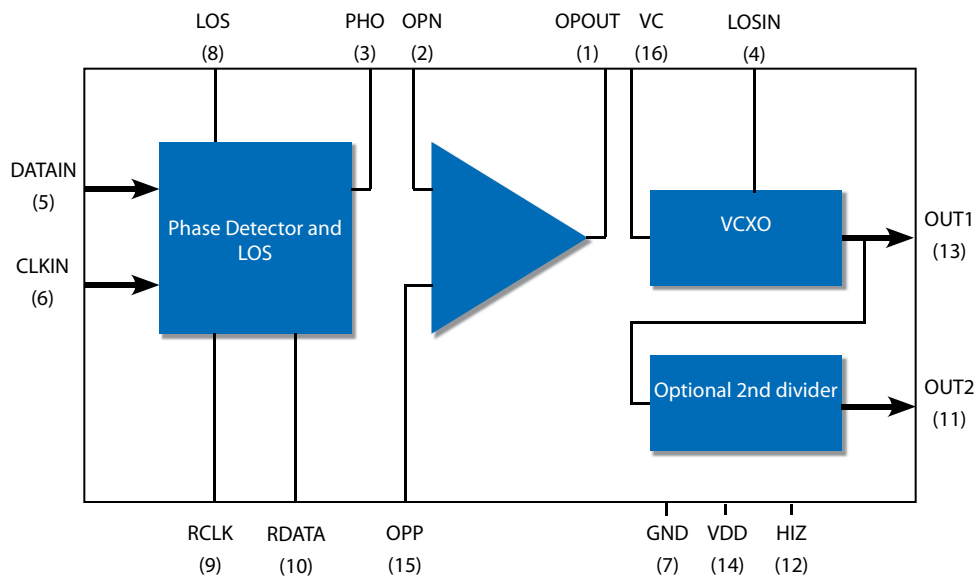

Performance Specifications

Table 1. Electrical Performance

Parameter	Symbol	Min	Typical	Maximum	Units
Output Frequency (<i>ordering option</i>) OUT 1, 5.0 V option OUT 1, 3.3 V option		1.000 1.000		77.760 77.760	MHz MHz
Supply Voltage ¹ +5.0 +3.3	V_{DD}	4.5 2.97	5.0 3.3	5.5 3.63	V V
Supply Current	I_{DD}			63	mA
Output Logic Levels Output Logic High ² Output Logic Low ²	V_{OH} V_{OL}	2.5		0.5	V V
Output Transition Times Rise Time ² Fall Time ²	t_R t_F			3.0 3.0	ns ns
Input Logic Levels Input Logic High ² Input Logic Low ²	V_{IH} V_{IL}	2.0		0.5	V V
Loss of Signal Indication Output Logic High ² Output Logic Low ²	V_{OH} V_{OL}	2.5		0.5	V V
Nominal Frequency on Loss of Signal Output 1 Output 2				± 75 ± 75	ppm ppm
Symmetry or Duty Cycle ³ Out 1 Out 2 RCLK	SYM1 SYM2 RCLK			40/60 45/55 40/60	% % %
Absolute Pull Range (<i>ordering option</i>) <i>over operating temperature, aging, and power supply variations</i>	APR	± 50 ± 80 ± 100			ppm
Test Conditions for APR (+5.0 V option)	V_C	0.5		4.5	V
Test Conditions for APR (+3.3 V option)	V_C	0.3		3.0	V
Gain Transfer	Kv	Positive			
Phase Detector Gain +5.0 V option +3.3 V option	Kv	0.53 0.35			rad/V rad/V
Operating temperature (<i>ordering option</i>)	T_{OP}	0/70 or -40/85			°C
Control Voltage Leakage Current	$I_{V_{CXO}}$			± 1.0	μA

1. A 0.01 μF and 0.1 μF parallel capacitor should be located as close to pin 14 as possible (and grounded).

2. Figure 2 defines these parameters. Figure 3 illustrates the equivalent five gate TTL load and operating conditions under which these parameters are tested and specified. Loads greater than 15 pF will adversely effect rise/fall time as well as symmetry.

3. Symmetry is defined as (ON TIME/PERIOD with $V_S=1.4$ V for both 5.0 V and 3.3 V operation).

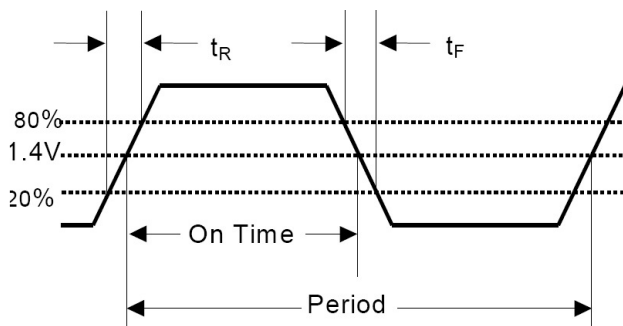

Figure 2. Output Waveform

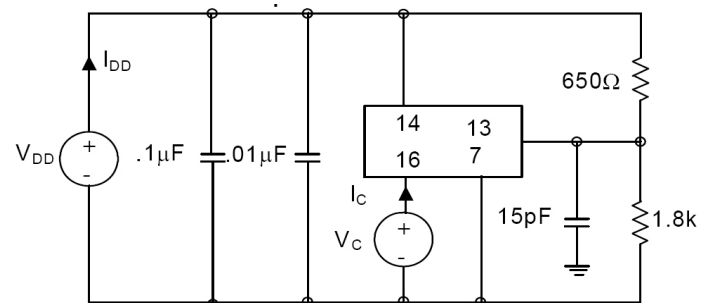

Figure 3. OUT1, OUT2, RCLK, RDATA Test Conditions (25 \pm 5°C)

Absolute Maximum Ratings

Stresses in excess of the absolute maximum ratings can permanently damage the device. Functional operation is not implied at these or any other conditions in excess of conditions represented in the operational sections of this data sheet. Exposure to absolute maximum ratings for extended periods may adversely affect device reliability.

Table 2. Absolute Maximum Ratings

Parameter	Symbol	Ratings	Unit
Power Supply	VDD	7	Vdc
Storage Temperature	Tstorage	-55/125	°C
Soldering Temperature/Duration	TPEAK / tP	260 / 40	°C/sec
Clock and Data Input Range	CLKIN, DATAIN	Gnd-0.5 to V _{DD} +0.5	V

Reliability

The CD-700 is capable of meeting the following qualification tests:

Table 3. Environmental Compliance

Parameter	Conditions
Mechanical Shock	MIL-STD-883, Method 2002
Mechanical Vibration	MIL-STD-883, Method 2007
Solderability	MIL-STD-883, Method 2003
Gross and Fine Leak	MIL-STD-883, Method 1014, 100% Tested
Resistance to Solvents	MIL-STD-883, Method 2016

Handling Precautions

Although ESD protection circuitry has been designed into the the CD-700, proper precautions should be taken when handling and mounting. VI employs a Human Body Model (HBM) and a Charged Device Model (CDM) for ESD susceptibility testing and design protection evaluation. ESD thresholds are dependent on the circuit parameters used to define the model.

Table 4. Predicted ESD R\$atings

Model	Minimum	Conditions
Human Body Model	1500 V	MIL-STD 883, Method 3015
Charged Device Model	1000 V	JESD 22-C101

Phase Detector

The phase detector has two buffered inputs (DATAIN and CLKIN) which are designed to switch at 1.4 volts. DATAIN is designed to accept an NRZ data stream but may also be used for clock signals which have a 50% duty cycle. CLKIN is connected to OUT1 or OUT2, or a divided version of one of these outputs. CLKIN and DATAIN are protected by ESD diodes and should not exceed the power supply voltage or ground by more than a few hundred millivolts.

The phase detector is basically a latched flip flop/exclusive-or gate/differential amplifier filter design to produce a DC signal proportional to the phase between the CLKIN and DATAIN signals (see Figure 4 for a block diagram and Figure 5 for an open loop transfer curve). This will simplify the PLL design as the designer does not have to filter narrow pulse signals to a DC level. Under locked conditions the rising edge of CLKIN will be centered in the middle of the DATAIN signal (see Figure 6).

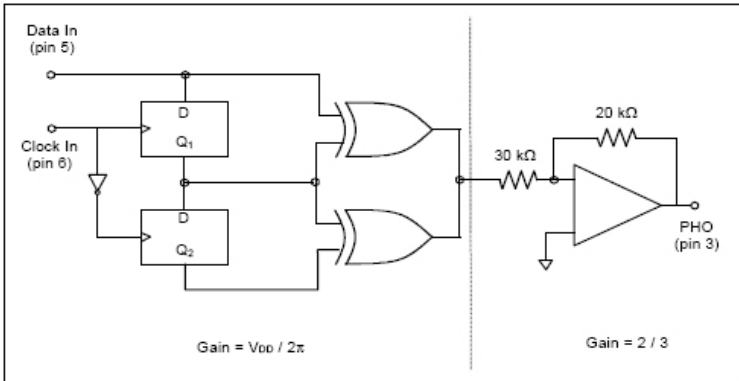

Figure 4. Simplified Phase Detector Block Diagram

The phase detector gain is 0.53V/rad x data density for 5volt operation and 0.35V/rad x data density for 3.3 volt operation. Data density is equal to 1.0 for clock signals and is system dependent on coding and design for NRZ signals, but 0.25 could be used as a starting point for data density.

The phase detector output is a DC signal for DATAIN frequencies greater than 1 MHz but produces significant ripple when inputs are less than 200 kHz. Additional filtering is required for lower input frequencies applications such as 8kHz (see Figures 8 and 9 as examples).

Under closed loop conditions the active filter has a blocking capacitor which provides a very high DC gain, so under

normal locked conditions and input frequencies >1 MHz, PHO will be about $V_{DD}/2$ and will not vary significantly with changes in input frequency (within lock range). The control voltage (pin 16) will vary according to the input frequency offset, but PHO will remain relatively constant.

Recovered Clock and Data Alignment Outputs

The CD-700 is designed to recover an embedded clock from an NRZ data signal and retime it with a data pattern. In this application, the VCXO frequency is exactly the same frequency as the NRZ data rate and the outputs are taken off Pin 9 (RCLK), and Pin 10 (RDATA). Under locked conditions, the falling edge of RCLK is centered in the RDATA pattern. Also, there is a 1.5 clock cycle delay between DATAIN and RDATA. Figure 6 shows the relationship between the DATAIN, CLKIN, RDATA and RCLK.

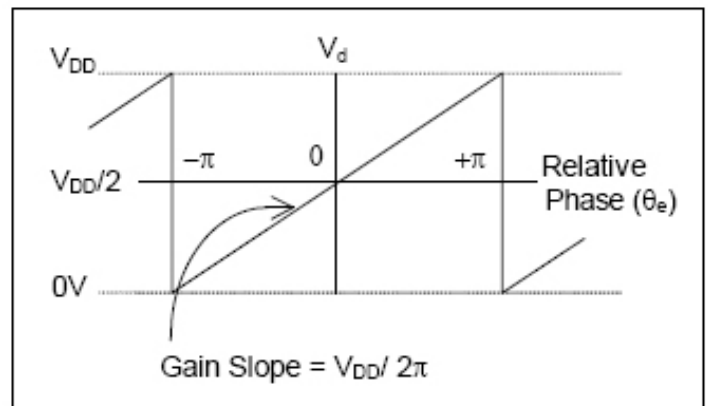

Figure 5. Open Loop Phase Detector Transfer Curve

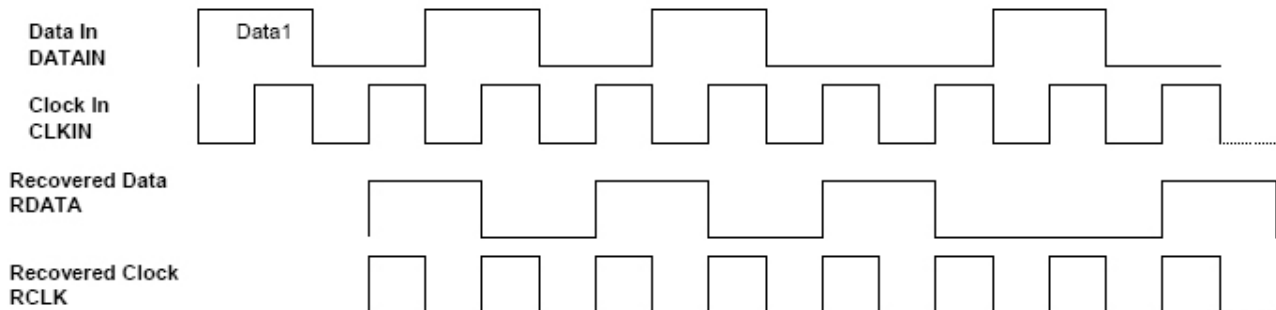

Figure 6. Clock and Data Timing Relationships for the NRZ data

Other RZ encoding schemes such as Manchester or AMI can be accommodated by using a CD-700 at twice the baud rate.

Loss of Signal, LOS and LOSIN

The LOS circuit provides an output alarm flag when the DATAIN input signal is lost. The LOS output is normally a logic low and is set to a logic high after 256 consecutive clock periods on CLKIN with no detected DATAIN transitions. This signal can be used to either flag external alarm circuits and/or drive the CD-700's LOSIN input. When LOSIN is set to a logic high, the VCXO control voltage (pin 16) is switched to an internal voltage which sets OUT1 and OUT2 to center frequency +/-75ppm. Also, LOS automatically closes the op amp feedback which means the op-amp is a unity gain buffer and will produce a DC voltage equal to the +op amp voltage (pin 15), usually VDD/2.

VCXO and Absolute Pull Range (APR) Specification

The CD-700's VCXO is a varactor tuned crystal oscillator, which produces an output frequency proportional to the control voltage (pin 16). The frequency deviation of the CD-700 VCXO is specified in terms of Absolute Pull Range (APR). APR provides the user with a guaranteed specification for minimum available frequency deviation over all operating conditions. Operating conditions include power supply variation, operating temperature range, and differences in output loading and changes due to aging.

A CD-700 VCXO with an APR of +/-50 ppm will track a +/-50 ppm reference source over all operating conditions. The fourth character of the product code in Table 7 specifies absolute Pull Range (APR). Please see Vectron's web site (www.vectron.com) for the APR Application Note. APR is tested at 0.5 and 4.5 volts for the 5.0 volt option and 0.3 and 3.0 volts for the 3.3 volt option.

VCXO Aging

Quartz oscillators typically exhibit a part per million shift in output frequency during aging. The major factors, which lead to this shift, are changes in the mechanical stress on the crystal and mass-loading on the crystal.

As the oscillator ages, relaxation of the crystal mounting stress or transfer of environmental stress through the package to the crystal mounting arrangement can lead to frequency variations. VI has minimized these two effects through the use of a miniature AT-cut strip resonator crystal which allows a superior mounting arrangement. This results in minimal relaxation and almost negligible environmental stress transfer.

VI has eliminated the impact of mass loading by ensuring hermetic integrity and minimizing out-gassing by limiting the number of internal components through the use of ASIC technology. Mass-loading on the crystal generally results in a frequency decrease and is typically due to out-gassing of material within a hermetic package or from contamination by external material in a non-hermetic package. Under normal operating conditions the CD-700 will typically exhibit 2 ppm aging in the first year of operation. The device will then typically exhibit 1 ppm aging the following year with a logarithmic decline each year thereafter.

Frequency Divider Feature

The lowest available VCXO OUT1 frequency is 1.000 MHz. To achieve lower frequencies, OUT1 is divided by a 2ⁿ counter (n = 1 to 8) and is the OUT2 frequency. The divider values (2, 4, 8, 16, 32, 64, 128 and 256) are set at the factory, so it is user selectable upon ordering only. In addition, a disabled OUT2 option is also available. To achieve 1.024 MHz, a CD-700 with OUT1 frequency equal to 16.384 MHz and a divider value equal to 16 would be used. Additional external divider circuits can be used to further lower or change the frequency.

Loop Filter

A PLL is a feedback system which forces the output frequency to lock in both phase and frequency to the input frequency. While there will be some phase error, theory states there is no frequency error. The loop filter design will dictate many key parameters such as jitter reduction, stability, lock range and acquisition time. Be advised that many textbook equations describing loop dynamics, such as capture range are based on ideal systems. Such equations may not be accurate for real systems due to nonlinearities, DC offsets, noise and do not take into account the limited VCXO bandwidth. This section deals with some real world design examples. Also, there is loop filter software on the Vectron web site, plus a full staff of experienced applications engineers who are eager to assist in this process. Common CD-700 PLL applications are shown in Figures 8, 9 (frequency translation), Figure 10 (clock recovery) and Figure 11 (clock smoothing).

Of primary concern to the designer is selecting a loop filter that insures lock-in, stability and provides adequate filtering of the input signal. For low input frequencies, a good starting point for the loop filter bandwidth is 10 Hz (typical). An example would be translating an 8 kHz signal to 44.736 MHz. Figures 8 and 9 show 8kHz to 44.736 MHz and 8kHz to 19.440 MHz frequency translation designs. For high input frequencies, a good starting point for the loop filter bandwidth is 100 ppm times the input frequency.

It's fairly easy to set a low loop bandwidth for large frequency translations such as 8kHz to 44.736MHz, but becomes more difficult for clock smoothing applications such as 19.440 MHz input and 19.440MHz output. In this example, $100\text{ppm} \times 19.440\text{MHz}$ is approximately 2kHz and this loop filter bandwidth may be too high to adequately reject jitter. A good way to resolve this is to lower the DATAIN frequency such as dividing the input frequency down. The loop filter bandwidth becomes lower since $100\text{ppm} \times \text{DATAIN}$ is lowered. Figure 11 shows an example for clock smoothing on a relatively high input frequency signal and maintaining a wide lock range.

There is no known accurate formula for calculating acquisition time and so the best way to provide realistic figures is to measure the lock time for a CD-700. By measuring the control voltage settling time, acquisition time was measured in the range of 3-5 seconds for applications such as 8kHz to 34.368 MHz frequency translation which is similar to the application in Figures 8 and 9, to sub 10 milliseconds for NRZ data patterns such as Figure 10. It may be tempting to reduce the damping factor to 0.7 or 1.0 in order to improve acquisition time; but, it degrades stability and will not significantly improve acquisition time. A damping factor of 4 is fairly conservative and allows for excellent stability.

Some general guidelines for selecting the loop filter elements include: Values should be less than 1Megohm and at least 10kohm between the PHO and OPN, the capacitor should be low leakage and a polarized capacitor is acceptable, the R/C's should be located physically close to the CD-700. The loop filter software available on the web site was written for 5 volt operation. A simple way to calculate values for 3.3 volt operation is to multiply the data density by 0.66 ($3.3\text{V} / 5\text{V}$).

SPICE models are another design aid. In most cases a new PLL CD-700 design is calculated by using the software and verified with SPICE models. The simple active SPICE model is shown in Figure 7.

Loop filter values can be modified to suit the system requirements and application. There are many excellent references on designing PLL's, such as "Phase-Locked Loops, Theory, Design and Applications", by Roland E Best (McGraw-Hill).

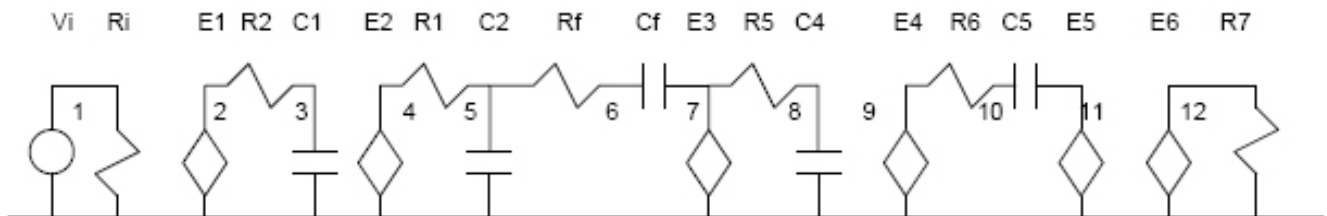

Figure 7. SPICE Model

*****CD-700 ac Loop model

vi 1 0 ac 1
ri 1 0 1k

*****Phase Detector

e1 2 0 1 0 1 (for closed loop response use: e1 2 0 1 12 1)
r2 2 3 30k
c1 3 0 60p

*****Phase Detector Gain= $0.53 \times \text{Data Density}$ (Data Density = 1 for clocks) for 5 volt operation and = $0.35 \times \text{Data Density}$ for 3.3 volt operation
e2 4 0 3 0 .35

*****Loop filter

r1 4 5 60k
c2 5 0 10p
rf 5 6 90k
cf 6 7 1.0u
e3 7 0 5 0 -10000

```

***** VCXO, Input Bandwidth=50kHz
r5 7 8 160k
c4 8 0 20p

```

```

*****VCXO Gain x 2Π (Example: 19.440 MHz x 100 ppm x 2 x Π)
e4 9 0 8 0 12214

```

```

*****1/S model
r6 9 10 1000
c5 10 11 0.001u
e5 11 0 10 0 -1e6

```

```

****Divide by n
e6 12 0 11 0 1
r7 12 0 1k

```

The bold numbers are user selectable R and C values that will vary depending on the application (see Figure 11).

Layout Considerations

To achieve stable, low noise performance good analog layout techniques should be incorporated and a partial list is shown below.

The CD-700 should be treated more like an analog device and the power supply must be well decoupled with a good quality RF 0.01 uF capacitor in parallel with a 0.1 uF capacitor, located as close to pin 14 as possible and connected to ground. In some cases, a PI filter such as a large capacitor (10uF) to ground, a series ferrite bead or inductor with 0.01 uF and 100 pF capacitor to ground to decouple the device supply.

The traces for the OUT1, OUT2, RCLK and RDATA outputs should be kept as short as possible. It is common practice to use a series resistor (50 to 100 ohms) in order to reduce reflections if these traces are more than a couple of inches long. Also OUT1, OUT2, RCLK and RDATA should not be routed directly underneath the device.

The op-amp loop filter components should be kept as close to the device as possible and the feedback capacitor should be located close to the op-amp input terminal. The loop filter capacitor(s) should be low leakage (polarized capacitors are allowed).

Unused outputs should be left floating and it is not required to load or terminate them (such as an ECL or PECL output). Loading unused outputs will only increase current consumption.

Application Circuits

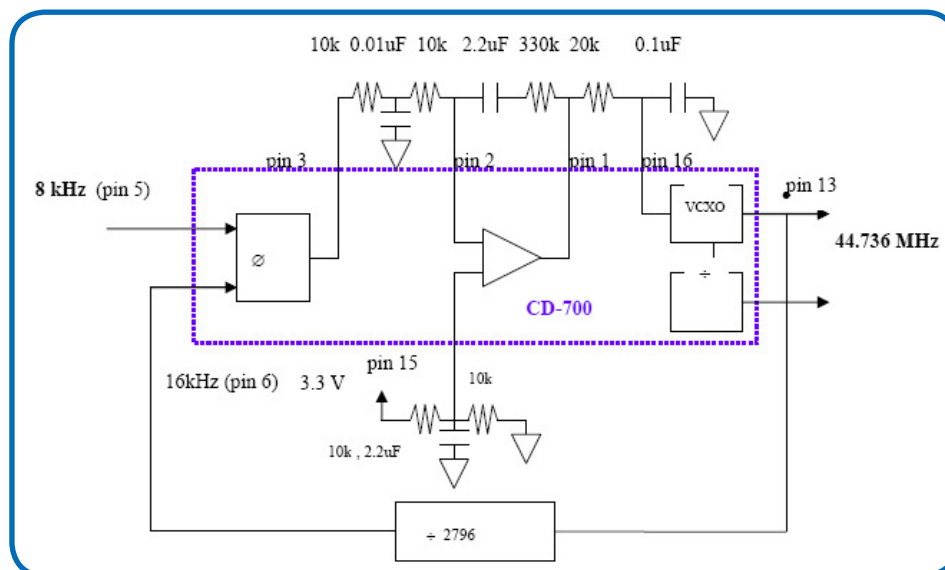

Figure 8. 8kHz to 44.736MHz Frequency Translation

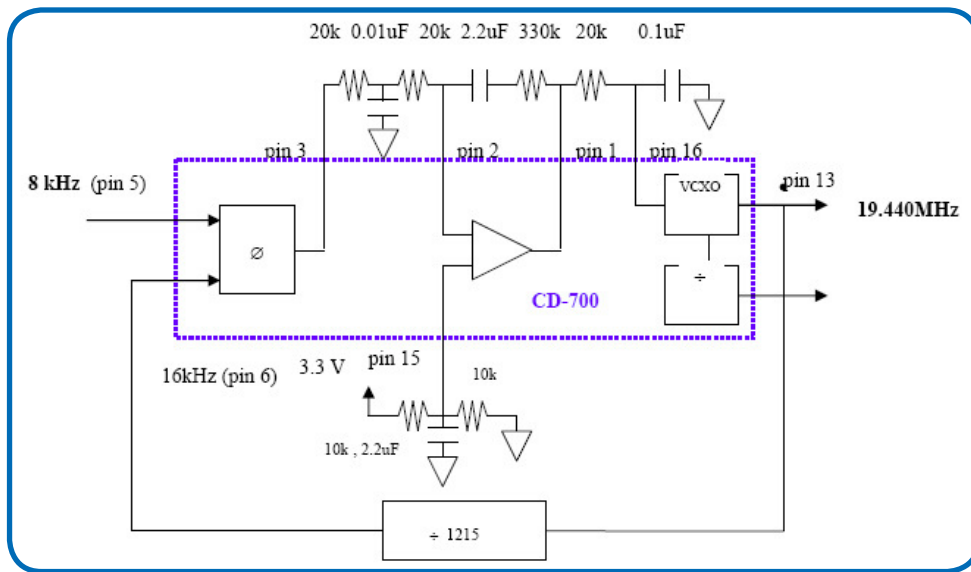

Figure 9. 8kHz to 19.44MHz Frequency Translation

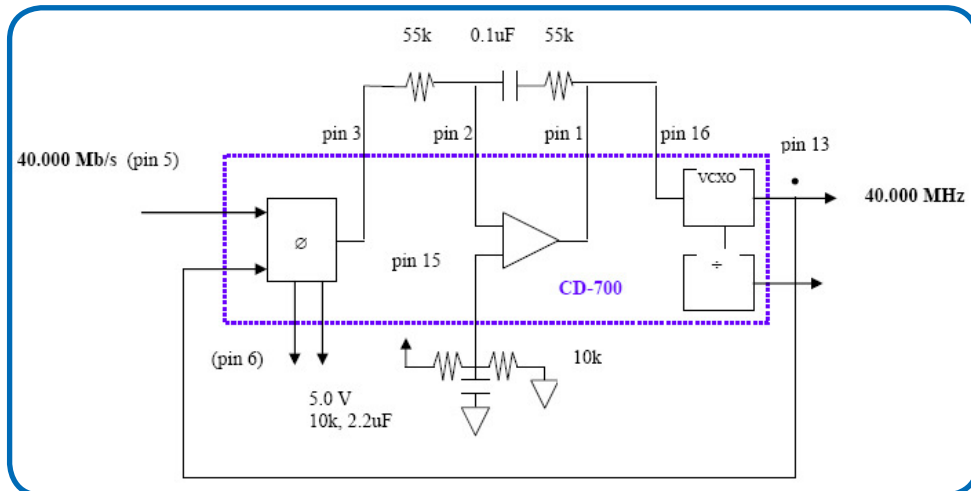

Figure 10. 40.00MHz NRZ Clock Recovery

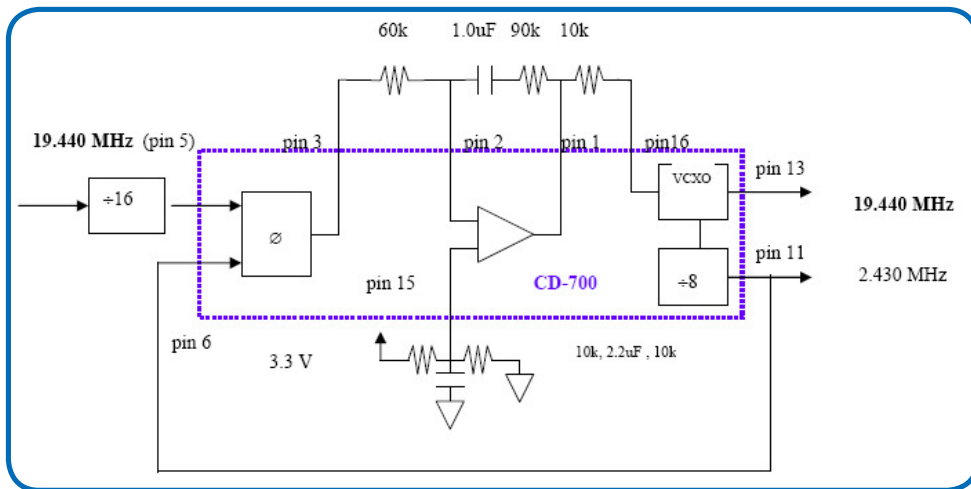

Figure 11. 19.44MHz Clock Smoothing

Table 5. Environmental Compliance

Parameter	Symbol	Value
PreHeat Time	t_s	60 sec Min, 180 sec Max
Ramp Up	R_{UP}	3 °C/sec Max
Time Above 217 oC	t_L	60 sec Min, 150 sec Max
Time To Peak Temperature	t_{AMP-B}	480 sec Max
Time At 260 oC	t_p	20 sec Min, 40 sec Max
Ramp Down	R_{DN}	6 °C/sec Max

The device has been qualified to meet the JEDEC standard for Pb-Free assembly. The temperatures and time intervals listed are based on the Pb-Free small body requirements. The temperatures refer to the topside of the package, measured on the package body surface. The CD-700 device is hermetically sealed so an aqueous wash is not an issue.

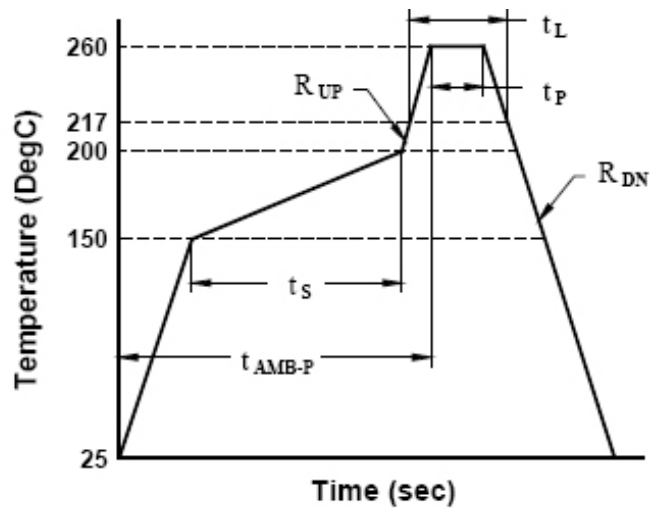

Figure 12. Suggested IR Profile

Tape and Reel

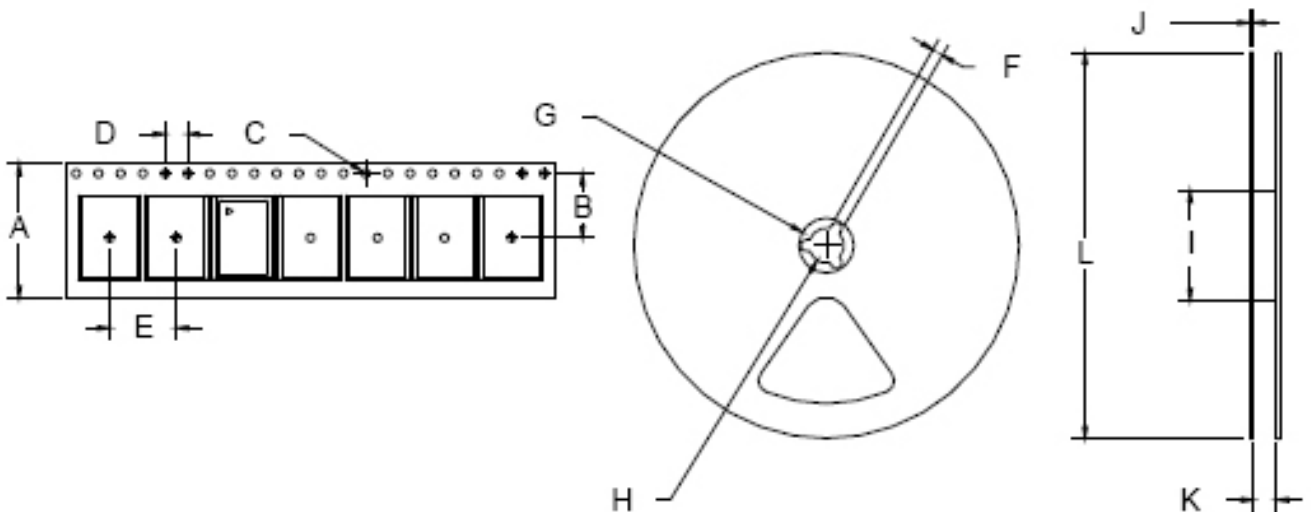

Figure 13. Tape and Reel

Table 6. Tape and Reel Information

Tape Dimensions (mm)					Reel Dimensions (mm)							
A	B	C	D	E	F	G	H	I	J	K	L	#/Reel
16	7.5	1.5	4	8	1.5	20.2	13	50	6	16.4	178	200

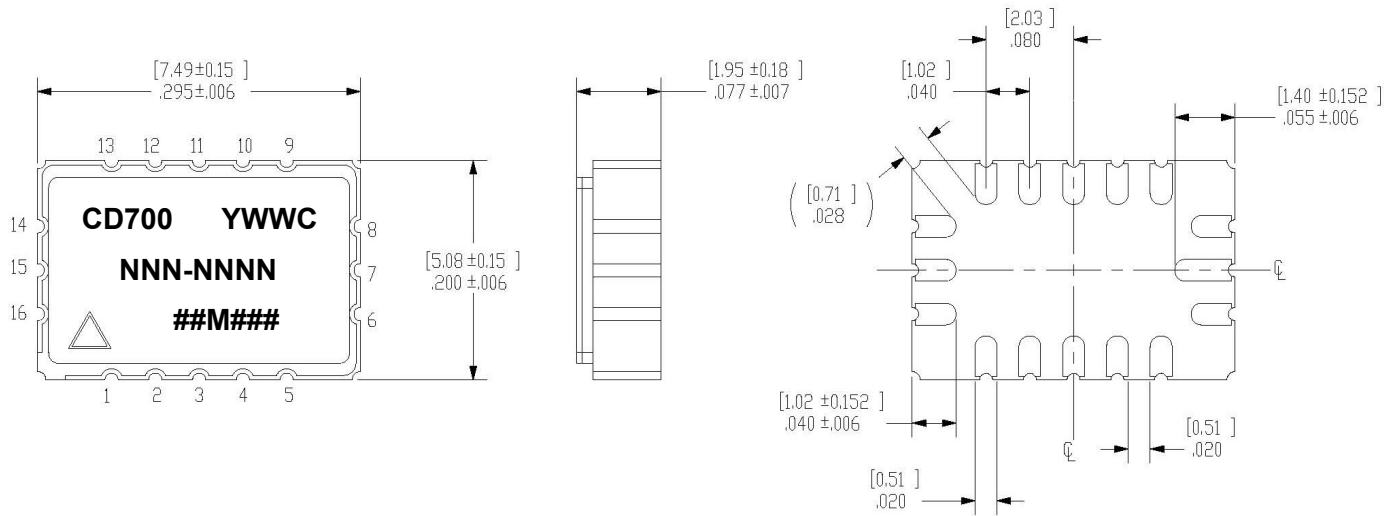

Figure 14. Outline Diagram

Table 7. Pin Functions

Pin	Symbol	Function
1	OPOUT	Op-Amp Output
2	OPN	Op-Amp Negative Input
3	PHO	Phase detector Output
4	LOSIN	INPUT (Used with LOS) Logic 0, VCXO control voltage is enabled. Logic 1, VCXO control voltage (pin 16) is disabled and OUT1 and OUT2 are within +/-75 ppm of center frequency Has Internal pull-down resistor
5	DATAIN	Phase detector Input signal (TTL switching thresholds)
6	CLKIN	Phase detector Clock signal (TTL switching thresholds)
7	GND	Cover and Electrical Ground
8	LOS	OUTPUT (Used with LOSIN) Logic 1 if there are no transitions detected at DATAIN after 256 clock cycles at CLKIN. As soon as a transition occurs at DATAIN, LOS is set to a logic low. Logic 0 = Input frequency detected
9	RCLK	Recovered Clock
10	RDATA	Recovered Data
11	OUT2	Divided-down VCXO Output, or Disabled
12	HIZ	INPUT Logic 0, OUT1, OUT2, RCLK, RDATA are set to a high impedance state. Logic 1, OUT1, OUT2, RCLK, RDATA are active. Has Internal pull-up resistor
13	OUT1	VCXO Output
14	V _{DD}	Power Supply Voltage (3.3 V ± 10% or 5.0 V ± 10%)
15	OPP	Op-Amp Positive Input
16	V _C	VCXO Control Voltage

Table 8. Standard OUT1 Frequencies (MHz)

12M2880000	19M2000000	21M0050840	29M4912000	38M8800000	44M4343000	52M0000000	70M0000000
12M3076860	19M3926580	22M0000000	29M5000000	39M0625000	44M6218000	53M3300000	70M6560000
12M3520000	19M4400000	22M1047720	30M0000000	39M3216000	44M7360000	54M7460000	71M6100000
12M8000000	19M5312500	22M2171000	30M7200000	39M8437500	44M9280000	55M0000000	73M7280000
13M0000000	19M6608000	22M5792000	30M8800000	40M0000000	45M1584000	60M0000000	74M1250000
13M5000000	19M6989680	24M0000000	31M2500000	40M2830630	45M8240000	61M3800000	74M1758000
14M8351600	19M7190000	24M5760000	32M0000000	40M9600000	46M0379460	61M4400000	74M2500000
15M0000000	19M9218750	24M7040000	32M7680000	41M0888870	46M7200000	62M2080000	75M0000000
15M0336000	20M0000000	25M0000000	33M0000000	41M6571440	46M8750000	62M5000000	76M8000000
15M3600000	20M1416000	25M1658000	33M3330000	41M6600000	48M0000000	62M9145000	77M7600000
16M0000000	20M4800000	25M6000000	34M3680000	41M8329130	49M1520000	63M3600000	
16M3840000	20M5444340	25M9200000	34M5600000	42M0000000	49M4080000	63M8976000	
17M1840000	20M7135000	26M0000000	36M8640000	42M0101690	50M0000000	64M0000000	
18M4320000	20M8285720	27M0000000	37M0560000	42M5000000	50M0480000	64M1520000	
18M5280000	20M8286000	27M6480000	37M1250000	42M6600000	51M2000000	65M5360000	

CD - 700 - D A E - K A N N - xxMxxxxxxx

Product Family

CD: Clock and Data Recovery

Package

700: 5.0 x 7.5 x 2.0mm

Input

D: 5.0 Vdc ±10%

E: 3.3 Vdc ±10%

Output

A: CMOS/HCMOS/ACMOS

Operating Temperature

E: -40 to 85 °C

T: 0 to 70 °C

Absolute Pull Range

K: ± 50 ppm

S: ± 100 ppm

Frequency (See Above)

Performance Options

N: Standard

A: Improved Phase Noise

Factory Use

Output 2 Divider

A: Divide by 2

B: Divide by 4

C: Divide by 8

D: Divide by 16

E: Divide by 32

F: Divide by 64

G: Divide by 128

H: Divide by 256

K: Disabled

Note: Not all combinations are available. Check with the factory for the optimum device configuration for your application



Microsemi, a wholly owned subsidiary of Microchip Technology Inc. (Nasdaq: MCHP), offers a comprehensive portfolio of semiconductor and system solutions for aerospace & defense, communications, data center and industrial markets. Products include high-performance and radiation-hardened analog mixed-signal integrated circuits, FPGAs, SoCs and ASICs; power management products; timing and synchronization devices and precise time solutions, setting the world's standard for time; voice processing devices; RF solutions; discrete components; enterprise storage and communication solutions, security technologies and scalable anti-tamper products; Ethernet solutions; Power-over-Ethernet ICs and midspans; as well as custom design capabilities and services. Learn more at www.microsemi.com.

Microsemi Headquarters

One Enterprise, Aliso Viejo, CA 92656 USA

Within the USA: +1 (800) 713-4113

Outside the USA: +1 (949) 380-6100

Sales: +1 (949) 380-6136

Fax: +1 (949) 215-4996

email: sales.support@microsemi.com

www.microsemi.com

Microsemi makes no warranty, representation, or guarantee regarding the information contained herein or the suitability of its products and services for any particular purpose, nor does Microsemi assume any liability whatsoever arising out of the application or use of any product or circuit. The products sold hereunder and any other products sold by Microsemi have been subject to limited testing and should not be used in conjunction with mission-critical equipment or applications. Any performance specifications are believed to be reliable but are not verified, and Buyer must conduct and complete all performance and other testing of the products, alone and together with, or installed in, any end-products. Buyer shall not rely on any data and performance specifications or parameters provided by Microsemi. It is the Buyer's responsibility to independently determine suitability of any products and to test and verify the same. The information provided by Microsemi hereunder is provided "as is, where is" and with all faults, and the entire risk associated with such information is entirely with the Buyer. Microsemi does not grant, explicitly or implicitly, to any party any patent rights, licenses, or any other IP rights, whether with regard to such information itself or anything described by such information. Information provided in this document is proprietary to Microsemi, and Microsemi reserves the right to make any changes to the information in this document or to any products and services at any time without notice.

©2018 Microsemi, a wholly owned subsidiary of Microchip Technology Inc. All rights reserved. Microsemi and the Microsemi logo are registered trademarks of Microsemi Corporation. All other trademarks and service marks are the property of their respective owners.



Компания «ЭлектроПласт» предлагает заключение долгосрочных отношений при поставках импортных электронных компонентов на взаимовыгодных условиях!

Наши преимущества:

- Оперативные поставки широкого спектра электронных компонентов отечественного и импортного производства напрямую от производителей и с крупнейших мировых складов;
- Поставка более 17-ти миллионов наименований электронных компонентов;
- Поставка сложных, дефицитных, либо снятых с производства позиций;
- Оперативные сроки поставки под заказ (от 5 рабочих дней);
- Экспресс доставка в любую точку России;
- Техническая поддержка проекта, помощь в подборе аналогов, поставка прототипов;
- Система менеджмента качества сертифицирована по Международному стандарту ISO 9001;
- Лицензия ФСБ на осуществление работ с использованием сведений, составляющих государственную тайну;
- Поставка специализированных компонентов (Xilinx, Altera, Analog Devices, Intersil, Interpoint, Microsemi, Aeroflex, Peregrine, Syfer, Eurofarad, Texas Instrument, Miteq, Cobham, E2V, MA-COM, Hittite, Mini-Circuits, General Dynamics и др.);

Помимо этого, одним из направлений компании «ЭлектроПласт» является направление «Источники питания». Мы предлагаем Вам помощь Конструкторского отдела:

- Подбор оптимального решения, техническое обоснование при выборе компонента;
- Подбор аналогов;
- Консультации по применению компонента;
- Поставка образцов и прототипов;
- Техническая поддержка проекта;
- Защита от снятия компонента с производства.



Как с нами связаться

Телефон: 8 (812) 309 58 32 (многоканальный)

Факс: 8 (812) 320-02-42

Электронная почта: org@eplast1.ru

Адрес: 198099, г. Санкт-Петербург, ул. Калинина, дом 2, корпус 4, литера А.