

FEATURES:

- **Organized as 64K x8 / 128K x8 / 256K x8**
- **4.5-5.5V Read Operation**
- **Superior Reliability**
 - Endurance: At least 1000 Cycles
 - Greater than 100 years Data Retention
- **Low Power Consumption**
 - Active Current: 20 mA (typical)
 - Standby Current: 10 μ A (typical)
- **Fast Read Access Time**
 - 70 ns
- **Fast Byte-Program Operation**
 - Byte-Program Time: 20 μ s (typical)
 - Chip Program Time:
 - 1.4 seconds (typical) for GLS27SF512
 - 2.8 seconds (typical) for GLS27SF010
 - 5.6 seconds (typical) for GLS27SF020
- **Electrical Erase Using Programmer**
 - Does not require UV source
 - Chip-Erase Time: 100 ms (typical)
- **TTL I/O Compatibility**
- **JEDEC Standard Byte-wide EPROM Pinouts**
- **Packages Available**
 - 32-lead PLCC
 - 32-lead TSOP (8mm x 14mm)
 - 32-pin PDIP for GLS27SF010/020
- **All non-Pb (lead-free) devices are RoHS compliant**

PRODUCT DESCRIPTION

The GLS27SF512/010/020 are a 64K x8 / 128K x8 / 256K x8 CMOS, Many-Time Programmable (MTP) low cost flash, manufactured with high performance SuperFlash technology. The split-gate cell design and thick oxide tunneling injector attain better reliability and manufacturability compared with alternate approaches. These MTP devices can be electrically erased and programmed at least 1000 times using an external programmer with a 12V power supply. They have to be erased prior to programming. These devices conform to JEDEC standard pinouts for byte-wide memories.

Featuring high-performance Byte-Program, the GLS27SF512/010/020 provide a Byte-Program time of 20 μ s. Designed, manufactured, and tested for a wide spectrum of applications, these devices are offered with an endurance of at least 1000 cycles. Data retention is rated at greater than 100 years.

The GLS27SF512/010/020 are suited for applications that require infrequent writes and low power nonvolatile storage. These devices will improve flexibility, efficiency, and performance while matching the low cost in nonvolatile applications that currently use UV-EPROMs, OTPs, and mask ROMs.

To meet surface mount and conventional through hole requirements, the GLS27SF512 are offered in 32-lead PLCC, 32-lead TSOP, and 28-pin PDIP packages. The GLS27SF010/020 are offered in 32-pin PDIP, 32-lead PLCC, and 32-lead TSOP packages. See Figures 3, 4, and 5 for pin assignments.

Device Operation

The GLS27SF512/010/020 are a low cost flash solution that can be used to replace existing UV-EPROM, OTP, and mask ROM sockets. These devices are functionally (read and program) and pin compatible with industry standard EPROM products. In addition to EPROM functionality, these devices also support electrical Erase operation via an external programmer. They do not require a UV source to erase, and therefore the packages do not have a window.

Read

The Read operation of the GLS27SF512/010/020 is controlled by CE# and OE#. Both CE# and OE# have to be low for the system to obtain data from the outputs. Once the address is stable, the address access time is equal to the delay from CE# to output (T_{CE}). Data is available at the output after a delay of T_{OE} from the falling edge of OE#, assuming that CE# pin has been low and the addresses

Data Sheet

have been stable for at least $T_{CE-T_{OE}}$. When the CE# pin is high, the chip is deselected and a typical standby current of 10 μ A is consumed. OE# is the output control and is used to gate data from the output pins. The data bus is in high impedance state when either CE# or OE# is high.

Byte-Program Operation

The GLS27SF512/010/020 are programmed by using an external programmer. The programming mode for GLS27SF010/020 is activated by asserting 11.4-12V on V_{PP} pin, V_{DD} = 4.5-5.5V, V_{IL} on CE# pin, and V_{IH} on OE# pin. The programming mode for GLS27SF512 is activated by asserting 11.4-12V on OE#/V_{PP} pin, V_{DD} = 4.5-5.5V, and V_{IL} on CE# pin. These devices are programmed byte-by-byte with the desired data at the desired address using a single pulse (CE# pin low for GLS27SF512 and PGM# pin low for GLS27SF010/020) of 20 μ s. Using the MTP programming algorithm, the Byte-Programming process continues byte-by-byte until the entire chip has been programmed.

Chip-Erase Operation

The only way to change a data from a “0” to “1” is by electrical erase that changes every bit in the device to “1”. Unlike traditional EPROMs, which use UV light to do the Chip-Erase, the GLS27SF512/010/020 uses an electrical Chip-Erase operation. This saves a significant amount of time (about 30 minutes for each Erase operation). The entire chip can be erased in a single pulse of 100 ms (CE# pin low for GLS27SF512 and PGM# pin for GLS27SF010/020). In order to activate the Erase mode for GLS27SF010/020, the 11.4-12V is applied to V_{PP} and A₉ pins, V_{DD} = 4.5-5.5V, V_{IL} on CE# pin, and V_{IH} on OE# pin. In order to activate Erase mode for GLS27SF512, the 11.4-12V is applied to OE#/V_{PP} and A₉ pins, V_{DD} = 4.5-5.5V, and V_{IL} on CE# pin. All other address and data pins are “don’t care”. The falling edge of CE# (PGM# for GLS27SF010/020) will start the Chip-Erase operation. Once the chip has been erased, all bytes must be verified for FFH. Refer to Figures 13 and 14 for the flowcharts.

Product Identification Mode

The Product Identification mode identifies the devices as the GLS27SF512, GLS27SF010 and GLS27SF020 and manufacturer as Greenliant. This mode may be accessed by the hardware method. To activate this mode for GLS27SF010/020, the programming equipment must force V_H (11.4-12V) on address A₉ with V_{PP} pin at V_{DD} (4.5-5.5V) or V_{SS}. To activate this mode for GLS27SF512, the programming equipment must force V_H (11.4-12V) on address A₉ with OE#/V_{PP} pin at V_{IL}. Two identifier bytes may then be sequenced from the device outputs by toggling address line A₀. For details, see Tables 3 and 4 for hardware operation.

TABLE 1: Product Identification

	Address	Data
Manufacturer's ID	0000H	BFH
Device ID		
GLS27SF512	0001H	A4H
GLS27SF010	0001H	A5H
GLS27SF020	0001H	A6H

T1.2 1152



FIGURE 1: Functional Block Diagram - GLS27SF512

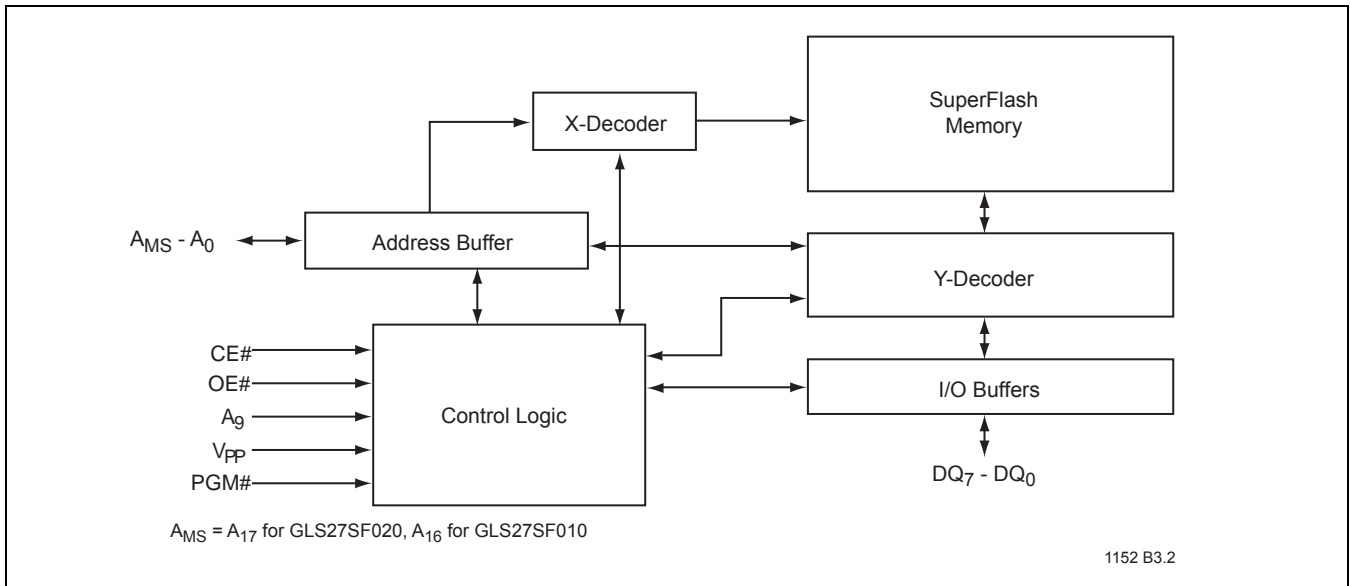

FIGURE 2: Functional Block Diagram - GLS27SF010/020

Data Sheet



FIGURE 3: Pin Assignments for 32-lead PLCC



FIGURE 4: Pin Assignments for 32-lead TSOP (8mm x 14mm)



FIGURE 5: Pin Assignments for 28-pin and 32-pin PDIP

TABLE 2: Pin Description

Symbol	Pin Name	Functions
$A_{MS}^1-A_0$	Address Inputs	To provide memory addresses
DQ7-DQ0	Data Input/output	To output data during Read cycles and receive input data during Program cycles The outputs are in tri-state when OE# or CE# is high.
CE#	Chip Enable	To activate the device when CE# is low
OE#	Output Enable	For GLS27SF010/020, to gate the data output buffers during Read operation
OE#/VPP	Output Enable/VPP	For GLS27SF512, to gate the data output buffers during Read operation and high voltage pin during Chip-Erase and programming operation
VPP	Power Supply for Program or Erase	For GLS27SF010/020, high voltage pin during Chip-Erase and programming operation 11.4-12V
VDD	Power Supply	To provide 5.0V supply (4.5-5.5V)
VSS	Ground	
NC	No Connection	Unconnected pins.

1. A_{MS} = Most significant address
 A_{MS} = A15 for GLS27SF512, A16 for GLS27SF010, and A17 for GLS27SF020

T2.4 1152

Data Sheet

TABLE 3: Operation Modes Selection for GLS27SF512

Mode	CE#	OE#/V _{PP}	A ₉	DQ	Address
Read	V _{IL}	V _{IL}	A _{IN}	D _{OUT}	A _{IN}
Output Disable	V _{IL}	V _{IH}	X ¹	High Z	X
Program	V _{IL}	V _{PPH}	A _{IN}	D _{IN}	A _{IN}
Standby	V _{IH}	X	X	High Z	X
Chip-Erase	V _{IL}	V _{PPH}	V _H	High Z	X
Program/Erase Inhibit	V _{IH}	V _{PPH}	X	High Z	X
Product Identification	V _{IL}	V _{IL}	V _H	Manufacturer's ID (BFH) Device ID (A4H)	A ₁₅ -A ₁ =V _{IL} , A ₀ =V _{IL} A ₁₅ -A ₁ =V _{IL} , A ₀ =V _{IH}

T3.2 1152

 1. X can be V_{IL} or V_{IH}, but no other value.

Note: V_{PPH} = 11.4-12V, V_H = 11.4-12V

TABLE 4: Operation Modes Selection for GLS27SF010/020

Mode	CE#	OE#	PGM#	A ₉	V _{PP}	DQ	Address
Read	V _{IL}	V _{IL}	X ¹	A _{IN}	V _{DD} or V _{SS}	D _{OUT}	A _{IN}
Output Disable	V _{IL}	V _{IH}	X	X	V _{DD} or V _{SS}	High Z	A _{IN}
Program	V _{IL}	V _{IH}	V _{IL}	A _{IN}	V _{PPH}	D _{IN}	A _{IN}
Standby	V _{IH}	X	X	X	V _{DD} or V _{SS}	High Z	X
Chip-Erase	V _{IL}	V _{IH}	V _{IL}	V _H	V _{PPH}	High Z	X
Program/Erase Inhibit	V _{IH}	X	X	X	V _{PPH}	High Z	X
Product Identification	V _{IL}	V _{IL}	X	V _H	V _{DD} or V _{SS}	Manufacturer's ID (BFH) Device ID ²	A _{MS} ³ - A ₁ =V _{IL} , A ₀ =V _{IL} A _{MS} ³ - A ₁ =V _{IL} , A ₀ =V _{IH}

T4.2 1152

 1. X can be V_{IL} or V_{IH}, but no other value.

2. Device ID = A5H for GLS27SF010 and A6H for GLS27SF020

 3. A_{MS} = Most significant address

 A_{MS} = A₁₆ for GLS27SF010 and A₁₇ for GLS27SF020

Note: V_{PPH} = 11.4-12V, V_H = 11.4-12V

Absolute Maximum Stress Ratings (Applied conditions greater than those listed under “Absolute Maximum Stress Ratings” may cause permanent damage to the device. This is a stress rating only and functional operation of the device at these conditions or conditions greater than those defined in the operational sections of this data sheet is not implied. Exposure to absolute maximum stress rating conditions may affect device reliability.)

Temperature Under Bias	-55°C to +125°C
Storage Temperature	-65°C to +150°C
D. C. Voltage on Any Pin to Ground Potential	-0.5V to V _{DD} +0.5V
Transient Voltage (<20 ns) on Any Pin to Ground Potential	-2.0V to V _{DD} +2.0V
Voltage on A ₉ and V _{PP} Pin to Ground Potential	-0.5V to 14.0V
Package Power Dissipation Capability (T _A = 25°C)	1.0W
Through Hole Lead Soldering Temperature (10 Seconds)	300°C
Surface Mount Solder Reflow Temperature ¹	260°C for 10 seconds
Output Short Circuit Current ²	100 mA

1. Excluding certain with-Pb 32-PLCC units, all packages are 260°C capable in both non-Pb and with-Pb solder versions. Certain with-Pb 32-PLCC package types are capable of 240°C for 10 seconds; please consult the factory for the latest information.
2. Outputs shorted for no more than one second. No more than one output shorted at a time.

OPERATING RANGE

Range	Ambient Temp	V _{DD}	V _{PP}
Commercial	0°C to +70°C	4.5-5.5V	11.4-12V

AC CONDITIONS OF TEST

Input Rise/Fall Time	10 ns
Output Load	C _L = 30 pF for 70 ns
See Figures 11 and 12	

TABLE 5: Read Mode DC Operating Characteristics for GLS27SF512/010/020
 V_{DD} = 4.5-5.5V, V_{PP}=V_{DD} or V_{SS} (T_A = 0°C to +70°C (Commercial))

Symbol	Parameter	Limits			Test Conditions
		Min	Max	Units	
I _{DD}	V _{DD} Read Current		30	mA	Address input=V _{ILT} /V _{IHT} at f=1/T _{RC} Min V _{DD} =V _{DD} Max CE#=OE#=V _{IL} , all I/Os open
I _{PPR}	V _{PP} Read Current		100	µA	Address input=V _{ILT} /V _{IHT} at f=1/T _{RC} Min V _{DD} =V _{DD} Max, V _{PP} =V _{DD} CE#=OE#=V _{IL} , all I/Os open
I _{SB1}	Standby V _{DD} Current (TTL input)		3	mA	CE#=V _{IH} , V _{DD} =V _{DD} Max
I _{SB2}	Standby V _{DD} Current (CMOS input)		100	µA	CE#=V _{DD} -0.3 V _{DD} =V _{DD} Max
I _{LI}	Input Leakage Current		1	µA	V _{IN} =GND to V _{DD} , V _{DD} =V _{DD} Max
I _{LO}	Output Leakage Current		10	µA	V _{OUT} =GND to V _{DD} , V _{DD} =V _{DD} Max
V _{IL}	Input Low Voltage		0.8	V	V _{DD} =V _{DD} Min
V _{IH}	Input High Voltage	2.0	V _{DD} +0.5	V	V _{DD} =V _{DD} Max
V _{OL}	Output Low Voltage		0.2	V	I _{OL} =2.1 mA, V _{DD} =V _{DD} Min
V _{OH}	Output High Voltage	2.4		V	I _{OH} =-400 µA, V _{DD} =V _{DD} Min
I _H	Supervoltage Current for A ₉		200	µA	CE#=OE#=V _{IL} , A ₉ =V _H Max

T5.6 1152

Data Sheet

TABLE 6: Program/Erase DC Operating Characteristics for GLS27SF512
 $V_{DD}=4.5-5.5V, V_{PP}=V_{PPH} (T_A=25^{\circ}C\pm 5^{\circ}C)$

Symbol	Parameter	Limits			Test Conditions
		Min	Max	Units	
I_{DD}	V_{DD} Erase or Program Current		30	mA	$CE\#=V_{IL}, OE\#/V_{PP}=11.4-12V, V_{DD}=V_{DD} \text{ Max}$
I_{PP}	V_{PP} Erase or Program Current		3	mA	$CE\#=V_{IL}, OE\#/V_{PP}=11.4-12V, V_{DD}=V_{DD} \text{ Max}$
I_{LI}	Input Leakage Current		1	μA	$V_{IN}=GND \text{ to } V_{DD}, V_{DD}=V_{DD} \text{ Max}$
I_{LO}	Output Leakage Current		10	μA	$V_{OUT}=GND \text{ to } V_{DD}, V_{DD}=V_{DD} \text{ Max}$
V_H	Supervoltage for A_9	11.4	12	V	$CE\#=OE\#/V_{PP}=V_{IL},$
I_H	Supervoltage Current for A_9		200	μA	$CE\#=OE\#/V_{PP}=V_{IL}, A_9=V_H \text{ Max}$
V_{PPH}	High Voltage for $OE\#/V_{PP}$ Pin	11.4	12	V	

T6.5 1152

TABLE 7: Program/Erase DC Operating Characteristics for GLS27SF010/020
 $V_{DD}=4.5-5.5V, V_{PP}=V_{PPH} (T_A=25^{\circ}C\pm 5^{\circ}C)$

Symbol	Parameter	Limits			Test Conditions
		Min	Max	Units	
I_{DD}	V_{DD} Erase or Program Current		30	mA	$CE\#=PGM\#=V_{IL}, OE\#=V_{IH}, V_{PP}=11.4-12V, V_{DD}=V_{DD} \text{ Max}$
I_{PP}	V_{PP} Erase or Program Current		3	mA	$CE\#=PGM\#=V_{IL}, OE\#=V_{IH}, V_{PP}=11.4-12V, V_{DD}=V_{DD} \text{ Max}$
I_{LI}	Input Leakage Current		1	μA	$V_{IN}=GND \text{ to } V_{DD}, V_{DD}=V_{DD} \text{ Max}$
I_{LO}	Output Leakage Current		10	μA	$V_{OUT}=GND \text{ to } V_{DD}, V_{DD}=V_{DD} \text{ Max}$
V_H	Supervoltage for A_9	11.4	12	V	$CE\#=OE\#=V_{IL},$
I_H	Supervoltage Current for A_9		200	μA	$CE\#=OE\#=V_{IL}, A_9=V_H \text{ Max}$
V_{PPH}	High Voltage for V_{PP} Pin	11.4	12	V	

T7.5 1152

TABLE 8: Recommended System Power-up Timings

Symbol	Parameter	Minimum	Units
$T_{PU-READ}^1$	Power-up to Read Operation	100	μs
$T_{PU-WRITE}^1$	Power-up to Write Operation	100	μs

T8.1 1152

1. This parameter is measured only for initial qualification and after a design or process change that could affect this parameter.

TABLE 9: Capacitance ($T_A = 25^{\circ}C, f=1 \text{ Mhz}$, other pins open)

Parameter	Description	Test Condition	Maximum
$C_{I/O}^1$	I/O Pin Capacitance	$V_{I/O} = 0V$	12 pF
C_{IN}^1	Input Capacitance	$V_{IN} = 0V$	6 pF

T9.0 1152

1. This parameter is measured only for initial qualification and after a design or process change that could affect this parameter.

TABLE 10: Reliability Characteristics

Symbol	Parameter	Minimum Specification	Units	Test Method
N_{END}^1	Endurance	1000	Cycles	JEDEC Standard A117
T_{DR}^1	Data Retention	100	Years	JEDEC Standard A103

T10.3 1152

1. This parameter is measured only for initial qualification and after a design or process change that could affect this parameter.

AC CHARACTERISTICS

TABLE 11: Read Cycle Timing Parameters $V_{DD} = 4.5-5.5V$ ($T_A = 0^\circ C$ to $+70^\circ C$ (Commercial))

Symbol	Parameter	Min	Max	Units
T_{RC}	Read Cycle Time	70		ns
T_{CE}	Chip Enable Access Time		70	ns
T_{AA}	Address Access Time		70	ns
T_{OE}	Output Enable Access Time		35	ns
T_{CLZ}^1	CE# Low to Active Output	0		ns
T_{OLZ}^1	OE# Low to Active Output	0		ns
T_{CHZ}^1	CE# High to High-Z Output		25	ns
T_{OHZ}^1	OE# High to High-Z Output		25	ns
T_{OH}^1	Output Hold from Address Change	0		ns

T11.3 1152

1. This parameter is measured only for initial qualification and after a design or process change that could affect this parameter.

TABLE 12: Program/Erase Cycle Timing Parameters for GLS27SF512

Symbol	Parameter	Min	Max	Units
T_{AS}	Address Setup Time	1		μs
T_{AH}	Address Hold Time	1		μs
T_{PRT}	OE#/V _{PP} Pulse Rise Time	50		ns
T_{VPS}	OE#/V _{PP} Setup Time	1		μs
T_{VPH}	OE#/V _{PP} Hold Time	1		μs
T_{PW}	CE# Program Pulse Width	20	30	μs
T_{EW}	CE# Erase Pulse Width	100	500	ms
T_{DS}	Data Setup Time	1		μs
T_{DH}	Data Hold Time	1		μs
T_{VR}	OE#/V _{PP} and A ₉ Recovery Time	1		μs
T_{ART}	A ₉ Rise Time to 12V during Erase	50		ns
T_{A9S}	A ₉ Setup Time during Erase	1		μs
T_{A9H}	A ₉ Hold Time during Erase	1		μs

T12.0 1152

Data Sheet

TABLE 13: Program/Erase Cycle Timing Parameters for GLS27SF010/020

Symbol	Parameter	Min	Max	Units
T _{CES}	CE# Setup Time	1		μs
T _{CEH}	CE# Hold Time	1		μs
T _{AS}	Address Setup Time	1		μs
T _{AH}	Address Hold Time	1		μs
T _{PRT}	V _{PP} Pulse Rise Time	50		ns
T _{VPS}	V _{PP} Setup Time	1		μs
T _{VPH}	V _{PP} Hold Time	1		μs
T _{PW}	PGM# Program Pulse Width	20	30	μs
T _{EW}	PGM# Erase Pulse Width	100	500	ms
T _{DS}	Data Setup Time	1		μs
T _{DH}	Data Hold Time	1		μs
T _{VR}	A ₉ Recovery Time for Erase	1		μs
T _{ART}	A ₉ Rise Time to 12V during Erase	50		ns
T _{A9S}	A ₉ Setup Time during Erase	1		μs
T _{A9H}	A ₉ Hold Time during Erase	1		μs

T13.0 1152



FIGURE 6: Read Cycle Timing Diagram for GLS27SF512/010/020

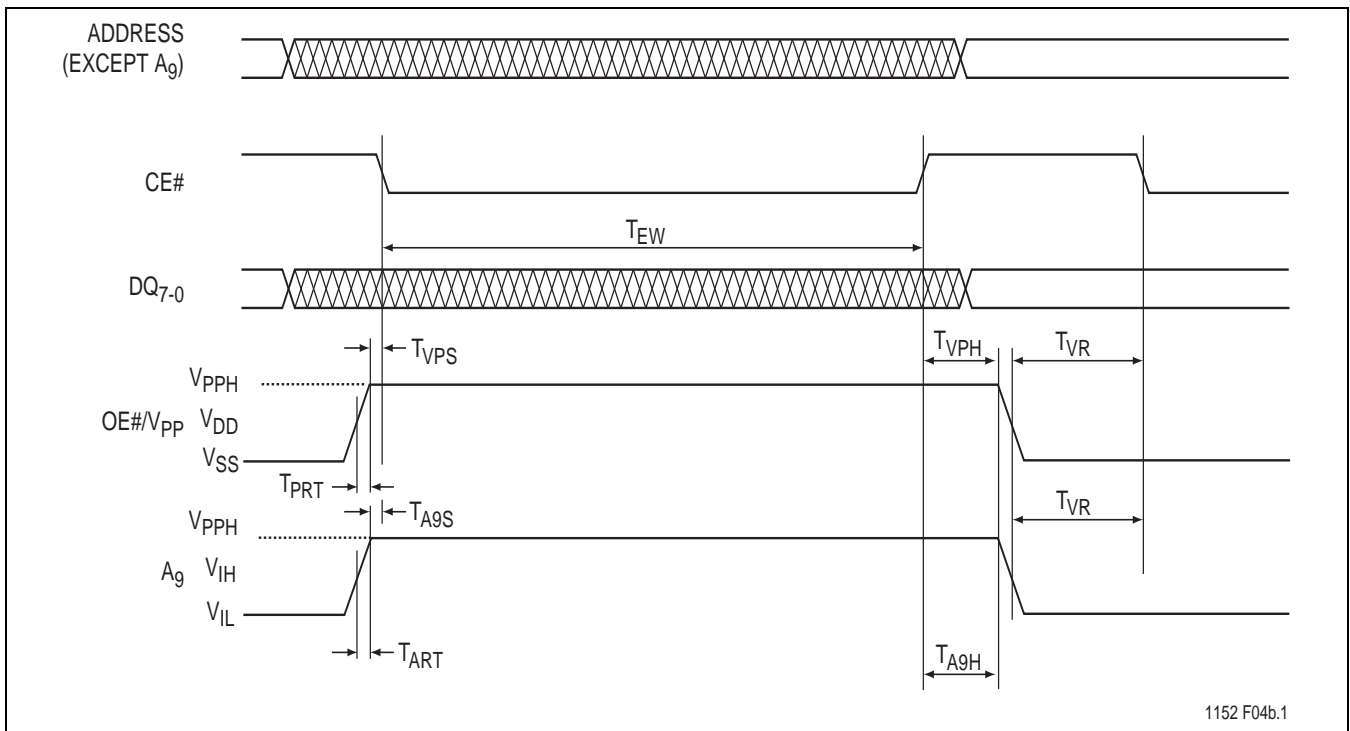

FIGURE 7: Chip-Erase Timing Diagram for GLS27SF512

Data Sheet

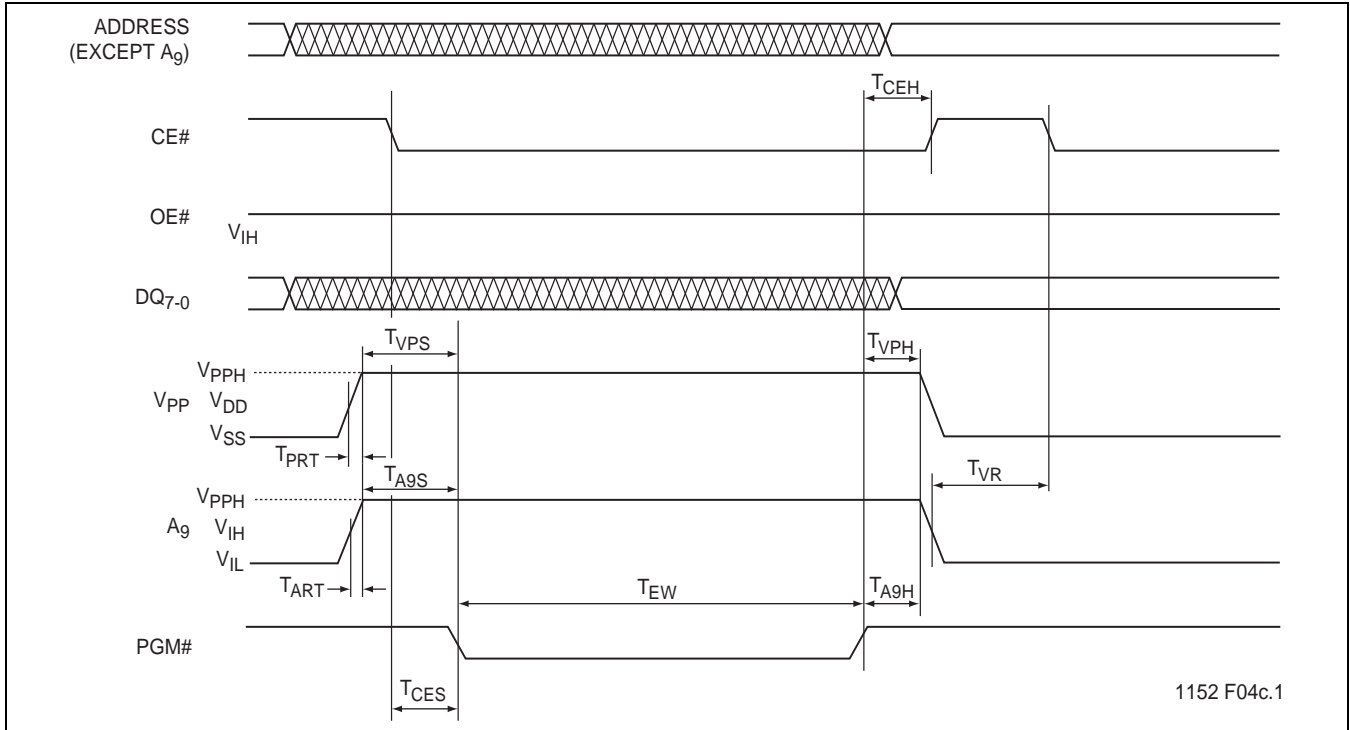

FIGURE 8: Chip-Erase Timing Diagram for GLS27SF010/020

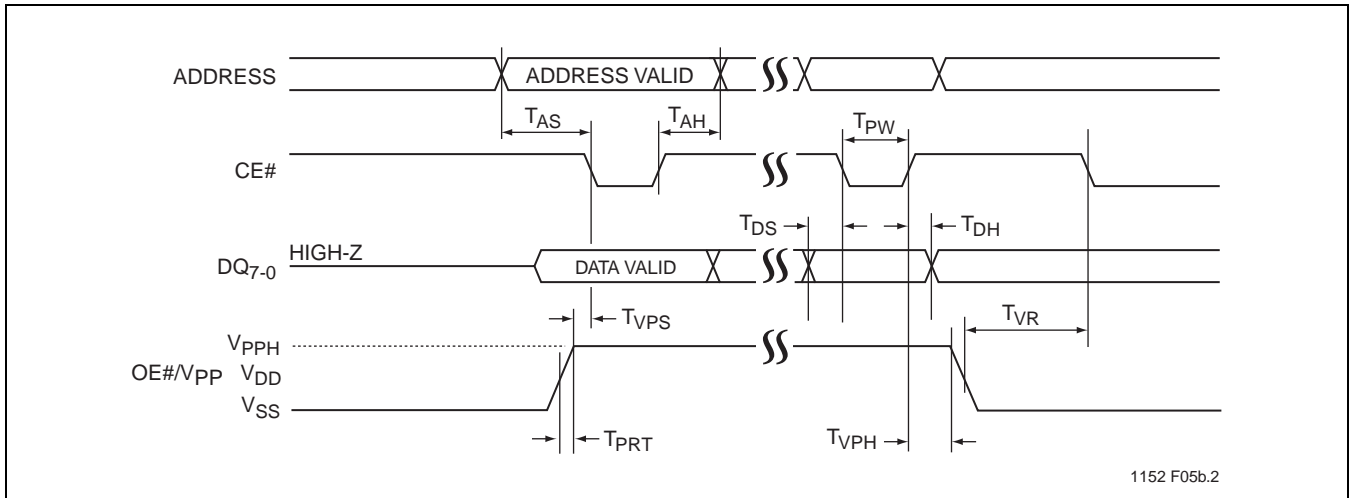

FIGURE 9: Byte-Program Timing Diagram for GLS27SF512

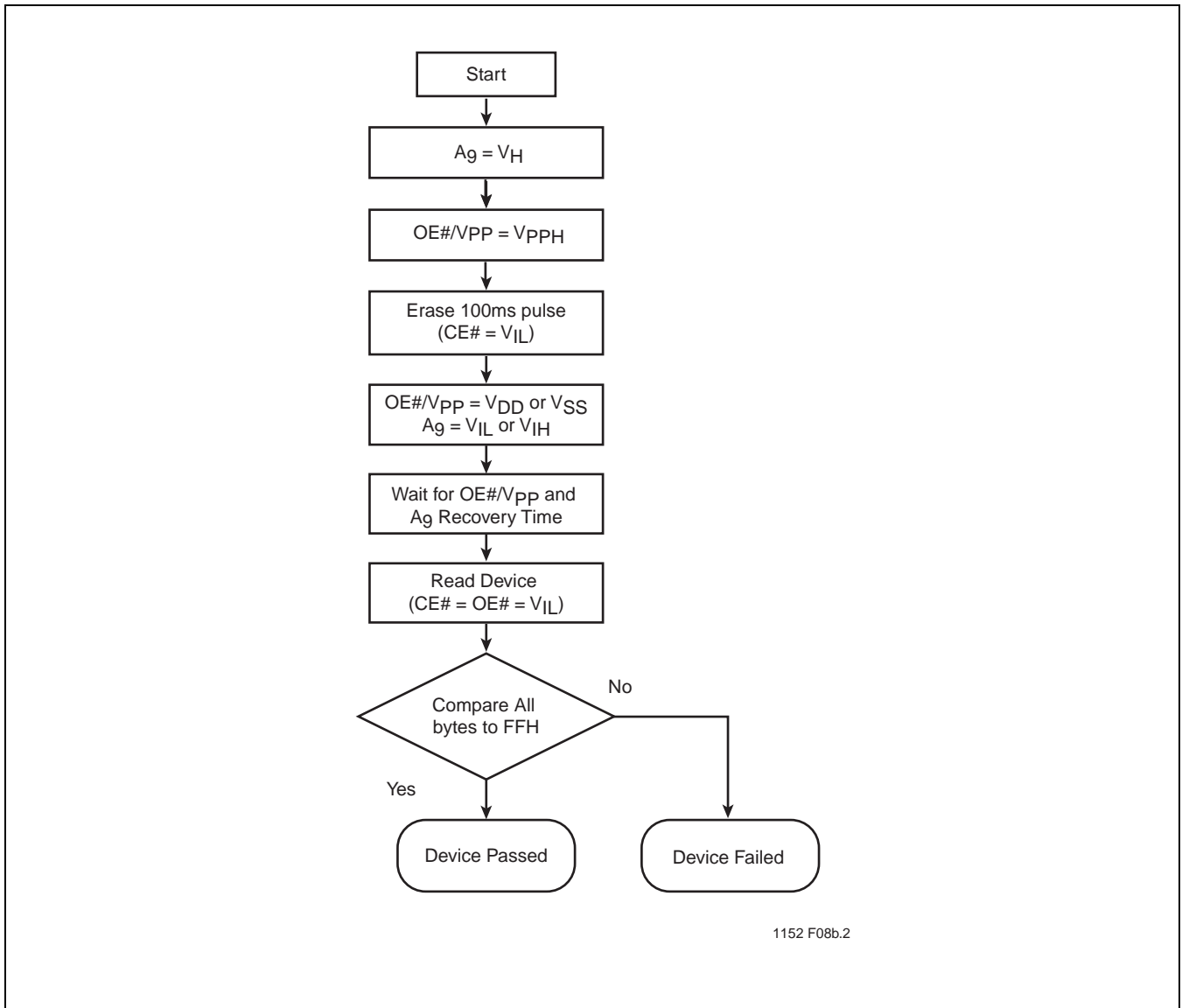

FIGURE 10: Byte-Program Timing Diagram for GLS27SF010/020

Data Sheet

FIGURE 11: AC Input/Output Reference Waveforms

FIGURE 12: A Test Load Example



1152 F08b.2

FIGURE 13: Chip-Erase Algorithm for GLS27SF512



FIGURE 14: Chip-Erase Algorithm for GLS27SF010/020



FIGURE 15: Byte-Program Algorithm for GLS27SF512

FIGURE 16: Byte-Program Algorithm for GLS27SF010/020

PRODUCT ORDERING INFORMATION



1. Environmental suffix "E" denotes non-Pb solder. Greenliant non-Pb solder devices are "RoHS Compliant".

Valid combinations for GLS27SF512

GLS27SF512-70-3C-NHE GLS27SF512-70-3C-WHE

Valid combinations for GLS27SF010

GLS27SF010-70-3C-NHE GLS27SF010-70-3C-WHE GLS27SF010-70-3C-PHE

Valid combinations for GLS27SF020

GLS27SF020-70-3C-NHE GLS27SF020-70-3C-WHE GLS27SF020-70-3C-PHE

Note: Valid combinations are those products in mass production or will be in mass production. Consult your Greenliant sales representative to confirm availability of valid combinations and to determine availability of new combinations.

Data Sheet

PACKAGING DIAGRAMS

FIGURE 17: 32-lead Plastic Lead Chip Carrier (PLCC)
Greenliant Package Code: NH



**FIGURE 18: 32-lead Thin Small Outline Package (TSOP) 8mm x 14mm
 Greenliant Package Code: WH**

Data Sheet



FIGURE 19: 32-pin Plastic Dual In-line Pins (PDIP)
Greenliant Package Code: PH

TABLE 14: Revision History

Number	Description	Date
02	• 2002 Data Book	Feb 2002
03	• Document Control Release (SST Internal): No technical changes	Apr 2002
04	• Corrected I _H Supervoltage Current for A ₉ from 100 μA to 200 μA in Tables 5, 6, and 7	Jul 2002
05	• Corrected the Test Conditions for I _{DD} and I _{PPR} in Table 5 on page 7	Sep 2003
06	• Corrected the Max value for I _{PP} from 1 mA to 3 mA (See Tables 6 and 7) • Added MPNs for non-PB packages (See page 19)	Nov 2003
07	• 2004 Data Book • Corrected caption for Figure 7 from “Read Cycle” to “Chip-Erase”	Nov 2003
08	• Removed 256 Kbit parts - refer to EOL Product Data Sheet S71152(02)	Apr 2004
09	• Removed all 90 ns parts - refer to EOL Product Data Sheet S71152(03) • Added RoHS compliance information on page 1 and in the “Product Ordering Information” on page 19 • Added the solder reflow temperature to the “Absolute Maximum Stress Ratings” on page 7.	Mar 2005
10	• Removed obsolete Latch-up parameter from Table 10 on page 8	May 2005
11	• Corrected V _{PP} voltage from 11.4-12.6V to 11.4-12V	Sep 2005
12	• Removed leaded parts. See S71152(04) • End-of-Life PG package and PG valid combination. See S71152(04)	Sep 2008
13	• Transferred from SST to Greenliant	May 2010

© 2010 Greenliant Systems, Ltd. All rights reserved.

Greenliant, the Greenliant logo and NANDrive are trademarks of Greenliant Systems, Ltd.

All trademarks and registered trademarks are the property of their respective owners.

These specifications are subject to change without notice.

MTP is a trademark and SuperFlash is a registered trademark of Silicon Storage Technology, Inc., a wholly owned subsidiary of Microchip Technology Inc.



Компания «ЭлектроПласт» предлагает заключение долгосрочных отношений при поставках импортных электронных компонентов на взаимовыгодных условиях!

Наши преимущества:

- Оперативные поставки широкого спектра электронных компонентов отечественного и импортного производства напрямую от производителей и с крупнейших мировых складов;
- Поставка более 17-ти миллионов наименований электронных компонентов;
- Поставка сложных, дефицитных, либо снятых с производства позиций;
- Оперативные сроки поставки под заказ (от 5 рабочих дней);
- Экспресс доставка в любую точку России;
- Техническая поддержка проекта, помощь в подборе аналогов, поставка прототипов;
- Система менеджмента качества сертифицирована по Международному стандарту ISO 9001;
- Лицензия ФСБ на осуществление работ с использованием сведений, составляющих государственную тайну;
- Поставка специализированных компонентов (Xilinx, Altera, Analog Devices, Intersil, Interpoint, Microsemi, Aeroflex, Peregrine, Syfer, Eurofarad, Texas Instrument, Miteq, Cobham, E2V, MA-COM, Hittite, Mini-Circuits, General Dynamics и др.);

Помимо этого, одним из направлений компании «ЭлектроПласт» является направление «Источники питания». Мы предлагаем Вам помощь Конструкторского отдела:

- Подбор оптимального решения, техническое обоснование при выборе компонента;
- Подбор аналогов;
- Консультации по применению компонента;
- Поставка образцов и прототипов;
- Техническая поддержка проекта;
- Защита от снятия компонента с производства.



Как с нами связаться

Телефон: 8 (812) 309 58 32 (многоканальный)

Факс: 8 (812) 320-02-42

Электронная почта: org@eplast1.ru

Адрес: 198099, г. Санкт-Петербург, ул. Калинина, дом 2, корпус 4, литера А.