

Miniature Amplified Low Pressure Sensors

Low Pressure (0.5" H₂O to 30 " H₂O) Sensors



Features

- 0 to 0.5" H₂O to 0 to 30" H₂O Pressure Ranges
- Temperature Compensated
- Calibrated Zero and Span

Applications

- Medical Instrumentation
- Environmental Controls
- HVAC

General Description

The Miniature Amplified Output pressure sensor is based upon a proprietary technology to reduce all output offset or common mode errors. This model provides a calibrated amplified output with superior output offset characteristics. Output offset errors due to change in temperature, stability to warm-up, stability to long time period, and position sensitivity are all significantly reduced when compared to conventional compensation methods. In addition the sensor utilizes a silicon, micromachined, stress concentration enhanced structure to provide a very linear output to measured pressure.

These calibrated and temperature compensated sensors give an accurate and stable output over a wide temperature range. This series is intended for use with non-corrosive, non-ionic working fluids such as air, dry gases and the like.

The output of the device is ratiometric to the supply voltage and operation from any D.C. supply voltage between 4.5 and 5.5

Physical Dimensions

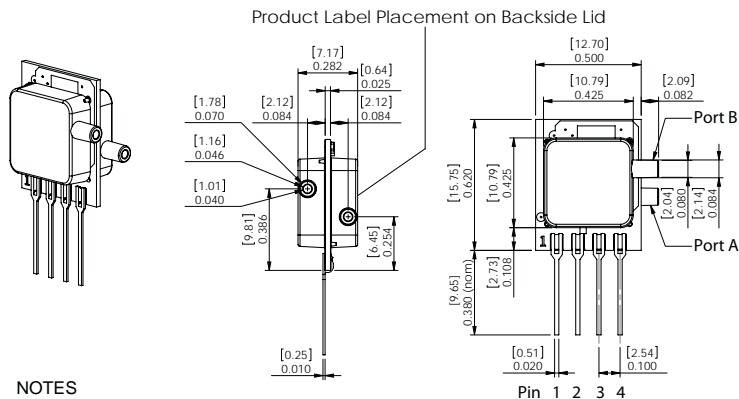

Equivalent Circuit

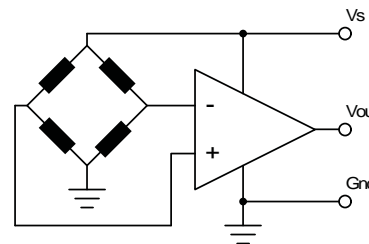

D1 version, D2 version, G version

- Pin 1: Vs**
- Pin 2: Gnd**
- Pin 3: Vout**
- Pin 4: Do Not Connect**

Approvals

MKT	DATE	MFG	DATE	ENG	DATE	QA	DATE
<input type="checkbox"/> As Is <input type="checkbox"/> With Change		<input type="checkbox"/> As Is <input type="checkbox"/> With Change		<input type="checkbox"/> As Is <input type="checkbox"/> With Change		<input type="checkbox"/> As Is <input type="checkbox"/> With Change	

All Sensors

DS-0101 Rev B



Pressure Sensor Characteristics Maximum Ratings

Supply Voltage, V_s	+4.5 to +5.5 Vdc
Common-mode pressure	10 psig
Lead Temperature (soldering 2-4 sec.)	250°C

Environmental Specifications

Temperature Ranges	
Compensated	5 to 50° C
Operating	-25 to 85° C
Storage	-40 to 125° C
Humidity Limits	0 to 95% RH (non condensing)

Standard Pressure Ranges

Part Number	Operating Pressure	Nominal Span	Proof Pressure	Burst Pressure
0.5 INCH-Dx-4V-MINI	± 0.5 inH2O	4 V	100 inH2O	200 inH2O
1 INCH-Dx-4V-MINI	±1 inH2O	4 V	100 inH2O	200 inH2O
1 INCH-G-4V-MINI	0 - 1 inH2O	4 V	100 inH2O	200 inH2O
5 INCH-Dx-4V-MINI	± 5 inH2O	4 V	200 inH2O	300 inH2O
5 INCH-G-4V-MINI	0 - 5 inH2O	4 V	200 inH2O	300 inH2O
10 INCH-Dx-4V-MINI	±10 inH2O	4 V	200 inH2O	300 inH2O
10 INCH-G-4V-MINI	0 - 10 inH2O	4 V	200 inH2O	300 inH2O
20 INCH-Dx-4V-MINI	±20 inH2O	4 V	300 inH2O	500 inH2O
20 INCH-G-4V-MINI	0 - 20 inH2O	4 V	300 inH2O	500 inH2O
30 INCH-Dx-4V-MINI	±30 inH2O	4 V	500 inH2O	800 inH2O
30 INCH-G-4V-MINI	0 - 30 inH2O	4 V	500 inH2O	800 inH2O

For differential pressure D1 is the package with two pressure ports the same side, D2 has two ports the opposite sides.

Performance Characteristics for 0.5 INCH-Dx-4V-MINI

Parameter, note 1	Minimum	Nominal	Maximum	Units
Operating Range, differential pressure	-	±0.5	-	inH2O
Output Span, note 5	±1.90	±2.0	±2.10	V
Offset Voltage @ zero differential pressure	2.15	2.25	2.35	V
Offset Temperature Shift (5°C-50°C), note 2	-	-	±120	mV
Offset Warm-up Shift, note 3	-	±10	-	mV
Offset Position Sensitivity (±1g)	-	±5	-	mV
Offset Long Term Drift (one year)	-	±10	-	mV
Linearity, hysteresis error, note 4	-	0.05	0.25	%FSS
Span Shift (5°C-50°C), note 2	-	-	±2	%FSS

Performance Characteristics for 1 INCH-Dx-4V-MINI

Parameter, note 1	Minimum	Nominal	Maximum	Units
Operating Range, differential pressure	-	±1.0	-	inH2O
Output Span, note 5	±1.90	±2.0	±2.10	V
Offset Voltage @ zero differential pressure	2.15	2.25	2.35	V
Offset Temperature Shift (5°C-50°C), note 2	-	-	±60	mV
Offset Warm-up Shift, note 3	-	±10	-	mV
Offset Position Sensitivity (±1g)	-	±5	-	mV
Offset Long Term Drift (one year)	-	±10	-	mV
Linearity, hysteresis error, note 4	-	0.05	0.25	%FSS
Span Shift (5°C-50°C), note 2	-	-	±2	%FSS

Performance Characteristics for 1 INCH-G-4V-MINI

Parameter, note 1	Minimum	Nominal	Maximum	Units
Operating Range, gage pressure	-	1.0	-	inH2O
Output Span, note 5	3.90	4.0	4.10	V
Offset Voltage @ zero pressure	0.15	0.25	0.35	V
Offset Temperature Shift (5°C-50°C), note 2	-	-	±60	mV
Offset Warm-up Shift, note 3	-	±10	-	mV
Offset Position Sensitivity (±1g)	-	±5	-	mV
Offset Long Term Drift (one year)	-	±10	-	mV
Linearity, hysteresis error, note 4	-	0.05	0.25	%FSS
Span Shift (5°C-50°C), note 2	-	-	±2	%FSS

Performance Characteristics for 5 INCH-Dx-4V-MINI

Parameter, note 1	Minimum	Nominal	Maximum	Units
Operating Range, differential pressure	-	±5.0	-	inH2O
Output Span, note 5	±1.90	±2.0	±2.10	V
Offset Voltage @ zero differential pressure	2.15	2.25	2.35	V
Offset Temperature Shift (5°C-50°C), note 2	-	-	±40	mV
Offset Warm-up Shift, note 3	-	±5	-	mV
Offset Position Sensitivity (±1g)	-	±5	-	mV
Offset Long Term Drift (one year)	-	±5	-	mV
Linearity, hysteresis error, note 4	-	0.05	0.25	%FSS
Span Shift (5°C-50°C), note 2	-	-	±1	%FSS



Performance Characteristics for: 5 INCH-G-4V-MINI

Parameter, NOTE 1	Minimum	Nominal	Maximum	Units
Operating Range, gage pressure	-	5.0	-	inH2O
Output Span, NOTE 5	3.90	4.0	4.10	V
Offset Voltage @ zero pressure	0.15	0.25	0.35	V
Offset Temperature Shift (5°C-50°C), NOTE 2	-	-	±40	mV
Offset Warm-up Shift, NOTE 3	-	±5	-	mV
Offset Position Sensitivity (±1g)	-	±5	-	mV
Offset Long Term Drift (one year)	-	±5	-	mV
Linearity, hysteresis error, NOTE 4	-	0.05	0.25	%FSS
Span Shift (5°C-50°C), NOTE 2	-	-	±1	%FSS

Performance Characteristics for: 10 INCH-Dx-4V-MINI

Parameter, NOTE 1	Minimum	Nominal	Maximum	Units
Operating Range, differential pressure	-	±10.0	-	inH2O
Output Span, NOTE 5	±1.90	±2.0	±2.10	V
Offset Voltage @ zero differential pressure	2.15	2.25	2.35	V
Offset Temperature Shift (5°C-50°C), NOTE 2	-	-	±20	mV
Offset Warm-up Shift, NOTE 3	-	±5	-	mV
Offset Position Sensitivity (±1g)	-	±5	-	mV
Offset Long Term Drift (one year)	-	±5	-	mV
Linearity, hysteresis error, NOTE 4	-	0.05	0.25	%FSS
Span Shift (5°C-50°C), NOTE 2	-	-	±1	%FSS

Performance Characteristics for: 10 INCH-G-4V-MINI

Parameter, NOTE 1	Minimum	Nominal	Maximum	Units
Operating Range, gage pressure	-	10.0	-	inH2O
Output Span, NOTE 5	3.90	4.0	4.10	V
Offset Voltage @ zero pressure	0.15	0.25	0.35	V
Offset Temperature Shift (5°C-50°C), NOTE 2	-	-	±20	mV
Offset Warm-up Shift, NOTE 3	-	±5	-	mV
Offset Position Sensitivity (±1g)	-	±5	-	mV
Offset Long Term Drift (one year)	-	±5	-	mV
Linearity, hysteresis error, NOTE 4	-	0.05	0.25	%FSS
Span Shift (5°C-50°C), NOTE 2	-	-	±1	%FSS

Performance Characteristics for 20 INCH-Dx-4V-MINI

Parameter, note 1	Minimum	Nominal	Maximum	Units
Operating Range, differential pressure	-	±20.0	-	inH2O
Output Span, note 5	±1.90	±2.0	±2.10	V
Offset Voltage @ zero differential pressure	2.15	2.25	2.35	V
Offset Temperature Shift (5°C-50°C), note 2	-	-	±20	mV
Offset Warm-up Shift, note 3	-	±5	-	mV
Offset Position Sensitivity (±1g)	-	±5	-	mV
Offset Long Term Drift (one year)	-	±5	-	mV
Linearity, hysteresis error, note 4	-	0.05	0.25	%FSS
Span Shift (5°C-50°C), note 2	-	-	±1	%FSS

Performance Characteristics for 20 INCH-G-4V-MINI

Parameter, note 1	Minimum	Nominal	Maximum	Units
Operating Range, gage pressure	-	20.0	-	inH2O
Output Span, note 5	3.90	4.0	4.1	V
Offset Voltage @ zero pressure	0.15	0.25	0.35	V
Offset Temperature Shift (5°C-50°C), note 2	-	-	±20	mV
Offset Warm-up Shift, note 3	-	±5	-	mV
Offset Position Sensitivity (±1g)	-	±5	-	mV
Offset Long Term Drift (one year)	-	±5	-	mV
Linearity, hysteresis error, note 4	-	0.05	0.25	%FSS
Span Shift (5°C-50°C), note 2	-	-	±1	%FSS

Performance Characteristics for 30 INCH-Dx-4V-MINI

Parameter, note 1	Minimum	Nominal	Maximum	Units
Operating Range, differential pressure	-	±30.0	-	inH2O
Output Span, note 5	±1.90	±2.0	±2.10	V
Offset Voltage @ zero differential pressure	2.15	2.25	2.35	V
Offset Temperature Shift (5°C-50°C), note 2	-	-	±20	mV
Offset Warm-up Shift, note 3	-	±5	-	mV
Offset Position Sensitivity (±1g)	-	±5	-	mV
Offset Long Term Drift (one year)	-	±5	-	mV
Linearity, hysteresis error, note 4	-	0.05	0.25	%FSS
Span Shift (5°C-50°C), note 2	-	-	±1	%FSS



Performance Characteristics for 30 INCH-G-4V-MINI

Parameter, NOTE 1	Minimum	Nominal	Maximum	Units
Operating Range, gage pressure	-	30.0	-	inH2O
Output Span, NOTE 5	3.9	4.0	4.1	V
Offset Voltage @ zero pressure	0.15	0.25	0.35	V
Offset Temperature Shift (5°C-50°C), NOTE 2	-	-	±20	mV
Offset Warm-up Shift, NOTE 3	-	±5	-	mV
Offset Position Sensitivity (±1g)	-	±5	-	mV
Offset Long Term Drift (one year)	-	±5	-	mV
Linearity, hysteresis error, NOTE 4	-	0.05	0.25	%FSS
Span Shift (5°C-50°C), NOTE 2	-	-	±1	%FSS

Pressure Response: for any pressure applied the response time to get to 90% of pressure applied is typically less than 500 useconds.

Specification Notes

NOTE 1: ALL PARAMETERS ARE MEASURED AT 5.0 VOLT EXCITATION, FOR THE NOMINAL FULL SCALE PRESSURE AND ROOM TEMPERATURE UNLESS OTHERWISE SPECIFIED.

PRESSURE MEASUREMENTS ARE WITH POSITIVE PRESSURE APPLIED TO THE B-PORT.

NOTE 2: SHIFT IS RELATIVE TO 25°C.

NOTE 3: SHIFT IS WITHIN THE FIRST HOUR OF EXCITATION APPLIED TO THE DEVICE.

NOTE 4: MEASURED AT ONE-HALF FULL SCALE RATED PRESSURE USING BEST STRAIGHT LINE CURVE FIT.

NOTE 5: THE VOLTAGE ADDED TO THE OFFSET VOLTAGE AT FULL SCALE PRESSURE. NOMINALLY THE OUTPUT VOLTAGE RANGE IS 0.25 TO 4.25 VOLTS FOR MINUS TO PLUS FULL SCALE PRESSURE.

All Sensors reserves the right to make changes to any products herein. All Sensors does not assume any liability arising out of the application or use of any product or circuit described herein, neither does it convey any license under its patent rights nor the rights of others.



Компания «ЭлектроПласт» предлагает заключение долгосрочных отношений при поставках импортных электронных компонентов на взаимовыгодных условиях!

Наши преимущества:

- Оперативные поставки широкого спектра электронных компонентов отечественного и импортного производства напрямую от производителей и с крупнейших мировых складов;
- Поставка более 17-ти миллионов наименований электронных компонентов;
- Поставка сложных, дефицитных, либо снятых с производства позиций;
- Оперативные сроки поставки под заказ (от 5 рабочих дней);
- Экспресс доставка в любую точку России;
- Техническая поддержка проекта, помощь в подборе аналогов, поставка прототипов;
- Система менеджмента качества сертифицирована по Международному стандарту ISO 9001;
- Лицензия ФСБ на осуществление работ с использованием сведений, составляющих государственную тайну;
- Поставка специализированных компонентов (Xilinx, Altera, Analog Devices, Intersil, Interpoint, Microsemi, Aeroflex, Peregrine, Syfer, Eurofarad, Texas Instrument, Miteq, Cobham, E2V, MA-COM, Hittite, Mini-Circuits, General Dynamics и др.);

Помимо этого, одним из направлений компании «ЭлектроПласт» является направление «Источники питания». Мы предлагаем Вам помощь Конструкторского отдела:

- Подбор оптимального решения, техническое обоснование при выборе компонента;
- Подбор аналогов;
- Консультации по применению компонента;
- Поставка образцов и прототипов;
- Техническая поддержка проекта;
- Защита от снятия компонента с производства.



Как с нами связаться

Телефон: 8 (812) 309 58 32 (многоканальный)

Факс: 8 (812) 320-02-42

Электронная почта: org@eplast1.ru

Адрес: 198099, г. Санкт-Петербург, ул. Калинина, дом 2, корпус 4, литера А.