

TOSHIBA CMOS Linear Integrated Circuit Silicon Monolithic

TCK401G, TCK402G

External FET Driver IC

The TCK401G and TCK402G are 28 V high input voltage External FET driver IC. It has wide input voltage operation. And this features a slew rate control driver with small package WCSP6E (0.8 mm x 1.2 mm, t: 0.55 mm). Also it can block reverse current if switch turned off by using external series FET. Thus this is suitable for power management selector such as Battery Charge application.

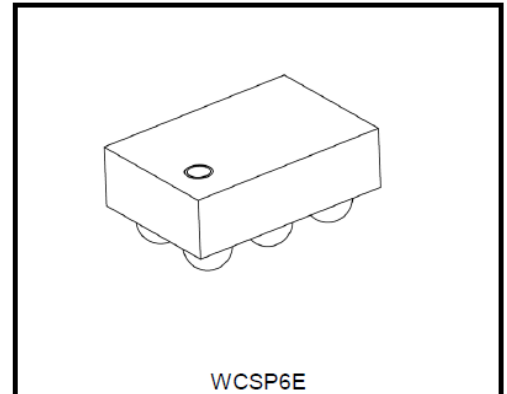

Weight: 1 mg(typ.)

Feature

- High maximum input voltage: $V_{IN\ max} = 40\ V$
- Wide input voltage operation: $V_{IN} = 2.7\ to\ 28\ V$
- Auto output discharge terminal
- Charge pump circuit
- Inrush current reducing circuit.
- Over Voltage lock out (Over 28 V)
- Under Voltage lock out (Under 2.7 V)
- Reverse Current Protection by External Back to Back MOSFET

Top marking (Top view)

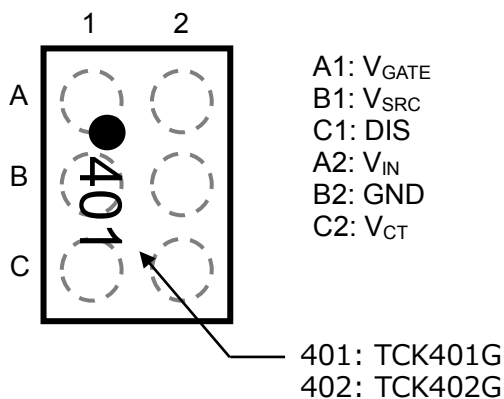

Start of commercial production
2017-10

• Absolute Maximum Ratings (Ta = 25°C)

Characteristics	Symbol	Rating	Unit
Input voltage	V _{IN}	-0.3 to 40	V
Control voltage	V _{CT}	-0.3 to 6	V
Output GATE voltage	V _{GATE}	-0.3 to V _{IN_opr} + V _{GS}	V
SRC voltage	V _{SRC}	-0.3 to V _{GATE}	V
DIS voltage	V _{DIS}	-0.3 to 40	V
Power dissipation	P _D	800 (Note 1)	mW
Operating temperature range	T _{opr}	-40 to 85	°C
Junction temperature	T _j	150	°C
Storage temperature	T _{stg}	-55 to 150	°C

Note: Using continuously under heavy loads (e.g. the application of high temperature/current/voltage and the significant change in temperature, etc.) may cause this product to decrease in the reliability significantly even if the operating conditions (i.e. operating temperature/current/voltage, etc.) are within the absolute maximum ratings. Please design the appropriate reliability upon reviewing the Toshiba Semiconductor Reliability Handbook ("Handling Precautions"/"Derating Concept and Methods") and individual reliability data (i.e. reliability test report and estimated failure rate, etc).

Note1: Rating at mounting on a board: FR4 board. (40 mm × 40 mm × 1.6 mm, Cu 4 layer)

• Recommended Operating Conditions

Characteristics	Symbol	Min.	Typ.	Max.	Unit
Input operation voltage	V _{IN_opr}	2.7	5.0	28	V
Capacitance	C _{IN}	0.1	1	—	μF
	C _{GATE}	—	2000	—	pF
CONTROL High-level input voltage	V _{IH}	1.6	—	—	V
CONTROL Low-level input voltage	V _{IL}	—	—	0.4	V

- Pin Assignment (Top view)

- WCSP6E

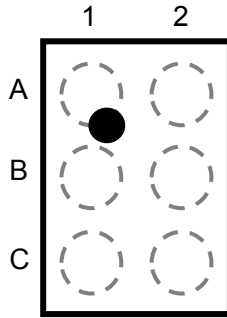

Pin #	Name	Pin #	Name
A1	V _{GATE}	A2	V _{IN}
B1	V _{SRC}	B2	GND
C1	DIS	C2	V _{CT}

- Product list

Part number	VCT function	VCT resistance
TCK401G	Active High	Pull down
TCK402G	Active Low	Pull down

- Block Diagram

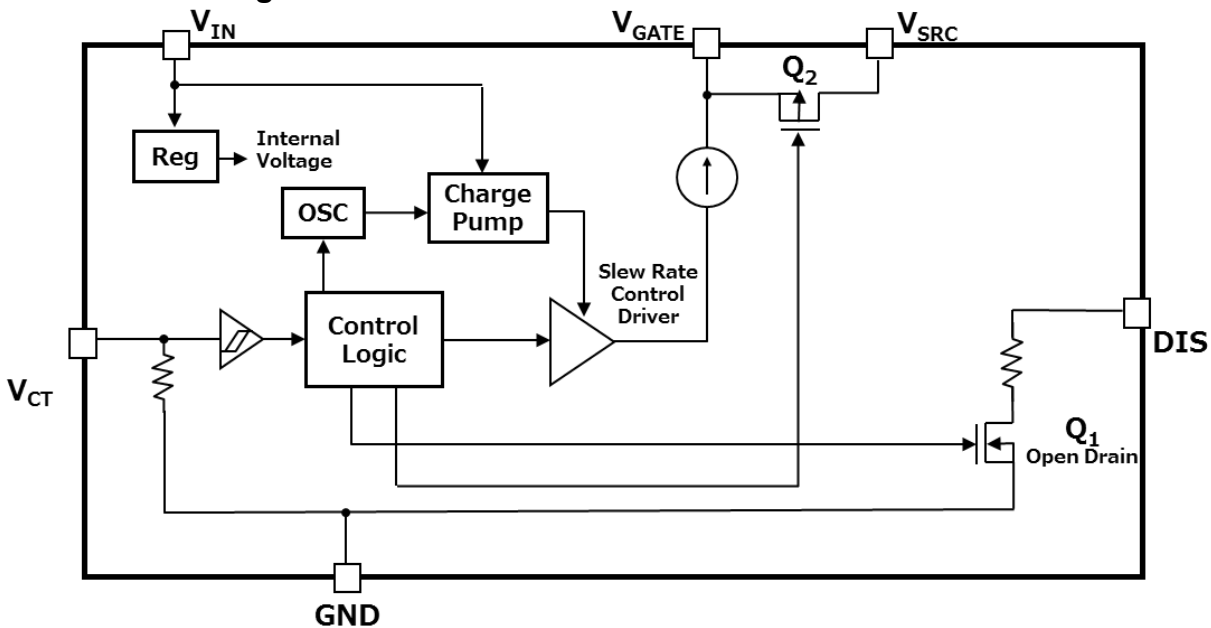

TCK401G PIN Description

PIN	Name	Description
A1	V _{GATE}	Gate-Driver Output.
A2	V _{IN}	Supply voltage input.
B1	V _{SRC}	Recommend connecting V _{SRC} terminal to the common source connection of the external MOSFETs.
B2	GND	Ground
C1	DIS	Output Discharge terminal.
C2	V _{CT}	Mode control input terminal. When V _{CT} =High turn the external MOSFETs on, V _{CT} =Low, turn the external MOSFETs off.

- **TCK402G PIN Description**

PIN	Name	Description
A1	V _{GATE}	Gate-Driver Output.
A2	V _{IN}	Supply voltage input.
B1	V _{SRC}	Recommend connecting V _{SRC} terminal to the common source connection of the external MOSFETs.
B2	GND	Ground
C1	DIS	Output Discharge terminal.
C2	V _{CT}	Mode control input terminal. When V _{CT} =Low turn the external MOSFETs on, V _{CT} =High, turn the external MOSFETs off.

- **TCK401G Operation Status Table**

2.7V ≤ V_{IN} ≤ 28 V (Ta = -40 to 85°C)

V _{CT}	V _{GATE}	Discharge Q1	comment
High	ON (V _{IN} + V _{GS})	OFF	Driver ON mode
Open	OFF	ON	Driver OFF mode
Low			

- **TCK402G Operation Status Table**

2.7V ≤ V_{IN} ≤ 28 V (Ta = -40 to 85°C)

V _{CT}	V _{GATE}	Discharge Q1	comment
Low	ON (V _{IN} + V _{GS})	OFF	Driver ON mode
Open			
High	OFF	ON	Driver OFF mode

DC Characteristics (Ta = -40 to 85°C)

Characteristics	Symbol	Test Condition	Ta = 25°C			Ta = -40 to 85°C (Note 2)		Unit	
			Min.	Typ.	Max.	Min.	Max.		
Input quiescent current (ON state)	IQ(ON)	TCK401G	VCT: High, VIN = 5.0 V	—	121	—	—	222	μA
			VCT: High, VIN = 9.0 V	—	144	—	—	283	μA
			VCT: High, VIN = 12 V	—	159	—	—	294	μA
			VCT: High, VIN = 20 V	—	198	—	—	376	μA
		TCK402G	VCT: Low, VIN = 5.0 V	—	121	—	—	222	μA
			VCT: Low, VIN = 9.0 V	—	144	—	—	283	μA
			VCT: Low, VIN = 12 V	—	159	—	—	294	μA
			VCT: Low, VIN = 20 V	—	198	—	—	376	μA
Standby current (OFF state)	IQ(OFF)	TCK401G	VCT: Low, VIN = 5.0 V	—	3.0	—	—	4.8	μA
			VCT: Low, VIN = 9.0 V	—	5.9	—	—	8.2	μA
			VCT: Low, VIN = 12 V	—	8.0	—	—	11.2	μA
			VCT: Low, VIN = 20 V	—	13.8	—	—	19.2	μA
		TCK402G	VCT: High, VIN = 5.0 V	—	3.0	—	—	4.8	μA
			VCT: High, VIN = 9.0 V	—	5.9	—	—	8.2	μA
			VCT: High, VIN = 12 V	—	8.0	—	—	11.2	μA
			VCT: High, VIN = 20 V	—	13.8	—	—	19.2	μA
GATE Drive voltage(VGATE-VIN)	VGS	VIN = 3 V	—	4.0	—	2.8	5.1	V	
		VIN = 5 V	—	6.5	—	5.1	7.9	V	
		VIN = 9.0 V	—	6.5	—	5.1	7.9	V	
		12 V ≤ VIN ≤ 28 V	—	8.5	—	6.9	10.0	V	
Output current	IGATE(ON)	VIN = 5 V	—	38	—	—	—	μA	
DIS resistance	RDIS	—	—	21	—	—	—	kΩ	
Control pull down resistance	RCT	VCT= 5 V	—	600	—	—	—	kΩ	

Note 2: This parameter is warranted by design.

• **AC Characteristics (Ta = 25°C, VIN=5V, CGATE=2000pF)**

Characteristics	Symbol	Test Condition (Figure 1,2)	Min.	Typ.	Max.	Unit
VGATE ON time	tON	Initial startup time of VGATE (Note 3) voltage from 0V to VIN +1V	—	0.58	0.8	ms
VGATE OFF time	tOFF	VGATE =0.5V	—	16.6	—	μs
VGATE rise time	tr	VGATE rising from VIN +1V to VIN +3V	—	0.2	—	ms
VGATE fall time	tf	VGATE falling from VIN +3V to VIN +1V	—	1.5	—	μs

• **AC Characteristics (Ta = 25°C, VIN=9V, CGATE=2000pF)**

Characteristics	Symbol	Test Condition (Figure 1,2)	Min.	Typ.	Max.	Unit
VGATE ON time	tON	Initial startup time of VGATE (Note 3) voltage from 0V to VIN +1V	—	0.78	1.0	ms
VGATE OFF time	tOFF	VGATE=0.5V	—	19.7	—	μs
VGATE rise time	tr	VGATE rising from VIN +1V to VIN +4V	—	0.35	—	ms
VGATE fall time	tf	VGATE falling from VIN +4V to VIN +1V	—	1.6	—	μs

• **AC Characteristics (Ta = 25°C, VIN=12V, CGATE=2000pF)**

Characteristics	Symbol	Test Condition (Figure 1,2)	Min.	Typ.	Max.	Unit
VGATE ON time	tON	Initial startup time of VGATE (Note 3) voltage from 0V to VIN +1V	—	0.92	1.2	ms
VGATE OFF time	tOFF	VGATE=0.5V	—	21.3	—	μs
VGATE rise time	tr	VGATE rising from VIN +1V to VIN +5V	—	0.6	—	ms
VGATE fall time	tf	VGATE falling from VIN +5V to VIN +1V	—	1.7	—	μs

Note 3: This parameter is warranted by design.

Timing chart

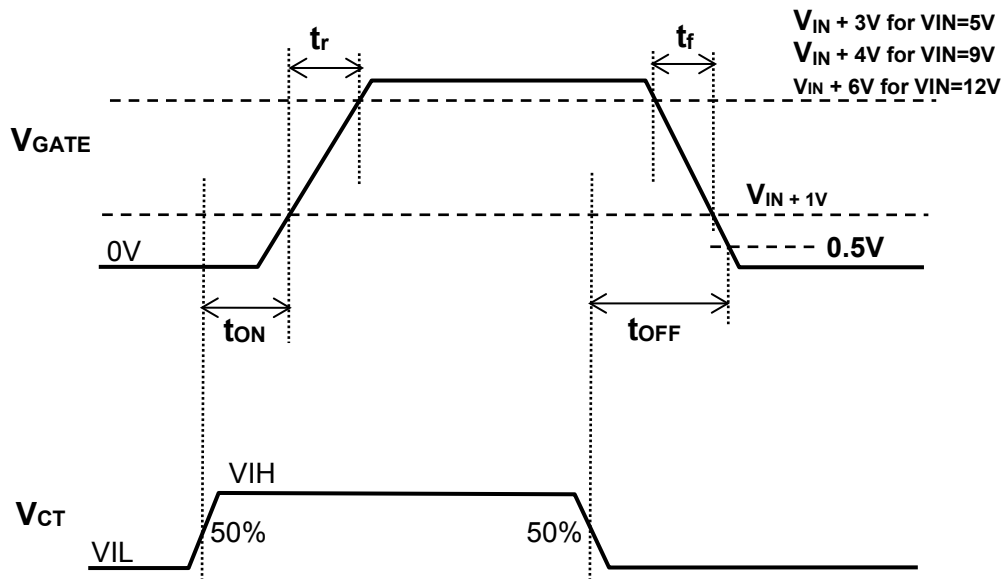

Fig.1 Active High (TCK401G)

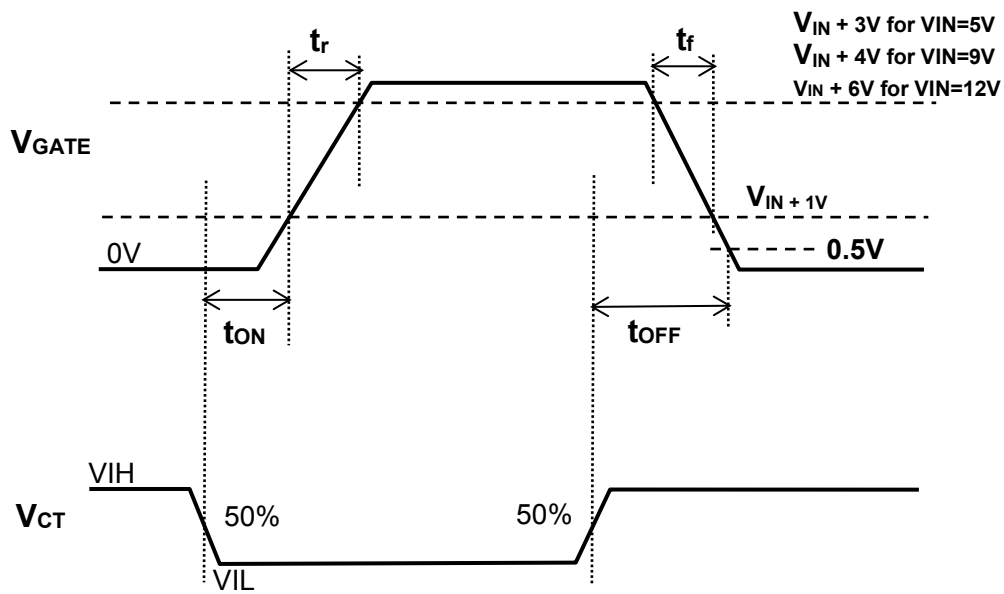
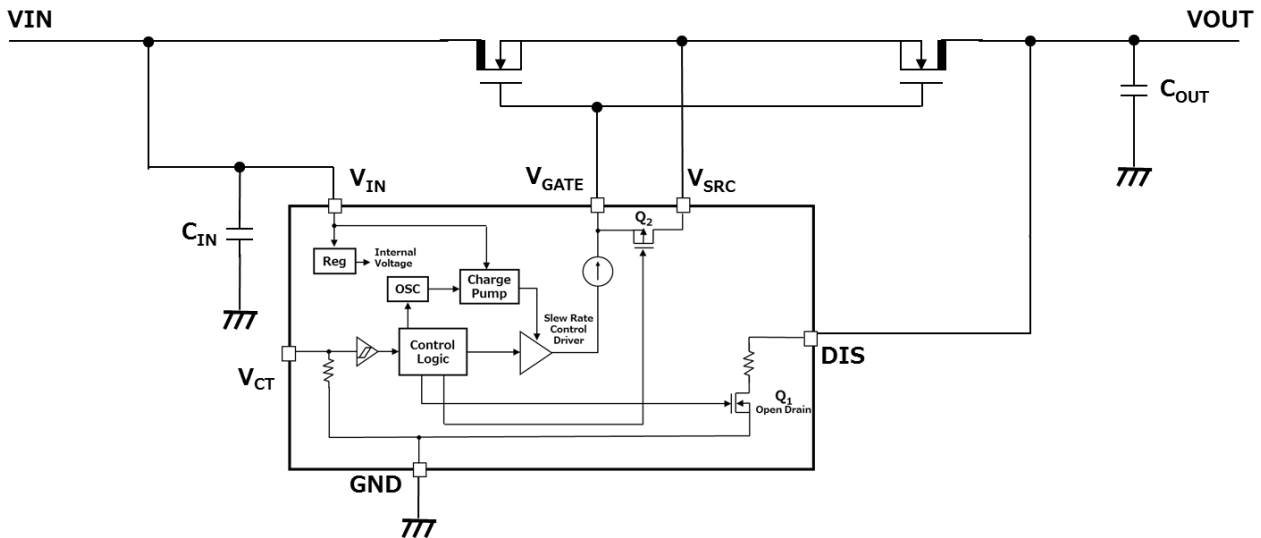

Fig.2 Active Low (TCK402G)

- Application Note
 - Application circuit example



1) Input and Output capacitor

An input capacitor (C_{IN}) and an output capacitor (C_{OUT}) is recommended for the stable operation of TCK401G and TCK402G. And it is effective to reduce voltage overshoot or undershoot due to sharp changes in output current and also for improved stability of the power supply. When used, place C_{IN} and C_{OUT} more than $1.0\mu F$ as close to V_{IN} pin to improve stability of the power supply.

2) V_{CT} pin

V_{CT} pin for TCK401G and TCK402G is operated by the control voltage and Schmitt trigger. V_{CT} pin has a tolerant function such that it can be used even if the control voltage is higher than the input voltage.

3) SRC Pin

For Dual MOSFET Driver, V_{SRC} work for short between V_{GATE} and MOSFET source when Driver IC Turn off. If there are enough margins of V_{GS} of MOSFET, V_{SRC} terminal Open state is no problem.

For Single MOSFET Driver, if there are enough margins of V_{GS} of MOSFET, V_{SRC} pin Open state is no problem. If there are not enough margins, we recommend connecting V_{SRC} and V_{OUT} . If connect V_{SRC} and V_{OUT} , t_{OFF} time become longer because of C_{OUT} . Therefore, please consider enough margins for MOSFET selection.

4) DIS Pin

If need Discharge function when Driver IC Turn off, please connect DIS Pin to V_{OUT} . If no need, DIS Pin Open state is no problem.

5) Over Voltage Protection off time (t_{OVP})

Over Voltage (V_{IN} is over $V_{IN_opr\ max}$) Protection off time (t_{OVP}) is similar V_{GATE} OFF time (t_{OFF}).

Timing chart

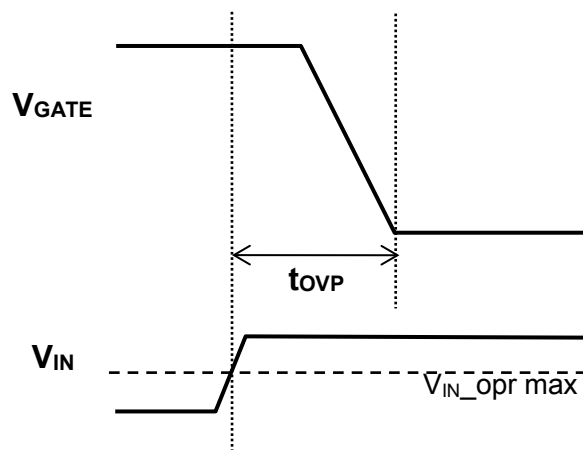
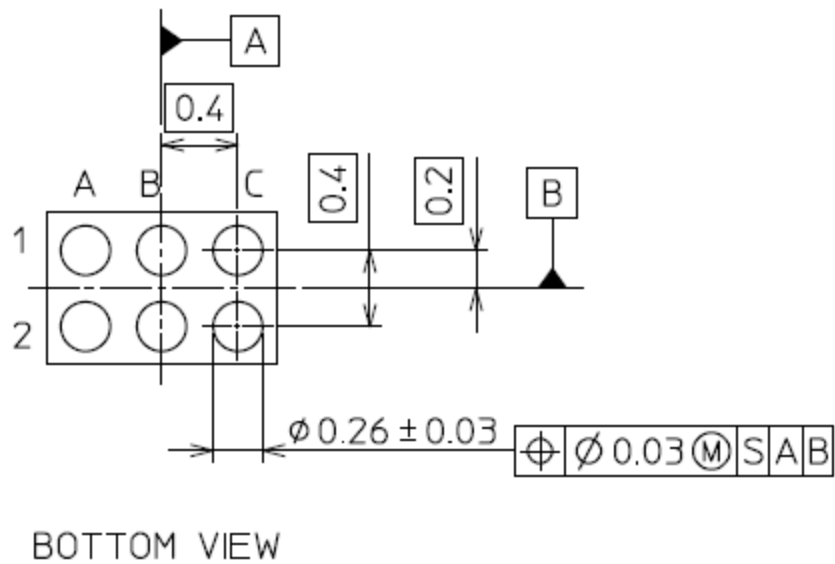
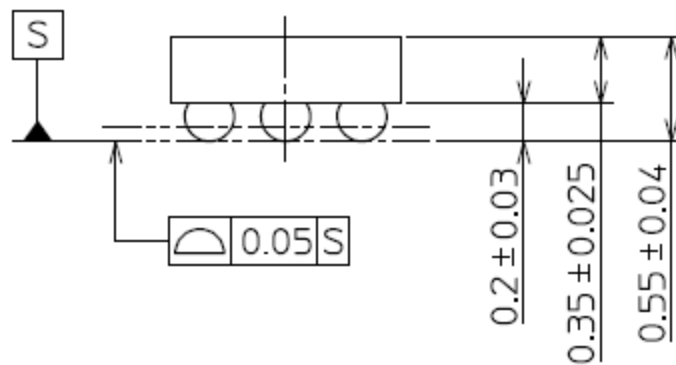
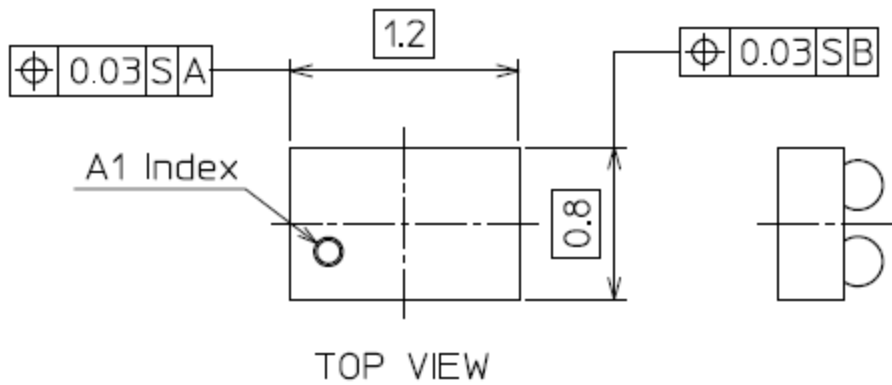

Fig.3 t_{OVP}

- Package dimension

Unit: mm



Weight: 1 mg (typ.)

Land pattern dimensions (for reference only)

Unit: mm

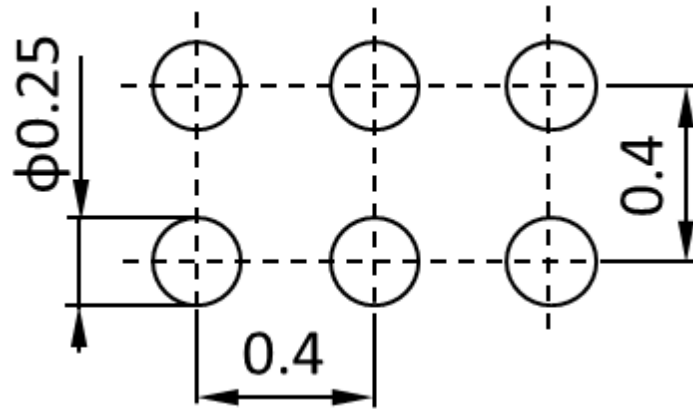

RESTRICTIONS ON PRODUCT USE

Toshiba Corporation and its subsidiaries and affiliates are collectively referred to as "TOSHIBA". Hardware, software and systems described in this document are collectively referred to as "Product".

- TOSHIBA reserves the right to make changes to the information in this document and related Product without notice.
- This document and any information herein may not be reproduced without prior written permission from TOSHIBA. Even with TOSHIBA's written permission, reproduction is permissible only if reproduction is without alteration/omission.
- Though TOSHIBA works continually to improve Product's quality and reliability, Product can malfunction or fail. Customers are responsible for complying with safety standards and for providing adequate designs and safeguards for their hardware, software and systems which minimize risk and avoid situations in which a malfunction or failure of Product could cause loss of human life, bodily injury or damage to property, including data loss or corruption. Before creating and producing designs and using, customers must also refer to and comply with (a) the latest versions of all relevant TOSHIBA information, including without limitation, this document, the specifications, the data sheets and application notes for Product and the precautions and conditions set forth in the "TOSHIBA Semiconductor Reliability Handbook" and (b) the instructions for the application that Product will be used with or for. Customers are solely responsible for all aspects of their own product design or applications, including but not limited to (a) determining the appropriateness of the use of this Product in such design or applications; (b) evaluating and determining the applicability of any information contained in this document, or in charts, diagrams, programs, algorithms, sample application circuits, or any other referenced documents; and (c) validating all operating parameters for such designs and applications. **TOSHIBA ASSUMES NO LIABILITY FOR CUSTOMERS' PRODUCT DESIGN OR APPLICATIONS.**
- Product is intended for use in general electronics applications (e.g., computers, personal equipment, office equipment, measuring equipment, industrial robots and home electronics appliances) or for specific applications as expressly stated in this document. Product is neither intended nor warranted for use in equipment or systems that require extraordinarily high levels of quality and/or reliability and/or a malfunction or failure of which may cause loss of human life, bodily injury, serious property damage or serious public impact ("Unintended Use"). Unintended Use includes, without limitation, equipment used in nuclear facilities, equipment used in the aerospace industry, medical equipment, equipment used for automobiles, trains, ships and other transportation, traffic signaling equipment, equipment used to control combustions or explosions, safety devices, elevators and escalators, devices related to electric power, and equipment used in finance-related fields. Do not use Product for Unintended Use unless specifically permitted in this document.
- Do not disassemble, analyze, reverse-engineer, alter, modify, translate or copy Product, whether in whole or in part.
- Product shall not be used for or incorporated into any products or systems whose manufacture, use, or sale is prohibited under any applicable laws or regulations.
- The information contained herein is presented only as guidance for Product use. No responsibility is assumed by TOSHIBA for any infringement of patents or any other intellectual property rights of third parties that may result from the use of Product. No license to any intellectual property right is granted by this document, whether express or implied, by estoppel or otherwise.
- **ABSENT A WRITTEN SIGNED AGREEMENT, EXCEPT AS PROVIDED IN THE RELEVANT TERMS AND CONDITIONS OF SALE FOR PRODUCT, AND TO THE MAXIMUM EXTENT ALLOWABLE BY LAW, TOSHIBA (1) ASSUMES NO LIABILITY WHATSOEVER, INCLUDING WITHOUT LIMITATION, INDIRECT, CONSEQUENTIAL, SPECIAL, OR INCIDENTAL DAMAGES OR LOSS, INCLUDING WITHOUT LIMITATION, LOSS OF PROFITS, LOSS OF OPPORTUNITIES, BUSINESS INTERRUPTION AND LOSS OF DATA, AND (2) DISCLAIMS ANY AND ALL EXPRESS OR IMPLIED WARRANTIES AND CONDITIONS RELATED TO SALE, USE OF PRODUCT, OR INFORMATION, INCLUDING WARRANTIES OR CONDITIONS OF MERCHANTABILITY, FITNESS FOR A PARTICULAR PURPOSE, ACCURACY OF INFORMATION, OR NONINFRINGEMENT.**
- Do not use or otherwise make available Product or related software or technology for any military purposes, including without limitation, for the design, development, use, stockpiling or manufacturing of nuclear, chemical, or biological weapons or missile technology products (mass destruction weapons). Product and related software and technology may be controlled under the Japanese Foreign Exchange and Foreign Trade Law and the U.S. Export Administration Regulations. Export and re-export of Product or related software or technology are strictly prohibited except in compliance with all applicable export laws and regulations.
- Please contact your TOSHIBA sales representative for details as to environmental matters such as the RoHS compatibility of Product. Please use Product in compliance with all applicable laws and regulations that regulate the inclusion or use of controlled substances, including without limitation, the EU RoHS Directive. TOSHIBA assumes no liability for damages or losses occurring as a result of noncompliance with applicable laws and regulations.

Mouser Electronics

Authorized Distributor

Click to View Pricing, Inventory, Delivery & Lifecycle Information:

[Toshiba:](#)

[TCK401G,LF](#)



Компания «ЭлектроПласт» предлагает заключение долгосрочных отношений при поставках импортных электронных компонентов на взаимовыгодных условиях!

Наши преимущества:

- Оперативные поставки широкого спектра электронных компонентов отечественного и импортного производства напрямую от производителей и с крупнейших мировых складов;
- Поставка более 17-ти миллионов наименований электронных компонентов;
- Поставка сложных, дефицитных, либо снятых с производства позиций;
- Оперативные сроки поставки под заказ (от 5 рабочих дней);
- Экспресс доставка в любую точку России;
- Техническая поддержка проекта, помощь в подборе аналогов, поставка прототипов;
- Система менеджмента качества сертифицирована по Международному стандарту ISO 9001;
- Лицензия ФСБ на осуществление работ с использованием сведений, составляющих государственную тайну;
- Поставка специализированных компонентов (Xilinx, Altera, Analog Devices, Intersil, Interpoint, Microsemi, Aeroflex, Peregrine, Syfer, Eurofarad, Texas Instrument, Miteq, Cobham, E2V, MA-COM, Hittite, Mini-Circuits, General Dynamics и др.);

Помимо этого, одним из направлений компании «ЭлектроПласт» является направление «Источники питания». Мы предлагаем Вам помощь Конструкторского отдела:

- Подбор оптимального решения, техническое обоснование при выборе компонента;
- Подбор аналогов;
- Консультации по применению компонента;
- Поставка образцов и прототипов;
- Техническая поддержка проекта;
- Защита от снятия компонента с производства.



Как с нами связаться

Телефон: 8 (812) 309 58 32 (многоканальный)

Факс: 8 (812) 320-02-42

Электронная почта: org@eplast1.ru

Адрес: 198099, г. Санкт-Петербург, ул. Калинина, дом 2, корпус 4, литера А.